

INTERNATIONAL COUNCIL FOR BUILDING RESEARCH STUDIES AND DOCUMENTATION

WORKING COMMISSION W18 - TIMBER STRUCTURES

CIB - W18

MEETING SIXTEEN

LILLEHAMMER

NORWAY

MAY/JUNE 1983

INTERNATIONAL COUNCIL FOR BUILDING RESEARCH STUDIES AND DOCUMENTATION
WORKING COMMISSION W18 - TIMBER STRUCTURES

PLANAR SHEAR CAPACITY OF PLYWOOD
IN BENDING

by

C K A Stieda

Council of Forest Industries of B.C.
Canada

LILLEHAMMER

NORWAY

MAY/JUNE 1983

INTERNATIONAL COUNCIL FOR BUILDING RESEARCH STUDIES AND DOCUMENTATION
WORKING COMMISSION W18 - TIMBER STRUCTURES

GRADING ERRORS IN PRACTICE

by

B Thunell

Royal Institute of Technology
Sweden

LILLEHAMMER

NORWAY

MAY/JUNE 1983

INTERNATIONAL COUNCIL FOR BUILDING RESEARCH STUDIES AND DOCUMENTATION

WORKING COMMISSION W18 - TIMBER STRUCTURES

ON THE EFFECT OF MEASUREMENTS ERRORS
WHEN GRADING STRUCTURAL TIMBER

by

L Nordberg and B Thunell

Royal Institute of Technology
Sweden

LILLEHAMMER

NORWAY

MAY/JUNE 1983

INTERNATIONAL COUNCIL FOR BUILDING RESEARCH STUDIES AND DOCUMENTATION

WORKING COMMISSION W18 - TIMBER STRUCTURES

SIZE FACTORS FOR
TIMBER BENDING AND TENSION STRESSES

by

A R Fewell

Building Research Establishment
Princes Risborough Laboratory
United Kingdom

MEETING SIXTEEN

LILLEHAMMER

NORWAY

MAY/JUNE 1983

INTERNATIONAL COUNCIL FOR BUILDING RESEARCH STUDIES AND DOCUMENTATION
WORKING COMMISSION W18 - TIMBER STRUCTURES

STRENGTH CLASSES
FOR INTERNATIONAL CODES

by

A R Fewell and J G Sunley

PRL / TRADA

United Kingdom

LILLEHAMMER

NORWAY

MAY/JUNE 1983

INTERNATIONAL COUNCIL FOR BUILDING RESEARCH STUDIES AND DOCUMENTATION
WORKING COMMISSION W18 - TIMBER STRUCTURES

LOAD-CARRYING
CAPACITY OF DOWELS

by

E Gehri

Applied Statics and Steel Structures
Swiss Federal Institute of Technology
Switzerland

LILLEHAMMER

NORWAY

MAY/JUNE 1983

INTERNATIONAL COUNCIL FOR BUILDING RESEARCH STUDIES AND DOCUMENTATION
WORKING COMMISSION W18 - TIMBER STRUCTURES

BOLTED TIMBER JOINTS:
A LITERATURE SURVEY

by

N Harding

Building Research Association of New Zealand
New Zealand

LILLEHAMMER

NORWAY

MAY/JUNE 1983

INTERNATIONAL COUNCIL FOR BUILDING RESEARCH STUDIES AND DOCUMENTATION

WORKING COMMISSION W18 - TIMBER STRUCTURES

BOLTED TIMBER JOINTS
PRACTICAL ASPECTS OF CONSTRUCTION AND DESIGN

A SURVEY

by

N Harding

Building Research Association of New Zealand
New Zealand

LILLEHAMMER

NORWAY

MAY/JUNE 1983

INTERNATIONAL COUNCIL FOR BUILDING RESEARCH STUDIES AND DOCUMENTATION
WORKING COMMISSION W18 - TIMBER STRUCTURES

BOLTED TIMBER JOINTS
DRAFT EXPERIMENTAL WORK PLAN

Building Research Association of New Zealand
New Zealand

LILLEHAMMER
NORWAY
MAY/JUNE 1983

INTERNATIONAL COUNCIL FOR BUILDING RESEARCH STUDIES AND DOCUMENTATION
WORKING COMMISSION W18 - TIMBER STRUCTURES

EFFECT OF TEST PIECE SIZE
ON PANEL BENDING PROPERTIES

by

P W Post

American Plywood Association
USA

LILLEHAMMER

NORWAY

MAY/JUNE 1983

INTERNATIONAL COUNCIL FOR BUILDING RESEARCH STUDIES AND DOCUMENTATION
WORKING COMMISSION W18 - TIMBER STRUCTURES

FULL-SCALE TESTS ON TIMBER FINK TRUSSES
MADE FROM IRISH GROWN SITKA SPRUCE

by

V Picardo

Forest Products Department
Institute for Industrial Research and Standards
Ireland

LILLEHAMMER

NORWAY

MAY/JUNE 1983

INTERNATIONAL COUNCIL FOR BUILDING RESEARCH STUDIES AND DOCUMENTATION
WORKING COMMISSION W18 - TIMBER STRUCTURES

DETERMINATION OF BRACING STRUCTURES
FOR COMPRESSION MEMBERS AND BEAMS

by

H Brüninghoff
Federal Republic of Germany

LILLEHAMMER

NORWAY

MAY/JUNE 1983

INTERNATIONAL COUNCIL FOR BUILDING RESEARCH STUDIES AND DOCUMENTATION
WORKING COMMISSION W18 - TIMBER STRUCTURES

NOTES ON SAMPLING AND STRENGTH PREDICTION
OF STRESS GRADED STRUCTURAL TIMBER

by

P. Glos

Lehrstuhl Baukonstruktion und Holzbau
Technische Universität München
Federal Republic of Germany

LILLEHAMMER
NORWAY
MAY/JUNE 1983

INTERNATIONAL COUNCIL FOR BUILDING RESEARCH STUDIES AND DOCUMENTATION
WORKING COMMISSION W18 - TIMBER STRUCTURES

SAMPLING TO PREDICT BY TESTING THE CAPACITY
OF JOINTS, COMPONENTS AND STRUCTURES

by

B Norén

Swedish Forest Products Research Laboratory
Sweden

LILLEHAMMER

NORWAY

MAY/JUNE 1983

INTERNATIONAL COUNCIL FOR BUILDING RESEARCH STUDIES AND DOCUMENTATION
WORKING COMMISSION W18 - TIMBER STRUCTURES

DISCUSSION OF SAMPLING
AND
ANALYSIS PROCEDURES

by

P W Post

American Plywood Association
USA

LILLEHAMMER

NORWAY

MAY/JUNE 1983

NOTES AND PAPERS
OF THE RILEM-MEETING

LILLEHAMMER
NORWAY
MAY 1983

REPORT
AFRICAN, CARIBBEAN AND
LATIN-AMERICAN SUB-GROUP

by

R S Beckett
University of Zimbabwe
Zimbabwe

LILLEHAMMER
NORWAY
MAY/JUNE 1983

CONTENTS

- 1 List of Delegates
- 2 Chairman's Introduction
- 3 Co-Operation with Other Organisations
- 4 Trussed Rafter Sub-Groups
- 5 Plywood and Sampling Sub-Groups
- 6 Timber Frame Housing
- 7 Joints
- 8 Stresses for Solid Timber
- 9 Sheet Materials
- 10 Stress Grading
- 11 Trussed Rafters
- 12 CIB Structural Timber Design Code
- 13 Bracing
- 14 Timber Grouping
- 15 Sampling
- 16 Other Business
- 17 Next Meeting
- 18 Papers Presented at the Meeting
- 19 Current List of CIB-W18 Papers
- 20 Notes and Papers of the RILEM-Meeting
- 21 Report African, Caribbean and Latin-American Sub-Group

1. LIST OF DELEGATES

CANADA

G A Dring Dring Canada LTD, Boissevain
C K A Stieda COFI of BC, North Vancouver

DENMARK

A Egerup Technical University of Denmark, Lyngby
M Johansen Statens Byggeforskningsinstitut, Hørsholm
H J Larsen Statens Byggeforskningsinstitut, Hørsholm
H Riberholt Technical University of Denmark, Lyngby

FEDERAL REPUBLIC OF GERMANY

H Brüninghoff CEI-Bois, Femib, Glulam, Ulm
J Ehlbeck Universität Karlsruhe, Karlsruhe
A Epple FMPA, Stuttgart
P Glos Technische Universität München, München
G Steck Universität Karlsruhe, Karlsruhe

FINLAND

J Kangas Technical Research Centre of Finland, Espoo
T Kelkola Tampere
E K Leppavuori Technical Research Centre of Finland, Espoo
T Poutanen Tampere

IRELAND

V Picardo Inst. f. Ind. Research + Standards, Dublin

ISRAEL

U Korin Building Research Station, Haifa

NETHERLANDS

J Kuipers Delft University of Technology, Delft

NORWAY

E	Aasheim	Norsk Treteknisk Institutt, Oslo
P	Aune	University of Trondheim, Trondheim
O	Brynildsen	Strømmen
R	Lackner	Norsk Treteknisk Institutt, Oslo
P	H Leirtun	Norges Byggstandardiseringsråd, Oslo
K	Mørkved	Norsk Treteknisk Institutt, Oslo
T	Ø Ramstad	Norges Byggforskningsinstitutt, Oslo

SWEDEN

B	Edlund	Chalmers University of Technology, Göteborg
B	Källsner	Svenska Träforskningsinstitutet, Stockholm
B	Norén	Svenska Träforskningsinstitutet, Stockholm
B	Thunell	Royal Inst. of Techn., Wood Techn. + Processing, Stockholm

SWITZERLAND

U	A Meierhofer	EMPA, Dübendorf
---	--------------	-----------------

UNITED KINGDOM

H	J Burgess	TRADA, High Wycombe
I	D G Lee	Chipboard Promotion Association, High Wycombe
R	Marsh	Ove Arup and Partners, London
R	C Mitzner	American Plywood Association, London
J	G Sunley	TRADA, High Wycombe
J	Tory	Princes Risborough Laboratory, Princes Risborough

UNITED STATES OF AMERICA

W	A Baker	American Plywood Association, Tacoma
P	W Post	American Plywood Association, Tacoma

ZIMBABWE

R	Beckett	University of Zimbabwe, Harare
D	T Fawcett	Standards Ass. of Central Africa, Mutare

2. CHAIRMAN'S INTRODUCTION

MR. SUNLEY said the publication of the Structural Timber Design Code by CIB Headquarters marked the end of a stage of work and resulted in a document to provide a basis for further developments in the EEC and ISO. It was now necessary to schedule the production of any further annexes that were felt to be needed, and to invite proposals for future alteration of the Code provided these were submitted in Code format.

3. CO-OPERATION WITH OTHER ORGANISATIONS

ISO/TC 165: DR. LARSEN said ISO 6891 had appeared, giving general principles for the testing of mechanical fasteners. A test standard for timber in structural sizes was to be circulated for voting. Another for plywood in structural sizes had encountered disagreement on specimen size. The first working draft of a design code based on the CIB Code would be sent out in advance of a meeting on the 28-9 May 1984 in Corsica, which would also consider strength grouping, glulam production and testing and other topics.

RILEM: PROFESSOR KUIPERS said his meeting on the previous day had divided into three working groups, and the group proceedings were reported by their Chairmen as follows:

TESTING METHODS FOR NAILS AND STAPLES. MR. TORY said Annex B on nail testing would appear shortly in the RILEM journal 'Materials and Structures' for comment. Annex C on staples would be similar and would be circulated to the RILEM group for preparation as a Recommendation. A discussion stimulated by PROFESSOR EHLBECK and DR. LARSEN agreed on the need for RILEM conclusions to be reached in collaboration with and endorsed by the CIB. MR. SUNLEY said the RILEM document on the testing of timber structures could appear on the agenda for the next meeting, and those on the testing of nails and staples could be included in the Lillehammer proceedings for comment.

TESTING OF STRUCTURES. DR. GLOS reported that comments had been received on a paper by MR. TORY which had also been adapted for the British design code. It had been agreed that the work should concentrate on timber structures in the first place, later seeing what should be added to deal with reconstituted materials. The interpretation of test results was to be considered but this topic would not be included in the second draft, which would appear at the next RILEM meeting for reporting to the associated CIB meeting.

BOARD MATERIALS TESTING. MR. LEE said the group had considered papers by himself and MR. POST. It seemed possible that the testing methods could follow closely those established for structural plywood but it was desirable to maintain a relationship with small quality control specimens. The responsibility for developing a draft document had been apportioned between himself and the American Plywood Association. For the longer term the development of non-destructive testing was foreseen following the lead given by MR. MORKVEDT; the possible use of stress-wave methods could be considered, and attention would be given to impact and creep testing.

It was agreed that a report on the RILEM discussions would be included in the CIB proceedings.

CEI-Bois/FEMIB: MR. SUNLEY said there had been no contact with this group, who were not represented at the meeting. DR. BRÜNINGHOF said he understood the FEMIB Sous-Commission GLULAM were discussing the control rules for glulam in different countries.

IUFRO S5.02: PROFESSOR EDLUND reported that the proceedings of the meeting in Boras, Sweden, 13-18 May 1982 were now available. A meeting would be held in Madison during the Division 5 conference, 27 June-5 July 1983 and several CIB-W18 members would be attending.

AFRICAN, CARIBBEAN and LATIN-AMERICAN sub-group: MR. BECKETT said he was acting as joint coordinator with DR. de FREITAS for this new sub-group. A three-week UNIDO workshop in Melbourne had been attended by representatives from twenty countries and many papers considered on a variety of topics. The Pacific Area Standards Congress were being joined in a larger group including South and Central America, India, South-East Asia, China and Tonga. There was great interest in the use of local renewable resources in timber engineering for low-cost housing and industrial buildings. He wished to express formal thanks to CIB members for the research basis they provided and for visits by certain CIB-W18 individuals, and would supply a brief report for inclusion in the CIB proceedings.

IABSE: PROFESSOR EDLUND reported as a representative of the International Association for Bridge and Structural Engineering, which he said had some 3000 members and held a conference in September each year as well as other minor meetings. A congress was held every four years and the one in Vienna in 1980 had included some reports on timber. The next would be in Vancouver in early

September 1984. It would include a half-day session on developments in wood structures and those interested were invited to obtain more information from the secretary in Zurich.

EEC EUROCODES: DR. LARSEN said drafts for steel and concrete had been sent out as technical reports for comment and not as binding on member countries; another would be the combination of concrete and steel. A coordinating group had set out to harmonize the different codes and CIB-W18 had been invited to collaborate. PROFESSOR KUIPERS had attended the first meeting and he himself had attended the second. Work on a timber code would probably be started as soon as the one for steel and concrete combined had been sent out. MR. SUNLEY said a sub-group would be formed early in 1984 to draft a code for timber.

4. TRUSSED RAFTER SUB-GROUP

DR. EGERUP reported there had been a decline in the activities of the sub-group but development work was going on in the different countries. The work of the Nordic group had been exemplified by papers by MR. RIBERHOLT for the Karlsruhe meeting. Denmark was working on span tables and MR. KÄLLSNER of Sweden on mathematical models. It was difficult to relate the Nordic approach applying sophisticated models and the simple methods favoured in some Western European countries; a combination might be found practicable, but research might be needed.

MR. SUNLEY said an Annex on a simplified method of trussed rafter design was needed for the Code, and it was agreed that the Nordic group should draft one for the next meeting.

5. PLYWOOD AND SAMPLING SUB-GROUPS

DR. NORÉN said his plywood sub-group had been dealing with sampling but there was no further work to report since the Karlsruhe meeting and it was difficult to approach more precise recommendations than had been given in the past.

MR. SUNLEY said a sub-group on materials sampling, not limited to plywood, had been set up at the last meeting and DR. NORÉN thought the two groups should combine; he said he would write to members of his sub-group to suggest that they joined in the work of the new sub-group under DR. GLOS. He thought the work should perhaps extend to the determination of characteristic values.

DR. GLOS said there were four topics to consider:

- (1) the sampling of sheet materials including plywood as investigated by DR. NORÉN, DR. BOOTH and others,
- (2) sampling for joint tests,
- (3) sampling for prototype timber structures,
- (4) sampling of structural timber.

As there had been coverage of items (1) to (3), he had started with item (4), looking at the objective and the analysis required to achieve it while bearing in mind the needs of the next 10-15 years in view of the non-stationary timber supply. It appeared to him that random sampling was of limited value and that advantage should be taken of the available engineering knowledge of the material.

He had made contact with individuals but a working group had not been composed formally pending a consideration of who would be in a position to make substantial contributions.

DR. STIEDA said the Canadian large-scale sampling of structural timber should be of interest to the group. DR. LARSEN suggested there might be papers on safety topics for the next meeting, including load duration effects as a reason for a different treatment of timber in comparison with other materials.

MR. MEIERHOFER said there was a special CIB sub-group on structural safety and that a member should perhaps be invited to the CIB-W18 meetings. PROFESSOR KUIPERS added that there was a TNO joint committee on steel and concrete; he thought it would be valuable for timber interests to have contact with other materials.

MR. SUNLEY concluded that the work would be continued by a single group on sampling, with a membership to be determined, and said he hoped it would meet before the next main meeting.

6. TIMBER FRAME HOUSING

MR. SUNLEY said terms of reference for this sub-group had been agreed but he had not found someone to act as its chairman. The need for a sub-group was questioned because the design methods in the CIB Code were applicable to houses as well as other structures. Following a later suggestion to consider earthquake design for timber frame housing, it was agreed to retain timber frame housing as an agenda item.

7. JOINTS

Introducing MR. GEHRI's paper CIB-W18/16-7-1 'Load Carrying Capacity of Dowels', MR. SUNLEY said it indicated the values in the CIB Code were too high. DR. LARSEN said the equations in the original draft had been simplified but Gehri's work showed that a dowel without a head would have a substantially lower strength than a bolt. It was agreed to revert to the earlier system of formulae; this would be kept in mind for an amendment and in the meantime the modification would be noted in the Proceedings.

The following New Zealand papers by MR. HARDING were introduced by MR. BURGESS: CIB-W18/16-7-2 'Bolted Timber Joints: a Literature Survey', CIB-W18/16-7-3 'Bolted Timber Joints: Practical Aspects of Construction and Design', CIB-W18/16-7-4 'Bolted Timber Joints: Draft Experimental Work Plan'. The papers were welcomed as a contribution to the meeting and their practical approach was commended. The Secretary was asked to thank the contributors for the papers, which would be included in the Proceedings.

8. STRESSES FOR SOLID TIMBER

MR. TORY introduced the paper by MR. FEWELL, CIB-W18/16-6-1 'Size Factors for Timber Bending and Tension Stresses'. He said it was developed from the paper by Fewell and Curry which appeared as an Appendix, concluding with the choice of a certain formula for modifying characteristic stresses. This had been adopted for application to bending and tension stresses in the British code.

After discussion it was felt that a depth factor of this kind could not be included in the CIB code because of the definition of characteristic stress in the code and because the formula was linked to a particular grading system.

9. SHEET MATERIALS

MR. STIEDA presented his paper CIB-W18/16-4-1 'Planar Shear Capacity of Plywood in Bending' developing formulae for the convenient calculation of shear stresses and shear capacities where an equivalent modulus of elasticity for the full thickness is quoted. An alternative calculation was suggested by DR. LARSEN.

MR. POST introduced his paper CIB-W18/16-13-1 'Effect of Test Piece Size on Panel Bending Properties'. This demonstrated reasons why the strength and stiffness derived from large panel tests differed from the results of tests on small specimens.

A different relationship was found for different materials. The paper concluded that it was best to use a specimen size reflecting that used in structural applications.

10. STRESS GRADING

Two related papers were presented by DR. THUNELL: CIB-W18/16-5-1 'Grading Errors in Practice' and CIB-W18/16-5-2 'On the Effect of Measurement Errors when Grading Structural Timber' by L. Nordberg and B. Thunell. The papers showed that the tolerances permitted by grading may influence the risk level considerably. Timber producers would favour a liberal tolerance but it should be considered what degree of latitude was acceptable to structural engineers. DR. GLOS drew attention to a paper at the Boras IUFRO meeting that might assist the studies, and it was agreed that he and Dr. Thunell would prepare a paper on their application for the next CIB-W18 meeting.

11. TRUSSED RAFTERS

The paper CIB-W18/16-14-1 'Full-scale Tests on Timber Fink Trusses made from Irish-Grown Sitka Spruce' was introduced by the author MR. PICARDO. He said use of a standard frame analysis package for design had resulted in excessively large member sections, while the spans in the British code were thought too great. Following tests on fifty-eight trusses, permissible spans were worked out corresponding to a load factor of 2.5.

DR. EGERUP said the test data would be needed for others to make use of the work. MR. PICARDO said he would supply the results and could include them in another paper. A number of questions were raised including one by MR. POUTANEN who asked whether the assumption of moment-stiff or hinged joints gave the best correspondence between calculations and tests. MR. PICARDO replied that the half-fixity provision in the British code seemed satisfactory.

12. CIB STRUCTURAL TIMBER DESIGN CODE

MR. SUNLEY expressed the appreciation of CIB-W18 members to DR. LARSEN for the work he had put into the preparation of the newly-published Code. Considering what further Annexes were needed, he suggested that perhaps Annex 43 should be replaced by one advising how to obtain characteristic values; this was agreed.

It was pointed out that Annexes on simplified trussed rafter design and the design of nail plates were needed and DR. LARSEN said the Nordic areas could produce the two documents. He added that a Chapter 7.4 on bracing was needed and it was agreed at the suggestion of PROFESSOR EHLBECK that DR. BRÜNINGHOF would write this for the next meeting. DR. LARSEN agreed to produce an Annex giving definitions.

13. BRACING

DR. BRÜNINGHOF introduced his paper CIB-W18/16-15-1 'Determination of Bracing Structures for Compression Members and Beams'. Following a question by MR. RIBERHOLT on the meaning of the assumed initial curvature, MR. BURGESS said that calculations in the United Kingdom were based on an estimate of the residual out-of-balance. He added that tests at the Central London Polytechnic showed that once the braced members were all deflected in the same direction, the bracing forces were not reduced by the fact that some were initially deflected in the other direction.

Answering a question by MR. DRING, the author said that equations 11.1 to 11.4 could be used for combined bending and axial loading, but as a simplification the bending and compression effects could be worked out separately and added finally.

14. TIMBER GROUPING

Presenting his paper in collaboration with Mr. A.R. Fewell, CIB-W18/16-6-2 'Strength Classes for International Codes', MR. SUNLEY said the United Kingdom needed a system of strength classes because of a wide range of imports but had to locate the class boundaries to make the most economical use of the chief timbers. Its application made allowance where appropriate for questions involving joint design loads, durability and resistance to preservative treatment.

DR. LARSEN thought another paper should be prepared showing exactly what factors were applied in deriving design values from characteristic values and DR. NOREN said this would provide a starting point for assessing how a more widely applicable system might be devised.

It was concluded that such a paper should be provided for the next meeting, together with another to serve as a basis for Annex 44. MR. TORY added that information on design stress derivations in other countries would be valuable.

15. SAMPLING

DR. GLOS's paper CIB-W18/16-17-1 'Notes on Sampling and Strength Prediction of Stress Graded Structural Timber' and DR. NORE^N's paper CIB-W18/16-17-2 'Sampling to Predict by Testing the Capacity of Joints, Components and Structures' were introduced by their authors. Relating a diagram in the former report to truss testing, DR. NORE^N showed that approval testing of a small number of prototypes could not make adequate allowance for the variability of timber. He thought the aim should be to develop more truly representative models as a basis for calculations, using prototype testing for joints and to check the correctness of the models. A proposal for selecting wood for truss tests was given in the Appendix of his paper.

Following a discussion of the two papers DR. GLOS confirmed that his sampling group would make a proposal for Annex 41 for the next meeting and asked for data from other countries to yield information on the variability of timber from different locations at different times.

MR. POST introduced his paper CIB-W18/16-17-3 'Discussion of Sampling and Analysis Procedures', favouring the use of the weakest material for structural tests. He said it was difficult to pick out the lowest strength panel from a group of panels, and random procedures should then be used, but the worst material should be selected from each panel.

MR. LEE said non-random selection of the worst material was difficult in the case of particleboard and expressed surprise that non-destructive testing methods were not given greater prominence. MR. SUNLEY concluded that the ideas expressed by MR. POST would be received by the sampling group in connection with the preparation of Annexes 41 and 44.

16. OTHER BUSINESS

In addition to the topics already noted for consideration at the next meeting, DR. LARSEN proposed an item on earthquake design for timber-frame housing.

MR. SUNLEY said he wished to relinquish his chairmanship of CIB-W18 after ten years of office. He hoped to hand over to a new chairman at the next meeting.

MR. SUNLEY expressed the thanks of all those attending for the excellent arrangements made for the meeting by MR. AASHEIM and the host country.

17. NEXT MEETING

The next meeting of CIB-W18 will take place in Zurich, Switzerland, on the 22nd-25th May 1984.

The Chairmen of sub-groups are invited to progress the proceedings of their sub-groups well in advance of the main meetings.

18. PAPERS PRESENTED AT THE MEETING

- CIB-W18/16-4-1 Planar Shear Capacity of Plywood in Bending
- C K A Stieda
- CIB-W18/16-5-1 Grading Errors in Practice - B Thunell
- CIB-W18/16-5-2 On the Effect of Measurement Errors when
Grading Structural Timber - L Nordberg
and B Thunell
- CIB-W18/16-6-1 Size Factors for Timber Bending and Tension
Stresses - A R Fewell
- CIB-W18/16-6-2 Strength Classes for International Codes -
A R Fewell and J G Sunley
- CIB-W18/16-7-1 Load-Carrying Capacity of Dowels -
E Gehri
- CIB-W18/16-7-2 Bolted Timber Joints: a Literature Survey -
N Harding
- CIB-W18/16-7-3 Bolted Timber Joints: Practical Aspects of
Construction and Design; a Survey
- N Harding
- CIB-W18/16-7-4 Bolted Timber Joints: Draft Experimental
Work Plan - Building Research Association
of New Zealand
- CIB-W18/16-13-1 Effect of Test Piece Size on Panel Bending
Properties - P W Post
- CIB-W18/16-14-1 Full-Scale Tests on Timber Fink Trusses
Made from Irish Grown Sitka Spruce -
V Picardo
- CIB-W18/16-15-1 Determination of Bracing Structures for Com-
pression Members and Beams - H Brüninghoff

- CIB-W18/16-17-1 Notes on Sampling and Strength Prediction
of Stress Graded Structural Timber -
P Glos
- CIB-W18/16-17-2 Sampling to Predict by Testing the Capacity
of Joints, Components and Structures -
B Norén
- CIB-W18/16-17-3 Discussion of Sampling and Analysis Proce-
dures - P W Post

INTERNATIONAL COUNCIL FOR BUILDING RESEARCH STUDIES AND DOCUMENTATION
WORKING COMMISSION W18 - TIMBER STRUCTURES

PLANAR SHEAR CAPACITY OF PLYWOOD
IN BENDING

by

C K A Stieda

Council of Forest Industries of B.C.
Canada

LILLEHAMMER

NORWAY

MAY/JUNE 1983

INTERNATIONAL COUNCIL FOR BUILDING RESEARCH STUDIES AND DOCUMENTATION
WORKING COMMISSION W18 - TIMBER STRUCTURES

PLANAR SHEAR CAPACITY OF PLYWOOD
IN BENDING

by

C K A Stieda

Council of Forest Industries of B.C.
Canada

LILLEHAMMER

NORWAY

MAY/JUNE 1983

INTERNATIONAL COUNCIL FOR BUILDING RESEARCH STUDIES AND DOCUMENTATION
WORKING COMMISSION W18 - TIMBER STRUCTURES

PLANAR SHEAR CAPACITY OF PLYWOOD
IN BENDING

by

C K A Stieda

Council of Forest Industries of B.C.
Canada

LILLEHAMMER

NORWAY

MAY/JUNE 1983

PLANAR SHEAR CAPACITY OF PLYWOOD IN BENDING

The magnitude of planar shear stresses in a narrow plywood panel subjected to bending due to lateral loads can be calculated using the same principles that are used to derive shear stresses in isotropic and homogeneous beams. Assume that the material is elastic and that plane sections remain plane during bending. Stresses due to bending then will be distributed linearly as shown in Fig. 1. Because the modulus of elasticity for adjacent plies differs, the stress distribution will be stepped as shown in Fig. 2.

Consider now the forces on an isolated element A B C D of length dx as shown in Fig. 3. The line B D of this element shall coincide with the neutral axis of the panel. Maximum bending stresses on faces A B and C D will differ by the amount df due to the change of bending moment dM over the distance dx . The integration of all differential stresses $df_x = f_2 - f_1$ over the height D C and the width b of the panel has to be equal to the total force along the neutral axis due to shear stresses v .

$$b \int_D^C df dy = v b dx$$

Using elementary bending theory, the magnitude of bending stresses is given by the stiffness EI of the section, the modulus of elasticity E_v of individual plies and the location y of the point for which the stress is calculated.

$$f = \frac{M y E_v}{(EI)}$$

The shear stress therefore becomes

$$v = \int_D^C \frac{dM y E_v}{dx (EI)} dy$$

Since $dM/dx = V$ and the stiffness EI is constant, the shear stress becomes

$$v = \frac{V}{(EI)} \int_D^C E_V y dy \quad (1)$$

The modulus of elasticity E_V is constant for a given veneer, but will vary from one ply to the next. The integration therefore can be replaced by a summation for the individual veneers (i), so that the shear stress becomes

$$v = \frac{V}{(EI)} \sum_i E_{Vi} t_i y_i \quad (2)$$

For a given planar shear stress the planar shear capacity therefore will be

$$V = \frac{v EI}{\sum_i E_{Vi} t_i y_i} \quad (3)$$

For a homogeneous, isotropic section E_V in Eq. 1 will be constant and the equation then reduces to the familiar

$$v = \frac{V}{Ib} \int_A b y dy$$

where the value of the integral often is given the designation Q . An analogous expression Q for plywood would be

$$Q = \frac{(\sum_i E_{Vi} t_i y_i) Ib}{(EI)}$$

which would allow shear stresses to be calculated by the familiar equation

$$v = \frac{VQ}{Ib}$$

This would require the separate tabulations of (EI) for bending calculations and of Q and I for shear calculations. It is more appropriate therefore to define a quantity (EQ)

$$EQ = b \sum_i E_{Vi} t_i y_i \quad (4)$$

and calculate planar shear stresses as

$$v = \frac{V(EQ)}{b(EI)} \quad (5)$$

This will require the tabulation of (EQ) only for shear calculations and would be a visual reminder that the shear stresses induced are affected by the magnitude of the modulus of elasticity of the various plies.

If planar shear capacities are to be calculated, this can be done readily as

$$V = \frac{v b (EI)}{(EQ)} \quad (6)$$

It is proposed that in future all planar shear calculations at COFI be done using Eq. 4, 5 and 6.

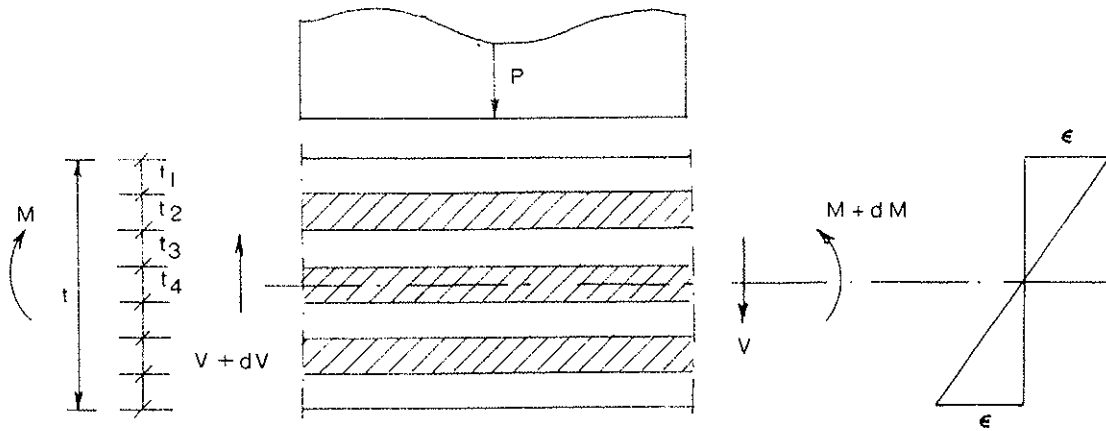

Fig. 1 Strain Distribution due to Bending

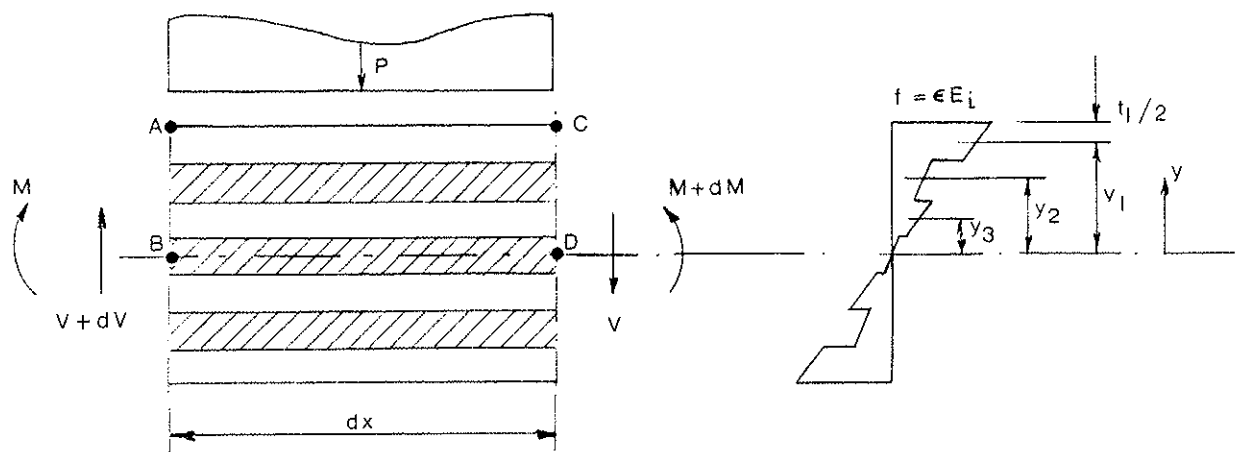

Fig. 2 Stress Distribution due to Bending

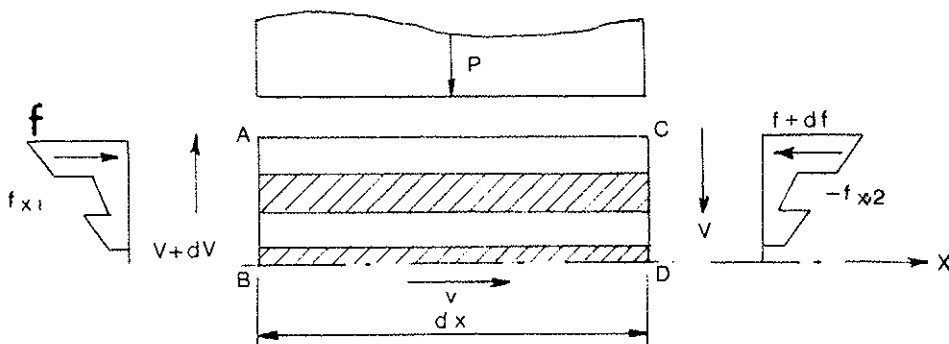

Fig. 3 Stresses on Free Body Element A B C D

INTERNATIONAL COUNCIL FOR BUILDING RESEARCH STUDIES AND DOCUMENTATION
WORKING COMMISSION W18 - TIMBER STRUCTURES

GRADING ERRORS IN PRACTICE

by

B Thunell

Royal Institute of Technology
Sweden

LILLEHAMMER

NORWAY

MAY/JUNE 1983

INTERNATIONAL COUNCIL FOR BUILDING RESEARCH STUDIES AND DOCUMENTATION
WORKING COMMISSION W18 - TIMBER STRUCTURES

GRADING ERRORS IN PRACTICE

by

B Thunell

Royal Institute of Technology
Sweden

LILLEHAMMER

NORWAY

MAY/JUNE 1983

INTERNATIONAL COUNCIL FOR BUILDING RESEARCH STUDIES AND DOCUMENTATION
WORKING COMMISSION W18 - TIMBER STRUCTURES

GRADING ERRORS IN PRACTICE

by

B Thunell

Royal Institute of Technology
Sweden

LILLEHAMMER

NORWAY

MAY/JUNE 1983

GRADING ERRORS IN PRACTICE

Bertil Thunell

ROYAL INSTITUTE OF TECHNOLOGY
Wood Technology and Processing
Stockholm, Sweden

Keywords:
Visual grading,
Characteristic strength
Tolerance in grading

Tolerances in Visual Grading and their Influence on the Strength of Timber of a certain Grade.

*

The strength properties of structural timber can be forecast and determined in a number of different ways on different premises, though two methods predominate.

Using one of the methods timber already *visually strength graded* is tested and the test material is related to a certain timber grade. A result is then obtained which is given in the form of a diagram showing the distribution of the different strength values. With this diagram as a basis and applying statistical methods, one may determine the so-called 5% percentile level with a certain confidence. Many views of the choice of statistical methods have been published and the main cause of this discussion is that the distribution curves are asymmetrical.

The method implies an in-grade testing and has been used where structural grade have already been established, The procedure is

Paper originally prepared for the Meeting of IUFRO Timber Engineering Group, April, 1982. Revised May, 1982.

reliable and applicable if the considered variable is determined with the constant accuracy, that is if the grading is done with the same margin of error every time.

Another way to obtain a basis for grading rules is to test timber sampled at random from *mill-run timber* and determine the characters of quality in connection with the strength testing, according to some method of criteria that one wishes to study then or that perhaps already has been decided upon.

One then obtains a correlation between the criterion of quality and the strength with its distribution and its correlation coefficient. Using this material the quality limits may then be determined for the desired strength levels in relation to the 5% percentile level. Because the distribution of the strength deviates from the normal distribution the same statistical complications arise using the in-grade method. This method has given the basis of several of the rules for structural timber in use today.

To make the statistical calculations valid, the quality variables have to be determined in practice with the same accuracy as when testing. There may often be a discrepancy between the measurement in connection with the testing and the visual judgement, when the grading is done in practice.

Using the in-grade method the quality is determined through the grading and the timber is normally sampled from saw timber handled in the ordinary way under conditions valid in practice and with the normal uncertainty attached to visual grading. Within the distribution that the figures from the strength test show, some of the uncertainty may be due to tolerances in the visual grading.

With timber that has not been visually stress graded before the test, the qualities determined in connection with the test and the defects

measured with great precision and the necessary time may be employed without being limited by the usual production demands. The grading in a sawmill or timber yard has to be done relatively quickly in order to meet the demands of economical production. This means that when the grading rules are used in practice, the conditions that were ruling when the correlations between strength and quality were determined, are no longer valid. The quality variable put in is bound to be more uncertain in practice than in testing.

A certain feeling for the uncertainty seems to have been allowed for when working out many of the rules applied for structural grades, as limitations for the deviations allowed at the grading have been introduced.

In the Swedish rules for structural timber that have long been in use, there also is a limit in respect of the deviations. According to the T-timber rules, when a timber parcel is re-examined the maximum allowed defects must not be exceeded by more than 10% irrespective of the number of pieces with too big defects.

In BS-4978 it is stated that not more than 5% of the pieces may exceed up to 10%. The North-American grading rules provided that 95% of the number of pieces must be within the grade. In the ECE-Standard from 1977 it is said that 90% of the pieces should be within the permissible limits and the remaining 10% must not exceed the limits by more than 15%.

In the proposed revision (July, 1981) of the ECE recommended standard for coniferous sawn timber, it is stated that re-inspection of a graded parcel reveals that not more than 3% of the pieces in the sample exceed the permissible limits by more than 30% of the parcel, the parcel is then considered as being on grade.

Three different principles may be discerned from these rules:

- 1 During regrading for control purposes the stated limits may be exceeded up to a given tolerance without the number of pieces with larger defects being limited.
- 2 A certain part of the parcel may have greater defects but no limit is set for these defects.
- 3 Both the relative number of pieces with greater defects than stipulated and how much the limits may be exceeded are maximized.

In the first case the Swedish T-timber rules may serve as an example. When these rules were first made, one started from the strength levels wanted and decided the permissible knot sizes from the test results and subtracted 10% from the knot sizes originally obtained. This means that no limits to the number of knots are needed to ensure the strength.

The North-American rules may serve as an example of the second case. It may seem bold not to have any limits for the size of deviations, if only what is specifically prescribed is taken into account. However, it is necessary to look at the North-American system as a whole, if one is to make a correct judgement. In this system a relatively intensive and continuous control of the grader's work is presupposed and the deviations that may occur have to be regarded as mere accidental errors and not as general tolerances. On the whole this system works satisfactorily. One must not take the conditions given for the deviation, though, without considering the other parts of the control system. It is above all since "in-grade" testing started that it has been possible to ensure the strength of the timber qualities declared.

The third case where the number of deviations as well as the size of deviation are maximized is to be found in the BS-4978 and the ECE-Standard. If the permissible deviations are kept down, one may perhaps overlook the risk of extremely low strength by the occurrence of bigger timber defects than those stipulated in the limit value. If the permissible deviations become considerable, supplementary "in-grade" testing has to be done with a grading reproducing the conditions from the practical conditions. Another way could be to consider the tolerances in the practical grading when making the statistical analysis.

If, for example, one supposes that 10% of the timber is allowed to deviate up to 15%, this increases the amount that could fall below the characteristic strength value considerably, if the grader has made full use of the allowance. Depending on the strength and knot size distribution for the pieces, this could possibly cause noticeable reduction in the characteristic strength.

Conclusions

- 1 In setting up grading rules for the visual grading of structural timber for practical use with corresponding characteristic values, the whole system in which the rules is supposed to work in the mills and yards has to be considered - i.e. responsibility, supervision, etc. as in the US and Canada.
- 2 Tolerances in the stipulated size limits for defects must not be used to stretch out the limits but to take care of occasional errors in a practical and economical way.
- 3 When calculating characteristic strength the uncertainty of the grading work in practice must be taken into consideration, if this has not already influenced the material from which the sampling is performed.

4. The maximum permissible tolerance must be internationally studied and recommended to avoid difficulties in the use of timber.

INTERNATIONAL COUNCIL FOR BUILDING RESEARCH STUDIES AND DOCUMENTATION

WORKING COMMISSION W18 - TIMBER STRUCTURES

ON THE EFFECT OF MEASUREMENTS ERRORS
WHEN GRADING STRUCTURAL TIMBER

by

L Nordberg and B Thune11

Royal Institute of Technology

Sweden

LILLEHAMMER

NORWAY

MAY/JUNE 1983

INTERNATIONAL COUNCIL FOR BUILDING RESEARCH STUDIES AND DOCUMENTATION

WORKING COMMISSION W18 - TIMBER STRUCTURES

ON THE EFFECT OF MEASUREMENTS ERRORS
WHEN GRADING STRUCTURAL TIMBER

by

L Nordberg and B Thunell

Royal Institute of Technology

Sweden

LILLEHAMMER

NORWAY

MAY/JUNE 1983

INTERNATIONAL COUNCIL FOR BUILDING RESEARCH STUDIES AND DOCUMENTATION

WORKING COMMISSION W18 - TIMBER STRUCTURES

ON THE EFFECT OF MEASUREMENTS ERRORS
WHEN GRADING STRUCTURAL TIMBER

by

L Nordberg and B Thunell

Royal Institute of Technology

Sweden

LILLEHAMMER

NORWAY

MAY/JUNE 1983

ON THE EFFECT OF MEASUREMENT ERRORS WHEN GRADING STRUCTURAL TIMBER

Lennart Nordberg and Bertil Thunell

ROYAL INSTITUTE OF TECHNOLOGY
Wood Technology and Processing
S-100 44 STOCKHOLM, Sweden

Keywords:

Structural timber, grading,
errors in grading, tolerances
in grading

CONTENTS

	Page
Abstract	
1. Introduction	1
2. Basic assumptions and formulas	2
3. The case of a systematic error	5
a) Normal distribution	5
b) Uniform distribution	7
c) Remarks	9
4. The case of a random error	9
5. Conclusions	11
References	11
Appendix	12

ON THE EFFECT OF MEASUREMENT ERRORS WHEN GRADING STRUCTURAL TIMBER

Lennart Nordberg and Bertil Thunell

ROYAL INSTITUTE OF TECHNOLOGY
Wood Technology and Processing
S-100 44 STOCKHOLM, Sweden

ABSTRACT

When grading timber for structural purposes one cannot measure the strength properties, e.g. Modules Of Rupture (MOR), directly for each piece in current operations. Instead one has to use some related Estimated Parameter (EP) such as the Knot Area Ratio (KAR).

Extensive tests have shown that there is an approximate linear relation between MOR and KAR for structural timber. Thus a quality criterion in strength can be transformed into one in EP. In doing so a certain misclassification risk is introduced due to the statistical nature (linear regression) of the relation between strength and EP.

When determining EP in practice a measurement error is introduced. The aim of this paper is to investigate the effect of this error on the above misclassification risk. The systematic — as well as random — case is treated.

1. INTRODUCTION

Grading of sawn timber for structural purposes is done in two principle ways, visually by a grader or mechanically by a machine. Knotiness must be considered first but the grading is also influenced by other quality factors. By making a quality definition you therefore have to use an estimable parameter, for example the knot area ratio, KAR, a machine modulus or any other property related to the strength properties. In the following text this parameter is called EP.

In the first case with grading visually, the grader has to observe the strength reducing defects in each piece and classify them according to given rules and sizes. In doing so he has to keep a certain rate for production reasons and cannot possibly pay much attention to each piece. As a consequence the result of this examination is impaired by a certain lack of exactness. The grading rules he has to work with are based on very extensive tests at which the defects in the timber have been measured carefully and very precisely and the strength properties have been determined by rupture tests.

From the test results the correlation between the quality — mainly the knotiness — and modulus of rupture (MOR) has been calculated with the corresponding standard deviation. In Section 2 we will specify how the upper knot size limit (permissible limit) can be determined from an intended minimum MOR-value through this relation between KAR and MOR.

As the strength properties can be more or less normally distributed, there have been discussions in the literature as to which statistical method should be used. Since a statistical material is not better than the sampling method used, and the sampling in this case cannot be done without influence from a lot of local factors, the following text is based on the assumption of a normal distribution.

By using the obtained regression equations, it is possible to establish the maximum sizes for the defects — knots — for the structural grades. With respect to the difficulties to judge the sizes exactly, it is necessary to permit certain deviations defined as tolerance limits. The measurement of the defects at the test is thus very accurate but in the sawmill and timber yard it has to be done by eye.

List of abbreviations and symbols

EP	- Estimable parameter
KAR	- Knot area ratio
MOR	- Modulus of rupture
ξ_0	- Permissible EP-limit
ξ	- "True" EP-value of a piece of timber
x	- Registered EP-value of a piece of timber
Δ	- Systematic error in EP (Section 3)
σ_δ	- Standard deviation of random error in EP (Section 4)
μ_ξ	- Average "true" EP in a package
σ_ξ	- Standard deviation of EP in a package
$f_\xi(t)$	- Probability density for "true" EP
y	- Strength (e.g. MOR) of a piece of timber
y_0	- Minimum strength limit.

In the second case -- grading by machine -- the machine is using one or other mechanical or physical property as a parameter. This parameter is related to an acceptable correlation to the strength properties which have been established by tests. Normally the machine has been used to classify the timber which then has been tested to determine ultimate load and standard deviation to enable the calculation of the 5% fractile limit. The machine can thus be calibrated and programmed to sort timber out with a desired stress level. The uncertainty in the operation of the machine in practice is incorporated in the final results.

This method is working well in practice on two provisions:

1. The machine must be properly maintained and trimmed so that the function will be the same as when the calculation was made.
2. The machine must be correctly programmed without any systematic error.

There are hence reasons to try to analyse both how a lack of exactness in the grading work will influence the accepted risk for rupture and what will happen with the risk if the maximum limits for the defects in a grade could be moved with regard to the formulation of the tolerance limits or a systematic error in the machine.

2. BASIC ASSUMPTIONS AND FORMULAS

Consider the following problem. In a timber yard or sawmill handling timber for structural purposes, one would like to grade the timber into two quality classes (acceptable vs. not acceptable) according to the desired strength properties.

More specifically, we will assume that a piece of timber is acceptable if its strength y is larger than a prescribed number y_0 and not acceptable otherwise. (In the sequel we will refer to this as the "ideal" quality criterion.)

However, strength cannot be measured directly in current operations so the grading has to be made by some related quantity which can be readily determined for each piece of timber. As mentioned in Section 1, such a quantity denoted EP, exists. For instance, earlier studies have shown that there is an approximate linear relationship between the modulus of rupture MOR, in

bending and the knot area ratio, KAR, of a piece of timber. We now make the following technical assumption.

Assumption 1

Consider a piece of timber chosen at random from the population of pieces having EP-value $\xi = t$, where t is a given number. Then the strength y of the chosen piece may be considered as an $N(a + bt, \sigma)$ -distributed random variable. The parameters $a > 0$, $b < 0$, and $\sigma > 0$ are assumed to be known.

Experience from earlier studies indicates that if y and ξ are MOR and KAR respectively then the following numerical values (measured in MPa) are reasonable: $a = 60$, $b = -50$ and $\sigma = 6$. These values will be used in the numerical examples presented ahead.

Now, the following procedure seems natural.

Grading procedure

Measure the EP-value ξ for each piece of timber. A piece is classified as acceptable if $\xi \leq \xi_0$ and not acceptable if $\xi > \xi_0$, where ξ_0 is a prescribed permissible limit for the intended stress grade.

In this paper we will assume that the permissible limit ξ_0 has been determined by the following relation.

$$P(y \leq y_0 \mid \xi = \xi_0) = 0.05 \quad , \quad (2.1)$$

i.e. the (conditional) probability is 5% that the strength properties of a piece of timber are not acceptable (by the "ideal" criterion) given that its EP-value attains the permissible limit.

The following relation between y_0 and ξ_0 is readily obtained from (2.1) and Assumption 1.

$$y_0 = a + b\xi_0 - 1.645\sigma \quad , \quad (2.2)$$

and thus

$$\xi_0 = \frac{y_0 - a + 1.645\sigma}{b} \quad , \quad (2.3)$$

where a , b and σ were introduced in Assumption 1.

Now, in addition to Assumption 1 we will make the following one:

Assumption 2

Consider a piece of timber chosen at random from the production line of a sawmill or a timber yard. The EP-value ξ of the chosen piece is a random variable with probability density, say $f_{\xi}(t)$, and the corresponding strength y is a random variable with probability density, say $f_y(t)$.

We can now calculate the conditional probability $P(y \leq y_0 | \xi \leq \xi_0)$, i.e. the probability that a piece which has been judged as acceptable by the grading procedure, would not be acceptable by the ideal criterion. We are going to use this quantity as an efficiency measure of the grading procedure.

By Assumption 1, 2 and standard probability theory we have

$$P(y \leq y_0 | \xi \leq \xi_0) = \frac{\int_{-\infty}^{\xi_0} f_{\xi}(t) \Phi\left(\frac{y_0 - a - bt}{\sigma}\right) dt}{\int_{-\infty}^{\xi_0} f_{\xi}(t) dt}, \quad (2.4)$$

which by (2.2) takes the form

$$P(y \leq y_0 | \xi \leq \xi_0) = \frac{\int_{-\infty}^{\xi_0} f_{\xi}(t) \Phi\left(\frac{b(\xi_0 - t) - 1.645\sigma}{\sigma}\right) dt}{\int_{-\infty}^{\xi_0} f_{\xi}(t) dt}, \quad (2.5)$$

where Φ is the (cumulative) normal distribution function. Obviously $P(y \leq y_0 | \xi \leq \xi_0)$ depends, among other things, on the form of $f_{\xi}(t)$. In this paper we will calculate $P(y \leq y_0 | \xi \leq \xi_0)$ for different conditions on $f_{\xi}(t)$.

In the above grading procedure we have assumed that EP can be measured without error for each piece of timber. Obviously, that is not a very realistic assumption. We now assume that for a piece with "true" EP = ξ the EP-value x , $x \neq \xi$, is registered. Thus EP is estimated with an error.

The main aim of this paper is to investigate how the efficiency of the grading procedure is affected if x is used instead of ξ , i.e. a piece is classified as acceptable if $x \leq \xi_0$ and not acceptable if $x > \xi_0$.

More specifically, we will compare $P(y \leq y_0 | x \leq \xi_0)$ (efficiency of the "practical" grading) to $P(y \leq y_0 | \xi \leq \xi_0)$ (efficiency of the "theoretical" grading) for different conditions on the measurement error $x - \xi$.

Section 2 treats the case of a systematic error (e.g. if the grading is made by an accurate but poorly calibrated machine) and Section 3 treats the case of a random error (e.g. if the grading is made visually by a skilled worker).

3. THE CASE OF A SYSTEMATIC ERROR

In this section we will assume that $\xi = x + \Delta$, where $\Delta > 0$ is a constant, i.e. the quantity EP is measured with a systematic error. Then

$P(y \leq y_0 | x \leq \xi_0) = P(y \leq y_0 | \xi \leq \xi_0 + \Delta)$ and thus, by (2.5):

$$P(y \leq y_0 | x \leq \xi_0) = \frac{\int_{-\infty}^{\xi_0 + \Delta} f_{\xi}(t) \Phi\left(\frac{b(\xi_0 - t) - 1.645\sigma}{\sigma}\right) dt}{\int_{-\infty}^{\xi_0 + \Delta} f_{\xi}(t) dt} \quad (3.1)$$

Now, in order to compare $P(y \leq y_0 | x \leq \xi_0)$ to $P(y \leq y_0 | \xi \leq \xi_0)$ numerically we must know (or assume) the form of $f_{\xi}(t)$. In the following numerical examples we will consider two different distribution forms of ξ ; normal and uniform respectively. Furthermore we will assign the following numerical values to the parameters involved (cf. the discussion in Section 2): $b = -50$, $\sigma = 6$, $\xi_0 = 0.5$, $\Delta = 0.05$ (which means that there is a 10% relative error in the permissible limit). The ξ_0 -value corresponds fairly well to a Swedish middle structural grade.

a) Normal distribution: In this case we assume that ξ is $N(\mu_{\xi}, \sigma_{\xi})$ which means that $f_{\xi}(t) = \frac{1}{\sigma_{\xi}} \varphi\left(\frac{t - \mu_{\xi}}{\sigma_{\xi}}\right)$ where φ is the normal density function.

Then (3.1) and (2.5) respectively take the forms

$$P(y \leq y_0 | x \leq \xi_0) = \frac{\int_{-\infty}^{\xi_0 + \Delta} \frac{1}{\sigma_{\xi}} \varphi\left(\frac{t - \mu_{\xi}}{\sigma_{\xi}}\right) \Phi\left(\frac{b(\xi_0 - t) - 1.645\sigma}{\sigma}\right) dt}{\Phi\left(\frac{\xi_0 + \Delta - \mu_{\xi}}{\sigma_{\xi}}\right)}, \quad (3.2)$$

and

$$P(y \leq y_0 | \xi \leq \xi_0) = \frac{\int_{-\infty}^{\xi_0} \frac{1}{\sigma_\xi} \varphi\left(\frac{t - \mu_\xi}{\sigma_\xi}\right) \Phi\left(\frac{b(\xi_0 - t) - 1.645\sigma}{\sigma}\right) dt}{\Phi\left(\frac{\xi_0 - \mu_\xi}{\sigma_\xi}\right)} \quad (3.3)$$

We have evaluated (3.2) and (3.3) in some practical cases, presented in Table 3.1. ξ is $N(\mu_\xi, \sigma_\xi)$, i.e. μ_ξ and σ_ξ are the average and standard deviation respectively of the knot area ratio. $P(\xi \leq \xi_0)$ is the probability that a piece is judged as acceptable by the "theoretical" grading.

$P(y \leq y_0 | \xi \leq \xi_0)$ is the probability that a piece which has been judged as acceptable by the "theoretical" grading would not be acceptable by the "ideal" quality criterion. The quantities $P(x \leq \xi_0)$ and $P(y \leq y_0 | x \leq \xi_0)$ are interpreted correspondingly ("theoretical grading" changed to "practical grading").

Case	μ_ξ	σ_ξ	$P(\xi \leq \xi_0)$	$P(x \leq \xi_0)$	$P(y \leq y_0 \xi \leq \xi_0)$	$P(y \leq y_0 x \leq \xi_0)$
1	0.30	0.10	98%	99%	0.3%	0.4%
2	0.40	0.15	75%	84%	0.8%	1.5%
3	0.50	0.15	50%	63%	1.2%	2.5%
4	0.50	0.05	50%	84%	2.7%	4.6%
5	0.60	0.15	25%	37%	1.6%	3.6%
6	0.60	0.05	2%	16%	3.7%	7.6%

TABLE 3.1: Efficiency of the practical vs the theoretical grading.

ξ is $N(\mu_\xi, \sigma_\xi)$. The EP-variable subjected to a systematic error $\Delta = 0.05$. Permissible limit $\xi_0 = 0.5$.

The efficiency of the practical as well as the theoretical grading depends on the parameters μ_ξ and σ_ξ in quite a complicated way. This can be seen from (3.2) and (3.3) respectively. Now, the following relations are readily verified.

$$P(\xi \leq \xi_0) = \Phi\left(\frac{\xi_0 - \mu_\xi}{\sigma_\xi}\right) \quad (3.4)$$

$$P(x \leq \xi_0) = \Phi\left(\frac{\xi_0 + \Delta - \mu_\xi}{\sigma_\xi}\right) \quad (3.5)$$

We have chosen (by using (3.4) and (3.5)) the parameters μ_ξ and σ_ξ in Table 3.1 as to satisfy the following requirements.

Case 1: $P(\xi \leq \xi_0) = 0.98$, i.e. practically all the pieces in the package would be accepted by the theoretical grading. Furthermore, $P(x \leq \xi_0) = 0.99$ so the additional proportion accepted by the practical grading (in relation to that accepted by the theoretical grading) is very small. This is a case where the fact that grading must be done by x instead of ξ would cause very few problems.

Case 2 illustrates a package of good timber (relative to the permissible limit $\xi_0 = 0.50$) since $P(\xi \leq \xi_0) = 0.75$. Furthermore, $P(x \leq \xi_0) = 0.84$ so the additional proportion accepted by the practical grading is substantial.

Cases 3 and 4 illustrate cases of "medium quality timber", $P(\xi \leq \xi_0) = 0.50$ where the level of the additional proportion accepted by the practical grading is increased in case 4 compared to case 3.

Case 5 corresponds to Case 2, the only real difference being that $P(\xi \leq \xi_0) = 0.25$ instead of 0.75, due to a larger average knot area ratio.

Case 6 illustrates a package of poor timber; $P(\xi \leq \xi_0) = 0.02$. The additional proportion accepted by the practical grading (in relation to 0.02) is substantial.

As seen from the cases in Table 3.1 the efficiency loss induced by the practical grading can be considerable.

In Table 3.1 we have chosen to vary the parameters μ_ξ and σ_ξ while ξ_0 and Δ are kept fixed.

Alternative modes of study are certainly possible, e.g. keeping μ_ξ , σ_ξ and ξ_0 fixed, while Δ is varied, or keeping μ_ξ and ξ_0 fixed while σ_ξ and Δ are varied etc. However, we have confined ourselves to the mode presented in Table 3.1 and leave the alternative modes of study to the reader.

b) Uniform distribution: Here we assume that ξ is uniformly distributed on an interval (ξ_{\min}, ξ_{\max}) , i.e.

$$f_{\xi}(t) = \begin{cases} \frac{1}{\xi_{\max} - \xi_{\min}} & \text{if } \xi_{\min} \leq t \leq \xi_{\max} \\ 0 & \text{otherwise} \end{cases} \quad (3.6)$$

We also assume that

$$\xi_{\min} < \xi_0 < \xi_0 + \Delta < \xi_{\max} . \quad (3.7)$$

We have imposed this condition only to exclude some trivial cases. If $\xi_{\min} \geq \xi_0$ then the theoretical grading would reject all the pieces in the package, while if $\xi_0 + \Delta \geq \xi_{\max}$ the practical grading would accept all the pieces. The condition (3.7) guarantees that there are acceptable as well as unacceptable pieces (by both grading criteria) in the package. It is readily shown that (3.1) takes the form

$$P(y \leq y_0 | x \leq \xi_0) = \frac{\int_{\xi_{\min}}^{\xi_0 + \Delta} \phi\left(\frac{b(\xi_0 - t) - 1.645\sigma}{\sigma}\right) dt}{(\xi_0 + \Delta - \xi_{\min})} \quad (3.8)$$

while (2.5) takes the form

$$P(y \leq y_0 | \xi \leq \xi_0) = \frac{\int_{\xi_{\min}}^{\xi_0} \phi\left(\frac{b(\xi_0 - t) - 1.645\sigma}{\sigma}\right) dt}{(\xi_0 - \xi_{\min})} \quad (3.9)$$

Note that (3.8) and (3.9) are independent of ξ_{\max} . This is due to the special form of the uniform probability density.

We have evaluated (3.8) and (3.9) for different chosen values of ξ_{\min} as presented in Table 3.2.

Case	ξ_{\min}	$P(y \leq y_0 \xi \leq \xi_0)$	$P(y \leq y_0 x \leq \xi_0)$
1	0.00	0.5%	1.1%
2	0.10	0.6%	1.4%
3	0.20	0.8%	1.8%
4	0.30	1.2%	2.5%
5	0.40	2.2%	4.0%
6	0.45	3.3%	5.4%

TABLE 3.2: Efficiency of the practical vs the theoretical grading. ξ is uniformly distributed. The EP-variable subjected to a systematic error $\Delta = 0.05$. Permissible limit $\xi_0 = 0.5$

As seen from Table 3.2 the efficiency of the practical grading (with a systematic error) can be notably less than that of the theoretical one also in the case of a uniformly distributed EP.

c) Remarks: Obviously our numerical results depend on the parameters Δ , ξ_0 , b , σ , μ_ξ and σ_ξ as well as the form of $f_\xi(t)$. Other values of these quantities will yield different numerical results than the ones presented above. However, our examples show that systematic measurement errors in the EP-variable may lead to a notable loss in grading efficiency. We believe that an analysis along the lines presented here is helpful when judging the size of such a loss or when judging whether the permissible limit should be changed or not.

4. THE CASE OF A RANDOM ERROR

In this section we will make the following assumption (in addition to the ones in Section 2).

$$\begin{array}{l}
 x = \xi + \delta \\
 \text{where} \\
 \begin{array}{l}
 \text{(i) } \xi \text{ is } N(\mu_\xi, \sigma_\xi) \\
 \text{(ii) } \delta \text{ is } N(0, \sigma_\delta) \\
 \text{(iii) } \xi \text{ and } \delta \text{ are statistically independent.}
 \end{array}
 \end{array} \quad (4.1)$$

We will confine ourselves to the case of normally distributed ξ , in contrast to Section 3, where we studied normally as well as uniformly distributed ξ . The main reason for this is that the computation of $P(y \leq y_0 | x \leq \xi_0)$ becomes quite extensive in the random error case unless ξ is normally distributed. Besides, a comparison of Tables 3.1 and 3.2 indicates that the distribution form of ξ should not substantially affect the main conclusions of the analysis.

It follows from (4.1) that $P(y \leq y_0 | \xi \leq \xi_0)$ takes the same form as in (3.3). Furthermore,

$$x \text{ is } N(\mu_\xi, \sqrt{\sigma_\xi^2 + \sigma_\delta^2}) . \quad (4.2)$$

It is then straightforward to show that

$$P(y \leq y_0 | x \leq \xi_0) = \frac{\int_{-\infty}^{\xi_0} P(y \leq y_0 | x=t) \frac{1}{\sqrt{\sigma_\xi^2 + \sigma_\delta^2}} \phi\left(\frac{t - \mu_\xi}{\sqrt{\sigma_\xi^2 + \sigma_\delta^2}}\right) dt}{\Phi\left(\frac{\xi_0 - \mu_\xi}{\sqrt{\sigma_\xi^2 + \sigma_\delta^2}}\right)} \quad (4.3)$$

Now, it can be shown (see Appendix) that

$$P(y \leq y_0 | x=t) = \Phi\left(\frac{b(\xi_0 - \mu_\xi) - 1.645\sigma - b\left(\frac{\sigma_\xi^2}{\sigma_\xi^2 + \sigma_\delta^2}\right)(t - \mu_\xi)}{\sqrt{\sigma^2 + b^2\left(\frac{\sigma_\xi^2 \sigma_\delta^2}{\sigma_\xi^2 + \sigma_\delta^2}\right)}}\right) \quad (4.4)$$

Inserting (4.4) into (4.3) yields $P(y \leq y_0 | x \leq \xi_0)$. We have evaluated this quantity as well as $P(y \leq y_0 | \xi \leq \xi_0)$, (see (3.3)) for different combinations of the parameters involved. The following parameters were fixed: $b = -50$, $\sigma = 6$, $\xi_0 = 0.50$, $\sigma_\delta = 0.05$, while μ_ξ and σ_ξ were chosen in the same way as in Table 3.1. This way we get cases comparable to those in Table 3.1, the only difference being that ξ was subjected to a systematic error while here ξ is subjected to a random error. The results are presented in Table 4.1.

Case	μ_ξ	σ_ξ	$P(\xi \leq \xi_0)$	$P(x \leq \xi_0)$	$P(y \leq y_0 \xi \leq \xi_0)$	$P(y \leq y_0 x \leq \xi_0)$
1	0.30	0.10	98%	96%	0.3%	0.3%
2	0.40	0.15	75%	74%	0.8%	1.0%
3	0.50	0.15	50%	50%	1.2%	1.8%
4	0.50	0.05	50%	50%	2.7%	3.7%
5	0.60	0.15	25%	26%	1.6%	2.7%
6	0.60	0.05	2%	8%	3.7%	9.6%

TABLE 4.1: Efficiency of the practical vs the theoretical grading. ξ is $N(\mu_\xi, \sigma_\xi)$. The EP-variable subjected to a random error which is $N(0, 0.05)$. Permissible limit $\xi_0 = 0.50$.

The interpretation of the quantities in Table 4.1 is the same as that of Table 3.1 (see Section 3).

By comparing Table 4.1 to Table 3.1 it is seen that a random error in the EP-variable may lead to an efficiency loss of comparable size to the case of a systematic error (all other conditions equal).

5. CONCLUSIONS

The conditions that have been illustrated here by some examples show that the tolerances permitted by grading of structural timber, may influence the risk level for ruptures considerably. It is therefore necessary to take this into consideration when determining the permitted stresses or conversely when working out a grading system and rules of control for the grading, so that the deviations permitted have a magnitude and design that do not jeopardize the intended risk level.

References

Instruktion för sortering och märkning av T-virke. T-virkesföreningen, Stockholm, 1981.

Western Lumber Grading Rules. Western Wood Products Association, Portland, Oregon, USA, 1979.

NLGA Structural Grading Rules for Canadian Lumber. National Lumber Grades Authority, Vancouver, BC, Canada, 1978.

Timber grades for structural use, BS 4978: 1973 with amendments. British Standards Institution, London, 1979.

Grading Errors in Practice, Bertil Thunell, Report 14, Royal Institute of Technology, Wood Technology and Processing, Stockholm, Sweden, 1982.

Metoder att visuellt bestämma kvistars inverkan på hållfastheten hos virke, Methods to determine the effect of knots on the strength of timber by visual inspection. Swedish Forest Products Research Laboratory, Bulletin A 551, Stockholm, 1979.

Appendix

The aim here is to prove formula (4.4). We will base the proof on the following well known result which appears in most statistical textbooks.

Theorem: Suppose that z_1 and z_2 are $N(m_1, \sigma_1)$ and $N(m_2, \sigma_2)$ respectively and that the correlation between z_1 and z_2 is ρ . Then the conditional distribution of z_2 given $z_1 = t$ is $N(m_2 + \rho \cdot \frac{\sigma_2}{\sigma_1}(t - m_1); \sigma_2 \sqrt{1 - \rho^2})$.

Assumption 1 and the fact that ξ is $N(\mu_\xi, \sigma_\xi)$ imply that y is $N(a + b\mu_\xi, \sqrt{\sigma^2 + b^2\sigma_\xi^2})$.

Then by the above theorem the conditional distribution of y , given $x = t$ is $N(a + b\mu_\xi + \rho_{y,x} \cdot \frac{\sigma_y}{\sigma_x}(t - \mu_\xi); \sigma_y \sqrt{(1 - \rho_{y,x}^2)})$

where

$$\begin{aligned}\sigma_x^2 &= \sigma_\xi^2 + \sigma_\delta^2 \\ \sigma_y^2 &= \sigma^2 + b^2\sigma_\xi^2 \\ \rho_{y,x} &= \frac{E(yx) - E(y)E(x)}{\sigma_y \sigma_x} = \frac{b\sigma_\xi^2}{\sigma_y \sigma_x}\end{aligned}$$

Then the conditional distribution is

$$N\left(a + b\mu_\xi + \frac{b\sigma_\xi^2}{\sigma_\xi^2 + \sigma_\delta^2}(t - \mu_\xi); \sqrt{\sigma^2 + b^2 \left(\frac{\sigma_\xi^2 \sigma_\delta^2}{\sigma_\xi^2 + \sigma_\delta^2}\right)}\right)$$

and (4.4) follows immediately.

INTERNATIONAL COUNCIL FOR BUILDING RESEARCH STUDIES AND DOCUMENTATION
WORKING COMMISSION W18 - TIMBER STRUCTURES

SIZE FACTORS FOR
TIMBER BENDING AND TENSION STRESSES

by

A R Fewell

Building Research Establishment
Princes Risborough Laboratory
United Kingdom

LILLEHAMMER

NORWAY

MAY/JUNE 1983

INTERNATIONAL COUNCIL FOR BUILDING RESEARCH STUDIES AND DOCUMENTATION
WORKING COMMISSION W18 - TIMBER STRUCTURES

SIZE FACTORS FOR
TIMBER BENDING AND TENSION STRESSES

by

A R Fewell

Building Research Establishment
Princes Risborough Laboratory
United Kingdom

LILLEHAMMER
NORWAY
MAY/JUNE 1983

INTERNATIONAL COUNCIL FOR BUILDING RESEARCH STUDIES AND DOCUMENTATION
WORKING COMMISSION W18 - TIMBER STRUCTURES

SIZE FACTORS FOR
TIMBER BENDING AND TENSION STRESSES

by

A R Fewell

Building Research Establishment
Princes Risborough Laboratory
United Kingdom

LILLEHAMMER
NORWAY
MAY/JUNE 1983

SIZE FACTORS FOR TIMBER BENDING AND TENSION STRESSES

A R Fewell - PRL

INTRODUCTION

The writer was asked to present a paper for the CIB-W18 meeting in Norway 1983 on size factors. Fewell and Curry¹ have written a paper which analyses existing PRL and Canadian data to examine the effect of depth in the determination of characteristic bending stresses. That paper is to be published in The Structural Engineer but due to delays in publication some of the information in that paper has been outdated by committee decisions in producing the final draft of the revised Code of Practice for timber structures, BS 5268:Part 2². Rather than re-produce the data analysis of that paper, this short note updates it by pointing out the subsequent committee changes and adds information on the adjustment of bending and tension design stresses given in BS 5268. The Fewell and Curry paper is attached as an appendix.

CHANGES IN DRAFTING BS 5268

The Fewell and Curry paper gives no information on size adjustments to tension stresses and states that no bending stress adjustment will be allowed for sizes smaller than 300 mm. In fact the BS 5268 drafting committee subsequently decided that both bending stresses and tension stresses should be allowed to increase for depths or widths less than 300 mm. The reason for this decision was to overcome the low tension stresses derived from analysis of structural size test data.

SIZE FACTORS

To adjust lower fifth percentile stress values to characteristic values factors from the equations $K = (200/h)^{0.4}$ and $K = (200/h)^{0.192}$ were used for bending stress and tension stress respectively by Curry and Fewell³ in their determination of stresses for BS 5268. Where K is the factor by which a bending stress specified for a depth of 200 mm should be multiplied to obtain the stress values for a depth or width of 'h' mm. These characteristic values were further reduced for the derivation of design stresses appropriate to 300 mm which meant that in effect the bending and tension stresses from test samples were being adjusted to the datum width of 300 mm using factors from $K = (300/h)^{0.4}$ and $K = (300/h)^{0.192}$ respectively. Figures 1 and 2 show plots of the data from which

these equations were determined. The considerable amount of scatter in Figure 1 is probably partly due to the fact that only an adjustment for depth is considered whereas the size effect is also dependent on thickness and test method.

Because of the scatter in Figure 1, use of the above equation $K = (300/h)^{0.4}$ to adjust design stresses given in BS 5268 for 300 mm depth to smaller depths could prove to be unsafe. Additionally for simplicity it was thought desirable that one equation should be given for both bending and tension and for all grades, whether visual or machine.

Machine grading is based on selection with respect to modulus of elasticity and there is no theoretical reason why a size effect for timber selected on this basis should be the same as for timber selected on the basis of knots. In fact for machine grading a depth effect described by the equation $K = 0.81 (h^2 + 92300)/(h^2 + 56800)$ currently given in CP 112:Part 2⁴ appears to fit the data very well. This equation gives a smaller size effect than $K = (300/h)^{0.4}$.

It was therefore decided that BS 5268:Part 2 should allow bending and tension stresses to be increased for depths or widths less than 300 mm using factors calculated from $K = (300/h)^{0.11}$. The increase would become a maximum at a depth or width of 72 mm. This equation was derived theoretically by Bohannan⁵ and is generally conservative for visual grades as can be seen from Figures 1 and 2 but is less conservative for machine grades.

April 1983

REFERENCES

- 1 Fewell, A R and Curry, W T. Depth factor adjustments in the determination of characteristic bending stresses for visually stress graded timber. PRL 1982.
- 2 British Standard BS 5268:Part 2:draft document 82/14091 Code of Practice for the Structural Use of Timber. BSI.
- 3 Curry, W T and Fewell, A R. Grade stress values for BS 5268 - second revision. PRL 1981.
- 4 British Standard BS CP 112:Part 2:1971. Code of Practice for the Structural Use of Timber. BSI.
- 5 Bohannon, W. Effect of size on bending strength of wood beams. US FPL Bull No 56, 1966.

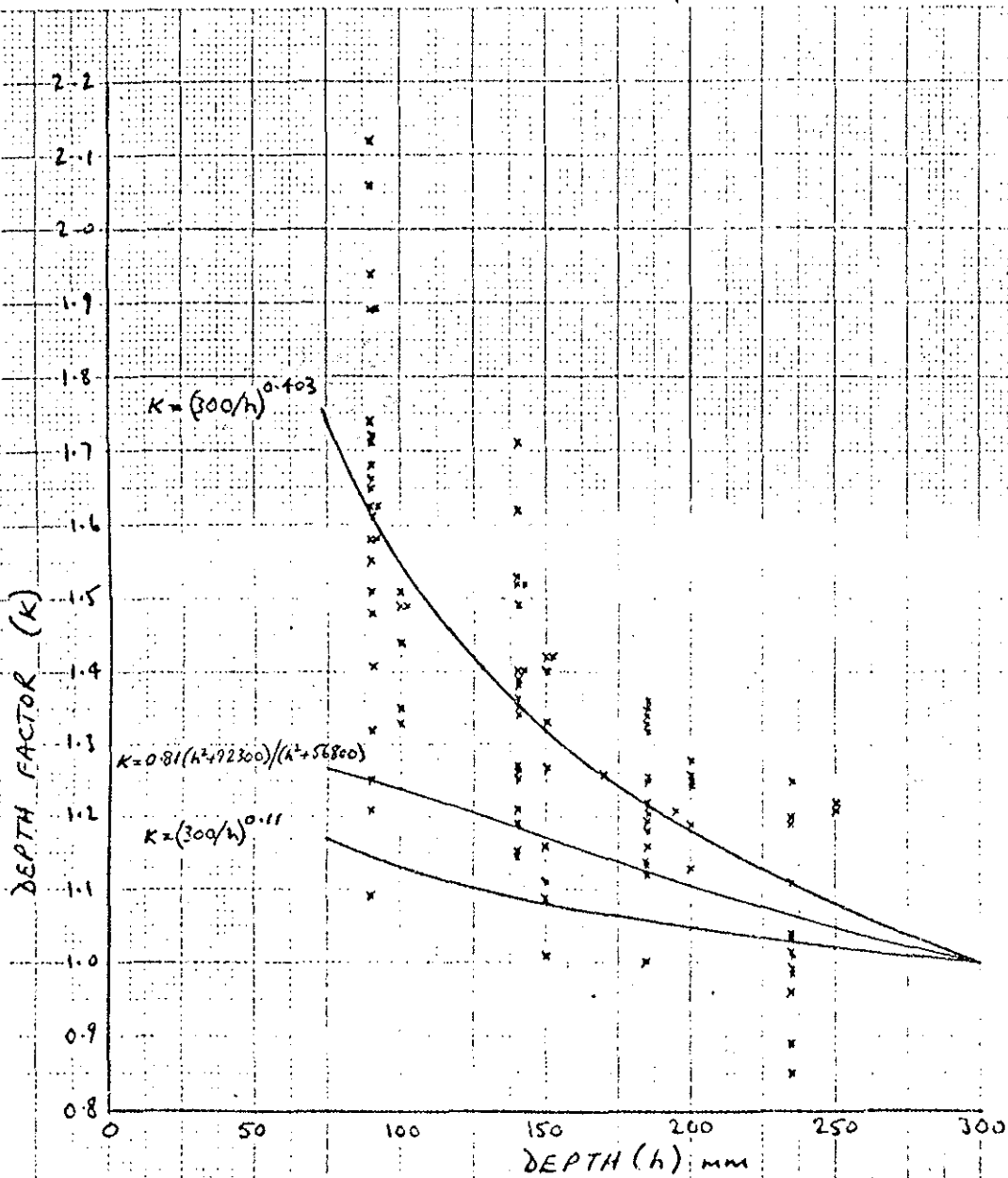

FIG 1 LOWER FIFTH PERCENTILE VALUES OF BENDING STRENGTH FOR VISUAL GRADES

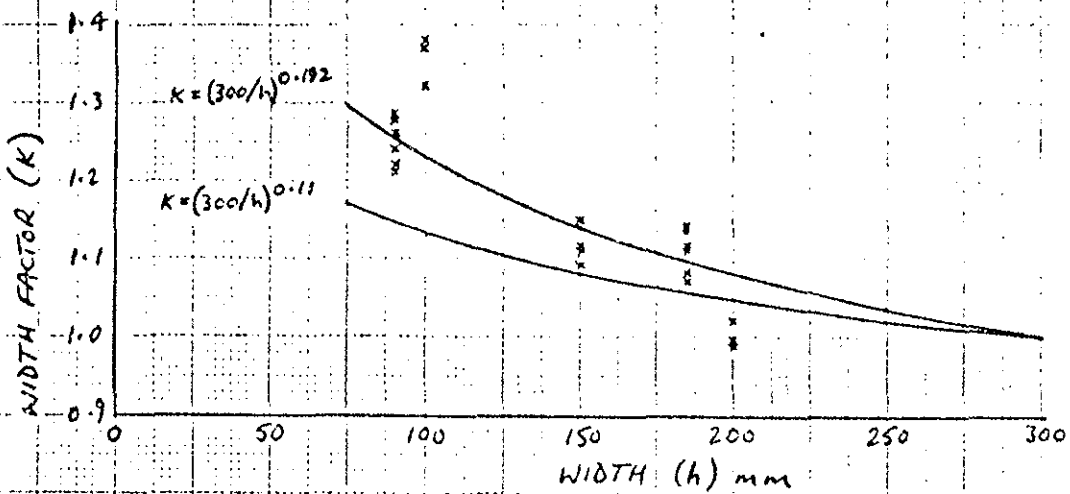

FIG 2 LOWER FIFTH PERCENTILE VALUES OF TENSION STRENGTH FOR VISUAL GRADES

APPENDIX

DEPTH FACTOR ADJUSTMENTS IN THE DETERMINATION OF CHARACTERISTIC BENDING STRESSES FOR VISUALLY STRESS GRADED TIMBER

A R Fewell and W T Curry

SUMMARY

This paper examines the application of equations used to define the effect of section depth on the ultimate bending stress of timber to characteristic stress values obtained from tests carried out at PRL and in Canada. It deals specifically with the determination of the most suitable general equation for adjusting test results to a standard depth. From a comparison of root mean square differences between depth factors obtained from the test results, and those predicted by the equations, it is concluded that for visually stress graded softwood timber the depth effect is best defined by the equation $K = (200/h)^{0.4}$

INTRODUCTION

It has long been recognised that the modulus of rupture or ultimate bending stress of timber is lower for larger than for smaller sections. Although factors other than depth are also involved the effect has come to be known as a depth effect which must be quantified so that it can be allowed for in design, and in the determination of the stress values to be specified for timber. These stress values will generally be determined from tests on samples of timber in different sizes and the values specified will be for some arbitrarily chosen depth.

This paper deals with depth effect on sections up to 300 mm deep and is concerned principally with the determination of grade characteristic stresses rather than modification factors for use in design where much deeper sections would also have to be covered. However, consideration might be given to the inclusion of depth factors in future Codes of Practice for sections shallower than 300 mm. With such factors some of the differences between European and North American grade stress specifications could be eliminated, and much simpler stress tables could be produced for the Codes.

Depth effect was first investigated by Newlin and Trayer in 1924¹. In 1954 Freas and Selbo² published the results of tests on beams with depths up to 406 mm (16 inches) and derived an equation which defined a depth effect ratio indexed to 1.0 at 50 mm (2 inches), the depth of section specified at that time in the standard test procedures for the determination of timber strength properties. This equation was included in North American design methods and was subsequently adopted in the UK Code of Practice for the structural use of timber in 1967. For design purposes the equation was indexed to 1.0 at a 12 inch depth but this was later changed to 300 mm when the UK Code was metricated in 1971³.

Recently a section depth of 200 mm has become the preferred standard depth for the specification of timber bending stress values in many countries and indexing the equation to this depth gives:

$$K = 0.73 (h^2 + 92\,300)/(h^2 + 56\,800) \dots\dots\dots (1)$$

where K is the factor by which a bending stress specified for a depth of 200 mm should be multiplied to obtain the stress values for a depth of 'h' mm.

A theoretical study by Bohannon⁴ in 1966 using the Weibull 'weakest link' theory produced the equation currently used in North American design:

$$K = (200/h)^{1/9} \dots\dots\dots (2)$$

This equation is also indexed to 1.0 at 200 mm and suggests a depth effect which is somewhat less severe than equation (1) over the normal range of joist sizes.

The results of an extensive investigation made in Canada in 1977/8 were analysed by Bury⁵ and Madsen⁶ who produced sets of equations for the effect of depth on the characteristic ie 5th percentile values of bending stress for timber in standard joist sizes and visually stress graded to the NLGA rules⁷. The object of these analyses was to obtain factors to permit test results for different section depths to be adjusted to a standard depth for the determination of grade characteristic stress values. Their equations were grade related but when combined and indexed to 1.0 at 200 mm give:

for Bury

$$K = (200/h)^{0.403} \dots\dots\dots (3)$$

and for Madsen

$$K = 1.631 - 0.00316 h \dots\dots\dots (4)$$

Equation (3) was obtained by pooling all the test results while equation (4) is simply the average of the slopes and intercepts of the separate grade equations. The four depth factor equations are illustrated in Figure 1.

The purpose of this paper is to identify using the PRL and Canadian test data the equation which gives the best overall definition of depth effect.

Test Data

PRL Data. The test procedures that were used are those now given in BS 5820:1979⁸. The tests covered samples of Swedish and Finnish redwood/whitewood, British grown Douglas fir and Canadian hem-fir and spruce-pine-fir graded to the BS 4978⁹ and NLGA stress grades. The test specimens were conditioned to a moisture content of 14 to 17% and the tests were carried out under laboratory conditions with no

adjustments made to the results for the differences in moisture contents. A span to depth ratio of 18 was used, the load was applied at the third points of the span and the duration of each test was about 15 minutes. The grade determining defect in each test specimen was located within the zone of maximum stress.

From the test results characteristic bending stresses were calculated for each sample using 3-parameter Weibull functions. Where more than one sample of a particular section depth, species and grade was tested the characteristic stress was taken as the weighted average of the sample values. The resulting stress values are given in Table 1.

Canadian data. A proof loading test was used to determine values of ultimate bending stress at the lower end of the range in strength expected for each species and grade. For this test the proof load was set and adjusted as necessary, to break only about 10% of the specimens that were tested.

The load was applied at a rapid rate and the value attained when fracture occurred was recorded. The species tested were Douglas fir-larch, hem-fir and spruce-pine-fir, and the specimens were selected from mill production. The tests were carried out at the mills and the timber covered a wide range in moisture contents, from 10% to green, with temperatures ranging from -17°C to 13°C . A span to depth ratio of 17 was used, the load was applied at the third points of the span and each test lasted generally less than one minute. No positive action was taken to locate the grade determining defect in each test specimen within the zone of maximum stress. The full test programme involved the testing of some 4000 specimens, but the number of specimens in each sample is not known.

In the Bury analysis the individual test results were adjusted to 15% moisture content. A procedure was developed for fitting 3-parameter Weibull functions to the test data and this was used to calculate characteristic stress values for each of the samples. In the Madsen analysis no adjustments were made to the test results for moisture content differences and a ranking procedure, involving fitting a straight line to the results close to the 0.05 probability point, was used to determine the sample characteristic stresses. Of the two sets of data, that produced by Bury was taken as defining the Canadian species and grades. For those species and grades where more than one sample was tested for a particular depth, the average value of the sample characteristic stress values was taken as the value appropriate to that depth. A summary of the stress values is given in Table 2.

The Canadian and PRL test procedures are obviously quite different and there must be some uncertainty that the test results are directly comparable. However, it is the relativity of the stress values at the different section depths and not their magnitude which is of interest.

Analysis

In the following analysis three questions are examined:

- a is there a grade effect
- b which type of equation best defines depth effect, and
- c can this type of equation be improved for general use.

It should be noted that equation (2) is of the same type as equation (3) so that three and not four types have to be considered. A decision has also to be made as to what criterion should be used to assess the relative effectiveness of the equations. For this the root mean square differences ie the square root of the mean of the sums of the squares of the differences between the depth factors determined from the tests and those predicted by the equations, is generally used.

Grade Effect. Table 3 gives the depth factor equations for the NLGA grades determined by Bury and Madsen. These are illustrated in Figure 2 from which it can be seen that while there are large differences in the factors defined by the two types of equations, the sequence of the equations does not match the grade strength sequence and the differences between the equations of the same type are quite small, less than 4% over the range of joist sizes. These differences are of no practical significance.

To extend the comparison best-fit equations of the three types, for characteristic stress against depth, were calculated for those species and grades for which more than three samples of timber were tested. From a comparison of variances for equations type (2, 3) and (4) no statistically significant interaction between grade and section depth was found, with the single exception of the type (4) equations for Douglas fir-larch. Also, as measured by the percentage of total variance accounted for by the equations, the type (2,3) equations fit the test data better, on the whole, than the type (4) equations.

The individual best-fit equations were also converted to depth factor equations indexed to 1.0 at 200 mm. These are given in Table 4, together with the 200 mm characteristic stress values calculated from the equations. Examination of the equations shows that the effect of depth on the different grades is not consistent between species as might be expected. For example, the equations indicate that with the NLGA grades the depth effect is greatest for:

- 1 the Sel grade of Douglas fir-larch
- 2 the No 3 grade of hem-fir, and
- 3 the No 1 grade of spruce-pine-fir.

For the UK data the differences in the values of the depth factors for each of the grades as defined by equations of the same type are, as with the Canadian data, quite small, being less than 5% over the range of joist sizes.

In any assessment of depth effect the method used to stress grade the timber can in itself influence the results. Not only are the samples of timber that are tested likely to contain greater or lesser numbers of pieces with defects towards the maximum size permitted for the grade, but the effect of the defects themselves may differ with the size of the section. With visual stress grading there is also no control over the density of the material selected within a grade, and this can have a significant effect on strength. The influence of these factors cannot be isolated from the gross effect attributed to depth so that not only is it uncertain that like is being compared with like, but the measured effect of depth may well be different between visual and machine stress grading, and between softwoods and hardwoods. On the basis of the above comparisons it is concluded that any grade related effect is small and may be ignored.

Type of Equation To compare the effectiveness of the three types of equation the characteristic stresses for a standard depth of 200 mm were determined for each species and grade. The general equations (1), (3) and (4) were used to adjust the individual stresses for each section depth to 200 mm, and the resulting values were averaged to obtain the characteristic stresses for the species and grades.

For the PRL data where the strength of each specimen is known and therefore could be included in one sample for each grade and depth, the average was obtained by weighting the individual sample stresses by the number of specimens in each sample. For the Canadian data which comprises multiple samples for some grade/depth combinations with a similar but unknown number of specimens, the average was obtained by weighting the stresses for each depth by the number of samples.

The results are included in Tables 5 and 6. The characteristic stresses for each section depth, as given in Tables 1 and 2, were then expressed as ratios of these grade characteristic stresses to give values of depth factor for the test results. These factors are included in Tables 5 and 6.

The root mean square differences between the test values of depth factor and those given by the equations were then calculated and are given in Table 7 for each species and grade.

The use of equation (1), as indicated in Tables 5 and 6, leads to higher grade characteristic stresses than those obtained with equations (3) and (4). However, as can be seen from Table 7 it has a much higher overall root mean square difference, and in only 7 out of the 19 species/grade combinations has it a lower value than either equations (3) or (4). Equation (1) is therefore in less accord with the test evidence and since it yields higher stress values it would be imprudent to use it when deriving grade characteristic stresses from test results on a range of joist sizes. As to which of the other two equations should be preferred the evidence is less convincing. A comparison shows that equation (3) has a lower root mean square difference in 11 out of the 19 species/grade combinations, and a slightly lower value overall. On this marginal superiority it must be considered preferable to use equation (3) for determining what grade stress values should be specified for timber at a standard section depth.

Modified Equation Equations (2) and (3) are of the same type, the exponent 'b' having the values of $1/9$ (0.111) and 0.403 respectively. To determine the value of 'b' which best fits the test data, species/grade characteristic stress values and root mean square differences were calculated as before for a series of similar equations with 'b' increasing from 0.1 to 0.5 in increments of 0.01. The results are shown graphically in Figure 3 from which it can be seen that the root mean square difference is least when $b = 0.39$. This is close to the value for equation (3) and for general use a value of 0.4 should be adopted for 'b' to give the equation

$$K = (200/h)^{0.4}$$

Conclusions

From the results of this analysis it is concluded that:

- 1 The effect of section depth on the characteristic bending stress of visually stress-graded softwood timber, in sections from about 100 to 300 mm deep, can be defined by the general equation

$$K = (200/h)^{0.4}$$

where K is the factor by which (a) the stress value obtained from tests on sections with a depth of 'h' mm should be divided to obtain the stress corresponding to a depth of 200 mm or (b) the stress value for a section depth of 200 mm should be multiplied to obtain the corresponding stress for a section depth of 'h' mm.

- 2 In applying the general equation no distinction need be made between species or visual grade.

REFERENCES

- 1 Newlin, J. A. and Trayer, G. W.: 'Form factor of beams subjected to transverse loading only', NACA Report No 181, 1924
- 2 Freas, A. D. and Selbo, M. L.: 'Fabrication and design of glued laminated wood structural members', United States Department of Agriculture Technical Bulletin No 1069:1954
- 3 British Standards Institution.: 'The structural use of timber', British Standard Code of Practice CP 112:Part 2:1971
- 4 Bohannon, W.: 'Effect of size on bending strength of wood beams', United States Forest Products Laboratory Bulletin No 56, 1966
- 5 Bury, K. V.: 'Statistical analysis of NLGA bending tests', University of British Columbia, Canada, 1981
- 6 Madsen, B. and Nielson, P. C.: 'In-grade testing', Bending tests in Canada June 77-May 78, University of British Columbia, Canada, 1978
- 7 National Lumber Grades Authority: 'NLGA standard grading rules for Canadian lumber', NLGA, 1979
- 8 British Standards Institution: 'Determination of certain physical and mechanical properties of timber in structural sizes', BS 5820:1979
- 9 British Standards Institution: 'Timber grades for structural use', BS 4978:1973

Table 1 Summary of PRL Test Data

Species	Grade	Depth mm	No of specimens	Characteristic bending stress N/mm ²
Redwood/white- wood	SS	100	214	25.7
		150	1077	24.9
		170	85	24.0
		195	91	23.1
		200	661	23.6
Hem-fir	SS	100	149	27.3
		150	195	23.4
		200	110	21.8
		250	85	22.3
	Sel	100	55	30.7
		150	96	24.4
		200	44	25.2
		250	65	24.9
	No 2	100	79	21.4
		150	65	18.9
		200	39	18.0
	Spruce-pine-fir	SS	88	214
184			264	20.9
Sel		88	180	29.6
		184	237	22.2
No 2		88	40	18.6
		184	26	13.3
British-grown Douglas fir	SS	100	84	21.8
		200	129	18.8

Table 2 Summary of Canadian Test Data

Species	Grade	Depth mm	No of samples	Characteristic bending stress N/mm ²
Douglas fir- larch	Sel	89	2	34.9
		140	2	28.6
		184	2	23.2
		235	2	18.2
	No 1	89	1	25.1
		184	1	15.7
		235	1	11.5
	No 2	89	2	21.3
		140	2	15.3
		184	2	13.4
		235	2	12.0
	No 3	89	1	14.5
140		1	12.8	
184		1	12.5	
235		1	9.1	
Hem-fir	Sel	89	1	29.1
		140	1	28.7
		184	1	26.0
		235	1	18.5
	No 2	89	1	18.9
		140	1	21.8
		184	1	17.6
		235	1	17.1
	No 3	89	1	20.1
140		1	15.5	
184		1	14.3	
235		1	11.7	
Spruce-pine-fir	Sel	89	4	25.4
		140	4	24.5
		184	4	22.9
		235	2	18.2
	No 1	89	2	24.6
		140	2	19.0
		184	2	16.4
	No 2	89	4	20.7
		140	4	17.3
		184	4	16.3
		235	2	15.7
	No 3	89	1	17.2
140		1	13.5	
184		1	10.0	
235		1	12.5	

Table 3 Depth Factor Equations for the NLGA Grades

Grade	Equation (3) Bury	Equation (4) Madsen
Sel	$(200/h)^{0.383}$	1.594-0.00297 h
No 1 and No 2	$(200/h)^{0.361}$	1.608-0.00304 h
No 3	$(200/h)^{0.423}$	1.691-0.00346 h
Combined	$(200/h)^{0.403}$	1.631-0.00316 h

Table 4 Individual depth factor equations and values of characteristic bending stress (N/mm²)

Data source	Species	Grade	Number of samples	Equation type (1)				Equation type (2,3)			Equation type (4)		
				a	b (x 10 ⁻³)	c (x 10 ⁻³)	f	a	b (x -10 ³)	f	a	b (x +10 ⁴)	f
PRL	Hem-fir	SS	5	0.727	70.0	40.0	22.34	3.246	222.2	22.26	1.267	13.3	22.56
		Sel	5	0.750	70.4	42.8	24.67	2.755	191.3	24.53	1.222	11.1	24.91
		No 2	4	0.674	70.4	34.4	17.07	4.159	269.0	17.18	1.397	19.8	17.15
Canada	Douglas fir-larch	Sel	8	0.394	119.2	22.8	21.55	33.435	662.4	21.23	2.057	52.9	21.83
		No 2	8	0.511	70.4	16.4	12.72	22.578	588.3	12.85	1.954	47.7	13.12
		No 3	4	0.485	120.0	37.6	10.83	9.365	422.2	10.75	1.632	31.6	10.92
	Hem-fir	Sel	4	0.501	119.6	40.0	22.94	9.086	416.5	22.48	1.627	31.4	22.85
		No 2	4	0.732	103.2	64.8	18.11	2.019	132.6	18.10	1.212	10.6	18.12
		No 3	4	0.538	71.6	20.0	13.02	16.826	532.8	13.07	1.827	41.3	13.31
	Spruce-pine-fir	Sel	14	0.585	120.0	53.6	21.37	3.911	257.4	21.24	1.409	20.4	21.25
		No 1	6	0.524	70.0	17.6	15.28	17.132	536.2	15.61	2.194	59.7	14.56
		No 2	14	0.649	70.4	31.6	15.80	4.367	278.2	15.91	1.454	22.7	15.99
		No 3	4	0.567	70.0	22.4	11.46	9.444	423.8	11.63	1.606	30.3	11.93

Equation type 1 $K = a(h^2 + b)/(h^2 + c)$

2 & 3 $K = ah^b$

4 $K = a + bh$

Table 5 Depth Factors (K) obtained by expressing the PRL test results as ratios of the species/grade characteristic stress values (f_K N/mm²)

Species	Grade	Depth mm	Equation (1)	Equation (3)	Equation (4)
Redwood/white- wood	SS	100	1.09	1.15	1.17
		150	1.06	1.11	1.13
		170	1.02	1.07	1.09
		195	0.98	1.03	1.05
		200	1.00	1.05	1.07
	f_K	23.5	22.4	22.1	
Hem-fir	SS	100	1.19	1.27	1.26
		150	1.02	1.09	1.08
		200	0.95	1.01	1.01
		250	0.97	1.03	1.03
	f_K	22.9	21.5	21.7	
	Sel	100	1.22	1.28	1.26
		150	0.97	1.02	1.00
		200	1.00	1.05	1.03
		250	0.99	1.04	1.02
	f_K	25.2	24.0	24.4	
	No 2	100	1.16	1.27	1.28
		150	1.02	1.12	1.13
200		0.98	1.07	1.08	
f_K		18.5	16.8	16.7	
Spruce-pine-fir	SS	84	1.26	1.40	1.40
		184	0.92	1.03	1.03
		f_K	22.7	20.4	20.4
	Sel	84	1.25	1.38	1.38
		184	0.94	1.04	1.03
		f_K	23.7	21.4	21.5
	No 2	84	1.23	1.41	1.40
		184	0.88	1.01	1.00
f_K		15.1	13.2	13.3	
British-grown Douglas fir	SS	100	1.14	1.22	1.22
		200	0.99	1.05	1.05
	f_K	19.1	17.9	17.9	

Table 6 Depth factors (K) obtained by expressing the Canadian test results as ratios of the species/grade characteristic stress values (f_K N/mm²)

Species	Grade	Depth mm	Equation (1)	Equation (3)	Equation (4)
Douglas fir- larch	Sel	89	1.41	1.52	1.51
		140	1.15	1.25	1.24
		184	0.94	1.01	1.00
		235	0.73	0.79	0.79
		f_K	24.8	22.9	23.1
	No 1	89	1.52	1.65	1.62
		184	0.95	1.03	1.01
		235	0.69	0.76	0.74
		f_K	16.6	15.2	15.5
	No 2	89	1.45	1.57	1.56
		140	1.04	1.13	1.12
		184	0.91	0.99	0.98
		235	0.81	0.88	0.87
		f_K	14.7	13.6	13.7
	No 3	89	1.24	1.34	1.33
140		1.10	1.18	1.17	
184		1.07	1.15	1.15	
235		0.78	0.84	0.83	
f_K		11.6	10.9	10.9	
Hem-fir	Sel	89	1.19	1.28	1.27
		140	1.18	1.27	1.26
		184	1.07	1.15	1.14
		235	0.76	0.82	0.81
		f_K	24.4	22.7	22.8
	No 2	89	1.05	1.12	1.11
		140	1.21	1.29	1.27
		184	0.98	1.04	1.03
		235	0.95	1.01	1.00
	f_K	18.1	16.9	17.1	
	No 3	89	1.37	1.48	1.47
		140	1.06	1.14	1.13
184		0.98	1.06	1.05	
235		0.80	0.86	0.86	
f_K		14.7	13.6	13.7	

continued

(continued)

Table 6 Depth factors (K) obtained by expressing the Canadian test results as ratios of the species/grade characteristic stress values (f_K N/mm²)

Species	Grade	Depth mm	Equation (1)	Equation (3)	Equation (4)
Spruce-pine-fir	Sel	89	1.15	1.25	1.24
		140	1.11	1.20	1.20
		184	1.03	1.13	1.12
		235	0.82	0.89	0.89
		f_K	22.1	20.3	20.4
	No 1	89	1.33	1.47	1.48
		140	1.02	1.14	1.14
		184	0.89	0.98	0.99
		f_K	18.5	16.7	16.6
	No 2	89	1.24	1.34	1.33
		140	1.04	1.13	1.12
		184	0.98	1.06	1.05
235		0.94	1.02	1.01	
f_K		16.7	15.4	15.5	
No 3	89	1.35	1.46	1.44	
	140	1.06	1.14	1.13	
	184	0.79	0.85	0.84	
	235	0.98	1.06	1.05	
	f_K	12.7	11.8	11.9	

Table 7 Root mean square differences between depth factors obtained from the test results and from the general depth factor equations

Data source	Species	Grade	Root mean squares ($\times 10^2$)		
			Equation (1)	Equation (3)	Equation (4)
PRL	Redwood/white-wood	SS	1.51*	8.26	7.69
	Hem-fir	SS	4.97*	6.95	10.58
		Sel	7.03*	8.86	12.42
		No 2	3.44*	4.95	5.14
Spruce-pine-fir	SS	11.27	0.95*	3.89	
	Sel	9.98	0.67*	2.08	
	No 2	11.88	2.20*	4.76	
	British-grown Douglas fir	SS	1.98*	8.16	7.72
Canada	Douglas fir-larch	Sel	18.89	11.07	10.10*
		No 1	27.24	18.50	17.80*
		No 2	18.39	9.88*	11.47
		No 3	11.26	8.17	5.67*
	Hem-fir	Sel	12.16	11.17	7.81*
		No 2	8.34*	15.47	14.18
		No 3	14.62	6.10*	6.75
	Spruce-pine-fir	Sel	7.35	8.83	6.37*
		No 1	14.01	5.96*	8.85
		No 2	6.04	4.94*	7.12
		No 3	16.06	11.74*	14.35
	Mean values			10.86	8.04

*lowest root mean square value

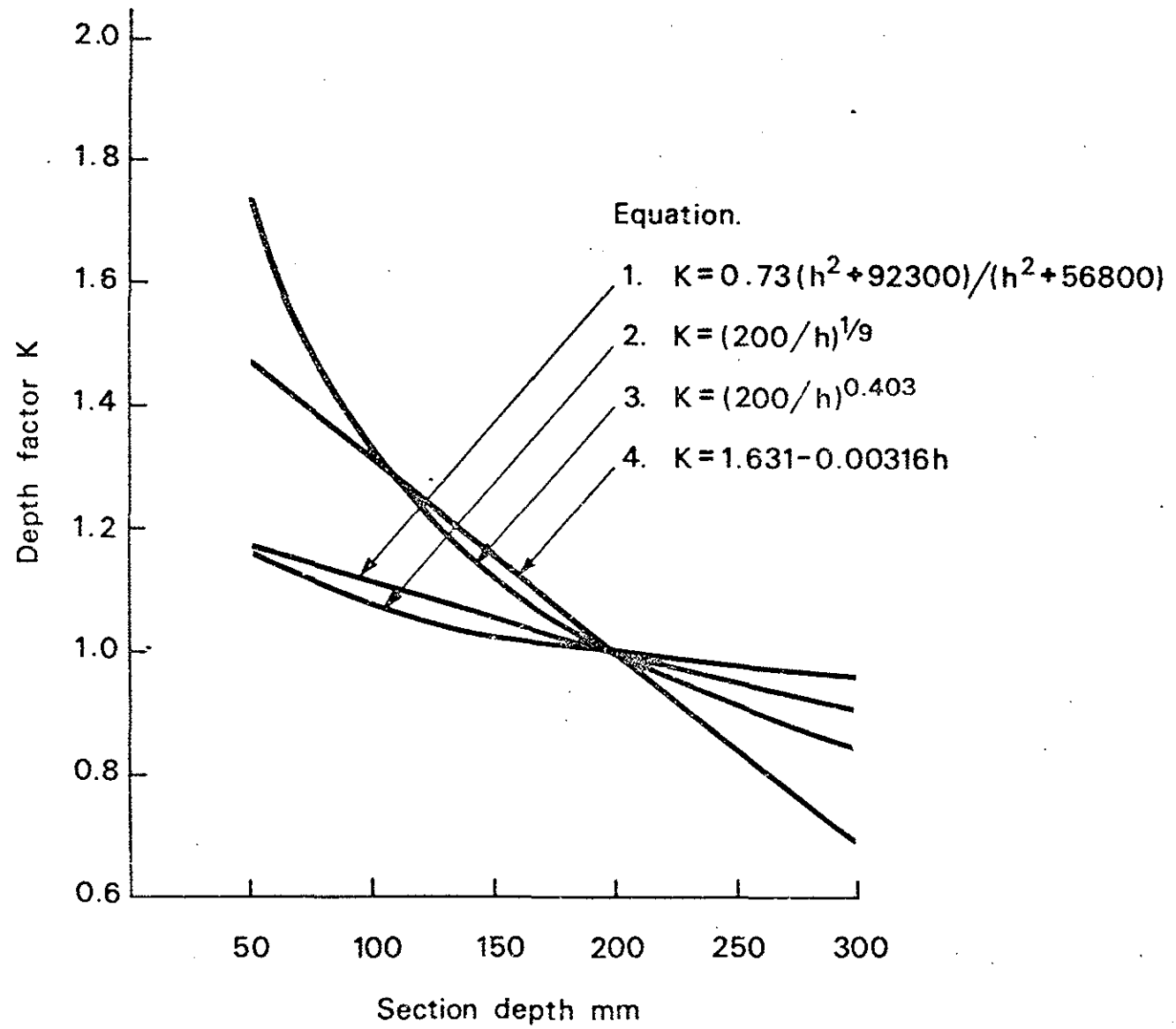

Fig.1. Effect of depth on bending stress.

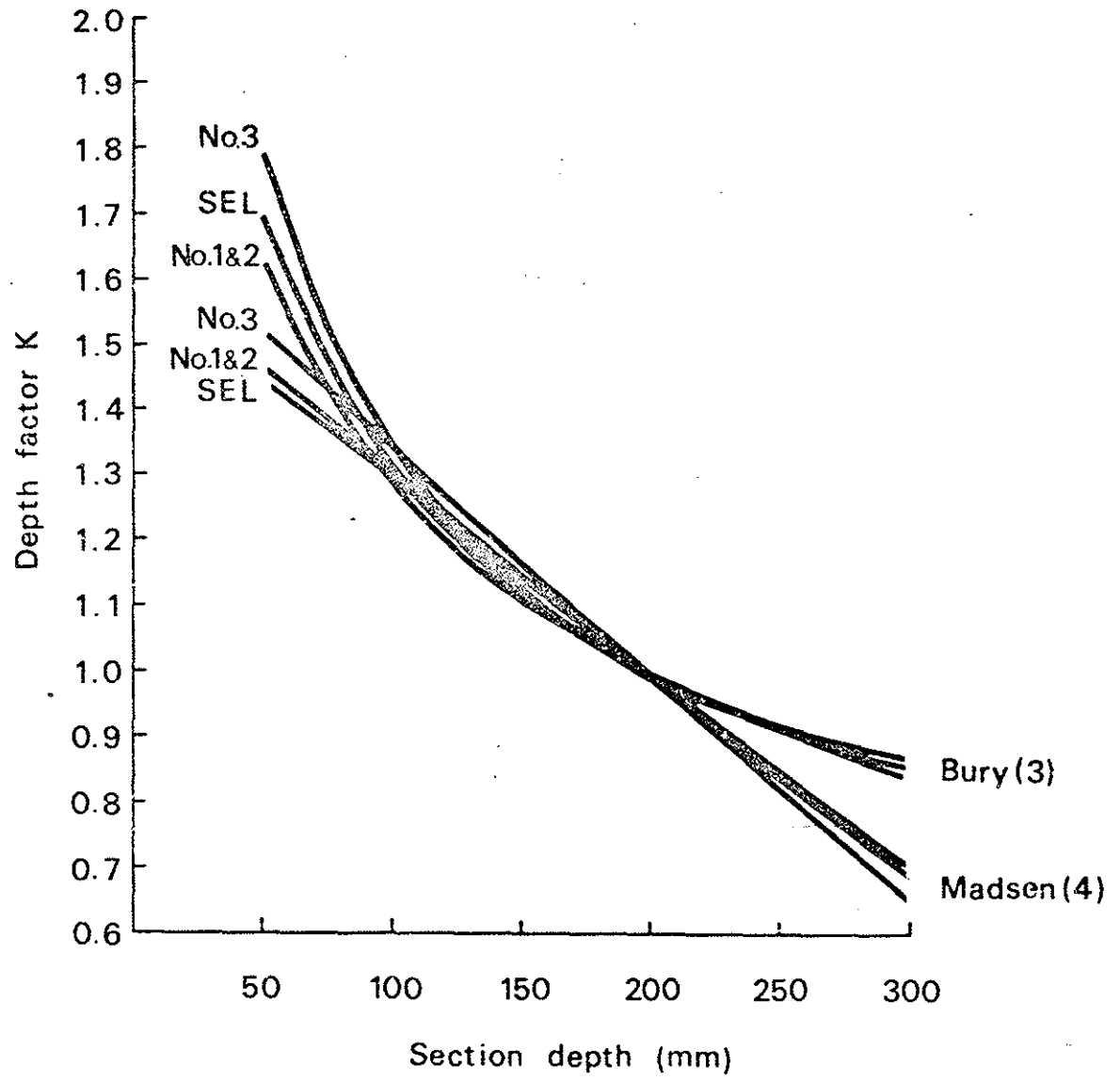

Fig.2. Comparison of grade equations.

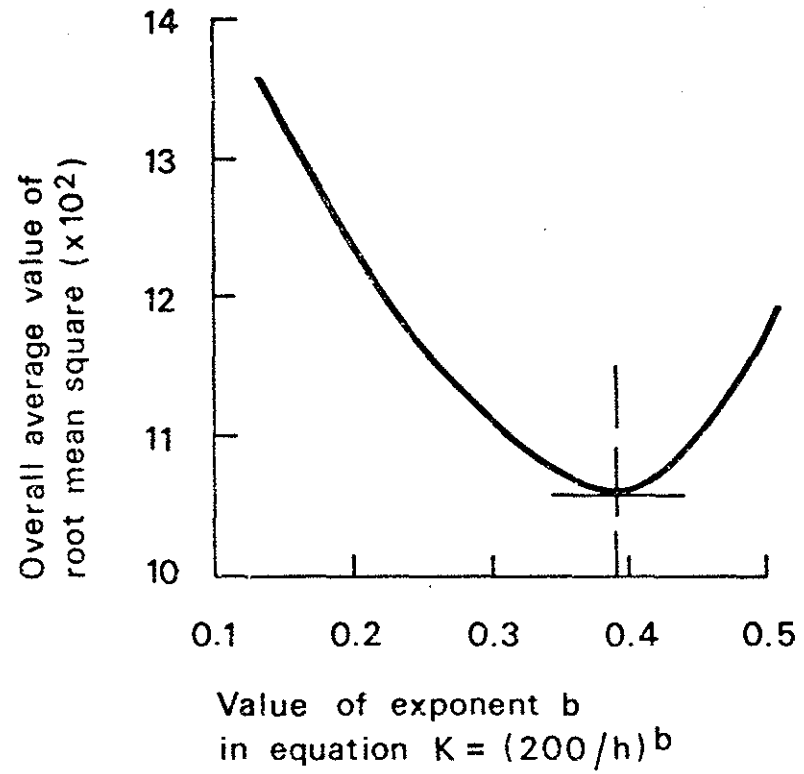

Fig.3. Effect of exponent b on value of root mean square difference between test and predicted values of depth factor.

INTERNATIONAL COUNCIL FOR BUILDING RESEARCH STUDIES AND DOCUMENTATION
WORKING COMMISSION W18 - TIMBER STRUCTURES

STRENGTH CLASSES
FOR INTERNATIONAL CODES

by

A R Fewell and J G Sunley

PRL / TRADA

United Kingdom

LILLEHAMMER

NORWAY

MAY/JUNE 1983

INTERNATIONAL COUNCIL FOR BUILDING RESEARCH STUDIES AND DOCUMENTATION
WORKING COMMISSION W18 - TIMBER STRUCTURES

STRENGTH CLASSES
FOR INTERNATIONAL CODES

by

A R Fewell and J G Sunley

PRL / TRADA

United Kingdom

LILLEHAMMER

NORWAY

MAY/JUNE 1983

INTERNATIONAL COUNCIL FOR BUILDING RESEARCH STUDIES AND DOCUMENTATION
WORKING COMMISSION W18 - TIMBER STRUCTURES

STRENGTH CLASSES
FOR INTERNATIONAL CODES

by

A R Fewell and J G Sunley

PRL / TRADA

United Kingdom

LILLEHAMMER

NORWAY

MAY/JUNE 1983

STRENGTH CLASSES FOR INTERNATIONAL CODES

by

A.R. Fewell and J.G. Sunley

INTRODUCTION

Structural timber can be stress graded by both visual and mechanical means. Whilst grading machines can be set to grade to any strength level within the range of a given species, visual grading rules cannot be finely adjusted and so will often result in different stresses for the same grade of different species. Any country, such as the UK, utilising many different species from different countries for structural applications is therefore faced with an array of alternative species/grade combinations with varying strength properties. The complexity caused by this wide variety of alternative species and grades has prompted the following criticisms in the UK for this system.

1. To make the most economical choice of species and grade a designer needs knowledge of the price and availability of the various alternatives. He is not always sufficiently well informed to make the best choice and even if it was the most economical choice at the time of design it may not be the most economical choice at the time of purchase.
2. It has been said that the complexity of species and grades inhibits the use of timber in structures designed by persons not regularly engaged in timber design.
3. A lot of time is frequently spent by suppliers and specifiers discussing alternative combinations of species and grade to those originally specified.
4. Most British plantation grown timber is not directly equivalent to grades of the same imported species and so finds it difficult to compete for a share of the market for structural timber.
5. The current combinations of grades, particularly for machine grading are not always the most suitable for the species being graded, yielding too many rejects or too few pieces within one grade.
6. It is difficult for new species/grade combinations to penetrate the structural timber market particularly when they may be only intermittently available.

7. Each time an existing design of timber structure is re-ordered it may be necessary to laboriously check and change the grades and species specified to allow for changes in their price and availability.

The means of overcoming these criticisms is seen in Australia, the UK (in the revised Code of Practice BS 5268 : Part 2) and by ISO TC/165 as a system of strength classes. It should be noted that the North American machine stress rated grades are also in effect strength classes.

A strength class system comprises a number of classes, each with its own set of strength properties, into which species/grade combinations of similar strength are allocated. Design calculations can be carried out using properties for a particular class and any combination of species and grade that meets that class can be used, allowing the full advantage of price and availability to be obtained. All strength class systems follow these general principles. The major differences are in the number of classes and the method of selecting strength property values for each class.

THE UK SYSTEM

In the UK strength class system shown in Table 1 there are nine classes. In fact classes SC6 to SC9 are for denser hardwoods and SC1 and SC2 are unlikely to be popular choices. This means that for softwoods a designer will usually make a choice between SC3, SC4 and SC5. The stress values shown in Table 1 are design stresses but a system could be devised using characteristic values. (Table 3 shows estimated characteristic bending stresses.) Table 2 shows the allocation to classes of the similar BS 4978 grades. BS 5268 also contains other tables allocating North American grades and hardwoods.

There are complications, for example a specifier may have to list certain species as unacceptable where fastener strength or durability is important, but it is expected that these complications will be minor.

A major advantage of strength classes for the operators of grading machines will be that machines can be set to grade any species exactly to a strength class boundary stress level. This overcomes the problem of inefficiency for some combinations of species and visual grades which have strengths above those values assigned to the classes to which they have been allocated. Grading machines can also be used to grade species into classes in which no visual grade of that species has been allocated and in which it would not otherwise be able to compete.

AN INTERNATIONAL SYSTEM

The foregoing statements and comments relate to a strength class system devised for a country using many different combinations of species and grade, mostly imported, and therefore subject to considerable variability of price and availability. Whilst this system could be applied to other regions in the Northern Hemisphere using similar species, its use internationally would have the following problems.

1. Any strength class system will contain combinations of species and grade which have higher strength than the class to which they are assigned. These differences need to be minimised if designers are to be encouraged to specify a strength class rather than a species and grade. A national strength class system can be tailored to suit the most common species and grades used in that country to minimise these differences, whereas an international system cannot.
2. The inefficiency caused by the above differences can only be reduced in an international system by increasing the number of classes, a solution which has its own disadvantages.
3. Grading is not always carried out in the country of origin of the timber. This can cause problems in identification which would affect the classification of particular species in different countries. For example the UK imports redwood/whitewood from many different countries and any grade of this species combination is assigned one set of strength properties which are obviously influenced by the weakest source. Thus the UK would assign a particular grade of redwood/whitewood to one class which might be thought too low by a country such as Sweden using only Swedish redwood/whitewood.
4. A country using very few species might even find strength classes a disadvantage.

At this stage efforts should be aimed at unifying standards on stress grading rules and strength class systems should be devised nationally or regionally to include the international grades of various species. It might not be in the interest of all countries to adopt the same strength class system.

TABLE 1. GRADE STRESSES AND MODULI OF ELASTICITY FOR STRENGTH CLASSES: FOR THE DRY EXPOSURE CONDITION

Strength class	Bending parallel to grain (N/mm ²)	Tension parallel to grain (see note 3) (N/mm ²)	Compression parallel to grain (N/mm ²)	Compression perpendicular to grain (see note 1)		Shear parallel to grain (N/mm ²)	Modulus of elasticity		Approximate density (see note 4) (kg/m ³)
				Grade			Mean	Minimum	
				(N/mm ²)	(N/mm ²)		(N/mm ²)	(N/mm ²)	
SC1	2.8	2.2	3.5	2.1	1.2	0.46	6800	4500	540
SC2	4.1	2.5	5.3	2.1	1.6	0.66	8000	5000	540
SC3	5.3	3.2	6.8	2.2	1.7	0.67	8800	5800	540
SC4	7.5	4.5	7.9	2.4	1.9	0.71	9900	6600	590
SC5	10.0	6.0	8.7	2.8	2.4	1.00	10700	7100	590/760
SC6 (see note 2)	12.5	7.5	12.5	3.8	2.8	1.50	14100	11800	840
SC7 (see note 2)	15.0	9.0	14.5	4.4	3.3	1.75	16200	13600	960
SC8 (see note 2)	17.5	10.5	16.5	5.2	3.9	2.00	18700	15600	1080
SC9 (see note 2)	20.5	12.3	19.5	6.1	4.6	2.25	21600	18000	1200

NOTE 1. When the specification specifically prohibits wane at bearing areas the higher values of compression perpendicular to the grain stress may be used, otherwise the lower values apply.

NOTE 2. Classes SC6, SC7, SC8 and SC9 will usually comprise the denser hardwoods.

NOTE 3. Note the Light Framing, Stud, Structural Light Framing No. 3 and Joist and Plank No. 3 grades should not be used for tension members.

NOTE 4. Since many species may contribute to any of the strength classes, the values of density given in this table may be considered only crude approximations. When a more accurate value is required it may be necessary to identify individual species and utilize the values given in appendix A. The higher value for SC5 is more appropriate for hardwoods.

TABLE 2. SOFTWOODS WHICH SATISFY THE REQUIREMENTS FOR STRENGTH CLASSES: GRADED TO BS 4978

Standard name	Strength class				
	SC1	SC2	SC3	SC4	SC5*
<u>Imported</u>					
Parana Pine			GS	SS	
Pitch Pine (Caribbean)			GS		SS
Redwood			GS/M50	SS	M75
Whitewood			GS/M50	SS	M75
Western Red Cedar	GS	SS			
Douglas Fir-Larch (Canada)			GS	SS	
Douglas Fir-Larch (USA)			GS	SS	
Hem-Fir (Canada)			GS/M50	SS	M75
Hem-Fir (USA) ‡			GS	SS	
Spruce-Pine-Fir (Canada) †			GS/M50	SS/M75	
Western Whitewoods (USA) †	GS		SS		
Southern Pine (USA)			GS	SS	
<u>British grown</u>					
Douglas Fir		GS	M50/SS		M75
Larch			GS	SS	
Scots Pine			GS/M50	SS	M75
Corsican Pine		GS	M50	SS	M75
European Spruce †	GS	M50/SS	M75		
Sitka Spruce †	GS	M50/SS	M75		

*All softwoods classified as strength class SC5, except Pitch Pine and Southern Pine (USA) should use the fastener loads tabulated for strength classes SC3 and SC4.

†All grades of British grown Sitka spruce, British grown European spruce and Western Whitewoods (USA) should use the fastener loads tabulated for strength classes SC1 and SC2.

‡For grades of Hem-Fir (USA) and Spruce-Pine-Fir (Canada) in strength classes other than SC1 and SC2 the values of lateral load perpendicular to the grain for coach screws, bolts and timber connectors should be multiplied by the joint/class modification factor K_{42} which has the value 0.9.

Machine grades MGS and MSS may be substituted for the GS and SS grades respectively.

A species/grade combination from a higher strength class (see table 8) may be used where a lower strength class is specified.

The S6, S8, MS6 and MS8 grades of the ECE 'Recommended Standard for Stress Grading of Coniferous Sawn Timber' (1982) may be substituted for GS, SS, MGS and MSS respectively.

TABLE 3.

ESTIMATED CHARACTERISTIC BENDING STRESSES

Strength Class	Bending Stress N/mm ²	Equivalent Characteristic Stress (see Note 2) N/mm ²
SC1	2.8	5.9
SC2	4.1	8.6
SC3	5.3	11.1
SC4	7.5	15.7
SC5	10.0	21.0
SC6	12.5	26.2
SC7	15.0	31.5
SC8	17.5	36.7
SC9	20.5	43.0

NOTES

1. BS 5268 permits all bending and tension stresses for members whose depth or width is less than 300mm to be increased by a factor $K = (300/h)^{0.11}$.
2. The characteristic stress values are for 300mm depth and are predicted minimum lower 5th percentiles. That is to say they are the weighted mean of 5th percentiles from test samples multiplied by a safety factor. Because machine grades and visual grades have different safety factors the weighted mean 5th percentiles are different for the two methods of grading.

If the characteristic values quoted above were for visual grades only with no safety factor and referred to a 100mm depth the values could be multiplied by a factor of approximately 1.60.

INTERNATIONAL COUNCIL FOR BUILDING RESEARCH STUDIES AND DOCUMENTATION
WORKING COMMISSION W18 - TIMBER STRUCTURES

LOAD-CARRYING
CAPACITY OF DOWELS

by

E. Gehri

Applied Statics and Steel Structures
Swiss Federal Institute of Technology
Switzerland

LILLEHAMMER
NORWAY
MAY/JUNE 1983

INTERNATIONAL COUNCIL FOR BUILDING RESEARCH STUDIES AND DOCUMENTATION
WORKING COMMISSION W18 - TIMBER STRUCTURES

LOAD-CARRYING
CAPACITY OF DOWELS

by

E. Gehri

Applied Statics and Steel Structures
Swiss Federal Institute of Technology
Switzerland

LILLEHAMMER
NORWAY
MAY/JUNE 1983

INTERNATIONAL COUNCIL FOR BUILDING RESEARCH STUDIES AND DOCUMENTATION
WORKING COMMISSION W18 - TIMBER STRUCTURES

LOAD-CARRYING
CAPACITY OF DOWELS

by

E Gehri

Applied Statics and Steel Structures
Swiss Federal Institute of Technology
Switzerland

LILLEHAMMER
NORWAY
MAY/JUNE 1983

Load-carrying capacity of dowels

1. INTRODUCTION

In connection with the new swiss timber code [1] a few tests on timber-to-timber joints, mainly connected with dowels, were performed. Since the new code gives for these connections smaller values than those allowed by the german code DIN 1052 [2] or by the CIB-Structural Timber Design Code [3], the main purpose of the tests was to obtain an upper limit of the load-carrying capacity. Therefore glued laminated timber was used. Due to the greater uniformity of glulam, although smaller scatter of the test values could be expected.

The tests described here were performed with the same joint configuration, the only parameter being the thickness of the timber elements. For more detailed information see [4].

2. DESCRIPTION OF THE SPECIMENS

Fourteen tests were performed, with 5 different member thicknesses. The joints were built up symmetrically and tested in tension. The configuration is given in Figure 1 and the thickness of the timber elements in Table 1.

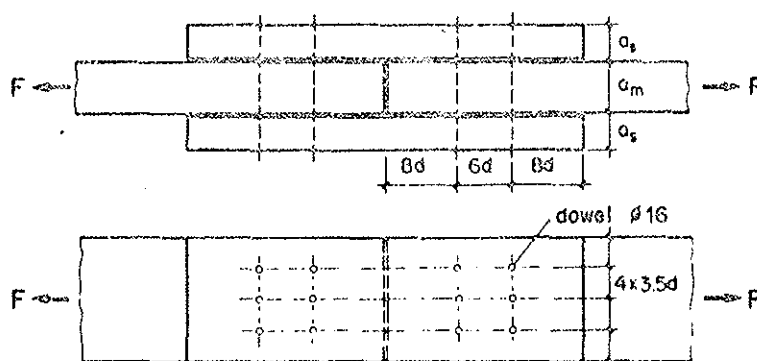

Fig. 1: Configuration of the specimens with 6 dowels ϕ 16 mm

Table 1: Thickness of the timber elements

λ_{k1}	1.5	3	4.5	6	7.5
a_m	1.5 d	3 d	4.5 d	6 d	7.5 d
a_s	1 d	2 d	3 d	4 d	5 d

The timber splices have each 2/3 of the thickness of the main member.

3. MATERIAL PROPERTIES

For the main member and for the splices glued laminated spruce (*picea abies* Karst.) was used. The relative density was of $\rho = 0.46 \pm 0.02 \text{ t/m}^3$, the compressive strength was about 45 N/mm^2 for a moisture content of 11 %.

The dowels were made of steel Fe 360 with a yield point of 262 N/mm^2 and an ultimate strength of 404 N/mm^2 .

4. TEST RESULTS

The results of the 14 tests are shown in Table 2. The scatter was low. The final failure occurred generally in the side member through splitting of the wood starting in the outer row. For $\lambda > 3$ failure was always accompanied by a pronounced plastic bending of the dowels.

Table 2: Ultimate load of the joint in kN

λ_m	1.5	3	4.5	6	7.5
Test 1	77	123	140	159	170
Test 2	66	126	133	151	163
Test 3	--	119	136	153	167
middle values	72	123	136	154	167

5. LOAD-CARRYING CAPACITY BY DIFFERENT CODES

5.1 Swiss code

The swiss code is based on allowable stresses. Per shear plane of a three member joint with $\lambda_m = 6$ and $\lambda_a = 4$ the allowable value parallel to grain and for long term loading is given as

$$F_{||} = 44 \cdot d^{1,7} \quad [F \text{ in Newton for } d \text{ in mm}]$$

For a dowel with $\phi 16 \text{ mm}$ the allowable value is equal to 4.90 kN. For smaller values of slenderness the allowable loads must be reduced in proportion; for higher values no increase is foreseen.

The minimum distances observed in the test specimens are those prescribed by the swiss code.

5.2 German code DIN 1052

The german code allows lower minimum distances between dowels (parallel to grain $5 d$ and perpendicular to grain $3 d$) and an end distance of $6 d$. The allowed loads are nevertheless higher, especially for larger diameters of the dowels.

5.3 CIB-Code

With density of the wood $\rho = 0.46 \text{ t/m}^3$ and a yield strength of the dowels of $f_y = 262 \text{ N/mm}^2$ we obtain the load-carrying capacity in N per shear plane to

$$F_{||} = \text{min. value of } \begin{cases} 20.1 \cdot \lambda \cdot d^2 \\ 66.4 \cdot d^2 \end{cases} + \lambda_{lim} = 3.3$$

Considering the higher yield strength and the larger required minimum distances, the above values have to be multiplied by 0.82.

6. COMPARISON TEST-CODE VALUES

A comparison between the ultimate load capacity determined with the CIB-Code and the test results is shown in Figure 2.

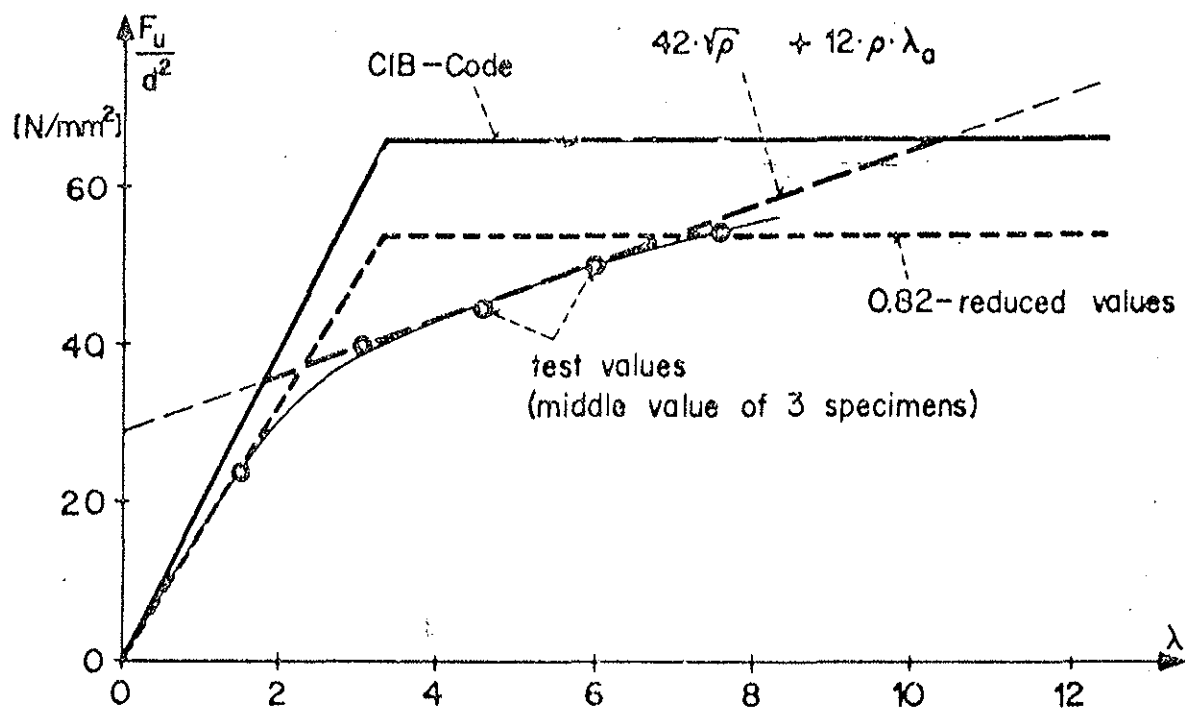
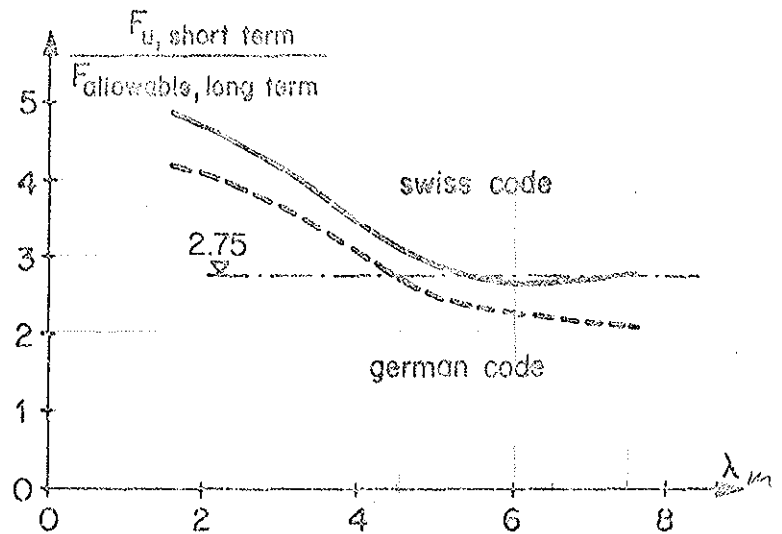

Fig. 2: Comparison CIB-Code and test results

Considerable differences can be noted for the range $3 < \lambda < 6$, even when taking the reduced values (due to the shorter minimum distances). A good approach can only be achieved by introducing a third condition (dotted line in Figure 2) as it was originally proposed by LARSEN [5] for the CIB-Code.

In Figure 3 the relation between ultimate loads (short term) and the allowable values (long term) is shown for the swiss and german code. As a result we found a certain inconsistency of the level of safety. With short dowels ($\lambda_m \leq 3$) higher factors are obtained.

Fig. 3:
Relation between ultimate
load and allowable values



7. CONCLUSIONS

Actual codes do not take in account the bilinear relationship between the ultimate load and the slenderness of the dowel. Moreover the CIB-Structural Timber Design Code, as formulated now, gives too high values. A good agreement can be attained by introducing a third condition for the ultimate load, as stated in previous proposals. Besides the influence of a shorter minimum distance between dowels in a row (6 d instead of 7 d) has been overestimated.

LITERATURE

- [1] Norm SIA 164 (1981) - Holzbau. Schweiz. Ingenieur- und Architekten-Verein.
- [2] DIN 1052, Blatt 1 - Holzbauwerke, Berechnung und Ausführung. Ausgabe Oktober 1969.
- [3] CIB-Structural Timber Design Code. Fifth edition, August 1980.
- [4] GEHRI, E. / FONTANA M.: Betrachtungen zum Tragverhalten von Passbolzen in Holz-Holz-Verbindungen. Baustatik und Stahlbau, Publikation Nr. 83-1. Eidg. Techn. Hochschule Zürich 1983.
- [5] LARSEN, H.J.: Design of bolted joints. CIB-W18/12-7-2, Bordeaux-October 1979.

INTERNATIONAL COUNCIL FOR BUILDING RESEARCH STUDIES AND DOCUMENTATION
WORKING COMMISSION W18 - TIMBER STRUCTURES

BOLTED TIMBER JOINTS:
A LITERATURE SURVEY

by

N Harding

Building Research Association of New Zealand
New Zealand

LILLEHAMMER
NORWAY
MAY/JUNE 1983

INTERNATIONAL COUNCIL FOR BUILDING RESEARCH STUDIES AND DOCUMENTATION
WORKING COMMISSION W18 - TIMBER STRUCTURES

BOLTED TIMBER JOINTS:
A LITERATURE SURVEY

by

N Harding

Building Research Association of New Zealand
New Zealand

LILLEHAMMER

NORWAY

MAY/JUNE 1983

INTERNATIONAL COUNCIL FOR BUILDING RESEARCH STUDIES AND DOCUMENTATION

WORKING COMMISSION W18 - TIMBER STRUCTURES

BOLTED TIMBER JOINTS:
A LITERATURE SURVEY

by

N Harding

Building Research Association of New Zealand

New Zealand

LILLEHAMMER

NORWAY

MAY/JUNE 1983

BOLTED TIMBER JOINTS: A
LITERATURE SURVEY

RESEARCH REPORT R-.

N. Harding

REFERENCE

Harding, N. 1982. Bolted Timber Joints: A Literature Survey. Building Research Association of New Zealand. Research Report R-. Judgeford.

KEYWORDS

From Construction Industry Thesaurus, BRANZ edition: Bolts; Bibliographies; Codes of practice; Joints; Loads; New Zealand; Shear; Standards; Strength; Structural design; Surveys; Test procedures; Timber; World.

ABSTRACT

A review of the literature has been carried out to obtain information of direct relevance to a proposed test programme with the objective of preparing design information on bolted and coach-screwed timber joints loaded in shear in circumstances not adequately covered by currently available codes of practice and timber design handbooks.

Aspects covered by the review are: Connections which have bolt edge and end distances less than the minima currently specified in NZS 3603:1981 (Code of practice for timber design); connections which have smaller washers than those currently specified in NZS 3603; ultimate strength design; load/deflection relationships; test specimen variables; implications for earthquake loading.

PREFACE

This literature survey is the first part of a research programme to be carried out by BRANZ to prepare design information on bolted and coach-screwed timber connections, loaded in shear, in applications which are not adequately covered by currently available codes of practice and timber design handbooks.

This report is intended for other workers in the field of timber engineering research.

CONTENTS

PAGE

INTRODUCTION

DISCUSSION

Connections which have bolt end and edge distances less than the minima currently specified in NZS 3603: 1981 Code of practice for timber design.

Connections which have smaller washers than those currently specified in NZS 3603.

Ultimate Strength Design-Load/Deflection Relationships.

Test Specimen Variables

Earthquake Loading

CONCLUSIONS

FOOTNOTES

REFERENCES

Standard and Codes

General

BIBLIOGRAPHY

Standards and Codes

General

BOLTED TIMBER JOINTS : A

LITERATURE SURVEY

INTRODUCTION.

Currently available design information on bolted timber joints loaded in shear concentrates on specifying conditions under which a maximum joint load can be developed. In practice these conditions are often highly inconvenient to fulfil and many bolted connections are made which of necessity violate some code rules. Though these connections obviously do have some strength, failure to comply with the rules means a code allowable joint load of zero.

This research programme was conceived with the objective of preparing design information on bolted and coach-screwed connections loaded in shear in circumstances not adequately covered by currently available codes of practice and timber design handbooks.

The areas chosen for investigation concern connections which have end and edge distances less than the minima currently specified and those having smaller washers than prescribed. These were considered areas in which code violations most commonly occurred.

The test criteria governing the design of timber structures are deflection and strength. With regard to the first, the load/deflection data for bolted joints required by designers are not available. With the second criterion, although the bolt loads given in NZS 3603 have been derived from ultimate load tests, no indication is given of the ultimate loads of the bolted connections described, or their mode of failure.

Information on these design criteria will also be provided by this research for joints constructed in accordance with code provisions together with details of the comparative behaviour of such 'modifications' to these joints as may possibly be necessitated by practical considerations.

In general, the provisions of the pertinent New Zealand building codes, together with a

large number of their overseas equivalents, indicate a wide acceptance of design criteria based upon experimental work carried out at the U.S. Forest Products Laboratory during the 1930s and early 1940s. Research carried out in Europe, notably in Scandinavia and the Netherlands during the early post-war years, also appears to provide a basis for the formulation of New Zealand and overseas code provisions.

A survey of literature relevant to the proposed research was carried out prior to formulation of a definitive test programme and experimental design. Subjects of interest included test and other background data used in preparation of New Zealand and overseas code provisions.

Further investigation was carried out into published data on past research from varied sources in an attempt to procure information of direct relevance to the proposed test programme, both as a means of evaluating applicable test procedures and to avoid unnecessary duplication of earlier research work. Information relevant to the various aspects of the proposed research is summarised under the appropriate headings in this report.

This report on the literature survey represents an initial stage of the proposed research programme and is intended to provide a basis for discussion and suggestions as to the subsequent emphasis of the research. The main conclusion is confirmation of the suspicion that there was insufficient detailed and replicated information existing on the proposed subjects for research.

DISCUSSION

Connections which have bolt edge and end distances less than the minima currently specified in NZS 3603 : 1981 Code of practice for timber design.

The original experimental work on the strength of bolted timber connections was carried out at the U.S. Forest Products Laboratory (Trayer, 1932) and is cited in much of the other reference material. No evidence of prior research has been found apart from a study, again at Forest Products Laboratory, of aircraft bolts (Trayer, 1928). In Trayer's own words; "... no extensive series of actual strength tests of ordinary bolted timber joints from which safe working values might be selected with assurance has heretofore been made." This would appear to be true.

Trayer's recommendations have been incorporated, with very little modification, into the relevant building codes of Australia (A.S. 1720-1975; S.A.A. Timber Engineering Code), Canada (Canadian Wood Construction WJ4 1977 Connectors and Supports), New Zealand (NZS 3603:1981), the United Kingdom (C.P. 112 : Part 2 : 1971 The Structural Use of Timber) and the U.S.A. (National Design Specification for Stress-Grade Lumber and its Fastenings 1971). It seems quite likely that many other countries will have incorporated at least some of Trayer's recommendations into their own relevant codes of practice. (Booth and Reece, 1967).

In Australia, modifications were made for the use of green hardwoods, with their inherently high incidence of splitting during drying. The working loads for the relatively low-density, North American timber species were extrapolated to apply to the considerably higher strength Australian timbers. These modifications, as specified in AS 1720-1975, were subsequently adopted by New Zealand for incorporation in NZS : 3603. Previously the building codes of both countries corresponded more closely to Trayer's figures.

A comparison between Trayer's figures for minimum end and edge distances and those minima specified in the publications cited above is given below:

Trayer	Building Code
<u>Load parallel to grain</u>	
End distance	
7D Softwoods (loaded end)	7D (WJ4 1977, CP 112, NDS 1971) 8D (AS 1720, NZS 3603)
5D Hardwoods (loaded end)	5D (WJ4 1977, NDS 1971) No proviso for hardwoods in other codes.
4D (unloaded end)	4D (WJ4 1977, CP. 112, NDS 1971) 5D (AS 1720, NZS 3603)
Edge distance	
1.5 D "usual practice requies..."	2D (AS 1720, NZS 3603)

half the distance between bolt rows"

N.B. Trayer specifies a normal minimum 4D spacing between rows of bolts. 1.5D (J4 1977, CP 112, NDS 1971)

Load perpendicular to grain

End distance

Not specified

4D (WJ4 1977, CP 112, NDS 1971)

Not specified (AS 1720, NZS 3603)

Edge distances

4D (loaded edge)

4D (WJ4 1977, CP.112, NDS 1971, AS 1720, NZS 3603)

"...relatively unimportant"

(unloaded edge)

2D (NZS 3603)

1.5D (WJ4 1977, NDS 1971)

Not specified (AS 1720, CP 112)

Trayer refers to tests carried out to determine the proper margin and spacing of bolted joints. However, no data is quoted from the results obtained in support of recommended minimum distances - which presumably included some form of safety factor.

Although outside the scope of this investigation, it is of interest to note that other recommendations included in Trayer's report concerning the undesirability of using staggered-bolt joints, loaded parallel to the grain, have not been confirmed in subsequent research by various organizations. (Kunesh and Johnson, 1968; Wilkinson, 1980). Kunesh and Johnson's results indicated that the performance and efficiency of such joints equalled or surpassed those of joints with bolts in regular patterns. (i.e. placed opposite each other in uniformly-spaced rows, parallel to the direction of the applied load.)

In the introduction to their report Kunesh and Johnson describe their work as part of a wider investigation, by the United States Department of Agriculture, Forest Research Laboratory, of factors relevant to the performance of bolted timber joints. As Trayer's recommendations appeared in an earlier publication by this organization it is interesting

to find these factors, which include the effect of end distance on joint strength, referred to by Kunesh and Johnson as, "not studied intensively at earlier times," with all that this implies regarding the scope of Trayer's tests.

One further reference of note was a tentative summary of tests on bolted plywood joints. These tests, carried out at the University of Washington in 1951 for the now defunct Douglas Fir Plywood Association, indicated that assumption of a load reduction in direct proportion to the end or edge distance reduction was highly conservative, for reductions of up to 50% of the minimum end and edge distances required to develop full timber bearing strength. Further work was to be carried out to investigate the relationship between loads and reduced end and edge margins. No further reference to this work could be obtained from any source and the University of Washington was unable to confirm that such research had in fact been carried out.

Connections which have smaller washers than those currently specified in NZS 3603.

From available data (Noren, 1948, 1949, 1951; Trayer, 1928, 1932; Wilkinson, 1971) it is clear that washer dimensions have been principally designed for applications in which bolts are acted upon by a direct tensile force (i.e. anchor fixings). This is logical as this situation would represent a 'worst case' of loading for the joint and by increasing the bearing area beneath the bolt head most of the full tensile strength of the bolt may be utilised before failure of the joint occurs due to embedment of the washer and bolt head into the timber.

In the case of coach-screws, additional criteria governing the dimensions of hole sizes for both shank and threaded portion and depth of penetration into the main member are strictly specified (NZS 3603, AS 1720, CP 112, WJ4 1977, NDS 1971) in order that the maximum resistance to withdrawal of the joint should approximate the maximum tensile strength of the coach-screw. (Newlin and Gahagan, 1938).

As the tensile strength of a bolt and the compressive strength of timber are both functions of area one may expect a fairly constant relationship to exist between the bearing area of washers and the cross-sectional area of the maximum bolt size permitted under code provisions for use with each respective washer size, equivalent to the relationship between these strengths. In a 'worst case' situation with a weak timber

(compressive strength 2.5-3.0 N/mm²) this relationship would be around 10 or 12. Considering the provisions of NZS 3603:

Max bolt diameter	8 mm	12 mm	20 mm	20 mm plus
Min washer size	25 x 25 mm	50 x 50 mm	65 x 65 mm	75 x 75 mm
Washer thickness	1.5 mm	3 mm	5 mm	8 mm
Bolt cross-sec area (A)	50 mm ²	110 mm ²	310 mm ²	-
Washer bearing area (B)	550 mm ²	2300 mm ²	3700 mm ²	5500 mm ²
B/A	11	21	12	*

*B/A = 11 for bolt diameter 24 mm

For bolts of 8 mm and 20 mm diameter the relationship between bolt cross sectional area and washer bearing area is of the order expected. The washer specified for use with 12 mm bolts (and 10 mm) appears somewhat oversized and a washer 35-40 mm square would seem adequate.

Of interest are the results of an investigation carried out into the lateral bearing strength of wood under the embedment loading of fasteners (Wilkinson, 1971). These include a maximum load of around 21 KN achieved during an embedment test on Douglas Fir, using a 19 mm dia. bolt with a washer bearing area of 1497 mm². The fastener bearing area was thus very similar to that of a 40 x 40 mm square washer with a hole size intended for bolts of 8-12 mm dia. The failure of this joint, due to embedment of the washer, occurred at a loading of similar order to the expected maximum tensile strength of a 12 mm steel bolt and is further indication of the adequacy of washers somewhat smaller than specified by NZS 3603 to provide embedment resistance for fastener heads, insofar as the direct tensile component of bolt load is concerned, for joints using 12 mm bolts.

The function of washers in joints under lateral loading is more problematical in the load/deflection relationship of a bolted joint. Two values are of particular interest: the proportional limit load, and the yield point load. The relationship of the former to the chosen safe working load is the factor of safety against creep. The ratio of the yield point load to the safe working load gives an indication of the joints safety against short

term load.

Available data (Noren, 1948, 1949, 1951; Vermeyden, 1980) indicate that the friction forces induced by bending of the bolt under lateral loading are highly dependent upon the size of the fastener head and have a considerable influence on the load/deflection characteristics of bolted joints with low slenderness values. As the slenderness value (i.e. the ratio of the member thickness to bolt diameter) increases this effect assumes less importance as shown below:

Slenderness	Washer	P_p (kN)	P_F (kN)	P_{max} (kN)
1.83	None	2.5	4.6	5.4
	40 x 40 x4 mm	3.2	11.3	14.1
	90 x 90 x10 mm	4.3	13.2	27.9
3.66	None	3.8	8.3	9.9
	40 x 40 x 4 mm	4.6	12.2	22.3
	90 x 90 x 10 mm	4.9	13.7	35.8
7.28	None	5.7	12.0	13.7
	90 x 90 x 10 mm	5.8	12.7	29.0

12 mm bolts in single shear parallel to grain. (Noren, 1951).

P_p = Load at proportional limit (i.e. the point at which joint slip ceases to be proportional to the load).

P_F = Load at yield point (i.e. the point at which joint slip increases rapidly with each small load increment).

For purposes of comparison, Noren assumed P_p and P_F to occur at deflections of 1 mm and 10 mm respectively.

If either the proportional limit load or the yield point load are used as the criterion for specifying the safe working load of a bolted joint, loaded parallel to the grain, at a slenderness value of 3.66 the 40 mm washer offers a performance almost equal to the large, 90 mm washer. At a slenderness value of 7.28 the use of a washer appears irrelevant. The larger washers do provide a greater factor of safety for maximum load, however. Noren describes maximum load as a "typical laboratory value" strongly dependent upon rate of loading and suggests that the yield point may in practice be equated with failure load.

This conforms to the provisions of AS 1649-1974 (Methods for the determination of basic working loads for metal fasteners for timber) in which the 'maximum' lateral load for a dowel type timber connector from which the basic working loads are calculated, is specified as the load giving a joint deflection of 12.5 mm under the prescribed test conditions.

Tests carried out on joints in single shear loaded perpendicular to the grain have exhibited a similar pattern of behaviour. (Noren, 1948, 1949, 1951).

Joints in double shear are much less sensitive to the effects of washer size than joints of similar slenderness ratio in single shear. The maximum load attainable by these joints is also virtually unaffected by washer size beyond slenderness ratios of about 4. (Noren, 1949, 1951; Vermeyden, 1980).

Ultimate Strength Design - Load/Deflection relationships.

Numerous analytical models (various authors, see 1) exist to predict the behaviour of timber joints with dowel type connectors. Whilst differing widely in form all provide comparable results and are based generally upon data from tests carried out up to deflections of 10-15 mm. The maximum loads obtained by Noren and cited earlier were attained only after deflections of the order of 20-30 mm and were in fact largely due to the friction induced by this large deformation.

The methods of test have evolved from obscure origins together with ways of assessing the values to be put upon various criteria affecting the results. The remaining experimental evidence in their support appears to be that structures designed according to the building codes resultant from such testing have in general remained standing.

Considering AS 1649 which has been adopted by New Zealand with slight modification as the basis for fastener loads not given in NZS 3603, two methods are cited for calculating load per fastener in laterally loaded joints, one based on the load at a given slip and the other on maximum load, the smaller value obtained being used.

A designer can thus never know which of these criteria he must use regarding basic working loads. It would perhaps be better to consider joint strength and joint deformation separately. Knowledge of the ultimate strength of timber joints is particularly important in areas subject to earthquake loads where design to prevent a particular collapse mode of a structure may be necessary.

The results of Noren's research into the influence of washer size are of great interest here as they indicate that while the size of the washer may have relatively little effect on joint performance (at slenderness values greater than 4) under any normal loading condition, the manner of failure under gross overloading may be greatly modified by the use of adequate washers. Maximum loads for joints in single shear equal to those attained by double-sheared joints, albeit at deflections in excess of 30 mm, were reached and indications were that with adequate washers such joints would fail by 'subsidence' rather than 'collapse' (i.e. a ductile rather than a brittle failure) with possible advantageous consequences for the inhabitants of buildings featuring such joints.

In early work (Trayer, 1932) the proportional limit load was chosen as a basis for assessing the working load of a bolted timber joint. This was done on the grounds that it was more reliably predicted from the compressive strength of the wood in bearing under the bolt and from the yield moment of the bolt itself than the maximum load on which other factors such as friction and splitting have their effect. The size of the proportional limit load is dependent on how rapidly the load is applied. At its lowest value this load lies at the creep limit. Trayer chose a loading rate of 0.66 mm/min in what appears to be an attempt to achieve a 'worst-case' situation by applying the load as slowly as possible. Subsequent research (various authors, see 2) has tended towards using a rate of around 1.0 mm/min presumably in an effort to attain a convenient time of 1 minute to reach proportional limit load. No extensive research into the effects of loading rate seems to have been carried out with regard to bolted joints. Testing of nailed timber joints subjected to lateral loads at a variety of strain rates ranging from 0.25 to 12.7 mm/min indicates no significant variation in the load/deformation curve or

the ultimate load capacity of such joints. (Hall and March 1964). Vibrational loading tests carried out on similar nailed joints together with some bolted joints (Wilkinson, 1976), indicated that joint stiffness increased considerably under such loading as compared to static loading. These tests were carried out at levels of load, frequency and acceleration typical of earthquakes, based on available seismograph records. Apparent loading rates (defined by Wilkinson as displacement divided by the time for one half cycle of loading) during vibrational loading varied from 10 to 38 mm/min, considerably in excess of those used by Hall and March.

Test Specimen Variables

The behaviour and strength of bolted timber joints are influenced by too many factors for all combinations to have been adequately covered in test. It would probably not be feasible to do so. While the factors under investigation may have differed and researchers have not always agreed in their conclusions, several aspects have been common to almost all cases and in these at least there is tacit agreement on their importance.

- a. Whichever factor was under investigation, single bolt joints were also constructed as 'controls' and tested under similar conditions to the remaining specimens. These were generally two-member joints in single shear as are used in NZS 3603 to define basic working loads. (various authors, see 3). In some cases, where the behaviour of multi-member joints was of concern, three-member joints in double shear were used as controls. (various authors, see 4).
- b. Joints were constructed for tests both parallel and perpendicular to the grain unless a specific situation was under review and for which one of these directions could be discounted. Hankinsons' formula was considered applicable for all angles in between. (various authors, see 3 and 4).
- c. Specific gravity tests were often carried out rather than assuming a nominal species value from tables. Timber crushing strengths were generally assessed for investigations into more 'basic' factors. (various authors, see 5).

Tensile and bending tests of bolts were carried out when these were unknown quantities or when significant variation in the quality of the bolts was suspect. (various authors, see 6).

- d. Most sources favoured a uniform loading rate of approximately 1 mm/min. (various authors, see 7). (Mack, 1981) used a rate of 2 mm/min and (McLain, 1975) a rate of 2.54 mm/min, A.S. 1649 specifies a rate of 1.25 mm/min. In some cases an initial small loading was applied to take up slack in the joint. More complicated arrangements utilizing loading to failure in increments, after each of which the joint was either wholly or partially unloaded or a loading pause of 30 secs to 1 minute, allowed for creep to occur, were sometimes to be found.

- e. Joints were both constructed wet/tested dry and constructed dry/tested dry. It was appreciated that the former case was the most likely in practice.
- f. Slenderness was considered of greater importance than bolt diameter in its effect upon joint behaviour. (various authors, see 8). Most researchers have utilised $\frac{1}{2}$ inch or 12 mm bolts in their tests as these sizes are the most commonly used in construction.

For very large joints $\frac{3}{4}$ inch or 20 mm bolts have been used in some investigations.

The original justification for this (Trayer, 1932) has been generally confirmed by subsequent research.

- g. In reported tests, bolt hole sizes varying from 0.97 times the shank diameter to shank diameter plus 5 mm have been used for similarly sized bolts. Not, unfortunately in directly comparable circumstances. (various authors, see 9). General agreement can be found on the desirability of a bolt hole size as close as possible to bolt diameter, without the necessity of hammering the bolt through. Quite how this is to be specified is a matter for conjecture. The building codes of many countries specify maximum hole sizes of around shank diameter plus 1.5 mm and often less with the smaller bolt diameters. To what extent this close tolerance is based on practical experience or laboratory testing is not clear. Trayer, upon whose work many code provisions are based, states only that, "...The bolt holes should be of such diameter that the bolts can be driven easily. When the thickness of timbers is great this requirement may mean the boring of holes appreciably oversize. This, however, is preferable to forcible driving..." Trayer's work is clearly consulted when all other provisions fail.
- h. Friction between members was recognised as an important factor in joint strength and behaviour. (various authors, see 10).

Though a significant amount of friction between members drawn together by joint deformation was unavoidable during the later stages of test, care was taken to minimise the effects of friction up to proportional limit load. Nuts were

variously 'finger-tight', 'back half a turn', or 'slightly loose' in efforts to reduce friction. While this slight loosening of the bolts was also considered advantageous in that it simulated the possible effects of shrinkage, it was recognised that undue slackness in the joint would allow greater deformation of the joint. The variation in the possible effects of friction upon joint strength and behaviour appears to be a major reason for selection of the proportional limit load as a basis for estimation of basic design loads.

- i. Unless failure had clearly occurred beforehand, joints were generally tested to deflections of 10-12 mm and then deemed to have failed. They had exceeded their proportional limit load at this stage and further deflections would not, presumably, be contemplated by designers. Where joints were tested to greater deflections, this was done for the most part to obtain a clearer indication of the type of failure. (crushing, splitting, shear etc.). (Doyle, 1964; Larsen and Reestrup, 1969; Vermeyden, 1980).
- j. It was recognised by many researchers that factors such as seasoning, rate and type of loading, bolt hole size and slenderness were important because of their effect upon the proportional limit load and initial deflection rather than maximum joint strength, upon which their effect was considered minimal by comparison. (various authors, see 11).

The desirability of maximum joint strength as a basis for design criteria was mooted, without clear indications as to how this should be assessed. Suggestions were also made for the relation of design loads to the minimum expected levels for maximum load, or for the emphasis to be placed on strength and displacement values for specific applications rather than trying to generalise. (various authors, see 12).

Earthquake Loading

For determination of design loads under any conditions the basic data are taken from short-term loading tests such as those described in the Australian Standard used in New Zealand, AS 1649. These, modified by information from adequately replicated and properly controlled long-duration testing when this is available, together with load duration and safety factors, are deemed suitable for permanent loadings and modifi-

cation factors for varied conditions of live, short-term and impact loading applied. These data do not truly represent the results of long-term loading and the modification factors are surely educated guesses. The adoption of a more realistic method of assessing loads has been suggested. (McLain, 1975; Thurston and Flack, 1979; Wood, Cooney and Potter, 1976:)

Little information exists to provide a simple description of the motion induced by earthquake loading and different structures will probably behave differently under similar conditions. Two systems of test can be considered, taking either deflection or load as the governing criterion.

An illustration of the first test (Thurston and Flack, 1979) concerned nail-plate design, and cyclic loading tests were compared with the results obtained from monotonic loading of similar specimens. Cyclic loading tests began by pulling the connection in tension and then pushing in compression up to an applied load approximately equal to the proportional load limit obtained from earlier monotonic testing. The test was subsequently controlled by deflection with two cycles of load applied at deflections of ± 0.4 mm (deflection at proportional load limit), 0.8, 2.4, 3.2, 4.0 and 4.8 mm or until joint failure, whichever occurred earlier.

In general, stable load/deflection hysteresis loops were generated up to deflections of ± 4 mm. The authors considered this to correspond to deflections of ± 8 mm in timber/timber joints. Less than 10% of specimens tested exhibited significant reductions in peak load at these deflections with respect to those obtained during monotonic loading. Loading was carried out at the rate of 1 mm/sec during both cyclic and monotonic loading tests.

In an example of the second test system (Wood, Cooney and Potter, 1976) which included tests carried out on bolted joints, monotonic loading was again compared with cyclic loading. All loading was carried out at the rate of 0.5 kN/sec. Cyclic loading consisted of two cycles each (starting with tension) of ± 3 , 5 and 9 kN, four cycles of ± 12 kN and then cycles to failure, increasing maximum tension and compression load by 2 kN each cycle. Similar displacements were obtained at the working strength design load of 12 kN in both cyclic and monotonic testing. Insufficient testing was carried out to determine the reduction in ultimate load capacity caused by cyclic loading but indications were that this would not be significantly reduced by relatively severe cyclic

loading and that no marked degradation would occur under cycles up to half the maximum capacity.

An alternative cyclic loading sequence was recommended for future testing in which the load would be taken, in the first cycle, up to the proposed working strength design load and ten cycles carried out at that level before incrementing to the failure cycle. This has many similarities with the system used by Thurston and Flack.

Little information is available on the effects of high rates of load cycling. At low rates, as used in the above examples, the envelope of peak loads with each increment of cyclic loading appears to conform quite closely with the load/deflection curve obtained from monotonic loading of similar joints. (McLain, 1975; Thurston and Flack, 1979; Wood, Cooney and Potter, 1976). In each of these instances, both cyclic and monotonic loadings were carried out at similar rates; perhaps a similar conformity exists at other, higher loading rates.

Permissible loadings are probably more frequently set by deflection rather than strength criteria, if only to avoid subsequent damage to non-structural components and to eliminate excessive structural oscillation under ordinary conditions of live loading. In these instances there would tend to be a considerable safety factor for ultimate strength under normal design loads.

Whilst the results of tests carried out by Wood, Cooney and Potter indicate that ultimate strength may not be significantly reduced by even quite severe cyclic loading, a considerable reduction in joint stiffness also occurred. In their cyclic test regimes described previously, initial deflections of, typically, 2 mm obtained in the first loading cycles had risen close to 10 mm towards the end of the test for the same applied load of 3 kN.

If deflection had been the governing criterion these joints could well have been considered 'failures' long before ultimate joint load had been reached. Similarly, the loss of stiffness observed could mean that a joint which can perform in a satisfactory manner when subject for the first time to heavy wind or earthquake loading may subsequently not meet load/deflection criteria under normal design loads. In practice, such losses in stiffness might be overcome by grouting the joint with epoxy resin or by applying additional bracing to the structure. However, other research (Wilkinson, 1976)

indicates that joint stiffness may increase under high rates of cyclic loading, more typical of actual earthquake conditions, presumably this would be accompanied by increased stresses in the structural members themselves.

The work carried out by Wood, Cooney and Potter, was intended primarily to check the adequacy of new code requirements proposed for sub-floor bracing. Test specimens, designed to conform with sections of full-size floor structures were tested under loading conditions which duplicated the stress and strain patterns, in actual usage, of the various components. (i.e. joist, brace and bolt).

The overall capacity of the specimens, under cyclic loading, was generally found to be governed by splitting of the joist and not the ultimate load capacity of the bolted joint, despite losses in joint stiffness. Such failures may also occur in other applications but further information on the ultimate strengths of timber joints, which would assist a decision as to whether timber or joint failure would be the governing criterion for a specific structure appears to be unavailable. Under flexural loading, timber is likely to fail in a brittle manner and a timber structure therefore relies, to a large extent, upon the ductile behaviour of its metal fasteners to provide any flexibility necessary to resist such failure. This ductility may conflict with the required joint stiffness when deformation is the governing criterion in a structure.

Further information on the load/deflection characteristics of bolted joints would perhaps assist in the selection of an optimum design compromise between strength and deformation requirements, for which adequate data is at present unavailable.

CONCLUSION

This literature review confirmed the suspected lack of detailed and replicated research information on the subjects proposed for research. It also revealed that certain design criteria in current use have arbitrary origins and may therefore be suspect in practice.

FOOTNOTES

- 1 Brochard, F.X., 1961; Doyle, D.V. and Scholten, J.A., 1963; Fahlbusch, H., 1949; Johansen, K.W., 1941 and 1949; Johansen, M., Kuipers, J., and Noren, B., 1976; Kojis, D.D. and Postweiler, R.H., 1953; Kuenzi, E.W., 1953; Kuipers, J., 1963; Lantos, G., 1967; Larsen, H.J., 1975 and 1979; Larsen, H.J. and Reestrup, V., 1969; McLain, T.E., 1975; Mohler, K., 1979; Newlin, J.A., and Gahagan, J.M., 1938; Noren, B., 1951; Scholten, J.A., 1946; Smith, I., 1980; Stern, E.J., 1975; Sunley, J.G. and Brock, G.R., 1965; Thurston, S.J. and Flack, P.F., 1979; Trayer, G.W., 1928 and 1932; Vermeyden, P., 1963 and 1980; Wilkinson, T.L., 1971, 1978 and 1980; Wilkinson, T.L., and Rowlands, R.E., 1981; Wood, J.H., Cooney, R.C., and Potter, S.M., 1976.
- 2 Polish Standard BN-80/7159-04; Anderson, A. and Granum, H., 1951; Doyle, D.V., 1964; Doyle, D.V., and Scholten, J.A., 1963; Hall, A.B. and March, A.F., 1964; Johansen, K.W., 1941; Kuipers, J., 1960 and 1963; Kunesh, R.H. and Johnson, J.W., 1968; Larsen, H.J., 1975; Larsen, H.J. and Reestrup, V., 1969; Masani, N.J. and Pruthi, K.S., 1972; McLain, T.E., 1975; Newlin, J.A. and Gahagan, J.M., 1938; Noren, B., 1951; Schippers, J., 1964; Sunley, J.G. and Brock, G.R., 1965; Thurston, S.J. and Flack, P.F., 1979; Vermeyden, P., 1963 and 1980; Wilkinson, T.L., 1971 and 1978; Wood, J.H., Cooney, R.C. and Potter, S.M., 1976.
- 3 Doyle, D.V., 1964; Larsen, H.J., 1975; Larsen, H.J., and Reestrup, V., 1969; Longworth, J. and McMullin, A.E., 1963; Masani, N.J. and Pruthi, K.S., 1972; McLain, T.E., 1975; Newlin, J.A. and Gahagan, J.M., 1938; Noren, B., 1949 and 1951; Scholten, J.A., 1946; Sunley, J.G. and Brock, G.R., 1965; Wilkinson, T.L., 1976; Wood, J.H., Cooney, R.C. and Potter, S.M., 1976.
- 4 Doyle, D.V. and Scholten, J.A., 1963; Kojis, D.D. and Postweiler, R.H., 1953; Kunesh, R.H. and Johnson, J.W., 1968; Mack, J.J., 1981; Noren, B., 1949; Vermeyden, P., 1980; Wilkinson, T.L., 1976.
- 5 Hellawell, C.R., 1965; Kuipers, J. and Vermeyden, P., 1965; Mack, J.J., 1981; Newlin, J.A. and Gahagan, J.M., 1938; Sunley, J.G. and Brock, G.R., 1965; Trayer, G.W., 1928 and 1932; Vermeyden, P., 1980; Wilkinson, T.L., 1971 and 1978.
- 6 Larsen, H.J. and Reestrup, V., 1969; Newlin, J.A. and Gahagan, J.M., 1938; Noren, B., 1951; Trayer, G.W., 1928 and 1932; Vermeyden, P., 1980; Wilkinson, T.L., 1971.
- 7 AS 1949; BN-80/7159-04; Andersen, A. and Granum H., 1951; Doyle, D.V., 1964; Doyle, D.V., and Scholten, J.A., 1963; Hall, A.B. and March, A.F., 1964; Johansen, K.W., 1941; Kuipers, J., 1960 and 1963; Kunesh, R.H. and Johnson, J.W., 1968; Larsen, H.J. and Reestrup, V., 1969; Masani, N.J. and Pruthi, K.S., 1972; McLain, T.E., 1975; Newlin, J.A. and Gahagan, J.M., 1938; Noren, B., 1951; Schippers, J., 1964; Sunley, J.G. and Brock, G.R., 1965; Thurston, S.J. and Flack, P.F., 1979; Trayer, G.W., 1928 and 1932; Vermeyden, P., 1963 and 1980; Wilkinson, T.L., 1971 and 1978; Wood, J.H., Cooney, R.C. and Potter, S.M., 1976.

- 8 Brochard, F.X., 1961; Johansen, K.W., 1949; Johansen, M., Kuipers, J. and Noren, B., 1976; Kojis, D.D. and Postweiler, R.H., 1953; Kuenzi, E.W., 1953; Kuipers, J., 1960 and 1963; Kuipers, J. and Vermeyden, P., 1965; Kunesh, R.H. and Johnson, J.W., 1968; Larsen, H.J., 1975; Larsen, H.J. and Reestrup V., 1969; Mack, J.J., 1981; Masani, N.J. and Pruthi, K.S., 1972; McLain, T.E., 1975; Newlin, J.A. and Gahagan, J.M., 1938; Noren, B., 1951; Schippers, J., 1964; Scholten, J.A., 1946; Smith, I., 1980; Trayer, G.W., 1928 and 1932; Vermeyden, P., 1963 and 1980; Wilkinson, T.L., 1976 and 1978.
- 9 BN-80/7159-04; Andersen, A. and Granum, H., 1951; Doyle, D.V., 1964; Doyle, D.V. and Scholten, J.A., 1963; Hall, A.B. and March, A.F., 1964; Johansen, K.W., 1941; Kuipers, J., 1960 and 1963; Kunesh, R.H. and Johnson, J.W., 1968; Larsen, H.J., 1975; Larsen, H.J. and Reestrup, V., 1969; Masani, N.J. and Pruthi, K.S., 1972; McLain, T.E., 1975; Newlin, J.A. and Gahagan, J.M., 1938; Noren, B., 1951; Schippers, J., 1964; Scholten, J.A., 1946; Sunley, J.G. and Brock, G.R., 1965; Thurston, S.J. and Flack, P.F., 1979; Vermeyden, P., 1963 and 1980; Wilkinson, T.L., 1971, 1976 and 1978; Wood, J.H., Cooney, R.C. and Potter S.M., 1976.
- 10 Brochard, F.X., 1961; Doyle, D.V. and Scholten, J.A., 1963; Fahlbusch, H., 1949; Johansen, K.W., 1941 and 1949; Johansen, M., Kuipers, J. and Noren, B., 1976; Kojis, D.D. and Postweiler, R.H., 1953; Kuenzi, E.W., 1953; Kuipers, J., 1963; Kuipers, J. and Vermeyden P., 1965; Lantos, G., 1967; Larsen, H.J., 1975 and 1979; Larsen, H.J. and Reestrup, V., 1969; McLain, T.E., 1975; Mohler, K., 1979; Newlin, J.A. and Gahagan, J.M., 1938; Noren, B., 1951; Schippers, J., 1964; Scholten, J.A., 1946; Smith, I., 1980; Stern, E.J., 1975; Sunley, J.G. and Brock, G.R., 1965; Thurston, S.J. and Flack, P.F., 1979; Trayer, G.W., 1928 and 1932; Vermeyden, P., 1963 and 1980; Wilkinson, T.L., 1971, 1976 and 1978; Wilkinson, T.L. and Rowlands, R.E., 1981; Wood, J.H., Cooney, R.C. and Potter, S.M., 1976.
- 11 Brochard, F.X., 1961; Hellawell, C.R., 1965; Johansen, K.W., 1949; Johansen, M., Kuipers, J. and Noren, B., 1976; Kojis, D.D. and Postweiler, R.H., 1953; Kuenzi, E.W., 1953; Kuipers, J. and Vermeyden, P., 1965; Kunesh, R.H. and Johnson, J.W., 1968; Larsen, H.J., 1975; Larsen, H.J. and Reestrup, V., 1969; Mack, J.J., 1981; Masani, N.J. and Pruthi, K.S., 1972; McLain, T.E., 1975; Newlin, J.A. and Gahagan, J.M., 1938; Noren, B., 1951; Scholten, J.A., 1946; Smith, I., 1980; Sunley, J.G. and Brock, G.R., 1965; Trayer, G.W., 1928 and 1932; Vermeyden, P., 1980; Wilkinson, T.L. 1978.
- 12 Hellawell, C.R., 1965; Kuipers, J. and Vermeyden, P., 1965; Larsen, H.J., 1979; Noren, B., 1951; Sunley, J.G. and Brock, G.R., 1965; Thurston, S.J. and Flack, P.F., 1979; Wood, J.H., Cooney, R.C. and Potter, S.M., 1976.

REFERENCES

Standards and Codes

Australian Standard AS 1949-1974; Determination of Basic Working Loads for Metal Fasteners for Timber: Standards Association of Australia.

Australian Standard AS 1720-1975; Standards Association of Australia Timber Engineering Code: Standards Association of Australia.

British Standard Code of Practice CP 112 : Part 2 : 1971. The Structural Use of Timber : British Standards Institution.

Canadian Wood Construction WJ4 1977; Connectors and Supports : Canadian Wood Council.

National Design Specification for Stress-Grade Lumber and its Fastenings 1977 : National Forest Products Association, Washington, D.C.

New Zealand Standard. NZS 3603 : 1981, Code of Practice for Timber Design: Standards Association of New Zealand.

Polish Standard BN-80/7159-04 : Parts 00-05: Structures from Wood and Wood-based Materials. Methods of Test and Strength Criteria for Joints with Mechanical Fasteners. C.I.B. Report No. W18, 13-7-1, Otaniemi, Finland, June 1980.

General

Andersen, A. and Granum, H., 1951, Forsøk med Tømmerforbinderne, Alligator, Bulldog, Rox og Stjerne: Norges Teknisk, Vitenskapelige, Forskningsrad: Report No. 2, Oslo.

Booth, L.G. and Reece, P.O., 1967, The Structural Use of Timber, London.

Brochard, F.X., 1961, A Study of Frameworks with Nailed and Bolted Joints: Proceedings of the First International Conference on Timber Engineering, Southampton.

Doyle, D.V., 1964, Performance of Joints with 8 Bolts in Laminated Douglas Fir: U.S Forest Products Laboratory, Research Paper FPL 10.

Doyle, D.V. and Scholten, J.A., 1963, Performance of Bolted Joints in Douglas Fir : U.S. Forest Products Laboratory, Research Paper FPL 2.

Fahlbusch, H., 1949, Ein Beitrag zur Frage der Tragfähigkeit von Bolzen in Holz bei Statisher Belastung: Disertation, Technische Hochschule, Braunschweig.

Hall, A.B. and March, A.F., 1964, An Investigation into the Variation of Behaviour of a Two-member, Single-nailed Tension Joint when Subjected to Varying Strain Rates; Timber Research and Development Association Research Report E/RR/20.

Hellawell, C.R., 1965, Mechanical Fasteners and Timber Jointing in New Zealand, from a Laboratory Viewpoint, C.I.B. Report No. 8, Modern Timber Joints.

Johansen, K.W., 1949, Theory of Timber Connections : International Association for Bridge and Structural Engineering, Vol 9, pp 249-269.

Johansen, K.W., 1941, Forsøg med Traeforbindelser I; Meddelelse No. 10, Laboratorium for Bygningstatik, Danmarks Tekniske Højskole, København.

Johansen, M., Kuipers, J., and Noren, B., 1976, Rules for Evaluation of Values of Strength and Deformation from Test Results - Mechanical Timber Joints. C.I.B. Report No. W18, 6-7-3, Aalborg.

Kojis, D.D and Postweiler, R.H., 1953, Allowable Loads for Common Bolts at Various Angles to the Grain for Southern Yellow Pine; Journal of the Forest Products Research Society 3(3) : 21-26.

Kuenzi, E.W., 1953, Theoretical Design of a Nailed or Bolted Joint under Lateral Load; United States Department of Agriculture, Forest Service Report D 1951.

Kuipers, J., 1963, De Veiligheid van Constructies, Onderworpen aan Combinaties van Verschillende Belastingen : Heron II (1963) No 2/3.

Kuipers, J., 1960, Onderzoek van Ringdeuvelverbindingen de Scheve, Verbindingen: Stevin Laboratorium Report No. 4, 60.1, HV, 18.

- Kuipers, J. and Vermeyden, P., 1965, Research on Timber Joints in the Netherlands: C.I.B. Report No 8, Modern Timber Joints.
- Kunesh, R.H. and Johnson, J.W., 1968, Strength of Multiple-Bolt Joints: Influence of Spacing and Other Variables: United States Forest Research Laboratory Report T-24.
- Lantos, G., 1967, Load Distribution in Multiple Mechanical Fasteners in Joints Subjected to Direct Load: Timber Research and Development Association, Research Report E/RR/8.
- Larsen, H.J., 1975, Determination of Load-Slip Curves for Bolts and Nails: Paper prepared for the International Union of Forestry Research Organisations - Division V, Delft.
- Larsen, H.J., 1979, Design of Bolted Joints: C.I.B Report No W 18, 12-7-2, Bordeaux.
- Larsen, H.J. and Reestrup, V., 1969, Tests of Screws in Wood: Bygningsstatistiske Meddelelse Vol 40. No. 1.
- Longworth, J. and McMullin, A.E., 1963, Effect of Moisture Content on Strength of Bolted Timber Connections. Forest Products Journal, Vol. 13(3): 104-107.
- Mack, J.J., 1981, The Strength of Bolted Joints in Australian Timbers : Division of Building Research, Technical Paper (Second Series) No. 45: Commonwealth Scientific and Industrial Research Organization, Australia.
- Masani, N.J., and Pruthi, K.S., 1972, Bolted Joints for Prefabricated Timber Structures, Part II: Indian Forest Leaflet No. 192 : Indian Forest Research Institute.
- McLain, T.E., 1975, Curvilinear Load-Slip Relations in Laterally-Loaded Nailed Joints. Ph. D. Dissertation, Colorado State University.
- Mohler, K., 1979, Stresses Perpendicular to Grain: C.I.B. Report No W18, 11-6-2, Vienna.
- Newlin, J.A. and Gahagan, J.M., 1938, Lag-Screw Joints: Their Behaviour and Design: United States Department of Agriculture, Tech. Bull No 597.

Noren, B., 1949, Traforbund med Bultar och Mellanlagg: Byggmasteren No 19.

Noren, B., 1948, Bultforbund i Tra : Teknisk Tidskrift, 28 Aug. P 535-538.

Noren, B., 1951, Strength of Bolted Wood Joints. Especially the Influence of Washer Size on Strength and Stiffness in Single Shear: Commonwealth Scientific and Industrial Research Organization, Australia, Translation No. 9737. (Translated from Svenska Traforskningsinstitutet, Tratekniska Avdelningen, Meddelande 22 B).

Noren, B., 1948, Slutredogorelse for Forskningsuppgift. F. 85 : Statens Kommitte for Byggnadsforskning. Stockholm, (Kth and Cth Library).

Schippers, J., 1964, Proeven op Rechte on Scheve I - Assige Verbindingen met TECO Ringdeuvels. Dia. 112 mm en Dia. 73 mm. Stevin Laboratorium Report No 4,63,3,R,4.

Scholten, J.A., 1946, Strength of Bolted Timber Joints: United States Department of Agriculture, Forest Products Laboratory, Research Paper No. 1202.

Smith, I., 1980, A review of Analytical and Empirical Models used to Predict the Strength and Stiffness Characteristics of Timber Joints with Dowel Type Connectors: Timber Research and Development Association Research Report 1/80.

Stern, E.J., 1975, Mechanical Fasteners and Fastening in Timber Structures: C.I.B. Report No. W18, 4-7-1, Paris.

Sunley, J.G. and Brock, G.R., 1965, Methods of Test and the Determination of Working Loads: C.I.B. Report No. 8, Modern Timber Joints.

Thurston, S.J. and Flack, P.F., 1979, Monotonic and Cyclic Testing of Timber Connections using Nailed Steel Side Plates: Ministry of Works Department, Report No 5-79/4, Structures Laboratory, Central Laboratories, Lower Hutt.

Trayer, G.W., 1928, Bearing Strength of Wood Under Steel Aircraft Bolts and Washers and Other Factors Influencing Fitting Design: National Advisory Committee, Aeronautics Technology Notes 296.

Trayer, G.W., 1932, The Bearing Strength of Wood Under Bolts: United States Department of Agriculture, Technical Bulletin No. 332.

Vermeyden, P., 1963, Proeven op Kramplaatverbindingen: Stevin Laboratorium Report No 4, 63, 13, K, 3.

Vermeyden, P, 1980, Tests on Bolted Joints: C.I.B. Report No. W 18, 13-7-7, Otaniemi.

Wilkinson, T.L., 1980, Assessment of Modification Factors for a Row of Bolts on Timber Connectors: United States Department of Agriculture, Forest Service Research Paper FPL 376.

Wilkinson, T.L., 1971, Bearing Strength of Wood under Embedment Loading of Fasteners: United States Department of Agriculture, Forest Service Research Paper FPL 163.

Wilkinson, T.L. 1976 : Vibrational Loading of Mechanically Fastened Wood Joints : United States Department of Agriculture, Forest Service Research Paper FPL 650.

Wilkinson, T.L., 1978, Strength of Bolted Wood Joints with Various Ratios of Member Thickness: United States Department of Agriculture, Forest Service Research Paper FPL 314.

Wilkinson, T.L., and Rowlands, R.E., 1981, Analysis of Mechanical Joints in Wood: Experimental Mechanics, Vol. 21, Nov. No 11, pp 408-414.

Wood, J.H., Cooney, R.C., and Potter, S.M., 1976, Cyclic Testing of Connections for Light Timber Construction: Ministry of Works Department, Report No 5-76/12, Structures Laboratory, Central Laboratories, Lower Hutt.

BIBLIOGRAPHY

Standard and Codes

Australian Standard 1949-1974; Determination of Basic Working Loads for Metal Fasteners for Timber: Standards Association of Australia.

Australian Standard 1720-1975; Standards Association of Australia Timber Engineering Code: Standards Association of Australia.

British Standard Code of Practice CP 112 : Part 2 : 1971. The Structural Use of Timber : British Standards Institution.

Canadian Wood Construction WJ4 1977; Connectors and Supports : Canadian Wood Council.

National Design Specification for Stress-Grade Lumber and its Fastenings 1977 : National Forest Products Association, Washington, D.C.

New Zealand Standard. NZS 3603 : 1981, Code of Practice for Timber Design: Standards Association of New Zealand.

New Zealand Standard. NZS 4203 : 1976, Code of Practice for General Structural Design and Loading of Buildings: Standards Association of New Zealand.

Polish Standard BN-80/7159-04 : Parts 00-05: Structures from Wood and Wood-based Materials. Methods of Test and Strength Criteria for Joints with Mechanical Fasteners. C.I.B. Report No. W18, 13-7-1, Otaniemi, Finland, June 1980.

Wood Handbook: United States Department of Agriculture, Handbook No. 72, 1955.

General

Andersen, A. and Granum, H., 1951, Forsøk med Tømmerforbinderne, Alligator, Bulldog, Rox og Stjerne: Norges Teknisk, Vitenskapelige, Forskningsrad: Report No. 2, Oslo.

Booth, L.G. and Reece, P.O., 1967, The Structural Use of Timber, London.

Brochard, F.X., 1961, A Study of Frameworks with Nailed and Bolted Joints: Proceedings of the First International Conference on Timber Engineering, Southampton.

Doyle, D.V., 1964, Performance of Joints with 8 Bolts in Laminated Douglas Fir: U.S Forest Products Laboratory, Research Paper FPL 10.

Doyle, D.V. and Scholten, J.A., 1963, Performance of Bolted Joints in Douglas Fir : U.S. Forest Products Laboratory, Research Paper FPL 2.

Fahlbusch, H., 1949, Ein Beitrag zur Frage der Tragfähigkeit von Bolzen in Holz bei Statisher Belastung: Disertation, T.H. Braunschweig.

Feldborg, T. and Johansen, M., 1981, Wood Trussed Rafter Design. C.I.B. Report No. W18, 14-14-1. Warsaw.

Hall, A.B. and March, A.F., 1964, An Investigation into the Variation of Behaviour of a Two-member, Single-nailed Tension Joint when Subjected to Varying Strain Rates; T.R.A.D.A. Research Report E/RR/20.

Hellawell, C.R., 1965, Mechanical Fasteners and Timber Jointing in New Zealand, from a Laboratory Viewpoint, C.I.B. Report No. 8, Modern Timber Joints.

Johansen, K.W., 1949, Theory of Timber Connections : International Assn. for Bridge and Structural Eng., Vol 9, pp 249-269.

Johansen, K.W., 1941, Forsøg med Træforbindelser I; Meddelelse No. 10, Lab. for Bygningstatik, Danmarks Tekniske Højskole, København.

Johansen, M., Kuipers, J., and Noren, B., 1976, Rules for Evaluation of Values of Strength and Deformation from Test Results - Mechanical Timber Joints. C.I.B. Report No. W18, 6-7-3, Aalborg.

Kojis, D.D and Postweiler, R.H., 1953, Allowable Loads for Common Bolts at Various Angles to the Grain for Southern Yellow Pine; J. For. Prod. Res. Society 3(3) : 21-26.

Kuenzi, E.W., 1953, Theoretical Design of a Nailed or Bolted Joint under Lateral Load; U.S. Dept. of Agri., For. Service Report D 1951.

Kuipers, J., 1963, De Veiligheid van Constructies, Onderworpen aan Combinaties van Verschillende Belastingen : Heron II (1963) No 2/3.

Kuipers, J., 1960, Onderzoek van Ringdeuvelverbindingen de Scheve, Verbindingen: Stevin Laboratorium Report No. 4, 60.1, HV, 18.

Kuipers, J. and Vermeyden, P., 1965, Research on Timber Joints in the Netherlands: C.I.B. Report No 8, Modern Timber Joints.

Kunesh, R.H. and Johnson, J.W., 1968, Strength of Multiple-Bolt Joints: Influence of Spacing and Other Variables: U.S. Forest Research Laboratory Report T-24.

Lantos, G., 1967, Load Distribution in Multiple Mechanical Fasteners in Joints Subjected to Direct Load: T.R.A.D.A. Research Report E/RR/8.

Larsen, H.J., 1975, Determination of Load-Slip Curves for Bolts and Nails: Paper prepared for the International Union of Forestry Research Organisations - Division V, Delft, April.

Larsen, H.J., 1979, Design of Bolted Joints: C.I.B Report No W 18, 12-7-2, Bordeaux.

Larsen, H.J. and Reestrup, V., 1969, Tests of Screws in Wood: Bygningsstatistiske Meddelelse Vol 40. No. 1.

Longworth, J. and McMullin, A.E., 1963, Effect of Moisture Content on Strength of Bolted Timber Connections. For. Prod. J. 13(3): 104-107.

Mack, J.J., 1981, The Strength of Bolted Joints in Australian Timbers : Div. of Building Res. Tech. Paper (Second Series) No. 45: C.S.I.R.O.

Masani, N.J., and Pruthi, K.S., 1972, Bolted Joints for Prefabricated Timber Structures, Part II: Indian Forest Leaflet No. 192 : Indian Forest Research Institute.

McLain, T.E., 1975, Curvilinear Load-Slip Relations in Laterally-Loaded Nailed Joints. Ph. D. Dissertation, Colorado State University.

Mohler, K., Stresses Perpendicular to Grain: C.I.B. Report No W18, 11-6-2, Vienna.

Newlin, J.A. and Gahagan, J.M., 1938, Lag-Screw Joints: Their Behaviour and Design:

U.S. Dept. of Agriculture, Tech. Bull No 597.

Noren, B., 1959, Traforbund med Bultar och Mellanlagg: Byggmasteren No 19.

Noren, B., 1948, Bultforbund i Tra : Teknisk Tidskrift, 28 Aug. P 535-538.

Noren, B., 1951, Strength of Bolted Wood Joints. Especially the Influence of Washer Size on Strength and Stiffness in Single Shear: C.S.I.R.O. Translation No 9737. (Translated from Svenska Traforskningsinstitutet, Tratekniska Avdelningen, Meddelande 22 B.

Noren, B., 1948, Slutredogorelse for Forskningsuppgift. F. 85 : Statens Kommitte for Byggnadsforskning. Stockholm (Kth and Cth Library).

Pearson, R.G., Kloot, N.H. and Boyd, J.D., 1974, Timber Engineering Design Handbook: C.S.I.R.O. Division of Forest Products in assoc. with Jacaranda Press.

Schippers, J., 1964, Proeven op Rechte on Scheve I - Assige Verbindingen met TECO Ringdeuvels. Dia. 112 mm en Dia. 73 mm. Stevin Laboratorium Report No 4,63,3,R,4.

Scholten, J.A., 1946, Strength of Bolted Timber Joints: U.S.D.A. F.P.L. Research Paper No. 1202.

Smith, I., 1980, A review of Analytical and Empirical Models used to Predict the Strength and Stiffness Characteristics of Timber Joints with Dowel Type Connectors: T.R.A.D.A. Research Report 1/80.

Spodgrass, H.D. and Gleaves, W.W., 1960, Effect of End Distance on Strength of Single Bolt Joints: F.R.L. Oregon State University (unpublished). (Not seen, referred to in 24.).

Stern, E.J., 1975, Mechanical Fasteners and Fastening in Timber Structures: C.I.B. Report No. W18, 4-7-1, Paris.

Sunley, J.G. and Brock, G.R., 1965, Methods of Test and the Determination of Working Loads: C.I.B. Report No. 8, Modern Timber Joints, 1965.

Thurston, S.J. and Flack, P.F. 1979: Monotonic and Cyclic Testing of Timber Connections using Nailed Steel Side Plates. M.W.D. Cent. Labs. Report No 5-79/4.

Trayer, G.W., 1928, Bearing Strength of Wood Under Steel Aircraft Bolts and Washers and Other Factors Influencing Fitting Design: National Advisory Committee, Aeronautics Tech. Notes 296.

Trayer, G.W., 1932, The Bearing Strength of Wood Under Bolts: U.S.D.A. Tech. Bull. No. 332.

Vermeyden, P., 1963, Proeven op Kramplaatverbindingen: Stevin Laboratorium Report No 4, 63, 13, K, 3.

Vermeyden, P., 1980, Tests on Bolted Joints: C.I.B. Report No. W 18, 13-7-7, Otaniemi.

Walford, G.B., 1977, Tests on Bolted Joints Reinforced with "Gang-Nails": New Zealand Forest Service, Forest Research Institute, Forest Products Laboratory Report No. FP/TE77 (unpublished).

Walford, G.B., 1980, Derivation of Design Loads for Timber Fasteners: New Zealand Forest Service, Forest Research Institute, Forest Products Division Report No FP/TE 36 (unpublished).

Wilkinson, T.L., 1980, Assessment of Modification Factors for a Row of Bolts on Timber Connectors: U.S.D.A. Forest Service Research Paper FPL 376.

Wilkinson, T.L., 1971, Bearing Strength of Wood under Embedment Loading of Fasteners: U.S.D.A. Forest Service Research Paper FPL 163.

Wilkinson, T.L., 1976, Vibrational Loading of Mechanically Fastened Wood Joints : United States Department of Agriculture, Forest Service Research Paper FPL650.

Wilkinson, T.L., 1978, Strength of Bolted Wood Joints with Various Ratios of Member Thickness: U.S.D.A. Forest Service Research Paper FPL 314.

Wilkinson, T.L., and Rowlands, R.E., 1981, Analysis of Mechanical Joints in Wood: Experimental Mechanics, Vol. 21, Nov. No 11, pp 408-414.

Wood, J.H., Cooney, R.C., and Potter, S.M., 1976, Cyclic Testing of Connections for Light Timber Construction: M.W.D. Report No 5-76/12, Structures Laboratory, Central Laboratories, Lower Hutt.

INTERNATIONAL COUNCIL FOR BUILDING RESEARCH STUDIES AND DOCUMENTATION
WORKING COMMISSION W18 - TIMBER STRUCTURES

BOLTED TIMBER JOINTS
PRACTICAL ASPECTS OF CONSTRUCTION AND DESIGN
A SURVEY

by

N Harding

Building Research Association of New Zealand
New Zealand

LILLEHAMMER

NORWAY

MAY/JUNE 1983

INTERNATIONAL COUNCIL FOR BUILDING RESEARCH STUDIES AND DOCUMENTATION
WORKING COMMISSION W18 - TIMBER STRUCTURES

BOLTED TIMBER JOINTS
PRACTICAL ASPECTS OF CONSTRUCTION AND DESIGN
A SURVEY

by

N Harding

Building Research Association of New Zealand
New Zealand

LILLEHAMMER

NORWAY

MAY/JUNE 1983

INTERNATIONAL COUNCIL FOR BUILDING RESEARCH STUDIES AND DOCUMENTATION

WORKING COMMISSION W18 - TIMBER STRUCTURES

BOLTED TIMBER JOINTS
PRACTICAL ASPECTS OF CONSTRUCTION AND DESIGN
A SURVEY

by

N Harding

Building Research Association of New Zealand
New Zealand

LILLEHAMMER

NORWAY

MAY/JUNE 1983

UNPUBLISHED
REPORT

UP 185

JAN 1983

BOLTED TIMBER JOINTS
PRACTICAL ASPECTS OF CONSTRUCTION AND DESIGN

A SURVEY

N. HARDING

This confidential report has been issued to for his/her personnel use. It may not be referred to in any publication, nor may its contents be divulged.

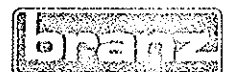

CONTENTS

PAGE

1.	Introduction	1
2.	The Use and Availability of Components	3
2.1	General	3
2.2	Bolts	3
2.3	Coach Screws	4
2.4	Washers	4
2.5	Timbers	5
3.	The Placing of Bolts	6
3.1	General	6
3.2	Edge Distance	6
3.3	End Distance	6
4.	Ultimate Strength Design - Load/Deflection Relationship	7
5.	Discussion	8
6.	Conclusions	10
7.	Comment	10
8.	References	12

BOLTED TIMBER JOINTS:

PRACTICAL ASPECTS OF CONSTRUCTION AND DESIGN:

A SURVEY

INTRODUCTION

A research project is to be carried out by BRANZ to prepare design information on bolted timber connections, loaded in shear, in areas which are not at present adequately covered by available codes of practice and timber design handbooks. These areas are:

- a) Connections which have bolt edge and end distances less than the minima currently specified in NZS 3603:1981, the Code of Practice for Timber Design.
- b) Connections which have smaller washers than those currently specified in NZS 3603.
- c) Ultimate strength design values of bolted joints.
- d) Load/deflection relationships of connections, with reference to rate and type of loading.

A survey of literature relevant to the proposed research was carried out prior to formulation of a definitive experimental design. The results of that survey, together with further background information on the inception of this research programme are discussed in an earlier report (Harding, 1983). In general the literature survey emphasized the lack of detailed and replicated research data available in the proposed areas of investigation. Rather more surprising were the tenuous and sometimes arbitrary origins of certain design criteria revealed by the survey.

A further survey has been carried out to examine the practical aspects of typical joints and bolt sizes currently employed in combination with different forms of construction in current use. The availability and demand for various components (i.e. bolts by diameter, length, coating and head type; washers by thickness, size and coating) were also considered.

The survey was intended to assist in the design of the subsequent experimental programme and was thus somewhat limited with this objective in mind. This report on the results of the survey represents a subjective interpretation, by the author, of information and opinions provided by builders, designers, engineers and suppliers of components from diverse areas throughout New Zealand and cannot be proved to any significant degree, rather it adds to the general knowledge of the situation from which the programme was originally conceived.

The report is intended to provide a basis for discussion and suggestions as to the subsequent emphasis of the research. The main conclusion is that the building code provisions, with regard to bolted timber joints, are commonly violated and seldom enforced.

THE USE AND AVAILABILITY OF COMPONENTS

General

The use of bolted timber joints was confined almost entirely to foundation bracing and pole-frame structures. For other applications, nailing or stapling offered more convenient methods of fixing and bolted joints were used by builders only where obliged by the provisions of a New Zealand Standard relevant to a particular structure, or to meet a specific design requirement.

In most districts, especially those close to the main centres of population, components suitable for bolted joints as specified in NZS 3603 were readily available - although not necessarily utilized. Of interest were the definite local "preferences" for particular types and sizes of components revealed by the survey. These are discussed in further detail under their specific headings, but it is noteworthy that other types and sizes of component were not generally available in these districts, having "minimal demand", according to the suppliers, or being "difficult to obtain", in the experience of the builders. Coach screws were not generally available in quantity nor were bolts of sizes greater than 12 x 150 mm.

Bolts

The largest numbers of bolts held in stock and used by the industry were 150 mm in length, 100 mm bolts were the smallest in common usage. Depending upon local preference the bolts were of either 10 or 12 mm diameter and either hexagon-headed or coach-bolts. Most of the bolts were zinc-coated although the use of black bolts or plain mild-steel bolts was common in some areas.

N.B. In this report the term "zinc-coated" refers for the most part to hot-dip galvanized components. A considerable number of zinc-plated components were observed in use and these are also included in the term. With regard to bolts these occurred largely in 10 mm diameter.

The particular bolt type most commonly found was the 12 x 150 mm, zinc-coated coach-bolt. These probably account for well over half of all bolts used by the industry.

Coach-bolts of 10 and 12 mm nominal diameters are also available in a reduced-shank version, some 1.5 - 2 mm less in diameter than the nominal-sized bolts. A clear

distinction between the two types was not always made in practice, either by users or suppliers.

In general, where longer bolts were required 12 mm nominal diameter threaded rods were used, most commonly in lengths of either 200 or 300 mm. These were the only sizes found in significant quantities. Only a very few 20 mm diameter rods were noted and apparently, these are seldom used, multiple 12 mm bolted joints being preferred. Most of the threaded rods were galvanised but, in some districts, black bolts or uncoated mild steel bolts were the preferred type.

Coach Screws

The use of coach-screws was avoided by all builders, long threaded rods or transverse nail plates being used in their place wherever possible. Their unpopularity was due to the tedious nature of the fixing method and also because of subsequent difficulties in assessing the hole size and the method of "driving". Problems of splitting and drying/shrinkage cracking associated with the close tolerances required by the code were also mentioned.

Although no coach-screwed joints were encountered during the survey, descriptions of fitting methods used in the past were common. Typically, these involved screws hammered into holes of shank diameter to depths well below that required by NZS 3603 for correctly fitted coach-screws. Given the somewhat fiddlesome nature of coach-screwed joints constructed in accordance with the code, the occurrence of such "modifications" is not altogether to be unexpected and appeared to be regarded as unavoidable by both builders and designers. Except in "one-off" applications, for which adequate supervision would be feasible, coach-screws were not considered by either to be appropriate for structural purposes.

Washers

For bolts up to 150 mm in length, round washers of 28 - 38 mm external and 14 - 17 mm internal diameters were commonly used. These washers were of two distinct types: 1.5 mm zinc-plated (engineering washers) and 3 mm thick, either galvanised or uncoated, mild steel. Most common were engineering washers of 28 or 35 mm external diameter (c.f. a head diameter of 27 mm for 12 mm diameter coach-bolts). The 38 mm engineering washers sometimes found had a large internal diameter of 20 mm and required the use of a second, smaller washer - not always provided - to supply a supposedly adequate bearing for the bolt heads.

Washers as specified in NZS 3603 for use with 10 and 12 mm diameter bolts (i.e. not less than 50 x 50 mm square x 3 mm thick, or round and of equivalent thickness and bearing area) were seldom found with these bolts. Their use was considered to be superfluous under the nuts of coach bolts, but they were no more commonly found in combination with hexagon-headed bolts. These large washers, in galvanised or uncoated mild steel, achieved wider usage with the longer bolts in pole-frame structures. Similar 50 x 50 x 3 mm washers, - with suitably larger holes, - were also used with 20 mm diameter bolts instead of the 65 x 65 x 5 mm washers required by NZS 3603.

Occasional bolted joints without washers were noted in many structures, but these formed a small proportion of the total.

Apparently washers are normally provided along with the bolts by the supplier - the builder merely ordering "3603 bolts and washers". The size of the washers is therefore liable to vary, depending on which supplier is patronised. This was given as an excuse for non-compliance by one or two builders, but builders generally considered washer sizes, as specified in the code, to be excessive and did not see any need to justify their use of the smaller sizes.

Whilst little concern was expressed by designers regarding the reduced sizes (c.f. NZS 3603) of washers commonly used in bolted joints, some trepidation was felt over the widespread use of the 1.5 mm thick engineering washers. These were thought to provide inadequate support for the bolt-head, being more liable to deform under load than similar 3 mm washers. This objection has a greater relevance to anchor fixings than to joints loaded in lateral shear and seems something of a nicety while reductions of up to 80% in the code required washer bearing area are at the same time considered of minor import. The behaviour of anchor fixings is not within the scope of this research programme, nevertheless observations during the survey indicated that washers as specified in NZS 3603 are no more commonly used in these fixings than in other joint types.

Timbers

The only timbers noted during the survey were Radiata Pine and Douglas Fir. These were almost invariably of either 50 or 75 mm thicknesses except in the larger pole-frame structures where 100, 150 and 200 mm timbers were also encountered.

THE PLACING OF BOLTS

General

In most situations no real problems existed to prevent compliance with the strictures of NZS 3603 regarding the placing of bolts, with the possible exception of bolt hole size. Bolt holes were always drilled 2-3 mm greater than bolt diameter (c.f. NZS 3603 specified maximum: bolt diameter + 1.5 mm). Problems of splitting, drying/shrinkage cracking and with passing bolts through multiple-member joints were given as reasons for non-compliance. Bolt shank diameters were considered by many users often to be in excess of nominal sizes thereby making the close tolerances required by the building code to be impracticable.

Most builders appeared quite conversant with code provisions concerning end and edge spacings of bolted timber joints but were unconvinced of their validity. No problems or failures had yet been experienced using components or spacings of reduced dimensions and their joints were "never questioned" by building inspectors. Many builders were clearly of the opinion that "scientists" had prepared the building codes, basing them on a mass of laboratory testing with little regard to any practical considerations and having limited relevance to actual structures. This was a view shared by many designers. Little scientific justification for the relevant code provisions was revealed by our literature search.

Edge Distance

For joints loaded parallel to the grain the edge distance of two bolt diameters specified in NZS 3603, which for the commonly used 10 and 12 mm diameter bolts approximates the old familiar inch, is a distance easily judged, it "looks right" and there was little evidence of it being greatly undercut. Unfortunately, similar reasoning must occur when the joints are loaded perpendicular to the grain, for the minimum distance to the loaded edge of four diameters allowed by NZS 3603 also showed a tendency in practice towards two diameters. Edge distances of 2.5-3 diameters were quite common in such joints.

End Distance

The minimum distance of eight bolt diameters to the loaded end of joints loaded parallel to the grain was thought excessive by most builders and frequently disregarded. End distances as low as four diameters were not uncommon.

No minimum end distances are specified in NZS 3603 for loadings perpendicular to the grain. In applications where some such criterion would be necessary a practical minimum is constrained by the splitting characteristics of the timber, but some tensile force is also likely to exist. However, no such applications were noted during the survey. It is of interest to note that the corresponding codes of Canada (Canadian Wood Construction WJ4, 1977: Connectors and Supports); Great Britain (British Standard Code of Practice CP 112: Part 2:1971. The Structural Use of Timber) and the U.S.A. (National Design Specification for Stress-Grade Lumber and its Fastenings, 1977), specify a minimum end distance of four diameters for bolted timber joints loaded perpendicular to the grain. An experimental bases for this distance, which corresponds with the minimum unloaded end distance for bolted joints acting parallel to the grain specified by these codes, did not emerge during the earlier literature survey.

ULTIMATE STRENGTH DESIGN - LOAD/DEFLECTION RELATIONSHIPS

The ultimate resistance of a structure against collapse depends upon either ultimate joint strength or the strength of the structural members themselves. Timber is not a ductile material and, when subject to large deformations such as those resultant from earthquake or high wind loading conditions, depends upon the ductility provided by its metal fastenings (i.e. their deformation) to avoid collapse. With deformation more often the criterion governing joint design, most joints are designed to incorporate a considerable degree of stiffness under normal working loads. In the view of many designers, this joint stiffness ensures that failure of the timber members is almost always the governing criterion of structural failure and present code requirements oblige the use of needlessly strong joints, - "putting 20 kN joints in 10 kN structures", as one described it. This view is to some extent supported by the results of past research work (Wood, Cooney and Potter, 1976). A common sentiment appeared to be that current design requirements were based upon tests carried out on components and, as such, had limited relevance to the behaviour of the structure as a whole. This is an interesting parallel with the views expressed by many builders and may explain the general lack of concern expressed by designers with regard to violations of code provisions for joint design.

The acquisition of adequate load/deflection data, particularly in relation to cyclic (i.e. simulated earthquake) loading, was considered highly desirable by all designers. A clear need was felt for separate consideration of load and deflection data in joint design. This would allow consideration of the likely failure mode to be incorporated during the design stage and for optimum design values for load and deflection, having regard to structural safety, to be chosen.

DISCUSSION

The lack of confirmatory data together with the arbitrary origins of certain design criteria (Harding, 1983) provide unconvincing evidence of the need either to conform with or to enforce the strictures of NZS 3603 with regard to bolted timber connections loaded in shear.

Experimental evidence (Noren, 1951) suggests that washer size may have little effect on the lateral shear strength of joints with the slenderness values (i.e. the ratio of the member thickness to bolt diameter) commonly used in construction (i.e. greater than 4) and the belief that structural failure may be a function of member strength rather than joint strength in a timber structure is also supported (Wood, Cooney and Potter, 1976). Work at the United States Forest Products Laboratory (Wilkinson, 1976) has indicated that joint stiffness may increase under high rates of cyclic loading typical of actual earthquake conditions. Thus, for a given deformation limit a joint may carry considerably more load during an earthquake than under static conditions.

These are only indications of an undue conservatism in the building code and do not take into account any possible adverse effects of reduced end and edge spacings.

At present, breaches of the building code commonly occur with regard to minimum dimensions of bolt-hole diameter, distance to loaded ends or edges and washer sizes. The most flagrant violations occur with the widespread use of coach-bolts, - implicitly forbidden in structural applications by section 4.4.1.2 of NZS 3603 which specifies washers under both bolt-head and nut of load-bearing bolts.

Bolts available in New Zealand, manufactured to tolerances allowed in AS 1111-1972 : ISO Metric Hexagon Bolts and Screws, further complicate implementation of code provisions regarding bolt-hole diameter. Variations in bolt diameter approximate the maximum leeway of 1.5 mm allowed by NZS 3603 and strict conformance with the code is barely feasible without individual measurement of each bolt. If the bolt diameter referred to in NZS 3603 is assumed to be the nominal diameter (although the code does not state this) the definition of maximum allowable hole size is thus shown to be somewhat crude, - $D + (1.5 \pm 50\%)$, - implying acceptable diameters in excess of $D + 2$ mm.

Comments concerning ranges of "to or three millimetres" in nominal bolt diameter, often heard and used in part as reason for enlarged bolt-hole sizes, tended to lay the blame on variations in thickness of the zinc coatings. A more likely reason may be the

somewhat blurred distinction between coach-bolts of nominal and reduced-shank diameters. Certainly some suppliers were not aware of two bolt sizes available under the same name, and purchasers of coach-bolts may perhaps have received either on different occasions. Use of these reduced-shank bolts may be cause for concern with its resultant, possibly unforeseen, losses in joint strength. A similar comment may be made regarding the use of threaded rods, in effect a form of reduced-shank bolt.

Section 22.2 of NZS 3602 : 1975, the Code of Practice for Specifying Timber and Wood-Based Products for Use in Building, recommends the use of galvanized or non-ferrous fastenings for timbers exposed to the weather or in conditions of high humidity, mention is also made of a corrosion hazard for metal connectors used with multisalt-treated timbers specified for such situations.

The results of a previous BRANZ investigation (Whitney, 1977) made with particular reference to pole-frame structures, indicated that hot-dip galvanizing was a minimum requirement for adequate durability, - electroplated zinc, customarily having a thickness only 10% of that applied by hot-dip galvanizing was considered inadequate, - in conditions such as those referred to above. An interesting side effect of preservative treatments such as copper-chromium-arsenic (CCA), - the most widely used in New Zealand when high durability of timber is required, - and others, is that they leave residues which can in some instances enhance the corrosion rates of the metal fasteners in timber at higher (18% plus) moisture contents. Ironically such preservatives enable timbers to be used at moisture contents far above those at which untreated timber would be expected to decay.

The durability requirement for mild steel components laid down in section 2.2 of NZS 3604 : 1981, the Code of Practice for Light Timber Frame Buildings Not Requiring Specific Design, reiterates the recommendation of NZS 3602, in somewhat stronger terms, by specifying that such components, including bolts, nuts and washers, exposed to the weather or in any position where dampness or condensation may occur shall be hot-dip galvanized. The foundation applications in which the majority of bolted connections noted in this survey occurred are clearly governed by stipulations specified in NZS 3602 and as such should be galvanized. The use of ungalvanized components, particularly with regard to the uncoated mild-steel bolts preferred in some districts, appears not only a violation of NZS 3604 but possibly a distinct hazard in some instances, regardless of whether or not the joints conform with the requirements of NZS 3603.

The lack of known structural failures attributable to usage of non-conforming connections is perhaps indication of an undue conservatism in the code; although it is possible that these joints have yet to be subjected to their full design loadings. At present no known data exists to confirm that such joints will adequately cope with these load conditions or conversely, that they will not. Structures, such as those investigated in the course of this survey, which incorporated bolted timber joints in violation of NZS 3603 seem manifestly capable of withstanding at least moderate loadings induced by wind or seismic action. It is quite possible that there have been situations where partial collapse has occurred and remained unnoticed or, because of the general ease of repairs to timber structures, in cases where actual collapse has not occurred, gone unreported.

CONCLUSIONS

At present several identifiable provisions of NZS 3603 regarding bolted timber joints are wilfully ignored by many builders. These violations seem to occur with the knowledge and acceptance of most building inspectors, engineers and designers. All parties surveyed share similar reservations as to the validity of these provisions and conformance is seldom enforced.

From this it may be inferred that: either practical experience has shown that these provisions are overly conservative or, large numbers of sub-standard, under-designed joint connections have been and are being incorporated in many New Zealand timber-framed structures.

The code provisions are certainly unsatisfactory, based as they are on apparently somewhat arbitrary criteria, but considerable evidence exists to suggest that if they err, at least it is on the side of caution and in the absence of anything better, provide safe minimum design criteria. Of necessity the industry has tacitly substituted another quite arbitrary system, with equally unknown but apparently lower safety factors. Because there are no established minimum criteria for this system it must, however desirable, be considered even more unsatisfactory.

COMMENT

Effectively the construction side of the industry has imposed its own standards for bolted timber connections. This state of affairs seems likely to continue until adequate data is provided to enable preparation of a new set of properly researched code requirements which can be introduced and enforced with conviction.

That any provisions in a New Zealand Standard should have inspired so little confidence among their users is unfortunate. That provisions in any New Zealand Standard, which relate to safety, should have been allowed to go by default for so long that they now apparently need to be justified before conformance will be either obtained or enforced is clearly unacceptable.

REFERENCES

Standards and Codes

Australian Standard AS 1111 - 1972, ISO Metric Hexagon Bolts and Screws : Standards Association of Australia.

British Standard Code of Practice CP 112 : Part 2 : 1971. The Structural Use of Timber : British Standards Institution.

Canadian Wood Construction WJ4 1977; Connectors and Supports : Canadian Wood Council.

National Design Specification for Stress-Grade Lumber and its Fastenings 1977 : National Forest Products Association, Washington, D.C.

New Zealand Standard. NZS 3602 : 1975, Code of Practice for Specifying Timber and Wood-Based Products for Use in Building: Standards Association of New Zealand.

New Zealand Standard. NZS 3603 : 1981, Code of Practice for Timber Design : Standards Association of New Zealand.

New Zealand Standard. NZS 3604 : 1981, Code of Practice for Light Timber Frame Buildings Not Requiring Specific Design : Standards Association of New Zealand.

General

Harding, N., 1983, Bolted Timber Joints : A Literature Survey : Building Research Association of New Zealand. Research Report R. Wellington.

Noren, B., 1951, Strength of Bolted Wood Joints. Especially the Influence of Washer Size on Strength and Stiffness in Single Shear : Commonwealth Scientific and Industrial Research Organization, Australia, Translation No 9737. (Translated from Svenska Traforskiningsinstitutet, Tratekniska Avdelningen, Meddelande 22B).

Whitney, R.S., 1977, Timber Fasteners and Potential Problems of Corrosion. In Pole Housing Design and Practice: Notes from the seminar held at the University of

Canterbury, May 9 and 10, 1977. University of Canterbury. Christchurch. Also available as Building Research Association of New Zealand Reprint No 10. Judgeford.

Wilkinson, T.L. 1976, Vibrational Loading of Mechanically Fastened Wood Joints: United States Department of Agriculture, Forest Service Research Paper FPL 650.

Wood, J.H., Cooney, R.C. and Potter, S.M., 1976, Cyclic Testing of Connections for Light Timber Construction : Ministry of Works Department, Report No 5-76/12, Structures Laboratory, Central Laboratories, Lower Hutt.

INTERNATIONAL COUNCIL FOR BUILDING RESEARCH STUDIES AND DOCUMENTATION
WORKING COMMISSION W18 - TIMBER STRUCTURES

BOLTED TIMBER JOINTS
DRAFT EXPERIMENTAL WORK PLAN

Building Research Association of New Zealand
New Zealand

LILLEHAMMER
NORWAY
MAY/JUNE 1983

INTERNATIONAL COUNCIL FOR BUILDING RESEARCH STUDIES AND DOCUMENTATION
WORKING COMMISSION W18 - TIMBER STRUCTURES

BOLTED TIMBER JOINTS
DRAFT EXPERIMENTAL WORK PLAN

Building Research Association of New Zealand
New Zealand

LILLEHAMMER
NORWAY
MAY/JUNE 1983

INTERNATIONAL COUNCIL FOR BUILDING RESEARCH STUDIES AND DOCUMENTATION
WORKING COMMISSION W18 - TIMBER STRUCTURES

BOLTED TIMBER JOINTS
DRAFT EXPERIMENTAL WORK PLAN

Building Research Association of New Zealand
New Zealand

LILLEHAMMER
NORWAY
MAY/JUNE 1983

DRAFT EXPERIMENTAL WORK PLAN.

AS AT 15/3/83.

Ref: Timber Joints/Structures Disk

BOLTED TIMBER JOINTS

Introduction

Design loads for bolted timber joints are detailed in the New Zealand timber design code NZS 3503:1981, the Code of Practice for Timber Design. These design loads are restricted in their application because:

- a) Large (50 x 50 x 3 mm) washers must be used under the head and nut of every bolt.
- b) Minimum end and edge distances for bolt holes are specified and the permissible design load becomes zero immediately below these minima.
- c) Load/deflection data is not available for deflection design.
- d) Ultimate loads are not available for strength design.

In practical design situations these provisions are often highly inconvenient to fulfil and many bolted connections are made which, of necessity, violate some code rules. These connections clearly have some strength but such violations mean a code allowable bolt load of zero.

The code is based on published information which has been sighted but it is believed that testing is required to provide additional information.

Objectives

- a) To determine design loads for bolted joints where the more commonly available (and used) smaller engineering washers are used, and in the case of the heads of coach bolts where no washers are used.
- b) To determine design loads for bolted joints where reduced edge and end distances are used.
- c) To determine load/deflection curves for bolted joints.

- d) To determine the ultimate strengths of bolted joints.
- e) To determine the effect of rate and type of loading on bolted joints in relation to wind and seismic loading.
- f) To promulgate this information for use by designers and acceptance by local authorities for compliance with the timber design by-law.

Previous Work

This is discussed in a report on a literature survey (Harding, 1983a) which formed a preliminary stage to this research programme. In general this highlighted the lack of detailed and replicated information available on the subjects proposed for investigation. It also revealed the somewhat arbitrary origins of certain design criteria in current use, which may therefore be suspect in practice.

A brief survey of current construction practice and usage of components with regard to bolted timber joints was also carried out to provide sufficient data to enable the emphasis of the following experimental work to be placed such as to yield results of practical application and benefit to the industry. This survey (Harding, 1983b) indicated two further aspects for inclusion in the test programme:

a) Undersized bolts.

These appeared in two forms, 'reduced shank' coach bolts, some 1.5-2 mm less in shank diameter than the nominal sized bolts, and threaded rods.

b) Bolt-hole size.

The maximum tolerance of 1.5 mm allowed by NZS 2603 was considered impractical and generally disregarded. In practice hole tolerances are rarely less than 3 mm in excess of bolt-shank diameter.

References

Australian Standard. A111-1972, ISO Metric Hexagon Bolts and Screws: Standards Association of Australia.

Harding, N., 1983a, Bolted Timber Joints: A Literature Survey: Building Research Association of New Zealand. Research Report R. Wellington.

Harding, N., 1983 b, Bolted Timber Joints: Practical Aspects of Construction and Design: A Survey: Building Research Association of New Zealand. Unpublished Report UP 185. Wellington.

New Zealand Standard. NZS 3603: 1981, Code of Practice for Timber Design: Standards Association of New Zealand.

Test Details

The numerous variables which affect the behaviour of bolted joints precludes a totally comprehensive test programme including all possible combinations of these parameters. The planned experimental work will therefore be limited to areas relevant to current construction practice.

Two separate issues are under investigation: the effect of several factors on the behaviour of bolted timber joints loaded either parallel or perpendicular to the grain. These will be kept as two separate experimental series. Each series will be further subdivided: those tested green (above 30% M.C.) and those tested dry (below 18% M.C.). Both sub-series will be constructed using green timber.

The factorial design method will be used for subsequent statistical analysis of the test data obtained. To simplify analysis, the experimental work will be divided into three phases: phase I will contain only two levels of each variable under consideration - in general the limiting value as given by NZS 3603 and a reasonably extreme value. In the case of slenderness ratio, the values of 1:4 and 1:8 as the minimum and maximum normally applied in practice to bolted timber joints in single shear. From the results of these tests, some estimate of the linear part of the effects and interactions should be obtained.

Further testing - phase II - will be designed in the light of these results and will be intended to obtain information at intermediate values of the factors considered in phase I. Variations in bolt size/type may be introduced at this stage.

Phase III testing will consider the effects of variations in rate and type of loading.

Parameters to be investigated

Phase I

<u>Constants:</u>	Bolt size: 12 mm hexagon-head.
Loading:	Monotonic, two member single shear, laterally loaded in tension.
Testing Speed:	2 mm/min
Groups Materials:	Radiata pine, No 1 framing grade (new crop) two sources, chosen to cover density range for this timber.
Moisture content:	Assembled green (above 30% M.C.), testing dry (below 18% M.C.) Assembled and tested green.
Loading direction:	Parallel to grain and perpendicular to grain.

Factors

- A. Hole size: 13.5 mm, 15 mm.
- B. Head type: 50 x 50 x 3 mm washer, 32d x 3 mm washer.
- C. Joint Slenderness ration: 1:4, 1:8.
- D. Edge distance: 4D, 2D perpendicular to grain constant 2D parallel to grain.
- E. End distance: 4D, 2.5D perpendicular to grain. 8D, 3D parallel to grain.

A total of sixty-four test specimens for each timber type under investigation.

Phase II

Loading type and rate: as for phase I.

Loading direction and moisture content groups: as for phase I.

Materials: as indicated by phase I data.

Bolt type: 12 m Hexagon-head, threaded rod, coach bolt.

Factors A-E: values intermediate to phase I as indicated from previous data.

Phase III

Undefined: Comparison of NZS 3603 joints with joints designed from phase I and II data. Loading to be high rate monotonic and/or cyclic to apply acceptable simulation of seismic loading, impact and wind loadings.

Recording of Test data.

Load/deflection data to be recorded continuously during test up to deflections of at least 30 mm relative movement, measured at the bolt, unless ultimate load has already been achieved. Yield point and proportional limit determined from data. Note type of failure and whether bolt was bent. After test, slices to be cut from specimen to determine wood density and moisture content at time of test.

Test joint designs.

These are shown in Figure 1. A detailed schedule of phase I test joints is given in tables 1 and 2.

Assembly

All joints to be assembled with nuts tightened to known constant torque. Nuts to be loosened and re-tightened finger-tight immediately prior to test.

Conditioning

All joints to be assembled green (i.e. at 30% M.C. or above). Joints to be tested whilst green tested immediately after assembly or stored in conditioning chamber to maintain constant M.C. until test.

Joints to be tested when dry stored under cover - preferably in a constant climate chamber until desired moisture content (i.e. 18% M.C. or below), as determined by moisture meter, is obtained.

Test Sequence

The wet tested joints, require no 'seasoning' period and will therefore be tested before they dry in order to expedite planning of phase II testing. The joints do not need to be tested in any sequence but, if possible, all joints of a sub-series will be tested together.

Table 1 Schedule of Test Joints.

Phase I

Series No	Factor Code	Bolt type (2 unid)	Bolt hole size	Washer size (mm)	Slenderness ratio	Loading direction w.r.t. grain	Distance (mm)		M.C.		Material	Test Speed	Test Type
							End	Edge	Ass.	Test			
	0	Hex-head	13.5	50x50	1:8	perp	40	40				2 mm/min	static
	AB	"	15	50x50	1:4	"	40	40					
	AC	"	13.5	320	1:4	"	40	40					
	AD	"	13.5	50x50	1:4	"	40	20					
	AE	"	13.5	50x50	1:4	"	2.50	40					
	BC	"	15	320	1:8	"	40	40					
	BD	"	15	50x50	1:8	"	40	20					
	BE	"	15	50x50	1:8	"	2.50	40					
	CD	"	13.5	320	1:8	"	40	20					
	CE	"	13.5	320	1:8	"	2.50	40					
	DE	"	13.5	50x50	1:8	"	2.50	20					
	ABCD	"	15	320	1:4	"	40	20	Green ① and ②	Green ① dry ②	series ① and ② for each material		
	ABCDE	"	15	50x50	1:4	"	2.50	20					
	ABCE	"	15	320	1:4	"	2.50	40					
	ACDE	"	13.5	320	1:4	"	2.50	20					
	BCDE	"	16	320	1:8	"	2.50	20					

① Tested green
 Duplicate series ② tested dry

$\frac{L}{2}$

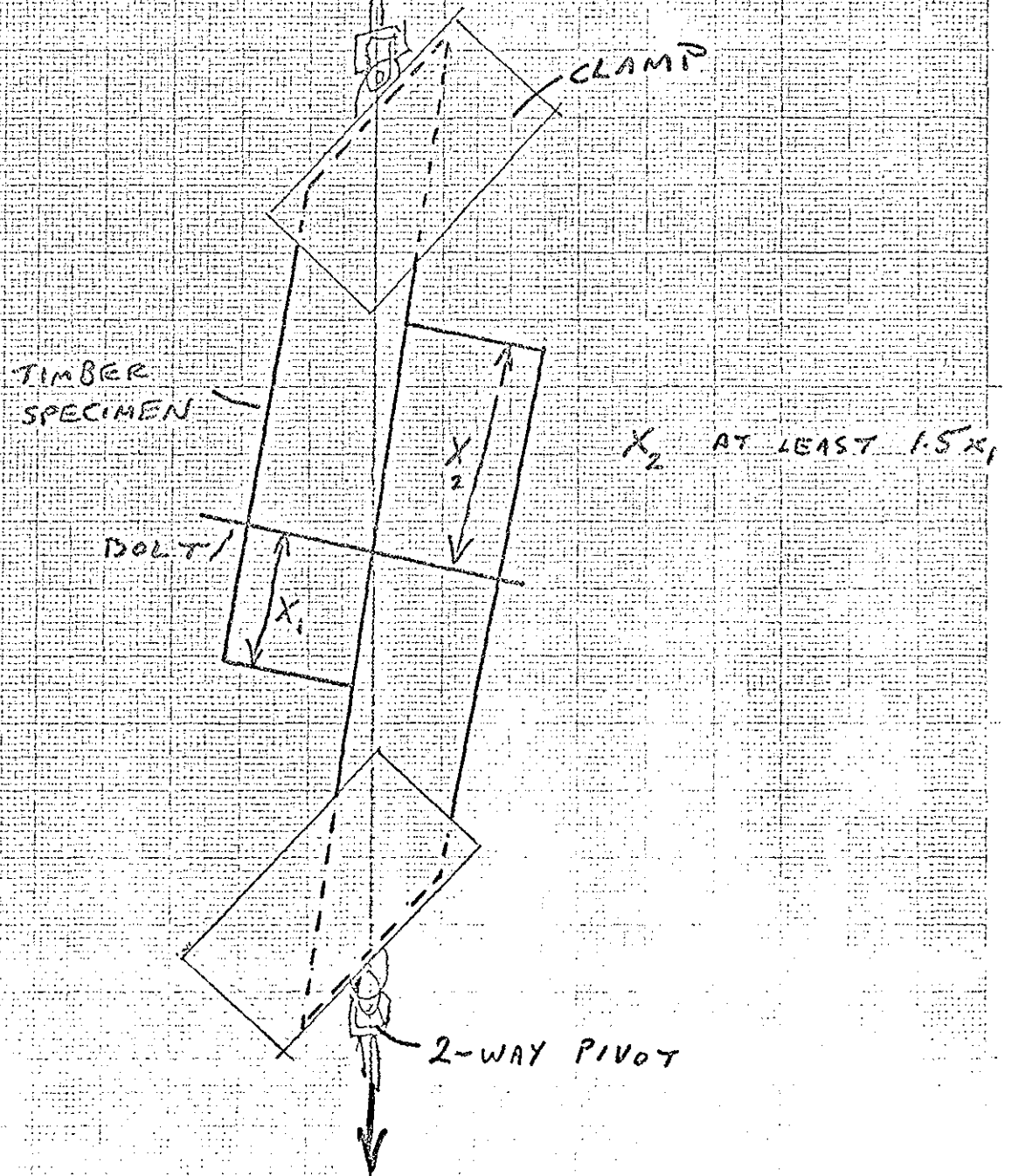

INTERNATIONAL COUNCIL FOR BUILDING RESEARCH STUDIES AND DOCUMENTATION

WORKING COMMISSION W18 - TIMBER STRUCTURES

EFFECT OF TEST PIECE SIZE
ON PANEL BENDING PROPERTIES

by

P W Post

American Plywood Association
USA

LILLEHAMMER

NORWAY

MAY/JUNE 1983

INTERNATIONAL COUNCIL FOR BUILDING RESEARCH STUDIES AND DOCUMENTATION

WORKING COMMISSION W18 - TIMBER STRUCTURES

EFFECT OF TEST PIECE SIZE
ON PANEL BENDING PROPERTIES

by

P W Post

American Plywood Association
USA

LILLEHAMMER

NORWAY

MAY/JUNE 1983

INTERNATIONAL COUNCIL FOR BUILDING RESEARCH STUDIES AND DOCUMENTATION

WORKING COMMISSION W18 - TIMBER STRUCTURES

EFFECT OF TEST PIECE SIZE
ON PANEL BENDING PROPERTIES

by

P W Post

American Plywood Association
USA

LILLEHAMMER

NORWAY

MAY/JUNE 1983

Effect of Test Piece Size on Panel Bending Properties

by P. W. Post

INTRODUCTION

Many structural panel products suitable for building construction are now available. These include plywood, particleboard, hardboard, waferboard, oriented strand board, cement-bonded board and others. Normally these panels are used full size in a building or are cut into relatively large pieces. Roof sheathing, wall sheathing, floors, shear walls, diaphragms, stressed-skin panels, and webs of I beams or box beams are examples. A notable exception is gusset plates of trusses which are usually small in size and highly stressed. If narrow strips are tested to determine engineering properties, then the relationship of small specimens to full panels needs to be understood for the important properties. For a variable material such as softwood plywood or the various reconstituted boards, these relationships are more complex than one might suspect.

BACKGROUND

Prior to 1958 in North America and until recently in Scandinavia and Europe, mechanical properties of panel materials including plywood were evaluated by testing small specimens. Bending specimens were usually center loaded and 50 to 75mm in width. Tension and compression specimens were even smaller and shear tests possessed an area of only a few hundred square millimeters. The small methods previously covered in ASTM D805 and now covered individually in ASTM D2718, D2719, D3043, D3044, D3500, D3501, for plywood and D1037 for particleboard and other reconstituted boards are North American examples. A European example is the various German DIN Standards for plywood. Small methods work fairly well for panel materials showing little variation within the panel. They were the basis for the excellent design information developed by the U. S. Forest Products Laboratory for design of aircraft with plywood.

In the forties and late fifties in North America the softwood plywood industry recognized an enormous market for its product in building construction. It also recognized that limitations would be placed on access to those markets by building codes and other regulatory agencies if its use recommendations were not backed up by good information on panel properties. However, the plywood grades the industry proposed to use were of much lower quality than aircraft plywood. Knots and knotholes and the associated distorted grain could reduce bending and tension by more than 50 percent; core gaps introduced in the manufacturing process could reduce shear by a like amount. It was concluded almost entirely on the basis of intuition that materials containing such large within-panel variations could be fairly evaluated only by testing large pieces.

Accordingly, equipment for testing full-size panels for bending strength and stiffness was developed and methods for shear, tension and compression using test pieces large enough to determine the effects of knots and distorted grain in a representative manner were adopted. These methods are now included in the ASTM Standards for plywood and the concepts are included in RILEM Recommendation TT2 for plywood. In the U. S. large methods also are being applied to the reconstituted structural panels intended for building construction.

Variation within panel of reconstituted boards is neither as obvious nor as great in magnitude as with sheathing plywood, but is nonetheless present. Within panel coefficients of variation 14 percent for E and 18 percent for strength occur in one oriented strand board. For determining the engineering properties of reconstituted boards a choice can now be made between large and small specimens. That choice can be made in a more rational and less intuitive manner than was the case for plywood twenty years ago.

In this paper we will explore by theory and by experiment some of the considerations relevant to that choice.

Especially pertinent is the manner in which elements such as narrow strips interact to influence the stiffness or load capacity of large pieces or full panels. These interactions can cause large pieces to have greater or lesser properties than small pieces.

Combinations of Elements

For simplicity, elements of a panel may be considered as acting either in a series or parallel combination, although both actually occur in a panel. In the series combination, elements are joined end-to-end in the direction of stress. In a parallel combination, the elements are joined side-by-side across the direction of stress. In the series combination the stress level is the same for all elements, and deformation varies with the E of the elements. In a parallel combination as a combination of strips arranged side-by-side to make up the width of a panel, the deformation tends to be equal and stress varies with the E of the elements.

Strength of a series combination is clearly limited, like links in a chain, by the weakest element.

The modulus of elasticity of a series combination of elements that would predict the elongation of the combination under a given load may be calculated as follows:

$$E_t = \frac{N}{\frac{1}{E_1} + \frac{1}{E_2} + \frac{1}{E_3} + \frac{1}{E_4} \dots + \frac{1}{E_N}}$$

where E_t = apparent E for the series combination, and
 E_n = modulus of elasticity of the nth element
N = number of elements

The degree to which the E_t is reduced from the average E of the individual elements is directly related to the variability in E among the elements. A very close approximation is given by: 1)

$$E_t = \frac{E}{(1 + v^2)}$$

where E = average E of the elements in the series and
 V = coefficient of variation of E of the elements
expressed as a decimal

Thus a series combination of elements having a coefficient of variation of elastic modulus of 14 percent such as might occur in an oriented strand board or waferboard would be reduced from the average of the elements by dividing by 1.0196 or just under 2 percent. A material showing a 20 percent coefficient of variation would be reduced by 4 percent.

To summarize, strength of a series combination is governed by the weakest of the elements and elastic modulus by the average reduced in accordance with the coefficient of variation of the stiffness of the elements. In neither case is the average of the elements an accurate representation of the combination.

Stiffness of a Parallel Combination

Parallel combinations have greater application to panel materials. In the test of a full panel in accordance with ASTM D3043, the side-by-side strip elements are bent to approximately equal curvatures as required by the rigidity of the loading frames and continuity of the panel. Stress levels among the strips may vary depending upon the E of the individual strip.

In the parallel combination it is the load or moment carried by the individual strips that varies with the E of the strip rather than the distortion. The E and load are directly related rather than inversely (as was the case in the series combination). In theory, averaging the E 's of the elements gives the correct E of the combination, assuming negligible effect of plate action such as anticlastic curvature.

However, this result does not agree with experimental evidence. Szabo,²⁾ working with Canadian waferboard, found that tests of full panels produced E values about 22 percent higher than small specimens. Differences were significant and applied regardless of panel direction. This is in agreement with less complete tests conducted at APA. Szabo concluded that the greater stiffness of larger specimens was related to edge effects.

1) Suddarth, S. K., F. E. Woeste, J. T. P. Yao. "Effect of E Variability on the Deflection Behavior of Structures. Forest Products Journal. 25:1 January 1975.

2) Szabo, T. "Flexural Properties of Waferboard." Forintek Canada Corp. Eastern Laboratory, Technical Report 505ER Sept. 1980.

To study this hypothesis further, APA conducted exploratory testing as follows: Two full panels, 16mm thick, one a commercial waferboard, the other a commercial oriented strand board were tested in flexure to determine their modulus of elasticity. Then the tests were repeated a number of times and at each step the number of edges in the entral portion of the panel gaged for deformation was increased by making parallel saw cuts in the panel. At each step the E of the panel was compared to the E of the original uncut panel after correcting for the loss of the saw kerf material. Final strip width was 38mm for 31 cuts.

The panel configuration and loading is shown in Figure 1. The E ratio to the E of the full panel corrected for loss of material of the saw kerfs is shown in Figure 2 related to the number of edges per 300mm of panel width. By using this variable instead of strip width, the E loss is nearly linearly related to edges per foot of panel width.

The ratio at 75mm strip width (8 enges per 30 mm) is .89 for waferboard and about .95 for oriented strand board. For waferboard, the effect of edges

accounts for about half the 22 percent difference between large and small specimens obtained by Szabo. The effect of number of edges appears to be quite different for the two panel types suggesting that differences between test methods may depend upon the elastic properties of the panel in the two directions and poissons ratios.

A full panel is forced to deform as a unit and individual elements are not free to respond independently of the whole panel. As the panel is cut into smaller and smaller pieces the stiffening effect of these interactions is lost and a reduced E results. Anticlastic curvature which depends for its effect on width/span ratio is substantially reduced.

No attempt has been made to theoretically study this effect. Again, the average is found experimentally to be considerably in error. More sophisticated theory than applied here might agree better with these experimental results.

Strength of Parallel Combinations

The strenth of a parallel combination of widely varying elements has been of much interest because of its application to softwood plywood with knots, knot-holes and distorted grain. The computation procedure developed for plywood has equal application to other panel materials and helps explain experimentally observed differences between large and small specimens for these materials.

The procedure is illustrated here using a plywood example in which the 1200mm panel width is divided into 16 strips 75mm wide. Strength of 71 panels was determined experimentally by testing them as full panels after the strength of the individual 16 strips was estimated by considering the slope of grain, knots and other strength-reducing factors. Strength is expressed on a relative scale of 0 to 100 with 100 representing the strength of clear, straight-grained plywood.

The first attempt at calculating the strength of the panel from the 16 sections was the intuitively obvious one of averaging the 16 values. The result is shown in Figure 3. Predicted strength is erratic and almost always too high.

Observation of the large panels as they were tested provided some indications of the source of the errors. Areas of lowest strength, usually having distorted grain associated with knots and knotholes, often broke before the maximum moment for the panel was reached. After breaking, these areas contributed little or nothing to the moment carry capacity of the panel. This fact helps explain why the experimental ratios are lower than the average of the 16 estimated ratios.

Whatever the method used to combine the 16 individual ratios, it appeared necessary to consider the sequence of failure. The procedure that was devised can best be explained by considering an example of an actual plywood panel. Figure 4 graphs the 16 ratios as they occur across the width of the panel. The average ratio is 65.1 percent. The sequence of failure is most easily seen by arranging the sections in increasing order from left to right as shown in the stair-step pattern of Figure 5. As the full panel is stressed to the level of the lowest section, the moment sustained is in proportion to the area below the lowest section. As the lowest strength section (27 percent) breaks, its contribution to moment is lost and the moment is sustained by the remaining 15 sections. The next lowest section is at a 28 percent ratio which for the remaining 15 sections gives a ratio of only 26.2 percent. The next lowest ratio applicable to 14 sections is 30 percent, giving a ratio of 26.2 percent. Since the moment limited by the second and third lowest sections is slightly less than the first lowest, breakage is likely to cascade rapidly through these first three sections. The fourth lowest section, however, has a ratio of 50 percent which applied to the remaining 13 sections gives an overall ratio of 40.6 percent, a substantial increase. When this moment level for the panel is reached and the fourth lowest section breaks, it is seen that with each successive section the area and corresponding moment capacity is either almost the same or lower. Therefore, the area governed by the fourth lowest section, indicated by the dashed lines as Area A, represents the moment capacity of the panel. Panel moment determined by the following sections decreases slowly and then more rapidly. In theory, breakage of the fourth lowest section should precipitate a cascade failure of the rest of the panel. But small variations could mean that failure progresses section by section as the panel continues to be bent, sustaining slightly lower moment at each step but absorbing considerable energy. Finally, failure cascades rapidly as moment capacity drops at the eighth lowest and following section.

Assuming all actions at 100 percent ratio and the entire area within the rectangle taken as 100 percent, the rectangle may be subdivided into areas that relate to panel moment capacity as follows:

Area A represents the moment capacity actually obtainable in test, namely 40.6 percent.

Area B represents the moment capacity lost by low strength sections breaking before maximum moment is attained and therefore not contributing, in this case 5.3 percent.

Area C represents the portion of moment capacity of high strength sections whose strength capacity could not be utilized due to the failure sequence.

Area D is area above and to the left of the stair-step line and corresponds to the actual moment loss due to strength reducing features without considering failure sequence.

Area A + B + C represents the moment if all sections could be utilized to their full capacity. This is assumed when the 16 sections are averaged, namely 60.5 percent.

Figures 6A and 6B provide examples of similar charts for panels having high and low strength ratios respectively.

Figures 6C and 6D are charts for panels having strength ratios more typical of C and D veneers.

Figure 7 shows the relationship of estimated to observed strength ratios shown in Figure 3, but in this case the estimated ratio was obtained by considering the sequence of failure as shown in Figures 5 and 6. The improvement in the relationship is substantial, though the correlation is far from perfect. Much of the scatter is probably related to inaccuracy in estimating the strength of strips. Thus a much closer representation of strength is obtained by considering failure sequence.

The foregoing illustrates the difficulties encountered when one attempts to predict the bending performance of full panels or large pieces from tests of small strips. We have not experimented with size relationships for other properties. Since bending strength is closely related to tensile strength of the tension face, the effect of test piece size is likely to be similar but less pronounced in tension in the plane of the panel. Effect of test piece size on compression and shear has not been studied experimentally. Experience with bending suggests that caution is in order.

In summary, the relationships between results of tests using different sizes of specimens is much more complex than one would intuitively suppose. Therefore, the most reliable data for use in the engineering design of buildings is obtained on test pieces of size comparable to those in actual use. Normally these are of large size or full panels, but exceptions such as truss gussets do exist.

The interaction of small elements of large panels can cause large pieces to have either higher or lower properties, depending upon the property. Within-panel variability greatly influences the magnitude of differences. Within-panel variability of reconstituted boards is significant though less obvious than for construction grades of plywood. It is recommended that for purposes of developing engineering design data the large methods developed for plywood be applied to other reconstituted wood panels as well. Large plywood methods are being incorporated in RILEM recommendation 3TT. They can be easily extended to other panel products.

PWP:ram
June 1983

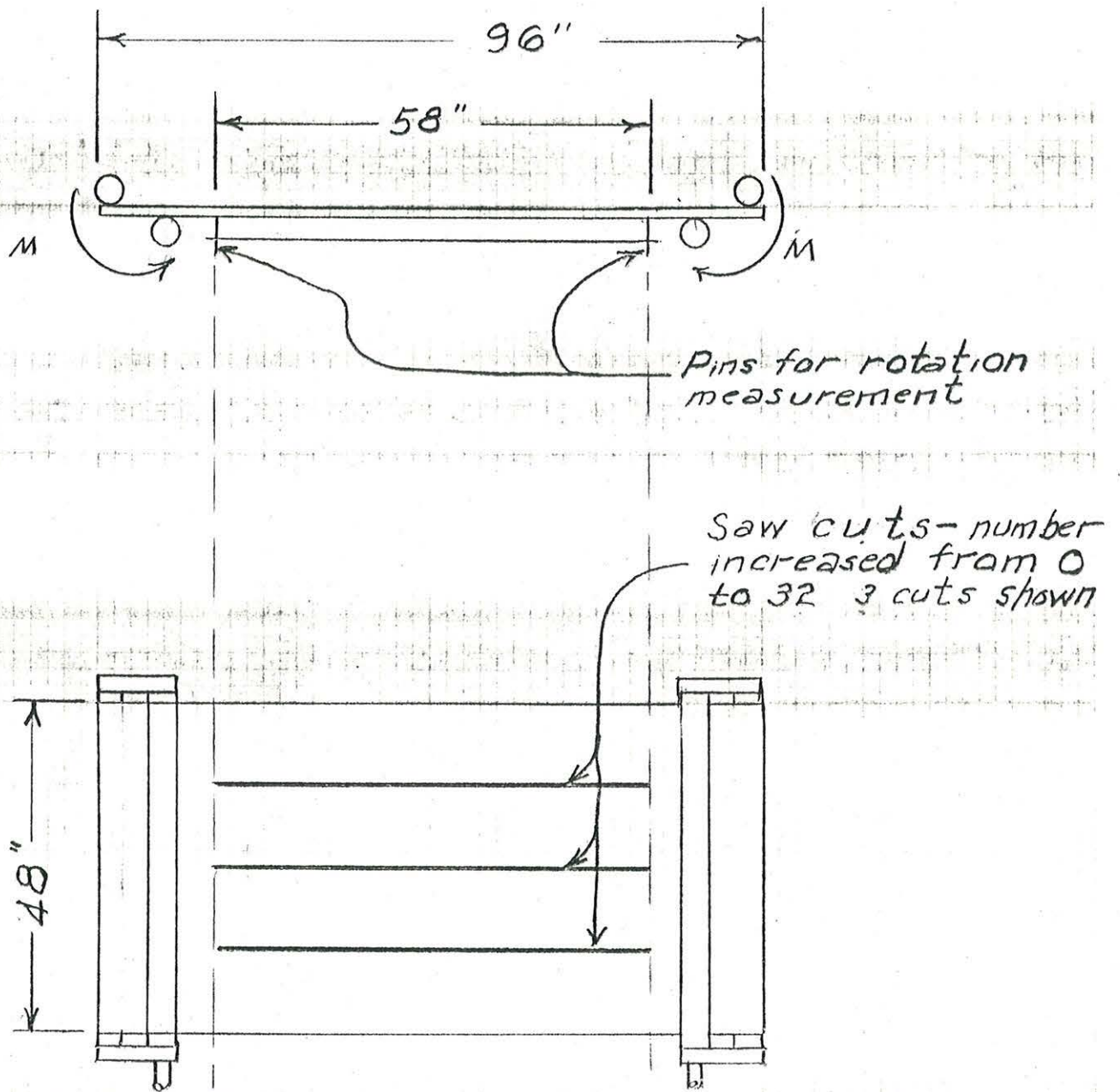

Figure 1. Layout and loading of test panels used to evaluate edge effects on bending stiffness.

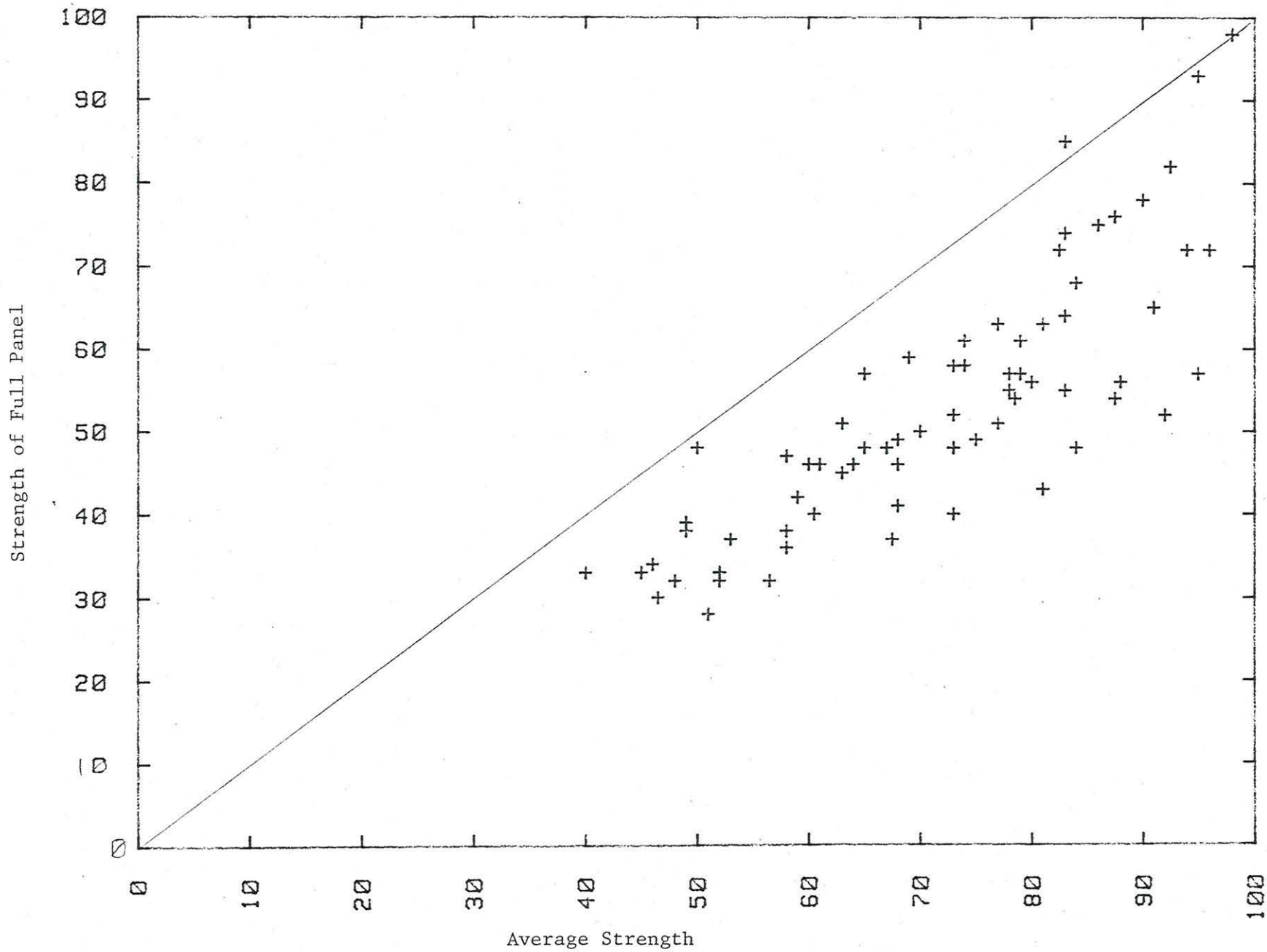

Figure 3. Relationship of average strength of strips to test strength of full panel.

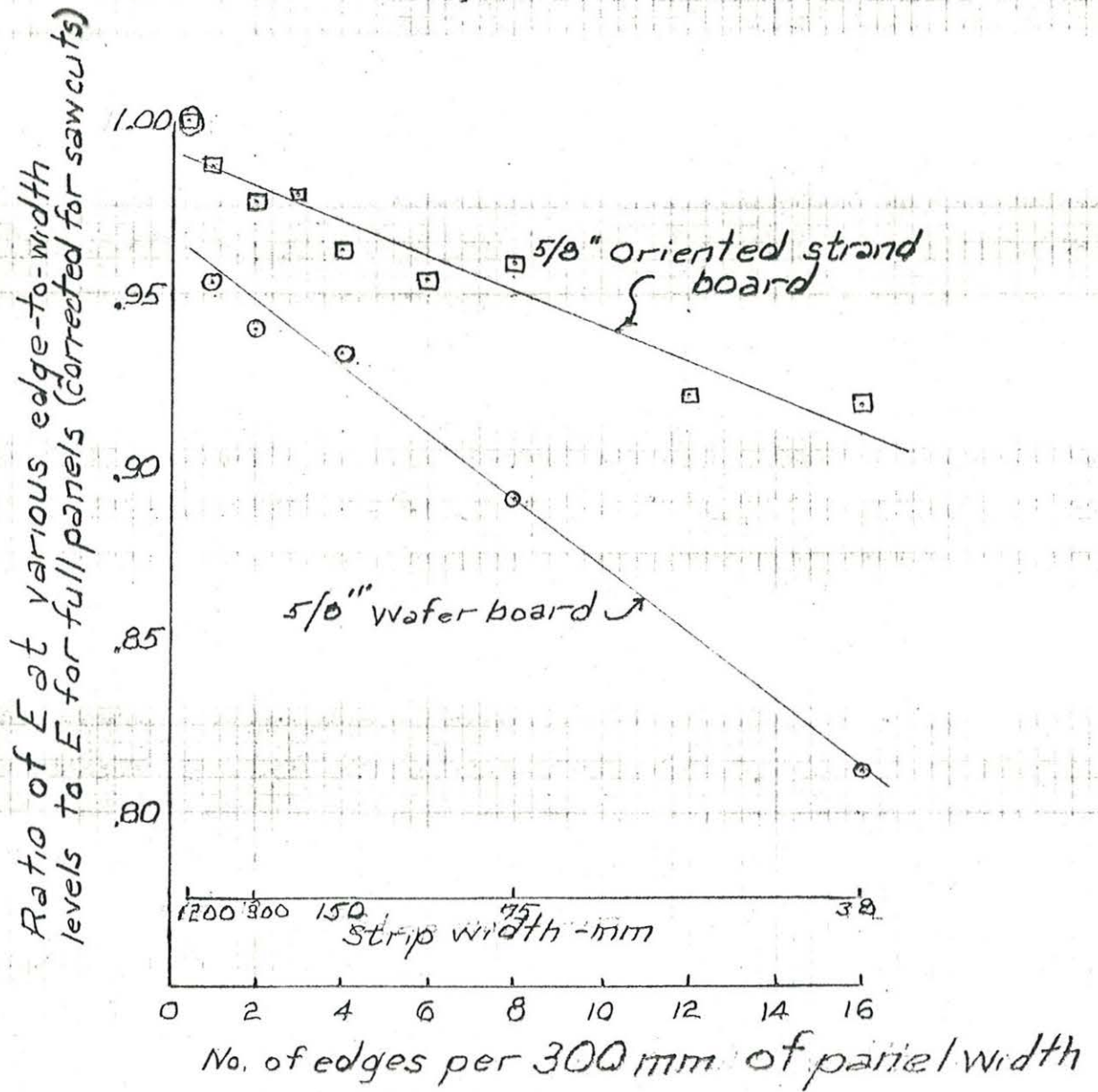

Figure 2. Edge effects on bending stiffness of two kinds of particleboard.

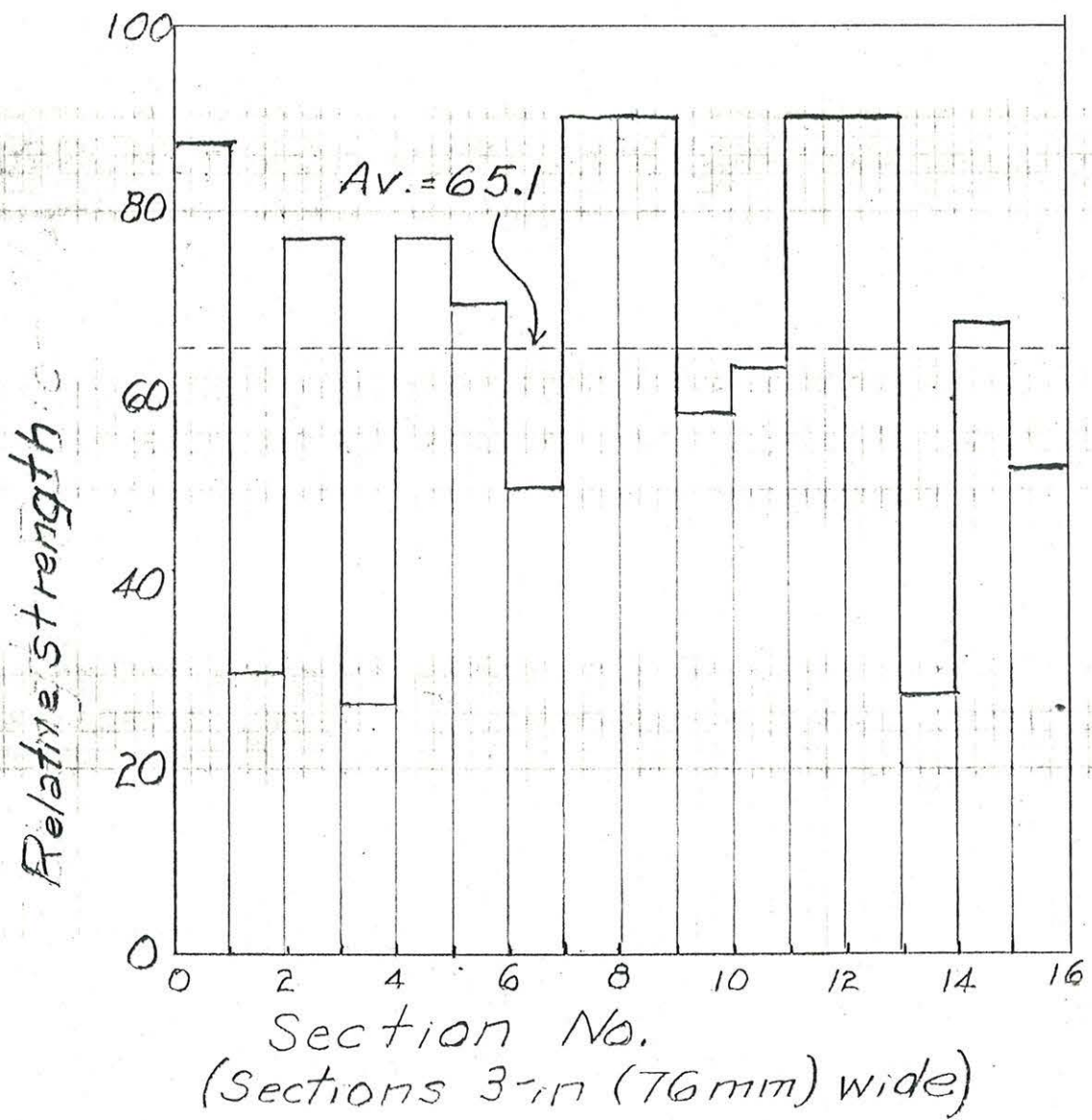

Figure 4. Strength of 16 sections across the 1200 mm width of plywood panel.

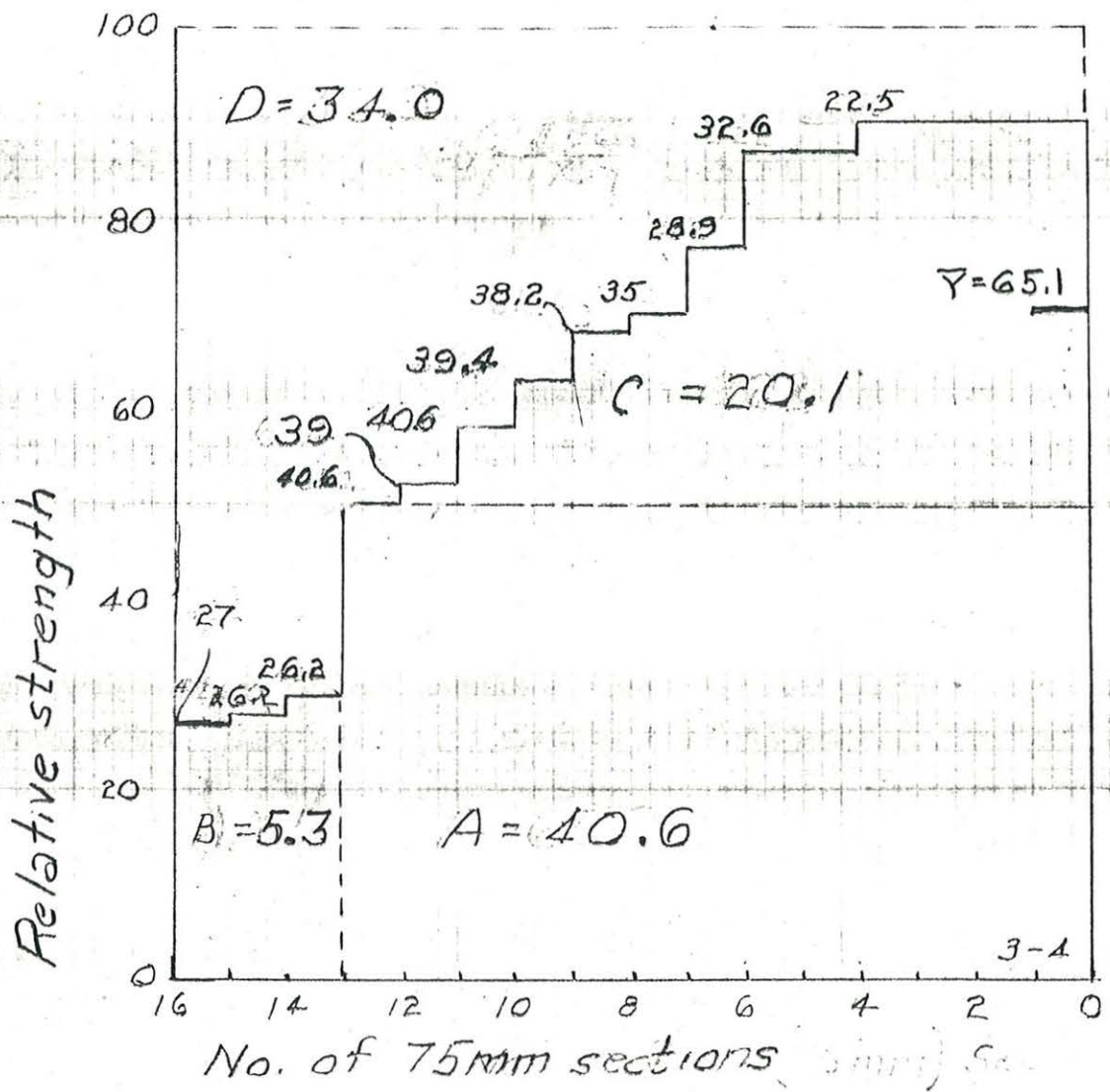

Figure 5. Strength of sections in Figure 4 arranged in ascending order. Number at each step is the area below and to the right of each step.

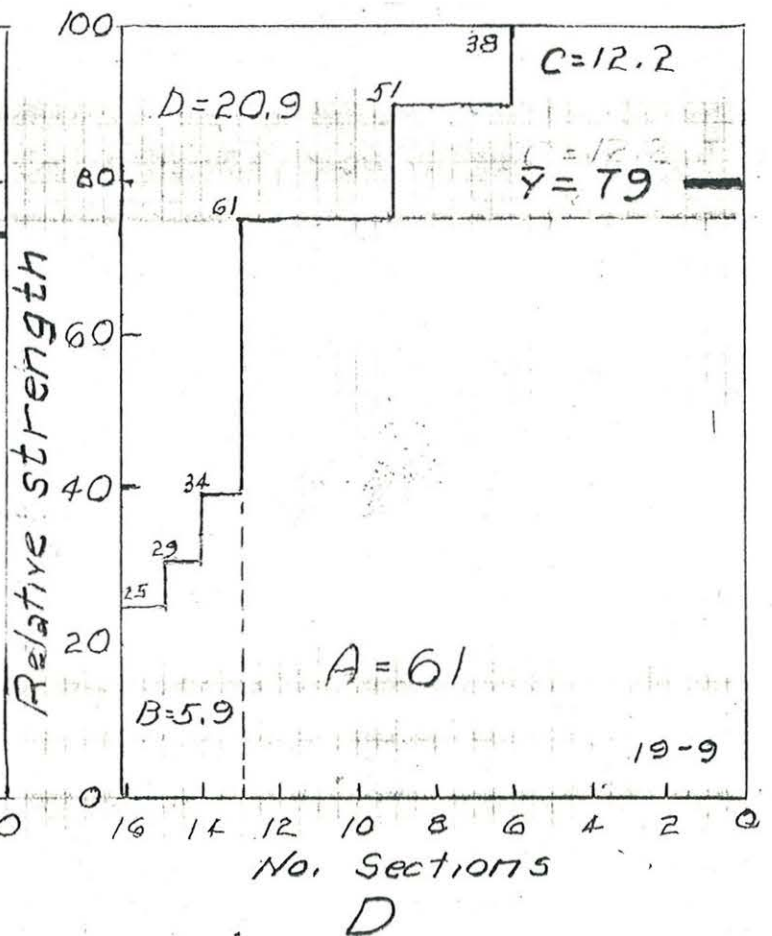
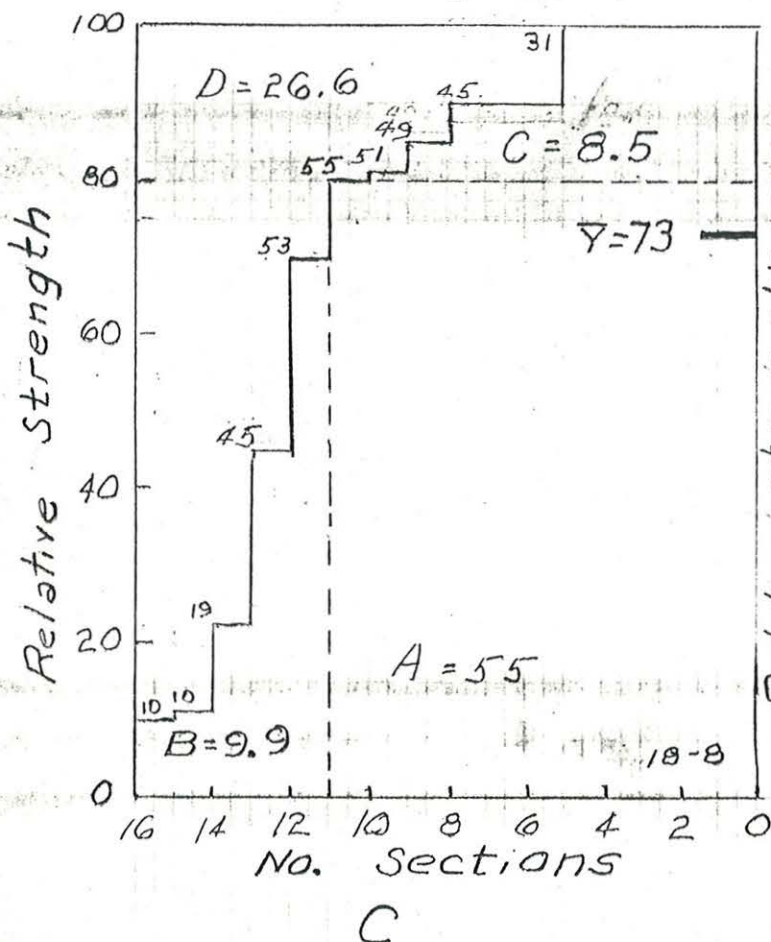
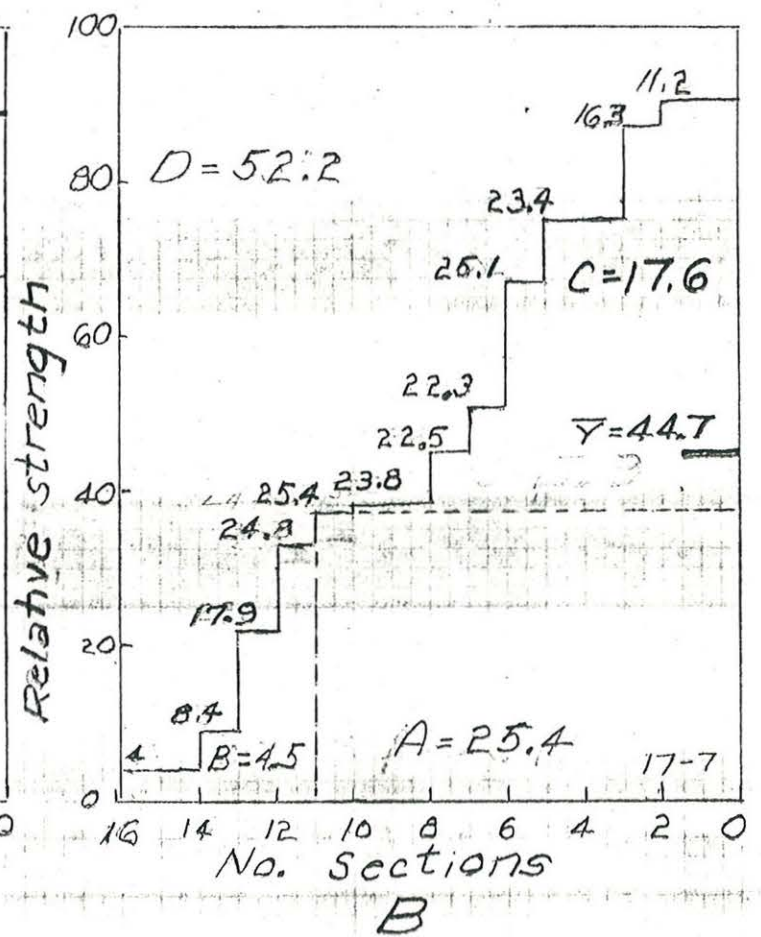
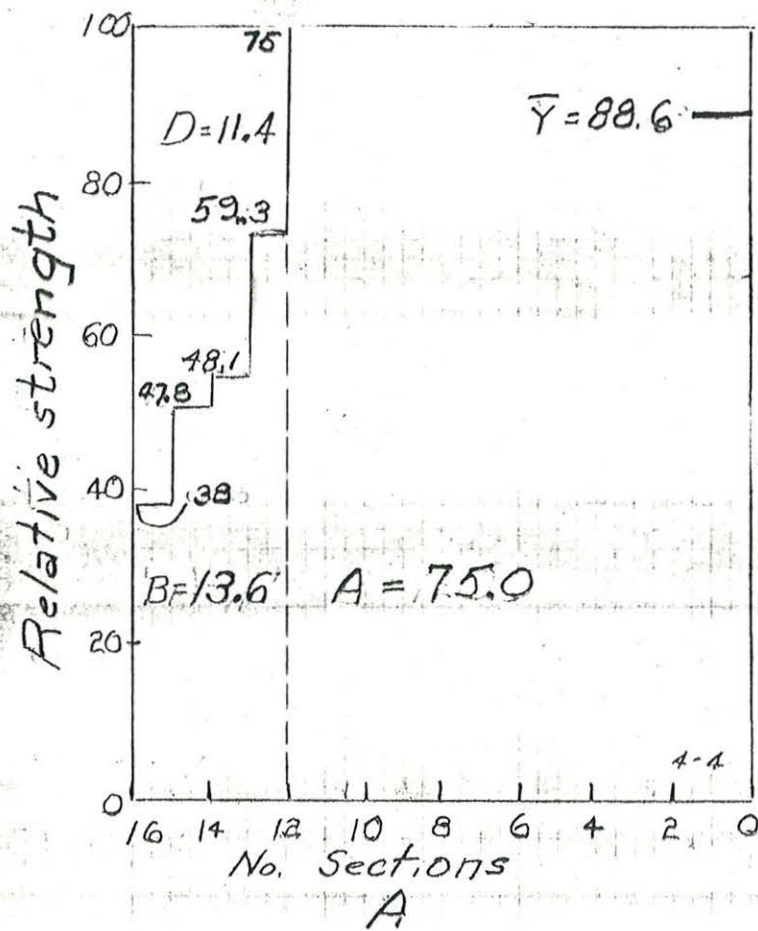

Figure 6. Failure sequence charts for high and low strength plywood panels (A&B) and typical panels (C&D).

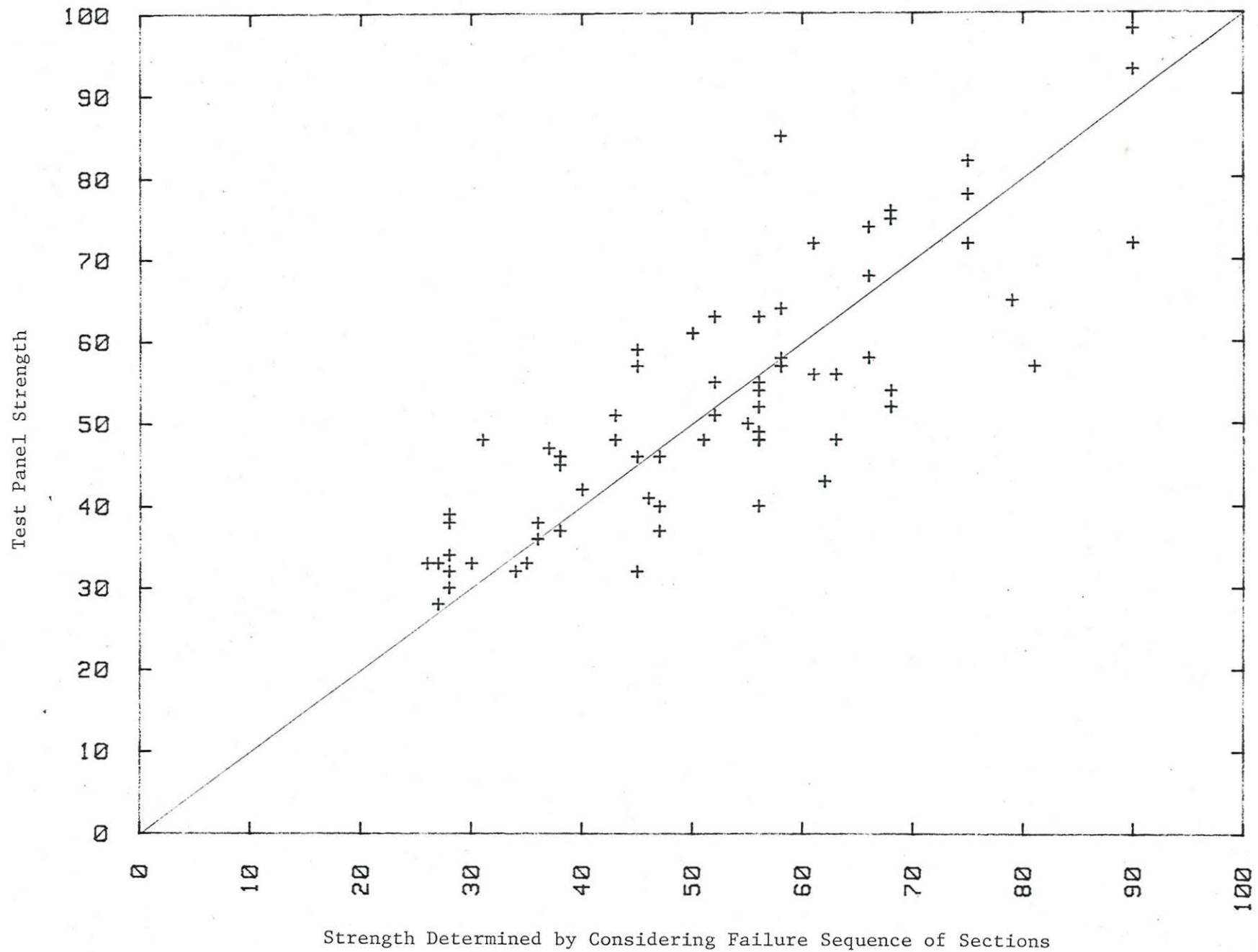

Figure 7. Relationship of estimated to observed strength ratio when estimated ratio considers failure sequence.

INTERNATIONAL COUNCIL FOR BUILDING RESEARCH STUDIES AND DOCUMENTATION

WORKING COMMISSION W18 - TIMBER STRUCTURES

FULL-SCALE TESTS ON TIMBER FINK TRUSSES
MADE FROM IRISH GROWN SITKA SPRUCE

by

V Picardo

Forest Products Department
Institute for Industrial Research and Standards
Ireland

LILLEHAMMER

NORWAY

MAY/JUNE 1983

INTERNATIONAL COUNCIL FOR BUILDING RESEARCH STUDIES AND DOCUMENTATION

WORKING COMMISSION W18 - TIMBER STRUCTURES

FULL-SCALE TESTS ON TIMBER FINK TRUSSES
MADE FROM IRISH GROWN SITKA SPRUCE

by

V Picardo

Forest Products Department
Institute for Industrial Research and Standards
Ireland

LILLEHAMMER

NORWAY

MAY/JUNE 1983

INTERNATIONAL COUNCIL FOR BUILDING RESEARCH STUDIES AND DOCUMENTATION

WORKING COMMISSION W18 - TIMBER STRUCTURES

FULL-SCALE TESTS ON TIMBER FINK TRUSSES
MADE FROM IRISH GROWN SITKA SPRUCE

by

V Picardo

Forest Products Department
Institute for Industrial Research and Standards
Ireland

LILLEHAMMER

NORWAY

MAY/JUNE 1983

SCOPE

Full size tests have been carried out on fifty eight trusses of the Fink configuration using home-grown (Irish) Sitka spruce timber. The timber was of the M75 grade. Metal plate fasteners with integral teeth were used at all joints using the sizes recommended by the plate manufacturers. Forty eight of the trusses were fabricated to the limiting spans for a higher Species Group (S2 - M75) published in I.S. 193P : 1978. Except for three trusses all passed the acceptance criteria set in the Irish Standard. The results obtained from the tests are not included in this paper. Only a brief summary of some of the analyses is shown in the tables at the end of the paper. On the results obtained new limiting spans were proposed for Fink trusses made from home-grown timber.

1.0 INVESTIGATION

1.1 Selection of Species

Roughly 95% of the trees grown in Ireland in the last 60 years belong to the softwood group of species, of which Sitka spruce, Norway spruce and Lodgepole pine are the most predominant. The percentages of each species grown in Irish forests vary from year to year but a recent estimate obtained from the Forest and Wildlife Service suggest the following distribution.

Sitka spruce	44%
Norway spruce	19%
Lodgepole pine	12%
Larch	9%
Douglas fir	7%
Others	2%

The percentages given above refer to the volume of timber in trees with a top diameter of at least 140 mm.

As Sitka spruce was found to be by far the most predominant species it was chosen as the species to use in this project. Statistics available from the Forest & Wildlife Service also indicate that Sitka spruce will, in fact, constitute about 75% of the home grown timbers available for constructional purposes in the next decade. Of the five species stated above Sitka spruce has also the lowest published strength values. The selection of Sitka spruce, therefore, served two purposes:

- (i) the tests would show whether Sitka spruce could be used to published span limits.
- (ii) by inference the other species would have at least the same limiting spans.

1.2 Selection of Pitches, Section Sizes and Spans.

1.2.1 Pitches.

The pitches selected were 17.5° , 22.5° and 30° . There were two reasons for selection of these three pitches

- (a) They are the most commonly used,
- (b) The author felt that they were sufficient to enable interpolation for intermediate pitches.

1.2.2 Timber Sizes and Grade.

The selection of section sizes was limited to those that were most commonly used and which are covered by the Irish Standard. The required timber thickness was 34 mm throughout and the specified depths were 72 mm, 97 mm, 112 mm or 120 mm. All the web members were 72 x 34 mm.

The timber was graded to the M75 grade in a Plessey Computermatic grading machine.

1.2.3 Test Spans.

In the absence of any reliable theoretical design method as a starting point the limiting spans given in Table 3 of IS 193P : 1978 for M75 - S2 timber were used. Table 1 shows the various spans and section sizes tested.

Phase I: For each of the three pitches there were four groups of trusses using the same four section sizes in the ceiling tie and rafter members. The limiting span chosen was the smaller of the ceiling tie/rafter span for the particular section size. As spans were not available for the 112 x 34 mm size, these were interpolated from Table 3 (IS 193). Two more groups were added to the $22\frac{1}{2}^{\circ}$ and 30° pitches in which 97 x 34 and 112 x 34 section sizes were interchanged in ceiling-tie and rafter members, and the limiting span used in each case was the smaller of the ceiling-tie/rafter span for the 97 x 34 section size. The reason for including the two extra groups was to see whether it is valid to give limiting spans separately for ceiling-tie and rafter sections. Three trusses were tested in each group except in one case where the first two trusses tested had to be disregarded because of malfunction of the recording system.

Phase II: The purpose of this phase of tests was to carry out a limited investigation into the effects of altering the thickness of the timber. Two groups were tested for each of the three pitches. The limiting span used for the first group in each case was the published one for home grown M75 - S3 timber. In the second group the same section size with increased thickness i.e. 97 x 41 mm was used and the limiting span was that for M75 - S2 timber.

1.2.4 Types of Plate.

In Phase I Presslock and Rollock metal plate fasteners were used, while in Phase II Hydro-Nail plates were used. The size of plate used at each joint was obtained from the plate manufacturers' manuals. The truss manufacturers were asked to make no special alterations in fabricating the trusses and all the samples were produced during a normal day run.

1.3 Test Equipment.

All the tests were carried out in a test rig specially built for testing full sized trusses. The rig consisted of two independent cable pulley systems by means of which loads were applied to four equally spaced points on each rafter and six equally spaced points on the ceiling tie. The load points were positioned at the quarter points on each bay.

The ends of the cable threading the pulleys hanging from the ceiling tie were attached at each end to trays on which dead weights could be placed.

The ends of the cable threading the pulleys on the rafters were attached to hand winches at each end.

The ceiling tie and rafter cables were both $\frac{1}{4}$ " diameter 12 strand steel wire cables. Each cable was of one continuous length and independent of each other. The pulleys were all light weight aluminium alloy frictionless pulleys.

The supports were made to resemble as close as possible, actual conditions and consisted of a 100 mm x 50 mm timber wall plate at each support placed on metal plates bearing on electrical load cells. The reaction at each support was measured by means of electrical load cells (two under each support) and deflection measurements were taken by means of electrical displacement transducers at the points shown in Fig. 1. The reactions, total load and deflections were recorded on a chart recorder.

The rafter members were laterally restrained by pivoted radius arms at each load point and 38 x 38 battens between loading points. No lateral restraints were used on the ceiling tie.

The concentrated point load at midspan and tank load were applied on the ceiling tie by means of dead weights placed in trays suspended from the ceiling tie. The tank load was placed as close as possible to the node point in the centre bay of the ceiling tie.

1.4 Test Procedure.

The test procedure was in accordance with that specified in the Provisional Irish Standard 193 P : 1978, Appendix A, Clause A2.

In the 24 hour deflection test, deflection measurements up to design load and during the 24 hour under design load were made without the 0.90 kN point load at midspan of ceiling tie.

In the strength tests all the loads except the concentrated point load at centre span of ceiling tie were increased in proportional increments up to failure. Deflection measurements were taken but were stopped when it was considered unsafe to leave the transducers in place, firstly because of the safety of the personnel who removed the transducers and secondly to prevent damage to the expensive transducers.

1.5 Test Conditions

The design loads and truss spacing used in the computation of the test loads were taken as follows:

Spacing of trusses	600 mm
Width of wall plates	100 mm
Rafter loading:	
Dead load - tiles	0.575 kN/m ² on slope
- felt, battens, etc.	0.11 kN/m ² on slope
Live load - snow	0.75 kN/m ² on plan
Ceiling tie load:	
Dead load	0.25 kN/m ²
Live load	0.25 kN/m ²
Tank load	2.70 kN over 4 trusses
Concentrated point load (midspan) where H exceeded 1.2 m	0.9 kN

2. RESULTS

In all, 23 trusses were tested for long-term deflection. None of the trusses in Phase II were tested for 24 hour deflection, as the purpose of Phase II was to study the effect of increased thickness on strength.

2.1 Deflection/Span Ratio.

The deflections at the end of the 24 hour test were in all cases found to be well within the requirements of the Standard. The deflection/span ratios varied between 0.00224 and 0.000902 which is less than the acceptance ratio of 0.0024. It was also found on examination that the steeper the pitch, the stiffer was the truss and this was reflected in the average ratios worked out for each pitch and shown below

Pitch (Deg)	Deflection/Span Ratio
30	0.00107
22½	0.00138
17½	0.00176

2.2 Midspan/Node Deflection Ratio.

From curvature theory it can be shown that the midspan deflection should be 1.2 times the deflection of the node points which are at the third points of the ceiling-tie (Fig. 1). An analysis of the results shows that the average midspan/node deflection ratio for the 17½° and 22½° pitch trusses was exactly 1.2 but in the case of the 30° pitch the average ratio was 1.32. A possible explanation for this is that the queen ties in the 30° pitch truss provided more of a restraint to the node deflection, than in the lower pitch trusses.

2.3 Recovery.

The recovery of deflection immediately after the 24 hour test was worked out for the nodes and midspan of the ceiling-tie and were found to vary between 65% and 94%. The figures represent the recovery immediately after release of the loads. The deflection readings taken fifteen minutes after release of load indicate that the recovery had not reached its limit.

2.4 Load Factors at Failure.

The final load factors (i.e. ratio of final load to design load) were calculated separately for rafter, ceiling-tie and tank loads, as the magnitude and method of increasing the three different loads was such that they could not be increased at the same rate and simultaneously. In the case of the tank loads the trays supporting the dead weights had a limited capacity which when reached was kept constant. As the increments for the ceiling-tie load were small, these were put in one go at each increment stage. Only the rafter loading

could be increased steadily as this was applied by means of the hand winches.

The table below indicates as percentages the number of trusses with load factors 2.05, 2.15, 2.30 and 2.50 for ceiling-tie and rafters.

Pitch Deg	No. of Trusses	2.50	2.30	2.15	2.05
17½	16	56.3%	87.5%	93.8%	93.8%
22½	22	59.1%	81.8%	86.4%	86.4%
30	20	90.0%	95.0%	100%	100%
Total	58	69%	88%	93.1%	93.1%

Ceiling-Tie Load Factors

Pitch Deg	No. of Trusses	2.50	2.30	2.15	2.05
17½	16	68.8%	81.3%	87.5%	87.5%
22½	22	63.6%	81.8%	90.9%	90.9%
30	20	95%	100%	100%	100%
Total	58	75.9%	87.9%	93.1%	93.1%

Rafter Load Factors

From the tables above it appears that the 30° pitch trusses showed the best results. However, three points should be borne in mind when considering the other pitches and these are

- (i) Except for one truss there were no ceiling-tie failures and therefore the load factors obtained are not the ultimate load factors for the ceiling ties.
- (ii) In most cases where a rafter failure was recorded it was more of a lateral failure, due to the bracing being rendered inadequate at the higher loads, rather than the normal compression or bending failure in the direction of the load.
- (iii) A number of the strength tests were terminated when the lateral buckling or distortion became too dangerous.

2.5 Mode of Failure.

The types of failure encountered during the tests could broadly be classified under five headings as shown in the Table below. The lateral failure has been shown grouped with rafter break as in most cases where failure occurred in the rafter it was a combination of the two types.

Type of Failure	Phase I	Phase II	Overall
Rafter/lateral break	50.0%	66.7%	53.4%
Ceiling-tie break	2.2%	-	1.7%
Lateral distortion in rafters	45.6%	8.3%	37.9%
Q.T. withdrawal		25.0%	5.2%
Plate shear	2.2%		1.7%
No. of Trusses	46	12	58

Four of the failures did not occur in the timber but were plate failures; these occurred mainly in Phase II in the trusses where the thickness was 34 mm and the pitch $22\frac{1}{2}^{\circ}$. This would seem to indicate that the plate size was inadequate.

There was only one ceiling tie break although according to Table 3 in IS 193, 38% of the trusses should have failed in the ceiling tie and 14% could have failed in either the ceiling-tie or rafter. It has been the author's experience in the testing of trusses for outside clients that the ceiling-ties have always been adequate for whatever span used.

2.6 Derivation of Limiting Spans.

The derivation of limiting spans was based on a combination of test data and theoretical analysis. In doing so, the following assumptions were made

- (i) the truss members were uniform in cross-section and design properties and remained straight throughout the test.
- (ii) the truss members were in the same vertical plane and braced to prevent lateral buckling.
- (iii) the axial forces were determined on the basis of pinned joints with all loads acting as point loads at the joints.
- (iv) the bending moments were determined on the basis of half-fixity at apex and heel joints, continuity over all the internal node points, and allowance for sinking supports at nodes and apex.
- (v) the maximum combined stress occurred over the strut/rafter node in the case of the rafters and either the node or midspan in the case of the ceiling-tie.
- (vi) the joint slips increased linearly right up to failure.

The failure load was divided by the appropriate load factor given in Table 5 of IS 193 to obtain a safe working load for each truss. This load was then used together with the minimum dimensions of each member and a safe combined stress was determined for each truss at the three critical points stated in (v) above. The combined stress was then used to determine a span that would fail at a load factor of 2.5. The method was a combination of that adopted by Grainger (1976) and Davies (1976).

2.6.1 Theory.

As explained by Davies (1976) two systems are involved - the actual test and required result.

- (i) In the actual tested truss the combined stress at the critical points can be expressed as a function of the span (L_a), cross-sectional dimensions (d_a and b_a), pitch (θ) applied design loads on rafter ($W1_d$) and ceiling-tie ($W2_d$) and point load (P). In an ideal situation where failure occurs in the rafter and ceiling-tie simultaneously the load factor (F) can be defined as follows

$$F = \frac{W1_f}{W1_d} = \frac{W2_f}{W2_d}$$

where $W1_f$ and $W2_f$ are the failure loads on rafter and ceiling-tie respectively.

The combined stress (CSI) can be expressed as a function of all the variables stated above as follows

$$CSI = f (W1_d, W2_d, P, F, L_a, d_a, b_a, \theta)$$

- (ii) The combined stress index CS2) in the truss defined by the adjusted span (L), load factor 2.5 and cross-sectional dimensions d and b can be expressed as

$$CS2 = f(W1_d, W2_d, P, 2.5, L, d, b,)$$

By equating these two functions, the values of the adjusted span (L) can be determined since all the other variables are known.

When the effect of sinking supports and joint slip were included, the final equation was a fourth order equation in L. The method adopted for the solution of the equation was the Newton-Raphson iteration method with a convergence criterion of 0.001. The use of a computer program developed by the author, on the DEC VAX 750 simplified this task considerably.

2.6.2 Combined Stress Index.

In determining the combined stress values at the three critical locations, it was decided to include within the computer program the determination of the combined stress indices based on medium-term and short-term design stresses.

A frequency distribution of the medium term indices is shown in Figures 2, 3 and 4. From the figures it appears that the indices show a definite tendency to increase with increasing pitch in the case of the rafters. In the ceiling-tie the index was similar for the 30° and $22\frac{1}{2}^{\circ}$ pitches and then dropped for the $17\frac{1}{2}^{\circ}$ pitch. The average values are shown in the table below

	Pitch (Deg)		
	30	22½	17½
Rafter	1.818	1.569	1.381
C.Tie Node	1.364	1.306	1.101
C.Tie Midspan	1.404	1.305	0.916
Combined Stress Index			

The combined stress indices were all (except in one case) in excess of unity and would seem to confirm Davies' (1976) findings. Only the rafter indices showed an apparent relationship with pitch.

2.6.3 Relationships between Spans and Section Modulus.

The safe spans were calculated for the three critical locations (i.e. rafter node, ceiling-tie node and ceiling-tie midspan) and the results were grouped by pitch. In addition, the averages and 95% Lower Confidence Levels were worked out for each group of three trusses in Phase I and groups of two in Phase II. The results were further grouped by pitch and similar section modulus.

Two sets of graphs were plotted. In the first set the calculated safe span was plotted against section modulus for each pitch and the 95% Lower Confidence Level was plotted using normal statistical analyses. The second set of graphs drawn were plots of the individual 95% Lower Confidence Levels of each group of three against section modulus.

In all cases four regression models were tried as follows:

- (i) $Y = AX + B$
- (ii) $\log Y = AX + B$
- (iii) $\log Y = A \log X + B$
- (iv) $Y = AX$

Only the first two relationships are shown in Tables 2 and 3. The linear regression gave the best relationships in most cases.

2.6.4 Other Relationships.

Various other relationships were tried. These included

- (i) Safe working stress vs section modulus
- (ii) Safe span vs pitch for the various depths
- (iii) Safe working stress vs pitch for the various depths.

The correlations in the case of (i) were found to be too erratic to attach any confidence to them. The other relationships, although significant, were discarded as they each had 3 points only.

Pitch	O/A Span	Finished Sizes		No. Tested
		Rafter	Ceiling Tie	
17.5°	5.4	34 x 72	34 x 72	3
	7.6	34 x 97	34 x 97	3
	8.4	34 x 112	34 x 112	3
	9.0	34 x 120	34 x 120	3
22.5°	5.6	34 x 72	34 x 72	3
	8.1	34 x 97	34 x 97	3
	8.7	34 x 112	34 x 112	3
	9.3	34 x 120	34 x 120	3
	8.7	34 x 112	34 x 97	3
	8.7	34 x 97	34 x 112	3
30°	6.0	34 x 72	34 x 72	3
	8.3	34 x 97	34 x 97	1
	9.1	34 x 112	34 x 112	3
	9.8	34 x 120	34 x 120	3
	8.3	34 x 112	34 x 97	3
	8.3	34 x 97	34 x 112	3

PHASE I

17.5°	5.9	34 x 97	34 x 97	2
	7.6	41 x 97	41 x 97	2
22.5°	8.3	34 x 120	34 x 120	2
	8.1	41 x 97	41 x 97	2
30°	8.4	34 x 112	34 x 112	2
	8.3	41 x 97	41 x 97	2

PHASE II

Table 1 : DETAILS OF TRUSSES

Pitch	Y = AX + B		Corr Coeff r	log Y = AX + B		Corr Coeff
	A	B		A	B	
17½	0.0627	5175	0.994	5676	0.32 x 10 ⁻⁵	0.992
22½	0.0782	4903	0.972	5548	0.39 x 10 ⁻⁵	0.966
30	0.0871	4920	0.975	5740	0.40 x 10 ⁻⁵	0.978
RAFTERS						
17½	0.0562	5410	0.999	5834	0.29 x 10 ⁻⁵	0.997
22½	0.0667	5205	0.879	5579	0.35 x 10 ⁻⁵	0.876
30	0.0846	4630	0.976	5369	0.42 x 10 ⁻⁵	0.967
CEILING-TIE NODE						
17½	0.0336	6223	0.958	6416	0.18 x 10 ⁻⁵	0.963
22½	0.0516	5182	0.973	5521	0.29 x 10 ⁻⁵	0.966
30	0.0739	4107	0.984	4774	0.41 x 10 ⁻⁵	0.976
CEILING-TIE MIDSPAN						

Table 2 : REGRESSION ANALYSIS.
Calculated Safe Span (Y) vs Section Modulus (X).

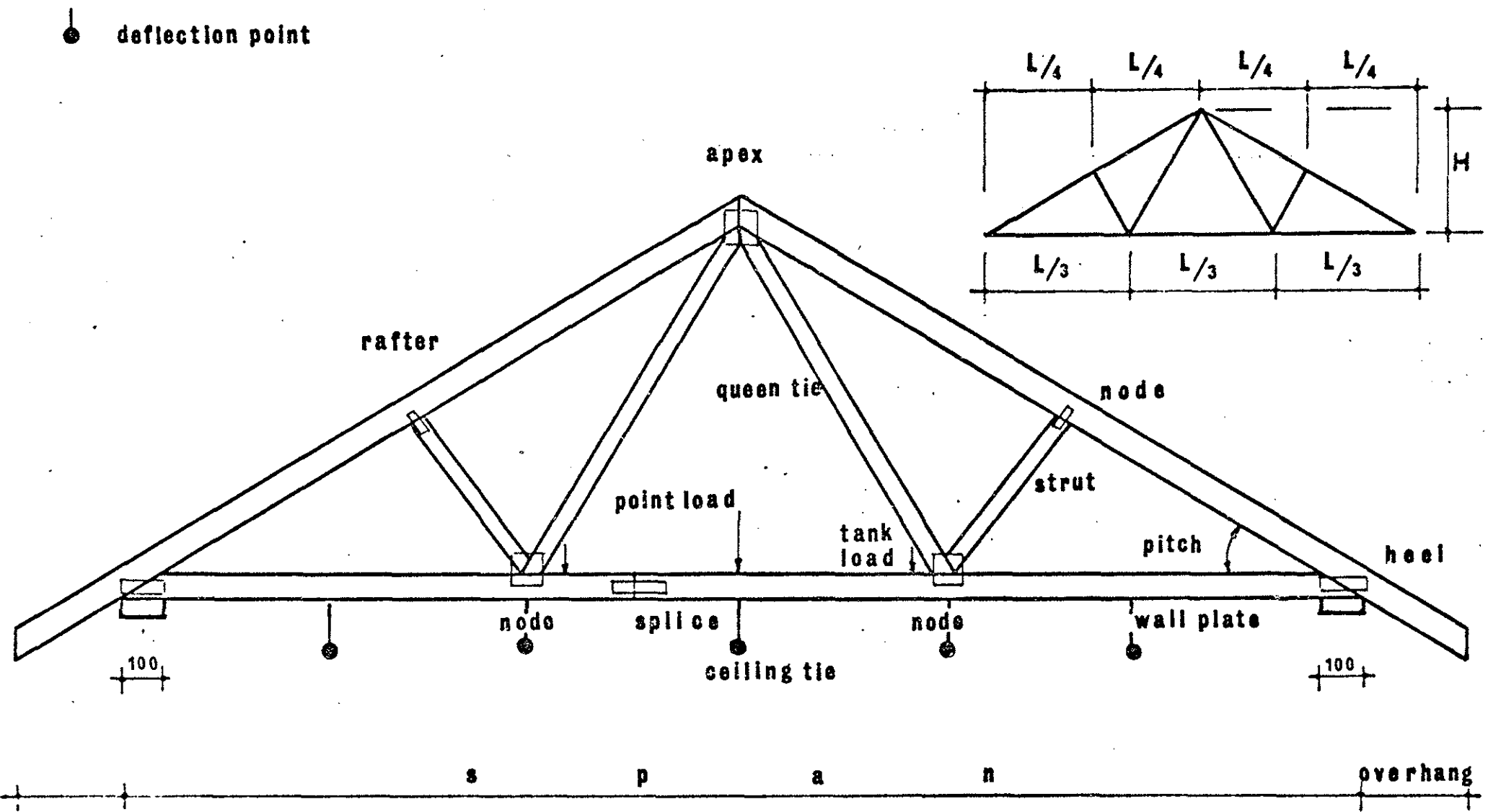
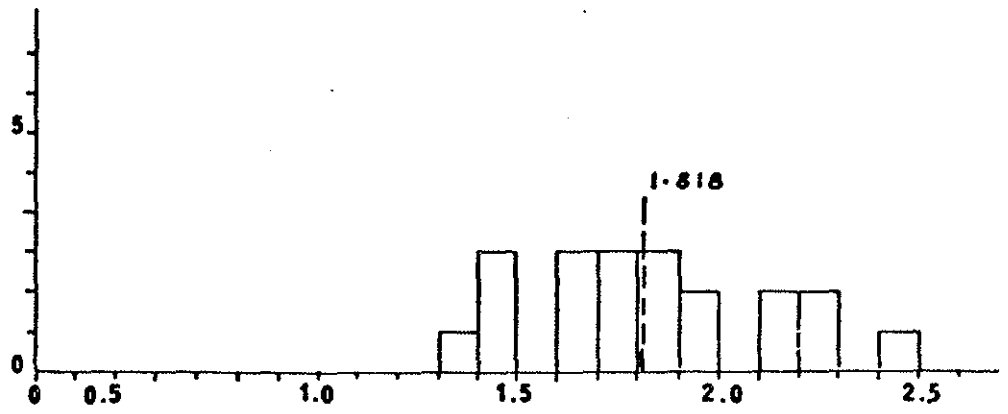

Fig: 1.1 Details of Fink Trussed Rafter

RAFTER

30°



22.5°

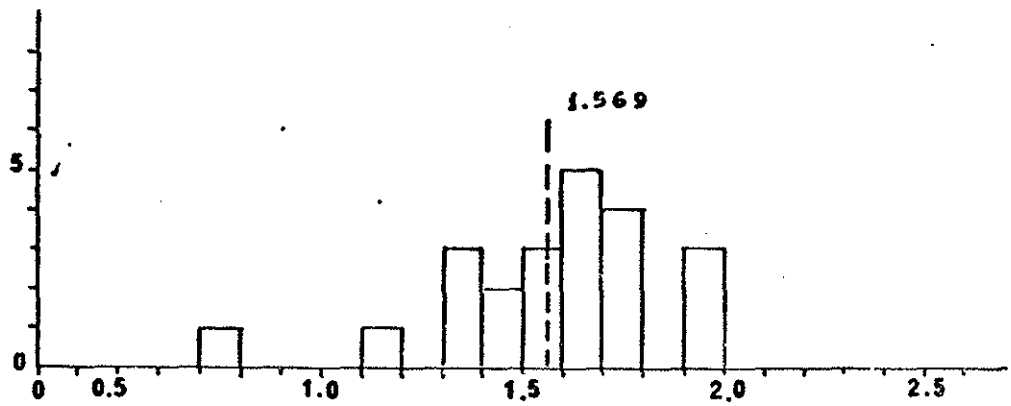

17.5°

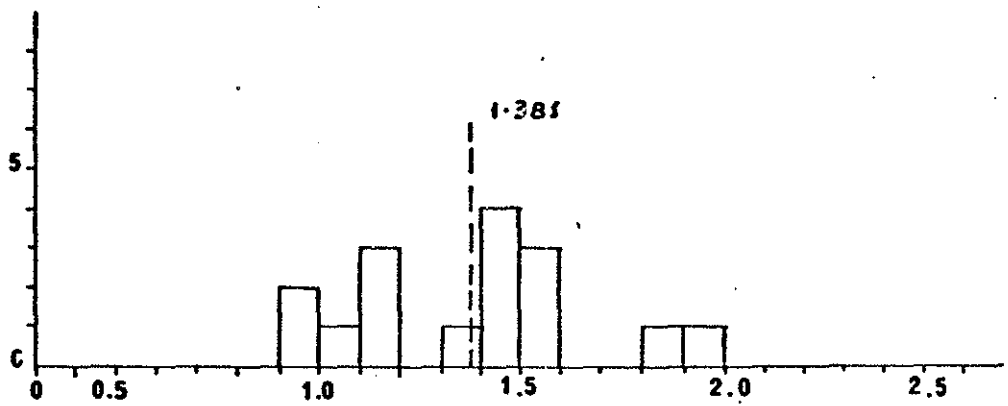

total

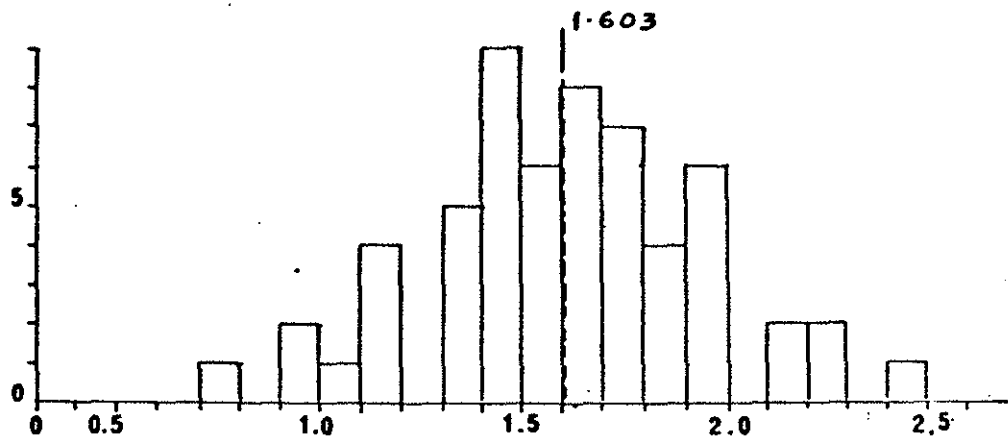
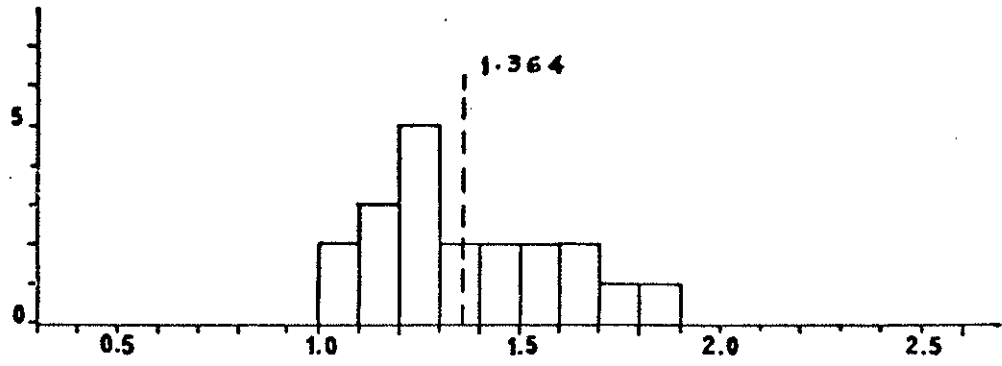

Fig 2. Distribution of Combined Stress Index for Rafter

C.T. NODE

30°



22.5°

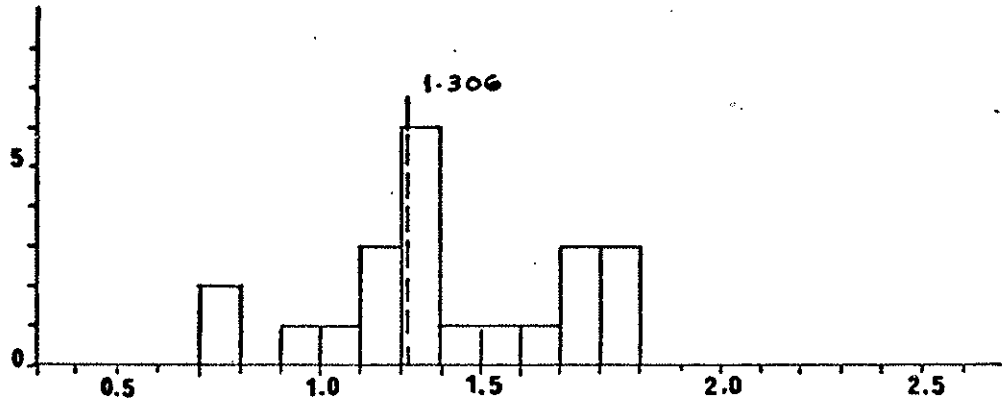

17.5°

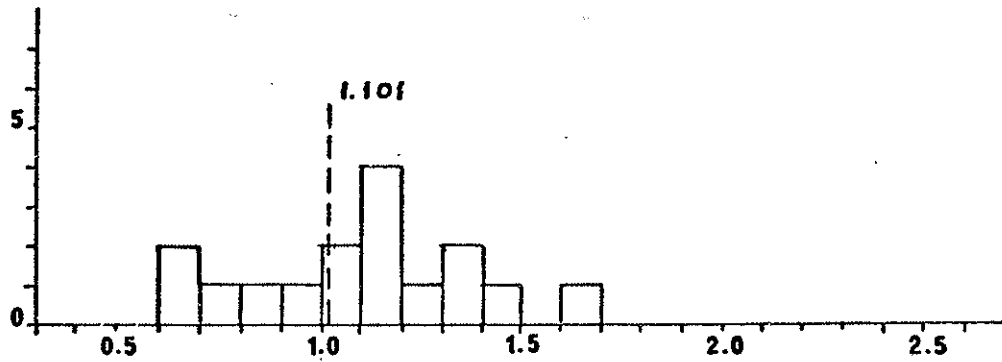

total

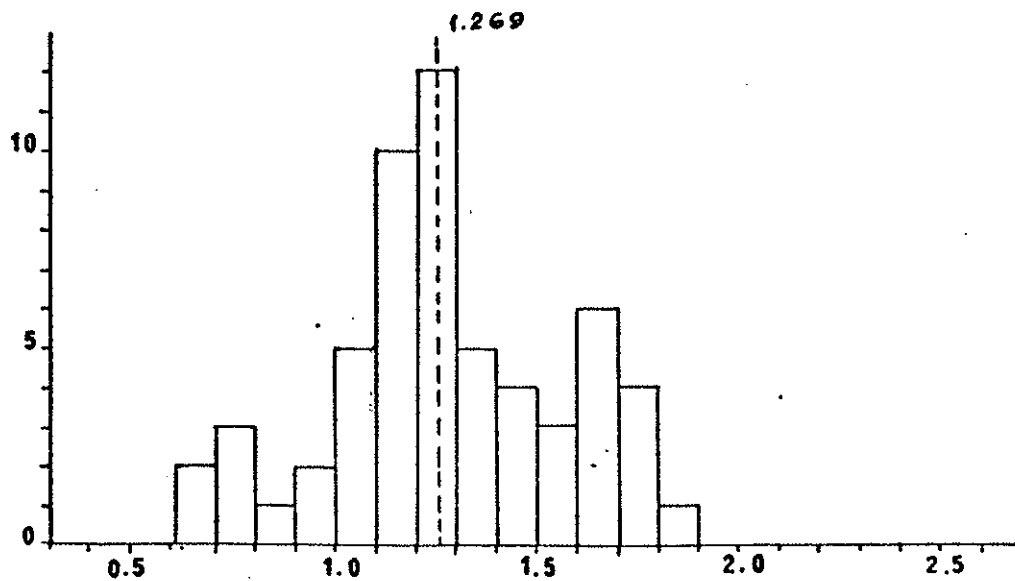
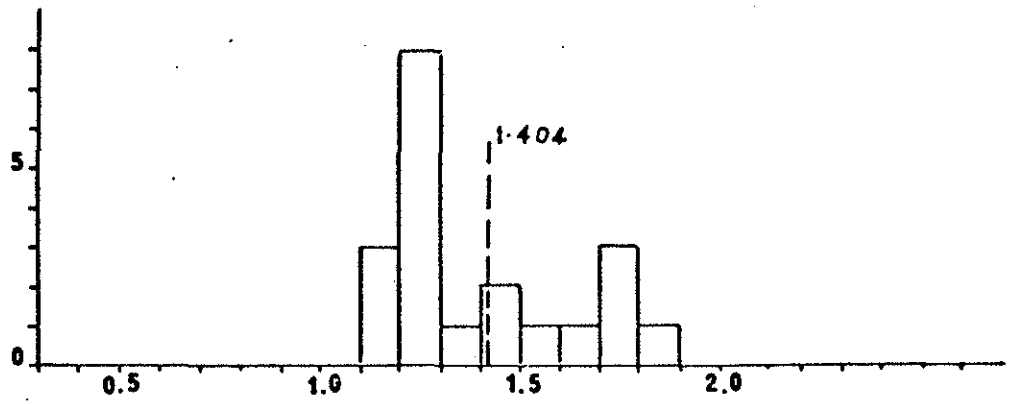

Fig 3 Distribution of Combined Stress Index for C.T. NODE

C.T. MIDSPAN

30°



22.5°

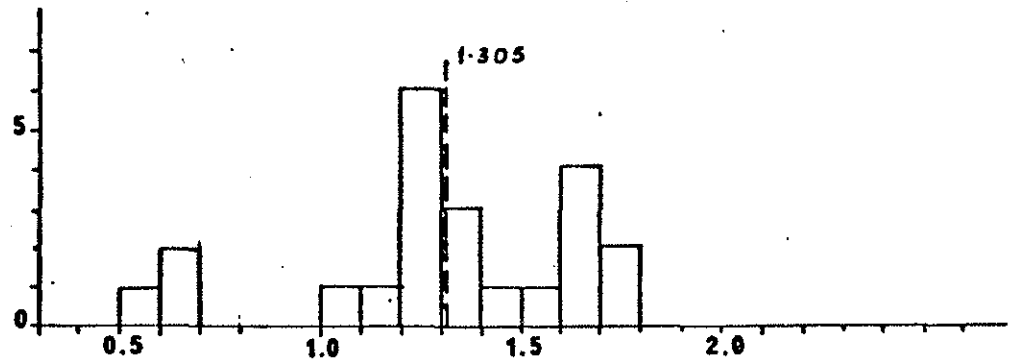

17.5°

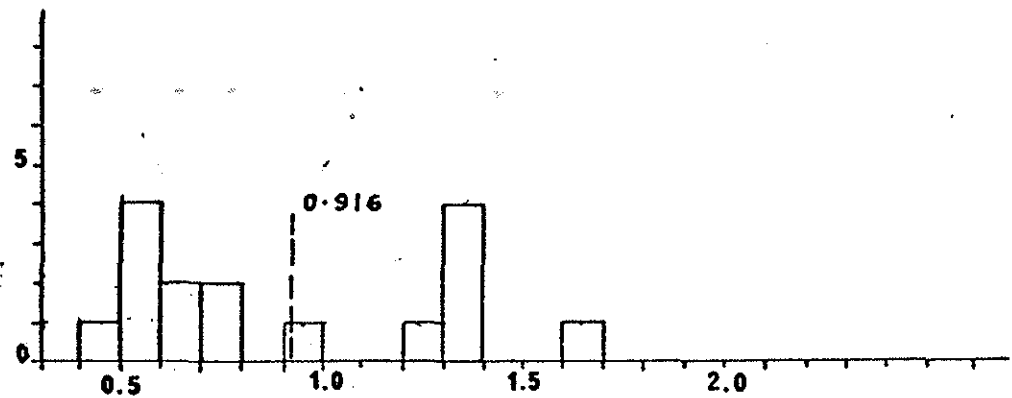

total

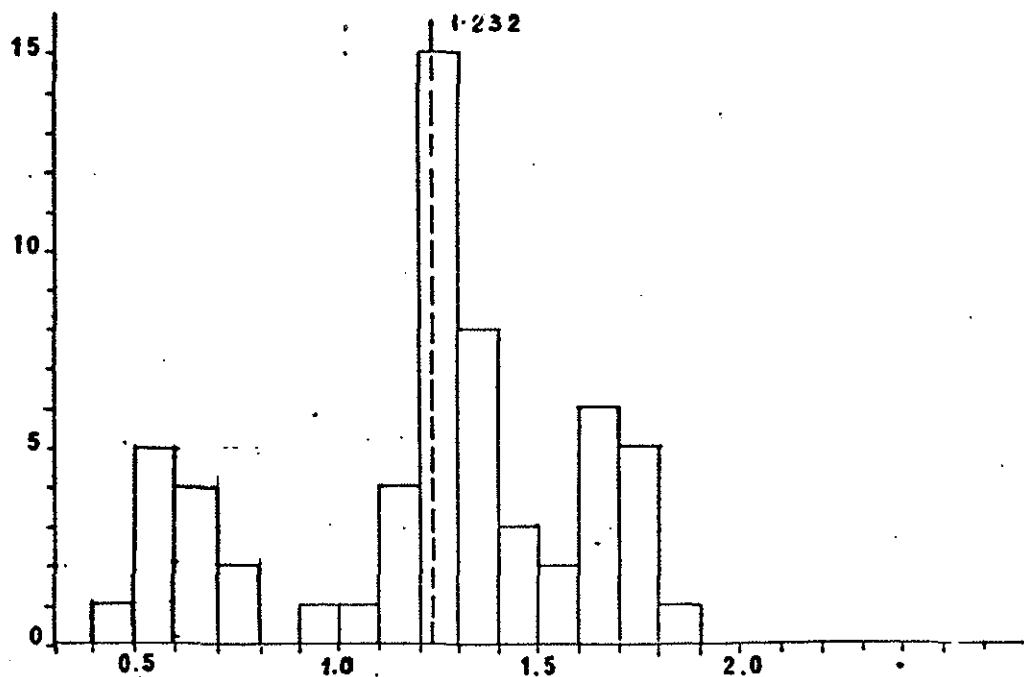

Fig 4 Distribution of Combined Stress Index for C.T. Midspan

INTERNATIONAL COUNCIL FOR BUILDING RESEARCH STUDIES AND DOCUMENTATION
WORKING COMMISSION W18 - TIMBER STRUCTURES

DETERMINATION OF BRACING STRUCTURES
FOR COMPRESSION MEMBERS AND BEAMS

by

H Brüninghoff
Federal Republic of Germany

LILLEHAMMER
NORWAY
MAY/JUNE 1983

INTERNATIONAL COUNCIL FOR BUILDING RESEARCH STUDIES AND DOCUMENTATION
WORKING COMMISSION W18 - TIMBER STRUCTURES

DETERMINATION OF BRACING STRUCTURES
FOR COMPRESSION MEMBERS AND BEAMS

by

H Brüninghoff
Federal Republic of Germany

LILLEHAMMER
NORWAY
MAY/JUNE 1983

INTERNATIONAL COUNCIL FOR BUILDING RESEARCH STUDIES AND DOCUMENTATION
WORKING COMMISSION W18 - TIMBER STRUCTURES

DETERMINATION OF BRACING STRUCTURES
FOR COMPRESSION MEMBERS AND BEAMS

by

H Brüninghoff
Federal Republic of Germany

LILLEHAMMER
NORWAY
MAY/JUNE 1983

DETERMINATION OF BRACING STRUCTURES FOR COMPRESSION MEMBERS AND BEAMS

1. INTRODUCTION

To obtain a sufficient lateral stability of wooden structural members they get connected to walls, supports or bracing members being enough resistant. Those prevent too great lateral deflections rectangular to the main supporting direction of the components. Simultaneously they also can be taken to carry exterior loads such as wind.

Additional to the exterior loads there are no further forces to the bracing members as long as all parts are ideal straight and in a vertical position and if there is a perfect bringing in of loads, consequently the applied surcharge has no components rectangular to the main supporting direction of the wooden parts. In practise deviations of the ideal position have to be accepted due to unavoidable manufacturing and assembling inaccuracies. They always occur as soon as lateral thrusts due to the wind or other from the outside attacking horizontal forces are led in the plane of the supports and bracings, and thus cause deformations.

2. PRE-CONDITIONS AND FUNDAMENTALS

We look at a beam with a rectangular cross section, being constant along the support. The part is loaded vertically and supported elastically in a horizontal line. Further data can be taken from fig. 1.

Assuming the validity of Hooke's law and in addition of Bernoulli's theorem, so that one gets the Bernoulli-Euler's theorem of the technical bending theory, $1/r = M/(EI)$. All the deformations have to be small in comparison to the main dimensions of the building parts. A pure torsion according to de Saint Venant is presupposed. (Rectangular cross cuts have no further considerable torsional rigidity as it have for example sections with webs and flanges.)

At a very small segment of beam, as shown in fig. 2, there can be written down six conditions of balance, combined to two equations, (2) and (3). To simplify the differential quotients e.g. $dM/dx = M'$ is applied.

$$M_z'' - (M_y \cdot \varphi)'' - q = 0 \quad (1)$$

$$M_D' - M_y \cdot v'' + p \cdot e \cdot \varphi - q \cdot s = 0 \quad (2)$$

The following expressions can be taken

$$M_z = -EI_z \cdot (v - v_0)'' \quad (3)$$

$$M_D = GI_D (\varphi - \varphi_0)' \quad (4)$$

$$m \cdot q + w = EI_W \left[(v - v_0)'''' + s (\varphi - \varphi_0)'''' \right] \quad (5)$$

in which v_0 and φ_0 are the displacements of the beam without loads. If the eq. (4) to (6) are inserted in (2) and (3) one gets two connected inhomogeneous differential equations. The following expressions have been assumed for the initial displacements

$$v_0 = \bar{v} \cdot \sin (\pi/L) \cdot x \quad (6)$$

$$\varphi_0 = \bar{\varphi} \cdot \sin (\pi/L) \cdot x \quad (7)$$

The system of differential equations can be exactly calculated, if the coefficients are constant, these are in that case the values of the cross section and the bending moment M_y . A constant moment however means, that the connected loads are equal to zero. The direct loading and above all the point of the attacking forces in the cross section are without doubt important to the problem of stability.

The beam is simply supported at the ends, $u = v = 0$, and secured against rotation about the z-axis, $\varphi = 0$. A constant loading produces a bending moment in form of a parabolic curve. Approximately a sine wave is substituted for the parabolic line.

$$M = \bar{M} \cdot \sin (\pi / L) \cdot x \quad (8)$$

The functions (9) and (10) satisfy the boundary conditions but not the differential equations.

$$v = (V + \bar{v}) \cdot \sin (\pi / L) \cdot x \quad (9)$$

$$\varphi = (\Phi + \bar{\varphi}) \cdot \sin (\pi / L) \cdot x \quad (10)$$

The unknown values V and Φ are determined by the aid of an approximation method.

As we have now the deformations, the loadings of the bracing members can be found out of eq. (5). Eq. (11) gives the loads on the bracing structure caused by exterior (e.g. wind) or interior lateral forces. Only the initial curvature $u_0 = \bar{u} \cdot \sin(\pi / L) \cdot x$ is taken, the initial twist neglected. The bending rigidity EI_z of the beam is normally low in comparison with that of the bracing structure and is therefore taken equal to zero.

$$mq + w = \frac{(q_V^- + q_W^-)}{Ne} \sin (\pi/L) \cdot x \quad , \quad (11.1)$$

in which

$$q_V^- = \bar{v} \frac{\pi^2}{L^2} m \frac{N \cdot \left(\frac{1}{s} \cdot GI_D - \frac{e}{s} \cdot M \right) + \frac{1}{s} \cdot M^2}{\frac{\pi^2}{L^2} \cdot \frac{s}{m} \cdot EI_W} \quad , \quad (11.2)$$

$$q_W^- = \bar{w} \cdot \frac{(2 - \frac{e}{s}) \cdot M + \frac{1}{s} GI_D - sN}{\frac{\pi^2}{L^2} \cdot \frac{s}{m} \cdot EI_W} \quad , \quad (11.3)$$

$$Ne = \left[1 - \frac{sN}{\frac{\pi^2}{L^2} \cdot \frac{s}{m} \cdot EI_W} \right] \left[1 + \frac{\frac{1}{s} \cdot GI_D - \frac{e}{s} \cdot M}{\frac{\pi^2}{L^2} \cdot \frac{s}{m} \cdot EI_W} \right] - \left[1 - \frac{M}{\frac{\pi^2}{L^2} \cdot \frac{s}{m} \cdot EI_W} \right]^2 \quad (11.4)$$

In conformity to the solution of the differential equations

$$M = \frac{8}{3\pi} \bar{M} = \text{ca. } 0,85 \bar{M}$$

can be introduced. \bar{M} is the maximum bending moment of the sine-shaped function. \bar{w} is the maximum lateral force of an odd Fourier's series of which only the first term is taken.

3. COMPRESSION MEMBERS

Setting $M = e = 0$ in eq. (11) and assuming that the lateral support of the beam is in the middle of the cross section, so that also $s = 0$, the lateral forces can be expressed as

$$mq + w = \frac{\bar{v} \cdot (\pi^2/L^2) \cdot mN + \bar{w}}{1 - \frac{mN}{(\pi^2/L^2) \cdot EI_W}} \cdot \sin(\pi/L) \cdot x \quad (12)$$

The effort for the calculation of the bracing stiffness, which is contained in eq. (12), is normally considerable, because the bending and shear rigidity of the bracing structure and also the slip of the used connectors have to be considered. To simplify the formula a bracing member is chosen with such a stiffness, that an assumed deformation is not exceeded.

The maximum deflection of the bracing structure is

$$f = \frac{m\bar{q} + \bar{w}}{EI_W} \cdot \frac{L^4}{\pi^4} \quad (13)$$

in which

$$\begin{aligned} w &= \bar{w} \cdot \sin(\pi/L) \cdot x \\ q &= \bar{q} \cdot \sin(\pi/L) \cdot x \end{aligned}$$

If the eq. (13) is inserted in (12), one gets

$$mq = (\pi^2/L^2) \cdot mN \cdot (\bar{v} + f) \cdot \sin(\pi/L) \cdot x \quad (14)$$

$$\text{and with} \quad \bar{v} = L/\beta_v \quad (15),$$

$$f = L/\beta_f \quad (16),$$

$$mq = q_s = \frac{mN}{L \cdot k_N} \cdot \sin(\pi/L) \times \quad , \quad (17)$$

in which

$$k_N = \frac{1}{\pi^2 \cdot \left(\frac{1}{\beta_v} + \frac{1}{\beta_f} \right)} \quad . \quad (18)$$

k_N is given in Table 1 for different values of the assumed initial deflections and the tolerated deformations of the bracing structure.

The function of the lateral forces is sine-shaped. The accompanying shearing forces are following the cosine wave, the bending moments again the sine wave. Having as usual an uniform load, it would be practicable, to transform the sine-shaped load into an uniform load. As shown on fig. 3, it can be requested, that for example the maximum bending moment or the maximum shear force are corresponding.

Here the bending moment was chosen. The sine-shaped and the parabolic moments are similar. In that case also the reduction of the shear force is less, so that a sufficient shear reinforcement is given. The values k_N , multiplied by $8/\pi^2$ are shown in table 1 in parentheses.

Fig. 4 also gives the coefficient k_N in dependance of the initial deflections of the compression member and of the guaranteed deformation of the bracing structure.

4. FLEXURAL MEMBERS (BEAMS)

If in the generally valid equations (11) the axial force N is equal to zero, the eq. (19) and (20) will be received.

$$mq + w = \frac{\bar{v} \frac{\pi^2}{L^2} \cdot m \frac{M}{S} k_m + \bar{w}}{1 - \frac{m \cdot M}{\frac{\pi^2}{L^2} \cdot EI_W} \cdot k_m} \cdot \sin(\pi/L) \cdot x \quad , \quad (19)$$

$$k_m = \frac{1}{(2 - \frac{e}{S}) + \frac{GI}{MS} D} \quad (20)$$

Eq. (19) for the beams conforms to eq. (12) for the compression members. The nondimensional value k_s takes into account the torsional rigidity of the regarded flexural member. M can be replaced by the reduced value $8/(3 \cdot \pi) \cdot \bar{M} \approx 0,85 \cdot \bar{M}$, in which \bar{M} is the maximum of the sine-shaped bending moment.

After the calculation of k_m the handling of eq. (19), beams, is as easy as that of eq. (12), compression members. It should be said, that the direction of the bending moment and height of the exterior forces can be chosen at anyone's discretion. e and s are positively valued, if they are from the main axis upward directed. It is possible, to choose these parameters freely and to calculate beams, of which the upper chords are loaded and the lower flanges are supported.

The boundary of stability of the whole stiffed system has to be considered. That is given, if the denominator of the eq. (19) becomes zero, so that the lateral stability forces are growing without limit.

A sufficient stability is guaranteed, if

$$\frac{m \cdot (M/s) \cdot k_m}{(\pi^2/L^2) \cdot EI_W} \leq 1 \quad (21)$$

The check of the stability is especially necessary for beams, supported at the tension flange and for bracings of such a rigidity, which is not sufficient without any doubt. This has to be regarded, if bracings are formed by beams of less heights or by columns, which are not fixed at the upper end.

To simplify eq. (13) can be used as a relation between the bracing rigidity EI_W and a bracing deformation, which can be guaranteed. The type of the equation for compression members and beams is very similar; in comparison with the eq. (13) to (18) can be written

$$mq = q_s = \frac{m \cdot M}{L \cdot s \cdot k_s} \cdot \sin(\pi/L) \times \quad , \quad (22)$$

wherein is

$$k_s = \frac{(2 - \frac{e}{s}) + \frac{GI}{Ms} D}{\pi^2 \cdot (\frac{1}{\beta_v} + \frac{1}{\beta_f})} \quad (23)$$

Now the stability limit of the stiffed system is not clear in any case, because the coefficient of deformation β_f , and herewith the deflection, is chosen especially. Therefore for the development only beams are regarded, which are supported at the compression flange. These types are normally stable, if the bracing struc-

ture is formed regularly. The maximum lateral loads are received, if the exterior uniform loads are set on the upper flange, which is the compression part of the beams under positive bending moments. Only regarded the parts, of which are supported and loaded the upper compression flanges, than is $s = e = h/2$. The eq. (22) and (23) can be expressed as

$$q_s = \frac{m \cdot M}{L \cdot h \cdot k_h} \sin(\pi/L) x \quad (24)$$

with

$$k_h = \frac{1 + \frac{2 \cdot G I_D}{M \cdot h}}{2 \cdot \pi^2 \cdot \left(\frac{1}{\beta_v} + \frac{1}{\beta_f} \right)} \quad (25)$$

Introducing

$$I_D = \eta \cdot b^3 \cdot h \quad , \quad \eta \cong (1 - 0,63 (b/h))/3 \quad ,$$

$$M = \tilde{G}_m \cdot W \quad , \quad W = b h^2 / 6$$

and assuming an initial deflection and a known deformation of the bracing structure, k_h of eq. (25) depends only on the dimensionless relations h/b and G/\tilde{G}_m . With

$$M = \frac{8}{3 \cdot \pi} \bar{M} \quad \text{is}$$

$$q_s = \frac{m \bar{M}}{L \cdot h \cdot \bar{k}_h} \cdot \sin(\pi/L) x \quad (26)$$

wherein

$$\bar{k}_h = \frac{3 \left(1 + \frac{4(1-0,63(b/h))}{8/(3 \cdot \pi)} \cdot \frac{G}{\tilde{G}_m} \cdot \frac{b^2}{h^2} \right)}{16 \cdot \pi \cdot \left(\frac{1}{\beta_v} + \frac{1}{\beta_f} \right)} \quad (27)$$

The profile coefficient s or h , connected with the bending moment, is only chosen, that k_s , k_h and \bar{k}_h are dimensionless. In the same manner the width of the rectangular cross section can be introduced

$$q_s = \frac{m \cdot M}{L \cdot b \cdot \bar{k}_b} \cdot \sin(\pi/L) x \quad , \quad (28)$$

in which

$$\bar{k}_b = (h/b) \cdot \bar{k}_h \quad . \quad (29)$$

Fig. (5) shows \bar{k}_h and \bar{k}_b in relationship of h/b . As parameter $\beta_v = 500$ and $\beta_f = 1000$ are chosen.

Beams of a practical importance have a cross section relation h/b between 4 and 15. The coefficient \bar{k}_h moves here very much. The coefficient \bar{k}_b has a less variation in the same area with a special minimum in the neighbourhood of $h/b = 13$. Therefore the eq. (28) is the most practicable approximation.

Fig. 6 shows the value \bar{k}_b in relationship of h/b and G/G_m . The initial deflection \bar{v} and the deformation of the bracing structure can be chosen freely.

The coefficient of the sine-shaped lateral force can be transformed into a value for uniform loads in the same manner as shown in chapter 3.

5. RÉSUMÉ

Equations are given, which allow to calculate the loadings of bracing structures. The members with the risk of lateral deflection can be forced by compression forces and by bending moments. The favourable torsional rigidity of the beams is taken into consideration.

The lateral loads of compression members, e.g. flanges of trusses, and of glued laminated beams, subjekt to bending and of combined stressed parts can be calculated.

Simplified expressions are given for parts, subjekt to pure compression or bending. If the rigidity of the bracing structure is assumed, so that a given maximum of the deflection is not exceeded, very simple expressions are available.

Schrifttum

- [1] DIN 1052: Holzbauwerke. Berechnung und Ausführung. Ausgabe Oktober 1969.
- [2] Möhler, K. und W. Schelling: Zur Bemessung von Knickverbänden und Knickaussteifungen im Holzbau. Bauingenieur 43 (1968) S. 43/48.
- [3] Gerold, W.: Zur Frage der Beanspruchung von stabilisierenden Verbänden und Trägern. Stahlbau 32 (1963) S. 278/281.
- [4] Brüninghoff, H.: Spannungen und Stabilität bei quergestützten Brettschichtträgern. Dissertation Universität Karlsruhe (TH) 1972.
- [5] Möhler, K. und W. Herröder: Seitenlast zur Bemessung der Aussteifungskonstruktionen parallelgurtiger Brettschichtträger. Holzbau-Statik-Aktuell, Folge 2, 11/1977
- [6] Möhler, K., J. Ehlbeck, G. Hempel und P. Köster: Erläuterungen zu DIN 1052, Blatt 1 und 2 – Holzbauwerke – Ausgabe Oktober 1969. Hrsg. Arbeitsgem. Holz e. V. in Zusammenarbeit mit dem Bund Dt. Zimmermeister. Bruderverlag Karlsruhe 1971

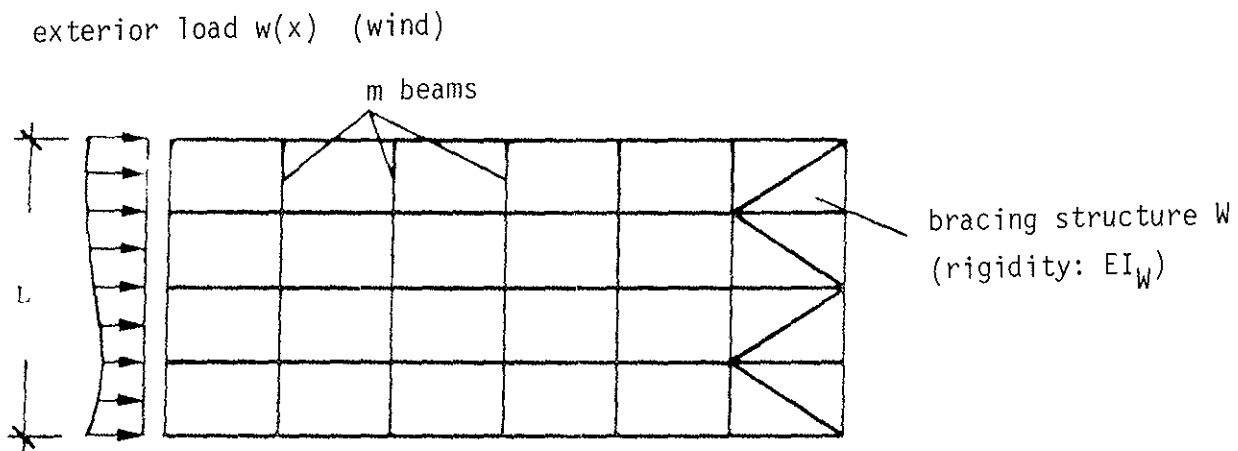

a) Ground plan

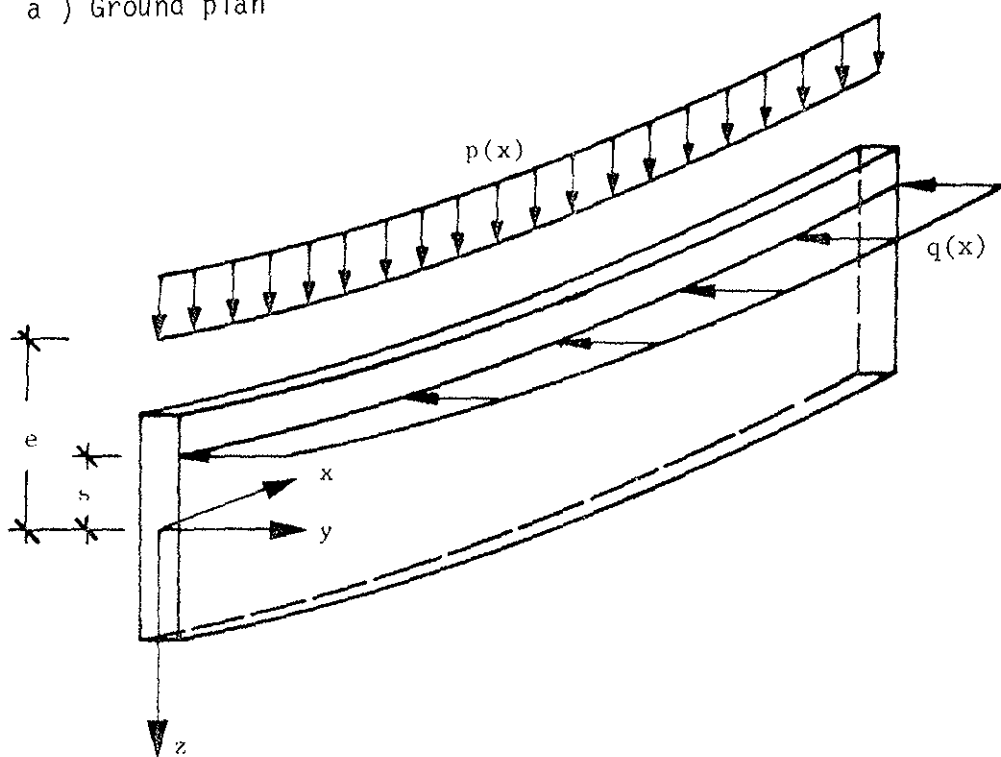

b) Beam, vertically loaded
laterally supported

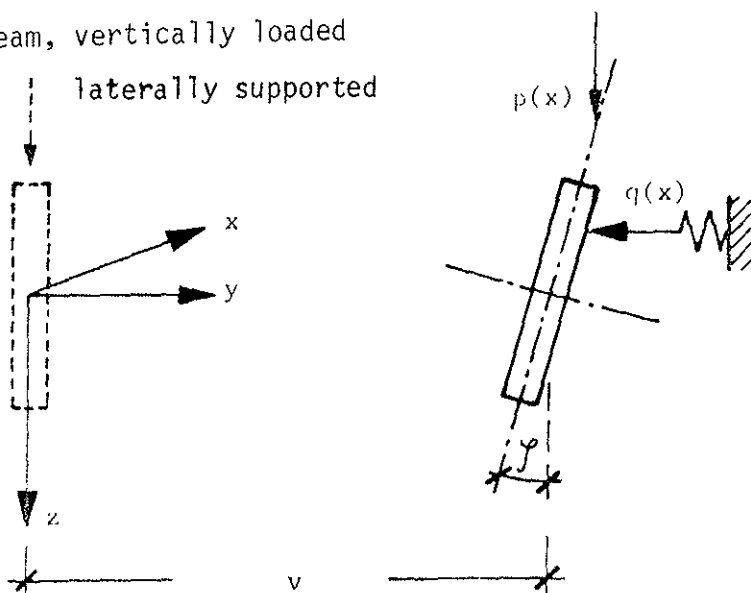

c) Deflected cross section

Fig. 1 Laterally supported system

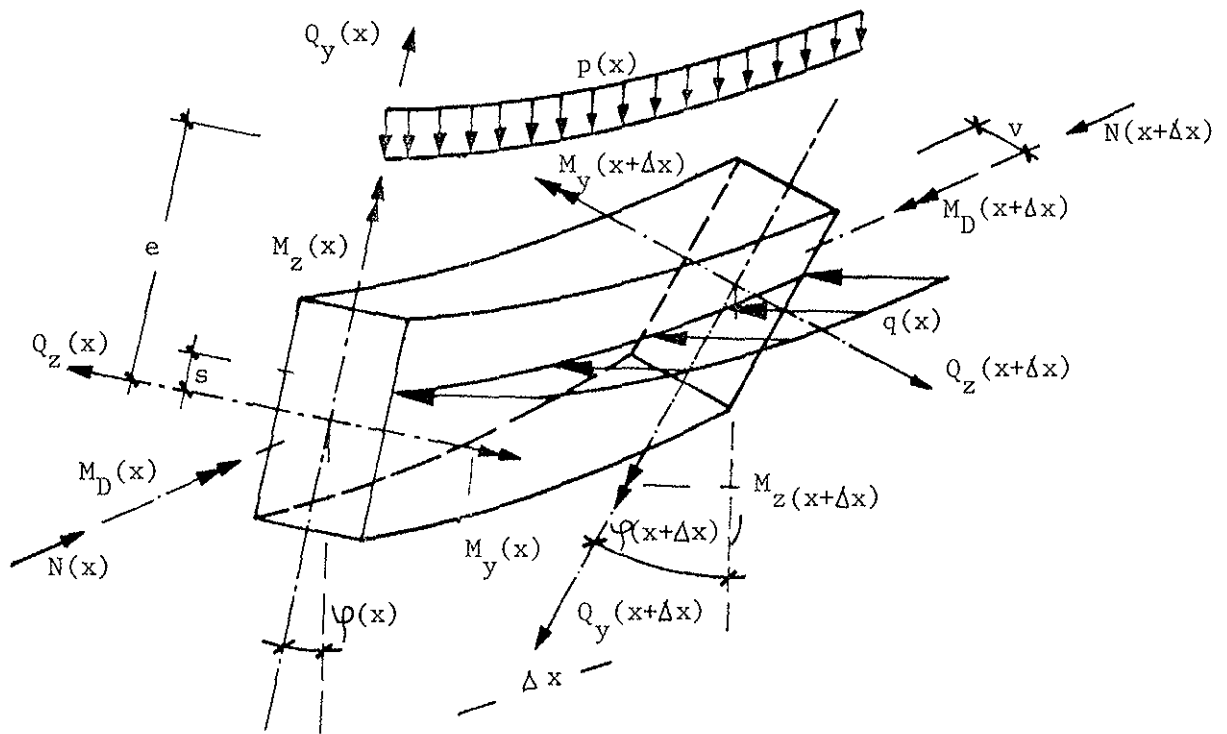

Fig. 2 Sectional forces of a beam element, vertically loaded and laterally supported.

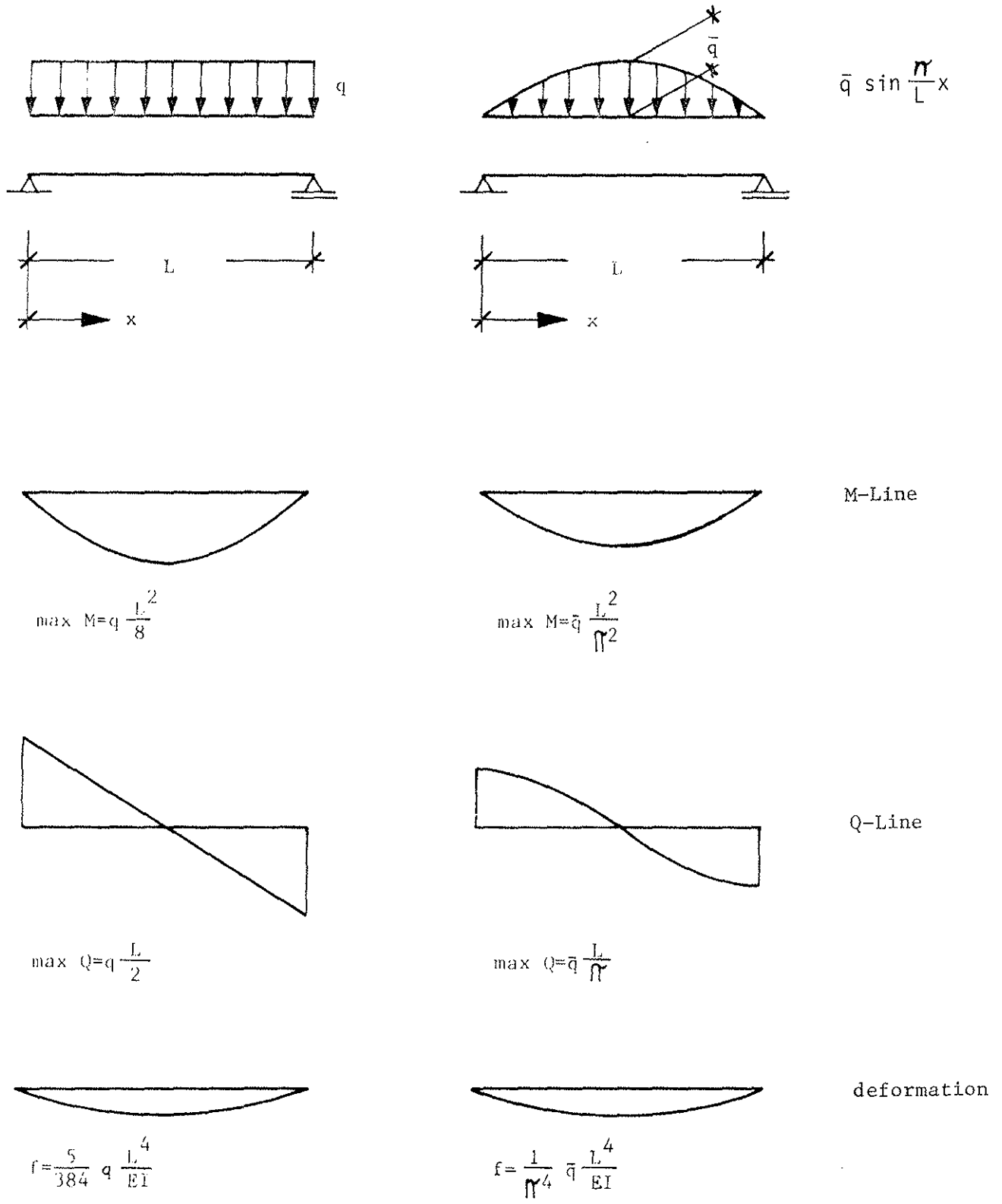

Fig. 3 Forces acting on a beam with uniform or sine-shaped loads

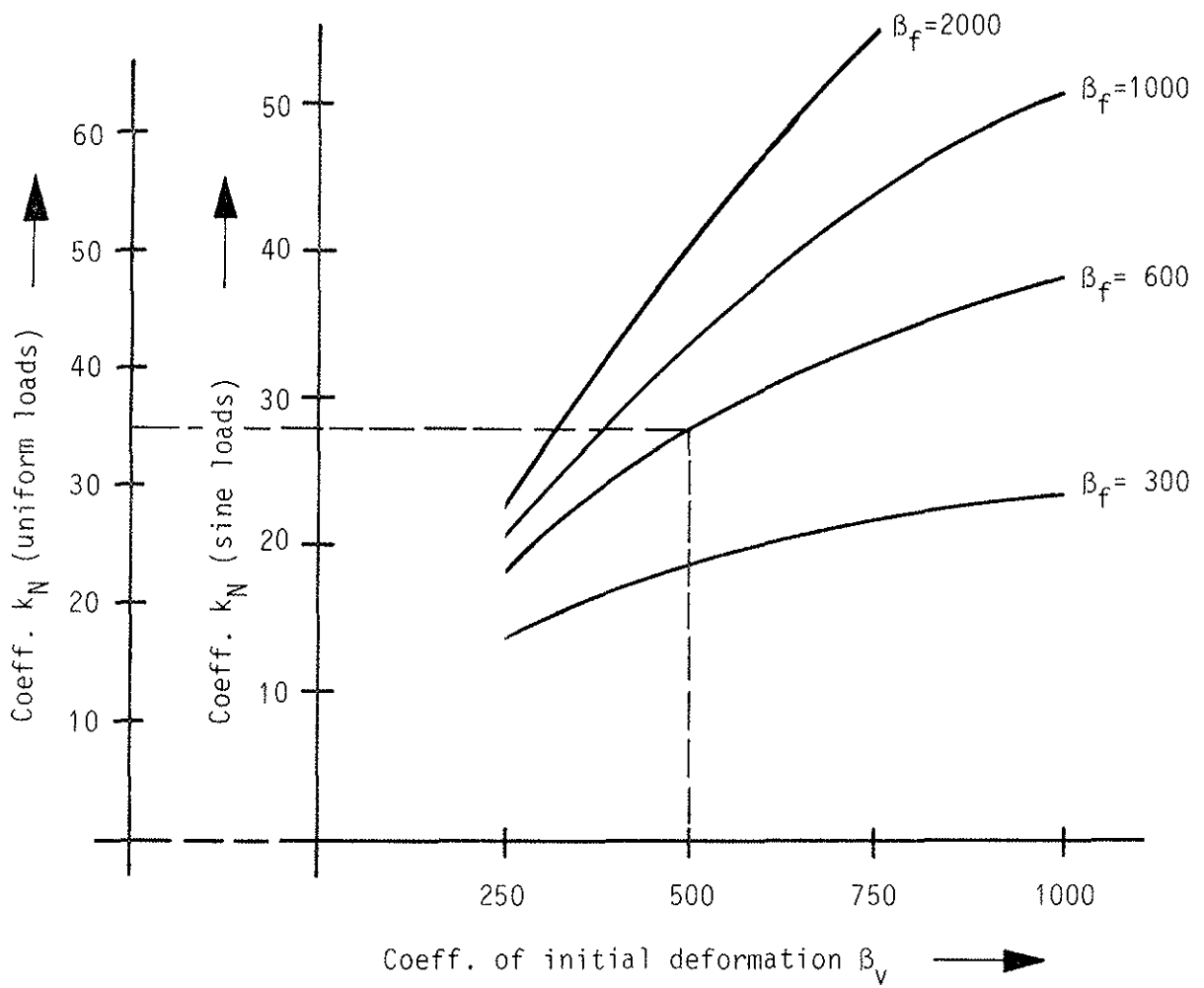

Fig. 4 Coefficient k_N of the bracing load in dependence of the initial deflection of the compression members and the guaranteed deformation of the bracing structure.

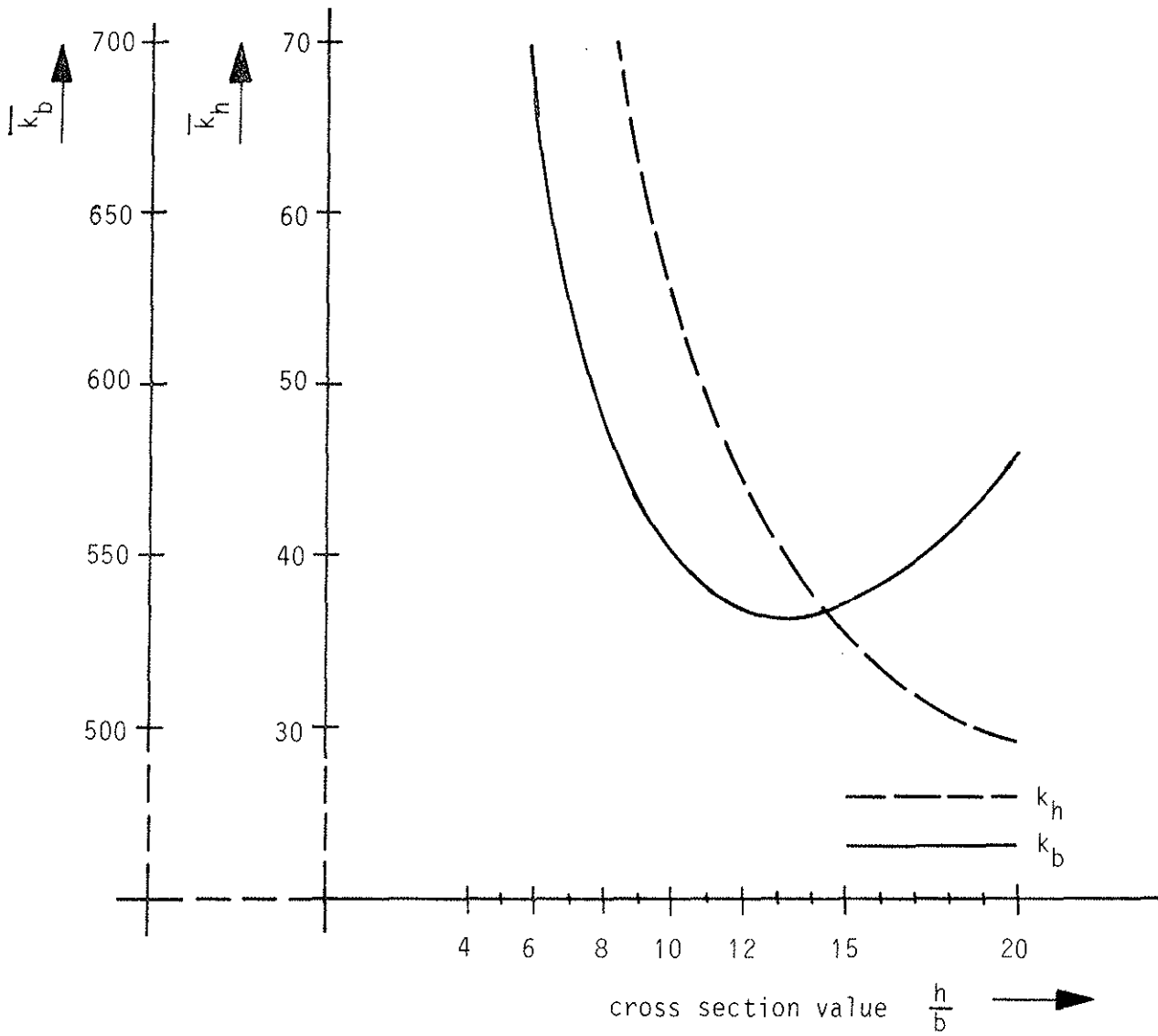

Fig. 5 Coeff. \bar{k}_h and \bar{k}_b in relationship of the cross section quotient h/b ($\beta_V=500$, $\beta_F=1000$, $G/ =40$)

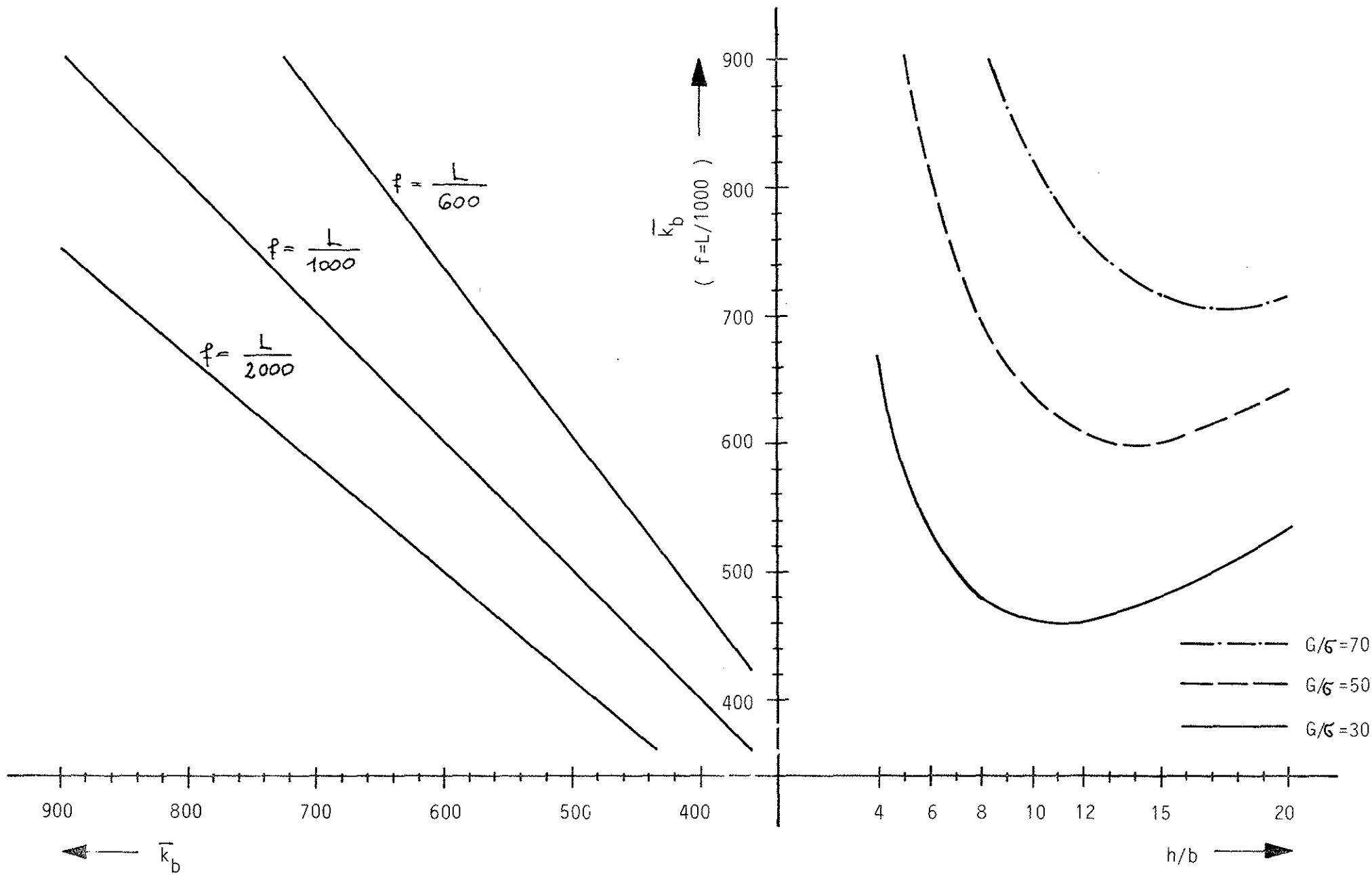

Fig. 6 Coeff. \bar{k}_b as a function of the ratios h/b , G/σ and the bracing deformation f (initial deflection $\bar{v}=L/500$)

$\beta_v \backslash \beta_f$	300	600	1000	2000
250	14 (17)	18 (22)	20 (25)	22 (28)
500	19 (23)	28 (34)	34 (42)	41 (50)
1000	23 (29)	38 (47)	51 (62)	68 (83)

Table 1: Coefficient k_N for the sine-shaped lateral force of compression members in dependence of the pre-deflection of the beams and of the guaranteed deformation of the bracing structure.

(In parentheses: k_N for uniform loads)

INTERNATIONAL COUNCIL FOR BUILDING RESEARCH STUDIES AND DOCUMENTATION
WORKING COMMISSION W18 - TIMBER STRUCTURES

NOTES ON SAMPLING AND STRENGTH PREDICTION
OF STRESS GRADED STRUCTURAL TIMBER

by

P. Glos

Lehrstuhl Baukonstruktion und Holzbau
Technische Universität München
Federal Republic of Germany

LILLEHAMMER
NORWAY
MAY/JUNE 1983

INTERNATIONAL COUNCIL FOR BUILDING RESEARCH STUDIES AND DOCUMENTATION

WORKING COMMISSION W18 - TIMBER STRUCTURES

NOTES ON SAMPLING AND STRENGTH PREDICTION
OF STRESS GRADED STRUCTURAL TIMBER

by

P. Glos

Lehrstuhl Baukonstruktion und Holzbau
Technische Universität München
Federal Republic of Germany

LILLEHAMMER

NORWAY

MAY/JUNE 1983

INTERNATIONAL COUNCIL FOR BUILDING RESEARCH STUDIES AND DOCUMENTATION

WORKING COMMISSION W18 - TIMBER STRUCTURES

NOTES ON SAMPLING AND STRENGTH PREDICTION
OF STRESS GRADED STRUCTURAL TIMBER

by

P. Glos

Lehrstuhl Baukonstruktion und Holzbau
Technische Universität München
Federal Republic of Germany

LILLEHAMMER

NORWAY

MAY/JUNE 1983

ABSTRACT

There are various factors that influence the quality of estimating characteristic stress values. Among these are the definition of the specific population about which inferences are to be made, decisions about the sampling method and the sample size as well as the statistical definition of the characteristic stress value and the choice of the statistical model used for its computation.

For many of the decisions mentioned above the statistical theory does not offer satisfactory decision rules. Hence in some cases the engineer must decide intuitively. Regarding the harmonization of codes and standards it would be helpful if such decisions were standardized internationally.

As a contribution to the discussion of this topic this paper summarizes the potential errors that may arise when estimating the 5 percent exclusion limit and tries to assess their magnitude as a function of the sample size and of the underlying statistical assumptions.

1 INTRODUCTION

When characteristic stress values are to be evaluated experimentally, there are, among other things, three questions that have to be answered first:

- How many pieces of lumber do I sample?
- How do I sample these pieces of lumber?
- How do I interpret the test results, which statistical inferences can be made?

As a prerequisite it is mandatory that the objective of the experiment be defined as precisely as possible. Thus the sampling plan and the statistical methods for the analysis of the data have to be established so that within the scope of given economic circumstances the inferences to be made are as accurate and as precise as possible, i.e. that potential systematic and random errors are reduced as much as possible.

Essentially there are five possible sources of error (cf. Fig. 1):

- e1: The definition of the population including the difficulty involved in inferring from one subpopulation -the sample- to other subpopulations -e.g. the timber likely to be obtained from one source and used in one structure- (cf. e.g. Madsen 1978, Warren 1979, Fewell 1982).
- e2: The sampling plan. Due to its limited size no sample, not even a so-called 'representative' one, exactly represents its population. The degree of statistical uncertainty partly depends on the size of the sample (cf. e.g. Madsen a. Nielsen 1978, Curry a. Fewell 1981, Pellicane a. Bodig 1981).
- e3: The testing methods including systematic errors due to specific testing conditions and random errors due to

the accuracy of the measurements taken.

- e4: The data modification, i.e. the potential deficiency of some of the modification factors (cf. e.g. Madsen 1975 and 1978).
- e5: The statistical analysis. Depending on the statistical models used, i.e. the assumption of the underlying distribution function and the statistical definition of the exclusion limit, different results can be obtained from the same data set (cf. e.g. Tory 1975, Warren 1979, Johnson 1980, Glos 1981).

In the following the problems related to the sampling of the material and to the statistical analysis are discussed. Moreover an attempt is made to assess the magnitude of the respective uncertainties. Finally the problems caused by the adequate definition of the specific population about which inferences are to be made, will be discussed.

2 EVALUATION OF THE 5% EXCLUSION LIMIT OF A SPECIFIED POPULATION WITH UNKNOWN DISTRIBUTION

2.1 General

Today it is generally accepted that the lower 5 percent exclusion limit is used as a characteristic stress value (i.e. as a basic reference point for the derivation of design stresses). However, researchers interested in the behaviour of systems and/or in probabilistic modeling of structures need to know more about the strength distribution than this single value.

The evaluation of an exclusion limit requires the assumption of an underlying statistical model. Hence the exclusion limit

is a conditional value, it cannot be determined unequivocally. In the past 10 years this aspect has been subjected to serious scrutiny, but today different methods for the computation of an exclusion limit from test data are still in general use (cf. e.g. Warren 1979, Johnson 1980). The choice of one of these methods depends on two decisions:

- The assumption of a hypothesis regarding the type of the probability distribution function of the underlying population or the decision for a nonparametric approach, resp.; and
- the choice of a confidence level associated with the estimation of the exclusion limit.

2.2 Influence of the confidence level

From a statistical point of view one must distinguish between a so-called point estimate and a so-called lower tolerance limit. When a *point estimate* is applied, the exclusion limit is thus estimated that *on the average* it corresponds with the true, however unknown, population 5th percentile. Consequently, with a single sample, it has an almost equal chance of lying on either side of the population value. It is not usual to associate a confidence level with this estimate; however, its value would be approximately 50 percent.

A *tolerance limit* is constructed so that it has a *specified confidence* of lying below the population 5th percentile. If, say, a 95 percent confidence level is chosen (cf. e.g. ASTM D 2915-74) then, *on the average*, 95 times out of 100 the calculated tolerance limit will fall below the true population value and 5 times out of 100 it will exceed it. A tolerance limit is a function of the sample size, in opposition to a

point estimate. As the statistical uncertainty inherent in the estimation and hence, on the average, the distance between the lower tolerance limit and the true population value decreases with increasing sample size, on the average an increased sample size gets 'repaid' by means of a higher value. However, a tolerance limit is more conservative on principle than the corresponding point estimate. These values are not directly comparable.

The distinction between a point estimator and a tolerance limit should be borne in mind when it comes to the determination of partial safety coefficients for a design code. If the same partial coefficients are to be used for different materials and the exclusion limits are defined differently for different materials, then materials to which the tolerance limit approach is applied would be handicapped.

Utilizing the results of a computer simulation, the influence of the confidence level on the estimation of the exclusion limit was examined as a function of different assumptions concerning the distributional form of the underlying population. In all cases qualitatively similar results were obtained, therefore only two cases are presented here. Fig. 2 shows the results for a normally distributed population, Fig. 3 shows the results for a population that follows a three parameter Weibull distribution. In all cases under investigation the population mean and standard deviation was 40 MPa and 10 MPa, resp., and the location parameter was chosen to be 15 MPa, if applicable. The true population 5th percentiles are 23.5 MPa for the normal and 24.3 MPa for the Weibull distribution.

From each population samples of size $n = 25, 50, 100$ (50) 400, 100 samples each, i.e. 9 x 100 samples, were drawn at random.

From each sample the 5 percent exclusion limit was determined as a point estimate and as a lower tolerance limit with a confidence level of 75 and 95 percent¹. Figs. 2 and 3 show as a function of the sample size the minimum and maximum estimates out of 100 samples and the mean estimates calculated from these 100 samples.

Remarkable is the large variability of the individual estimates. The dispersion decreases with increasing sample size in a decreasing manner; beyond a sample size of 300 the decrease becomes insignificant. The dispersion is roughly the same for the point estimator and for the tolerance limits, but by definition roughly 75 resp. 95 percent of the tolerance limit values lie below the population 5th percentile and therefore, on the average, underestimate the population value seriously even with large sample sizes.

Depending on the underlying distribution, the increase of the mean curve of the tolerance limit with associated confidence level of 75 percent becomes insignificant beyond a sample size of $n = 100$ to 200. This means that beyond that sample size a larger sample will no longer get 'repaid'.

¹In the case of a normally distributed population a lower tolerance limit can be derived directly from the non-central t distribution; extensive tables exist for many years (e.g. Owen 1963). A method to derive lower tolerance limits for a three parameter Weibull distribution was not yet available (Haskell 1981, Fewell 1982). The calculations mentioned here were based on a procedure developed by P. Glos and K. Schrupp. A paper on this subject is under preparation (Glos a. Schrupp 1983).

2.3 Influence of the statistical model

If the distribution function of the underlying population is unknown, the likely distribution function has to be assessed from existing empirical data. Hereby it must be borne in mind that the distribution of a sample may at random differ from the distribution of the population and that, in addition, this distribution does not necessarily follow one of the available mathematical distribution functions. Moreover, there is no satisfactory procedure available how to select the most appropriate distribution function.

As no parametric assumption can be proven to be in accordance with reality, it appears advisable to handle those assumptions with care.

The influence of the statistical model used was examined as well by means of a computer simulation. The underlying population was assumed to follow either a

- normal
- 3 parameter Weibull
- lognormal or a
- 3 parameter lognormal

distribution function, each being characterized by a population mean and standard deviation of 40 MPa and 10 MPa, and a location parameter of 15 MPa, if applicable. The population 5th percentiles are 23.5 MPa, 24.3 MPa, 25.9 MPa and 27.3 MPa, respectively. From each population samples of size $n = 25, 50, 100$ (50) 400, 100 samples each, i.e. a total of $4 \times 9 \times 100$ samples, were drawn at random. From each sample the 5 percent exclusion limit was determined as a

- nonparametric estimate²

²footnote see next page

and as a

- parametric estimate, assuming either a
 - normal
 - 3 parameter Weibull or a
 - lognormal

distribution function to be the correct model.

Fig. 4 shows the results for a normally distributed population, Fig. 5 shows the results for a population that follows a three parameter Weibull distribution. These two figures show, as a function of the sample size, the minimum and maximum *point estimates* out of 100 samples and the mean point estimates calculated from these 100 samples.

These figures indicate that the considerable variability of the estimated values is further increased in case the underlying model is incorrect. The curves of the mean values show that an incorrect model assumption may yield a systematic error, independent of the sample size. Moreover, these figures show that the nonparametric estimate is not inferior to a parametric estimation, at least if the sample size exceeds $n = 100$.

As the underlying distribution generally is unknown, an important point for the valuation of the different statistical models is the error that occurs when they are applied to

²The calculation was based on the nearest order statistic that did not exceed the corresponding theoretical value. An interpolation between two values was not carried out. In some cases this leads to an underestimation which, however, is only significant at a small sample size.

different underlying distribution functions. Fig. 6 shows how the *point estimates* of the 5 percent exclusion limit, based on a sample size of $n = 200$, deviate from the true population 5th percentile, if the above mentioned statistical *models* are applied and the *underlying population* follows either a normal, a 3parameter Weibull, a lognormal or a 3 parameter lognormal distribution. Fig. 6 shows the ratio of the estimated to the true 5th percentile, again for the minimum and maximum values out of 100 samples and for the mean values calculated from these 100 samples.

This figure shows that the incorrect assumption of normality yields a very conservative estimate. On the other hand, the incorrect assumption of a lognormal distribution may yield unsafe values that exceed the true value by roughly 5 percent if the underlying population follows a normal or a 3 parameter Weibull distribution. *On the average* the smallest systematic error is obtained if either a nonparametric estimate is used or, due to its flexibility, the 3 parameter Weibull model is applied.

3 NOTE ON THE DEFINITION OF THE POPULATION

From in-grade tests with full-size structural timber it is well-known that timber originating from different growing areas or stands may exhibit significant differences in strength under otherwise same conditions (grade, size, moisture content etc.). In addition the strength properties can be affected by the manufacturing process (sawing pattern, kiln-drying procedure etc.). There are many papers that refer to this aspect.

Resulting from this, the strength values of timber from *different* mills, as well as from *one* mill, if produced at

different time periods, may differ significantly. This situation is shown schematically in Fig. 7. This raises the question whether a characteristic stress value should represent the 5 percent exclusion limit for the entire population within e.g. the scope of a design code or rather the time and space dependent 5th percentile of an individual sample likely to be delivered to an individual consumer and/or to be used in one structure.

Naturally the answer to this question defines the sampling method and therefore has to be clarified at the very beginning. In doing this, three aspects have to be considered:

- With regard to the reliability and to the economy of structures, as well as with regard to liability problems, the knowledge and consideration of individual strength values is desirable. On the other hand, from the code writing point of view, especially with regard to simple, feasible design rules, it is desirable to define the population as extensive as possible, at best in accordance with the scope of the design code.

- A characteristic stress value should not be defined independently of the global safety concept, i.e. independent of the partial safety coefficients included explicitly or implicitly in the appertaining design code. With regard to the international harmonization efforts that cover all important building materials, one should try to come to a unified interpretation of these values. Within the field of other building materials it is common use, to specify a characteristic stress value as the 5 percent exclusion limit of the entire production within the scope of the corresponding design code, to limit unconservative deviations of individual samples by means of an adequate quality control procedure and to

assume that a certain tolerated unfavourable deviation of the material properties from their characteristic values is covered by the corresponding partial safety coefficient.

- The determination of a characteristic stress value is aimed at the establishment of a design value, as a basis for future engineering tasks. To this purpose the value is extrapolated implicitly into the future. However, an extrapolation necessarily requires either stationarity or at least *predictable* instationarity of the population in question and this does not come true for the timber supply, if freedom of trade and technological development are to be maintained. Consequently, the derivation of a characteristic stress value requires more than an analysis of the present or past situation with common statistical methods.

4 SUMMARY AND CONCLUSIONS

(1) As long as the stationarity of the in-grade strength properties cannot be guaranteed by the help of adequate grading rules, a population cannot be defined unequivocally. Consequently a characteristic stress value evaluated on the basis of the present timber supply is not necessarily representative for future situations.

(2) The quality of the estimation of a lower 5 percent exclusion limit of a specified population is essentially determined by three factors:

- the sample size, which affects the random dispersion of individual estimates. If the population follows a 3 parameter Weibull distribution the amount of this random dispersion is $\pm 12\%$, $\pm 8\%$ and $\pm 6\%$ for sample sizes of $n = 100$, 200 and 300 , resp. (cf. Figs. 3 and 5).

- the assumption of the underlying statistical model. An incorrect model assumption further increases the random dispersion of individual estimates and in addition it may yield a systematic error. If the population follows a 3 parameter Weibull distribution and the sample size is $n = 200$, the random dispersion may be increased from $\pm 8\%$ to $\pm 12\%$ and the systematic error may come up to 4% (cf. Figs. 5 and 6).
- the choice of the confidence level. With an increasing confidence level the estimate becomes more conservative. With a very large sample size the estimate asymptotically approximates the true population value independent of the confidence level. However, if the population follows a 3 parameter Weibull distribution and tolerance limits are estimated with a confidence level of 75 respectively 95 percent from a sample of size $n = 200$, then these values still underestimate the true population value systematically by 3 resp. 6% (cf. Fig. 3).

(3) Following conclusions can be drawn from the results of this study:

- At a given sample size the predominant amount of the variability of individual estimates must be attributed to the method of *random sampling*. It seems especially important to investigate to what extent this dispersion may be reduced by utilizing the method of 'stratified' sampling and by including available a priori information.
- A criterion for a 'tolerable' between-manufacturer variability might be the variability of random samples from one population.
- If 'random' samples are used, a sample size of $n = 200$ seems to be necessary (cf. Madsen 1978, Fewell 1982). If the condition given in ASTM D2915-74, Sect. 5.5.2

viz.

$$\frac{EL - TL}{TL} \leq 0.05$$

where EL denotes the point estimate and
TL denotes the tolerance limit

is applied to a 3 parameter Weibull distribution and a confidence level of 95 percent (cf. Fig. 3), then a sample size of roughly $n = 250$ is obtained.

- If there are no strong arguments in favour of a specific distribution, then it appears advisable to either assume a 3 parameter Weibull distribution or to apply a non-parametric method. In any case, the nonparametric sample 5 percent exclusion limit should be calculated as a control value.
- If the exclusion limit is estimated as a lower tolerance limit with a confidence level that exceeds 50 percent, then this specific information should be borne in mind when setting standards.

5 REFERENCES

- American Society for Testing and Materials 1974: Standard method for evaluating allowable properties for grades of structural lumber. ASTM D2915-74
- Curry, W.T., Fewell, A.R. 1981: Grade stress values for timber. Paper presented at ad hoc meeting on standardization of stress grading and finger-jointing of coniferous sawn timber, Geneva, June 1981
- Fewell, A.R. 1982: Notes on the determination of characteristic stress values for timber. Proceedings meeting of IUFRO S5.02 Wood Engineering Group, Borås, Sweden, May 1982

- Glos, P. 1981: [On the modeling of strength behaviour of structural lumber in compression, tension and bending]. In German. Techn. Universität München, Berichte zur Zuverlässigkeitstheorie der Bauwerke, No. 61
- Glos, P., Schrupp, K. 1983: Estimation of approximate lower tolerance limits for the three-parameter Weibull. In preparation.
- Haskell, J.H. 1981: Specific Weibull distribution concerns. From 'Metal Plate Wood Truss Conference' published by Forest Products Research Society, Madison, WI, 52-64.
- Johnson, R.A. 1980: Current statistical methods for estimating lumber properties by proofloading. Forest Products Journal 30(1980),1, 14-22.
- Madsen, B. 1975: Strength values for wood and limit states design. Canadian J. of Civil Engineering 2 (1975), 3, 270-279.
- Madsen, B. 1978: In-grade testing - problem analysis. Forest Products Journal 28(1978), 4, 42-50.
- Madsen, B., Nielsen, P.C. 1978: In-grade testing. Accuracy and confidence. Computer simulation. Structural Research Series No. 21, The University of British Columbia, Vancouver, B.C.
- Owen, D.B. 1963: Factors for one-sided tolerance limits and for variables sampling plans. Monograph SCR - 607, Sandia Corp., Albuquerque, N.M.

Pellicane, P.J., Bodig, J. 1981: Sampling error in the bending strength distribution of dimension lumber. Wood Science and Technology 15 (1981), 211-225.

Tory, J.R. 1975: The description of timber strength data. Proceedings CIB-W18 meeting, Karlsruhe, Germany, October 1975, Paper No. 5 - 6 - 2.

Warren, W.G. 1979: A critical examination of the statistical techniques available for estimating exclusion limits from in-grade tests. Forintek Canada Corp., WFPL, Technical Report No. 9.

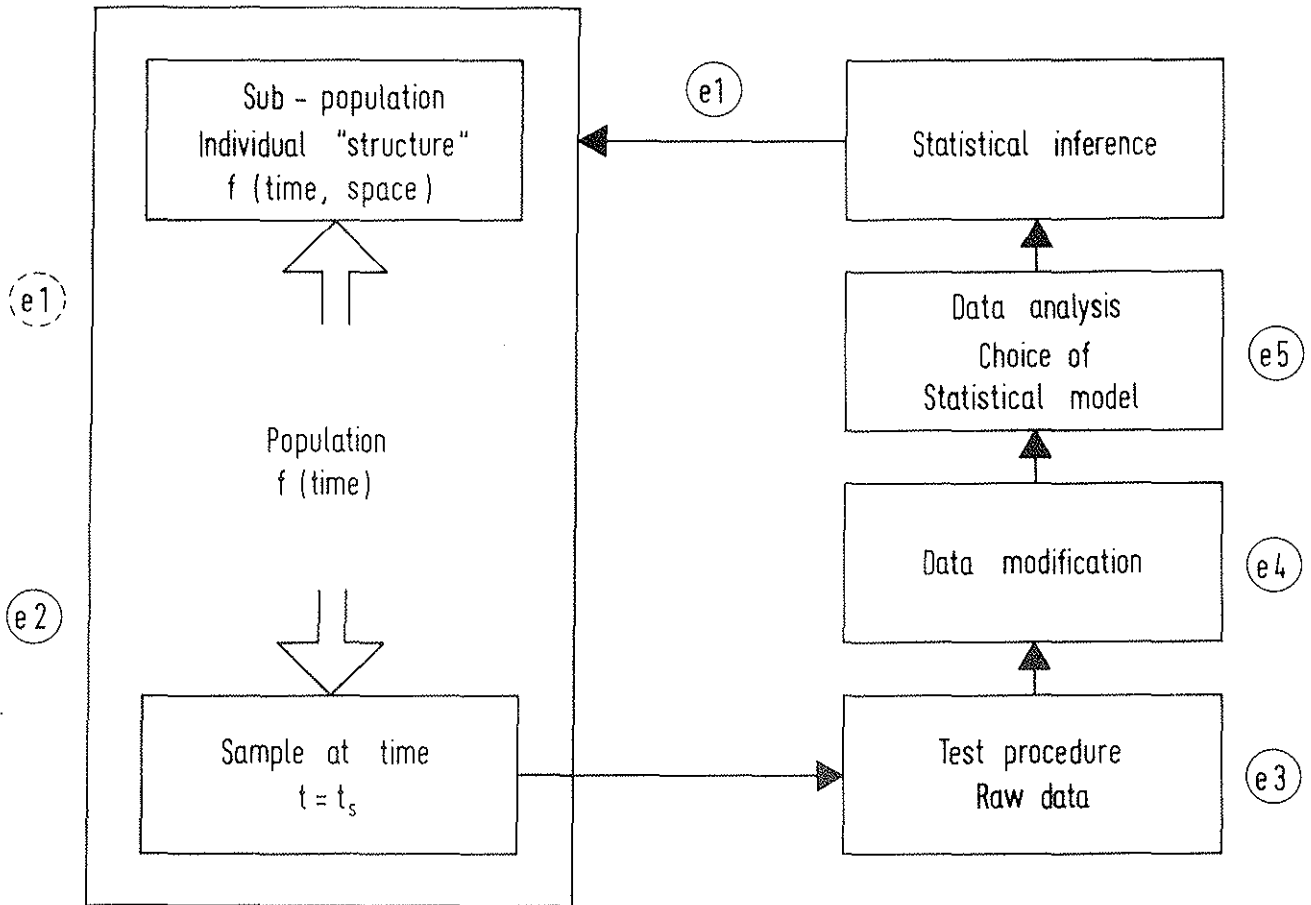

Fig. 1: Strength prediction of timber; potential sources of error

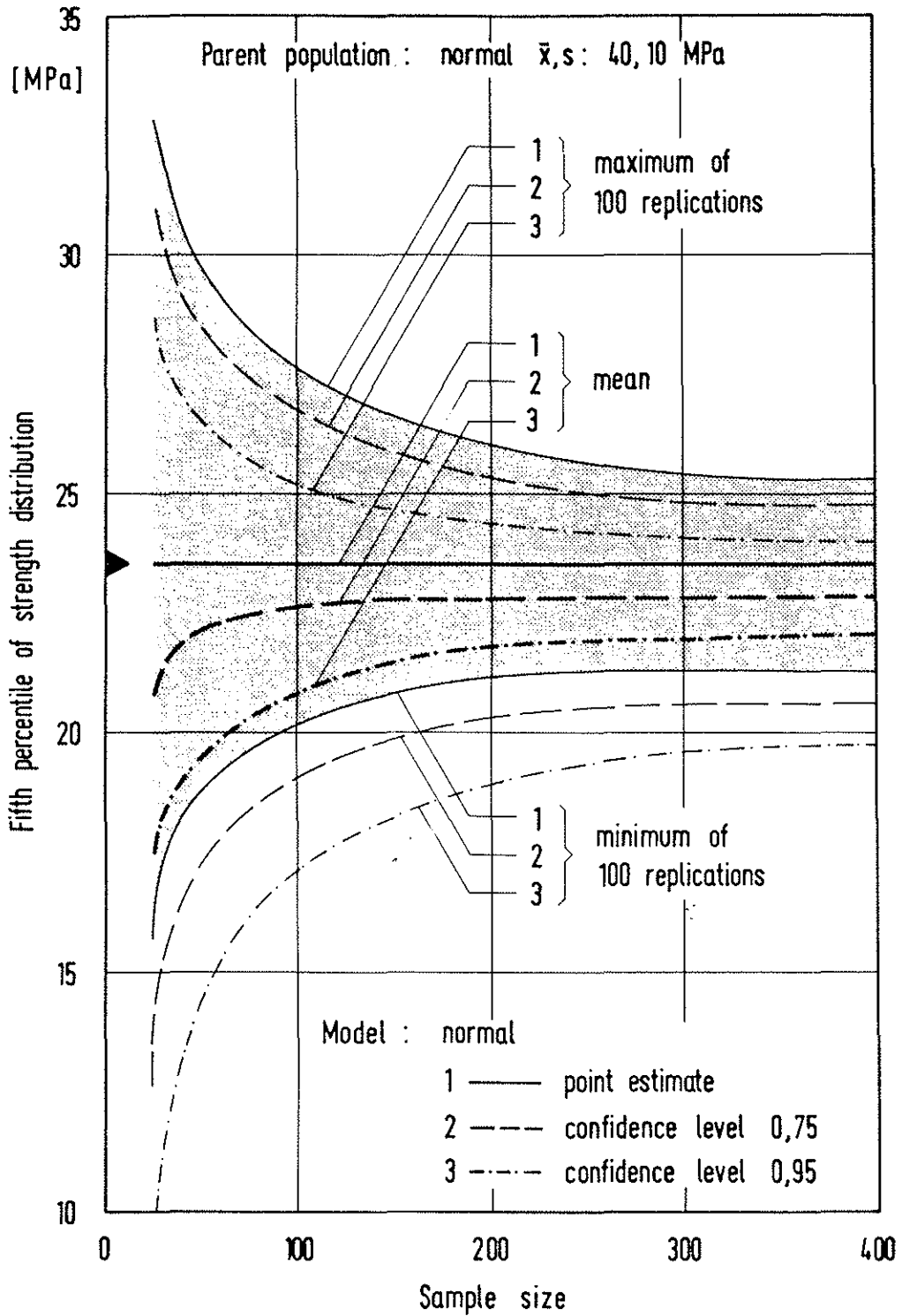

Fig. 2: Estimate of 5 percent exclusion limit as dependent on sample size and confidence level. Simulation results. Population: normal

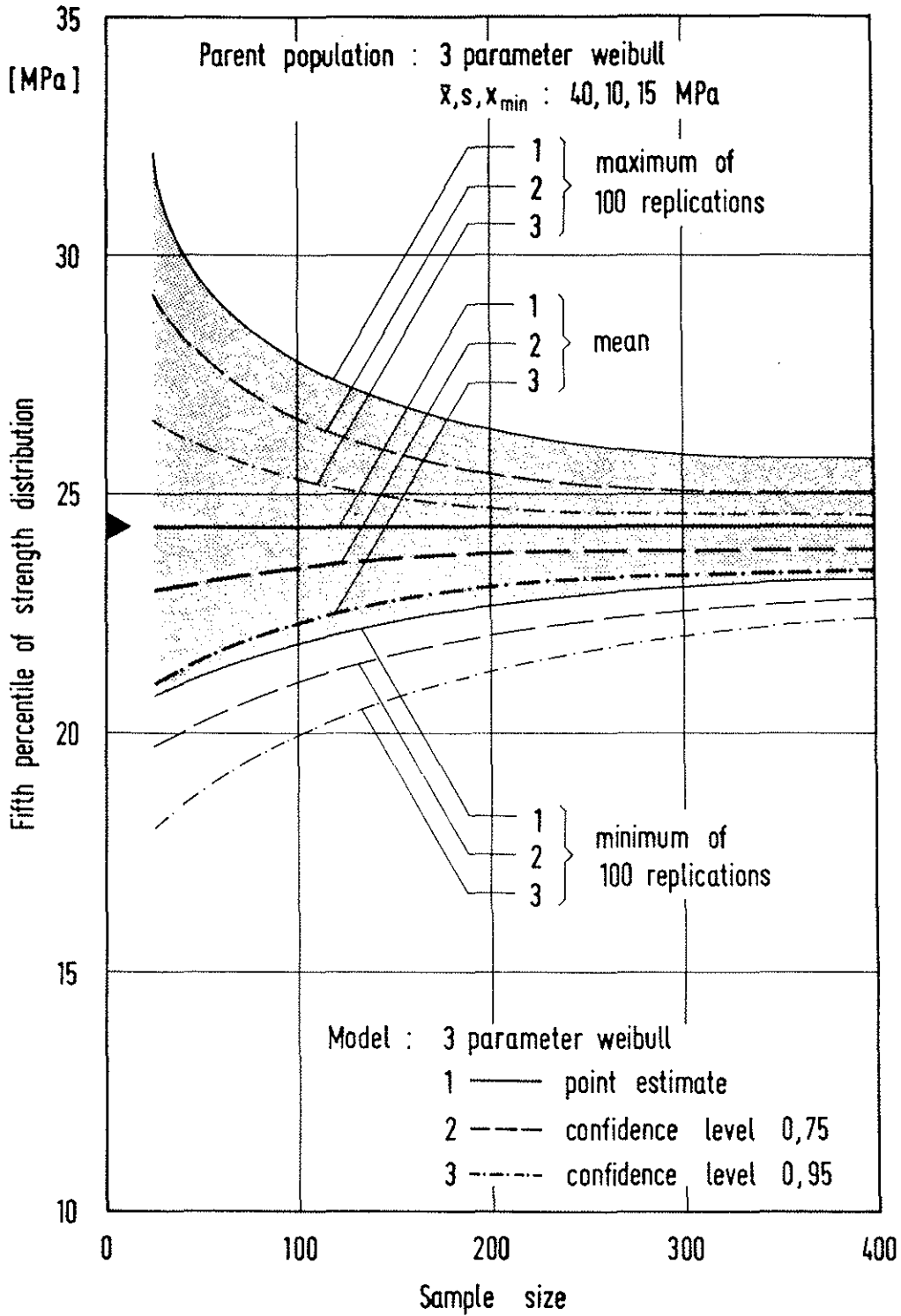

Fig. 3: Estimate of 5 percent exclusion limit as dependent on sample size and confidence level. Simulation results. Population: 3 parameter Weibull

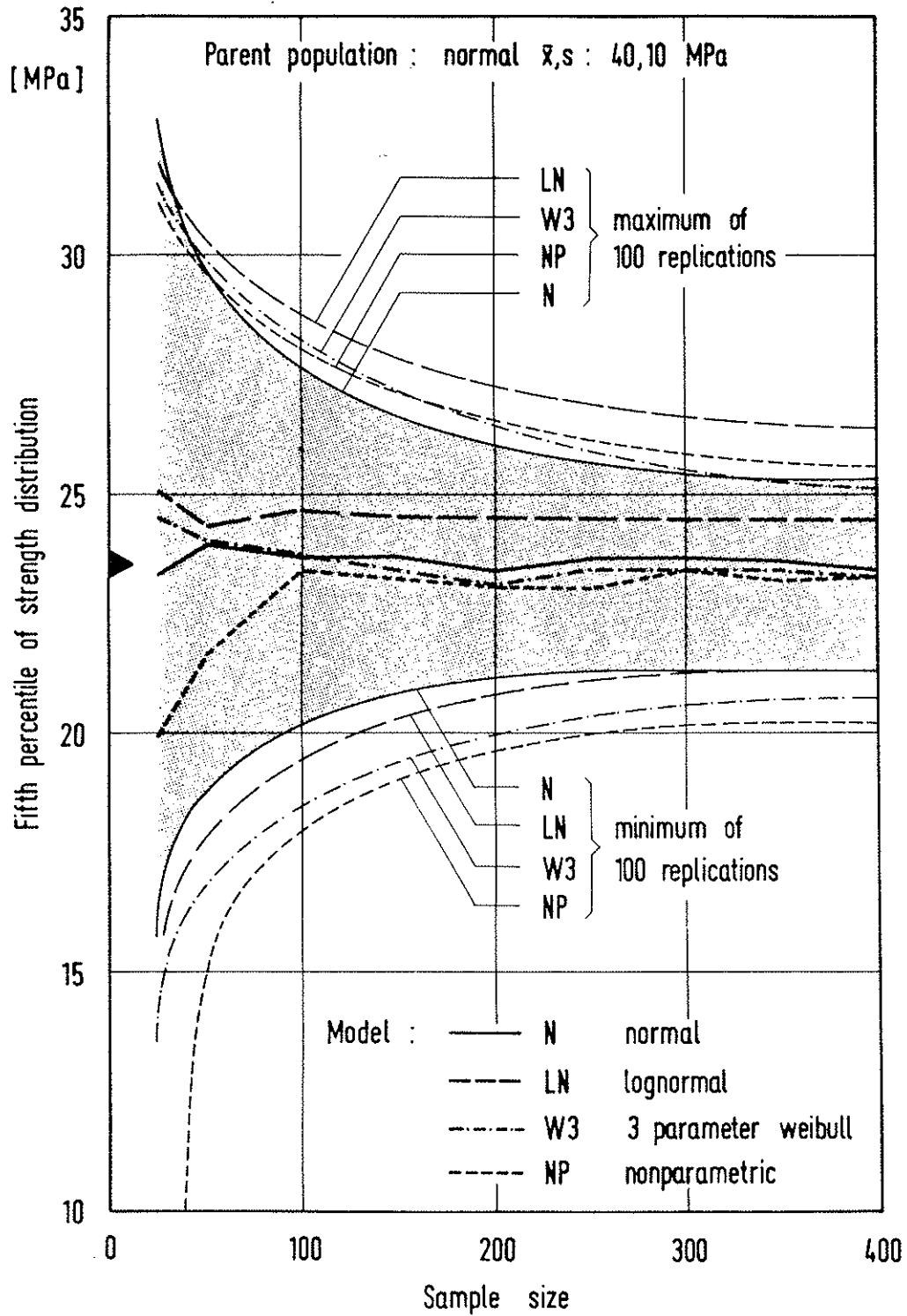

Fig. 4: Point estimate of 5 percent exclusion limit as dependent on sample size and statistical model used. Simulation results. Minimum, maximum value and mean of 100 replications. Population: normal

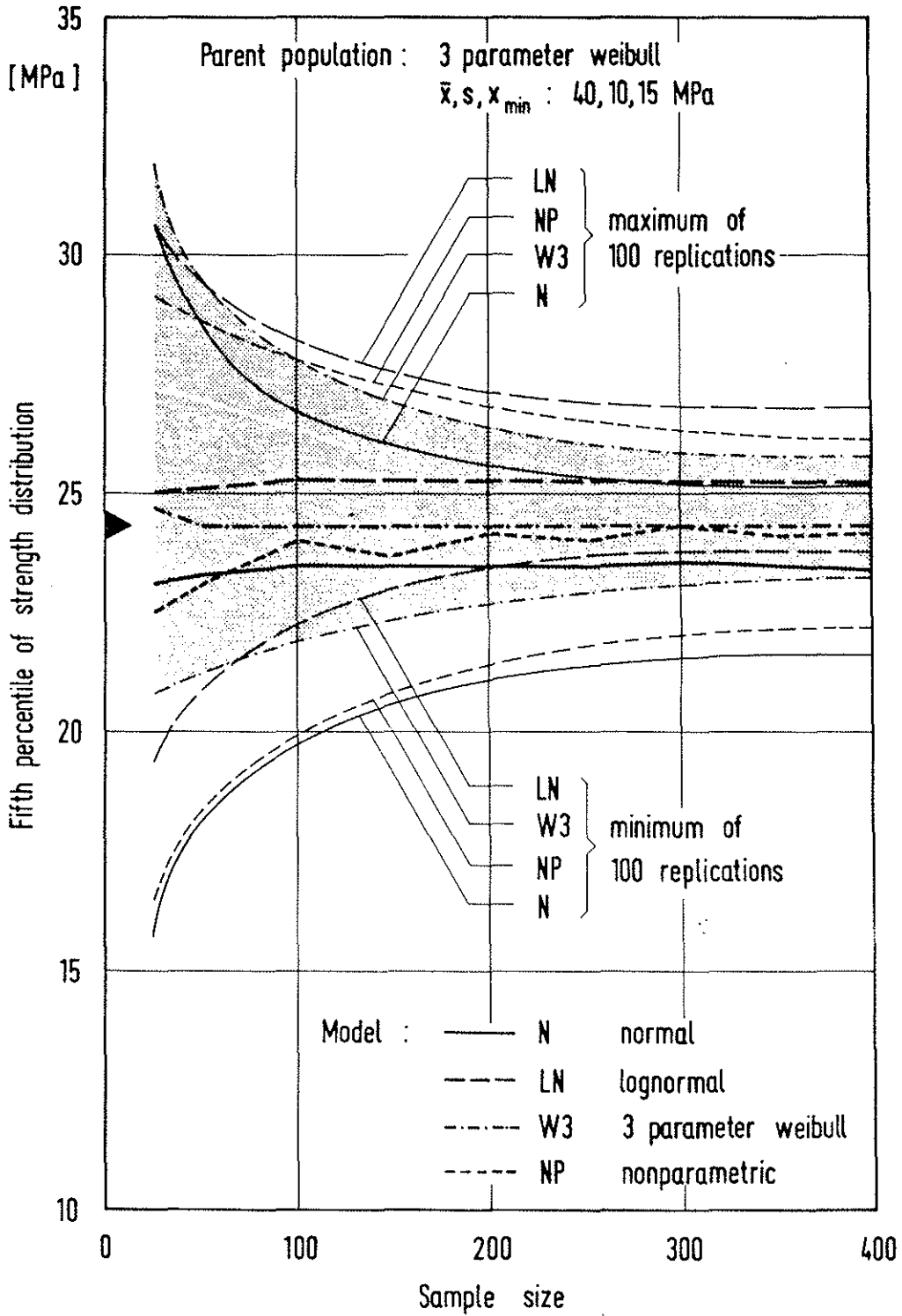

Fig. 5: Point estimate of 5 percent exclusion limit as dependent on sample size and statistical model used. Simulation results. Minimum, maximum value and mean of 100 replications. Population: 3 parameter Weibull

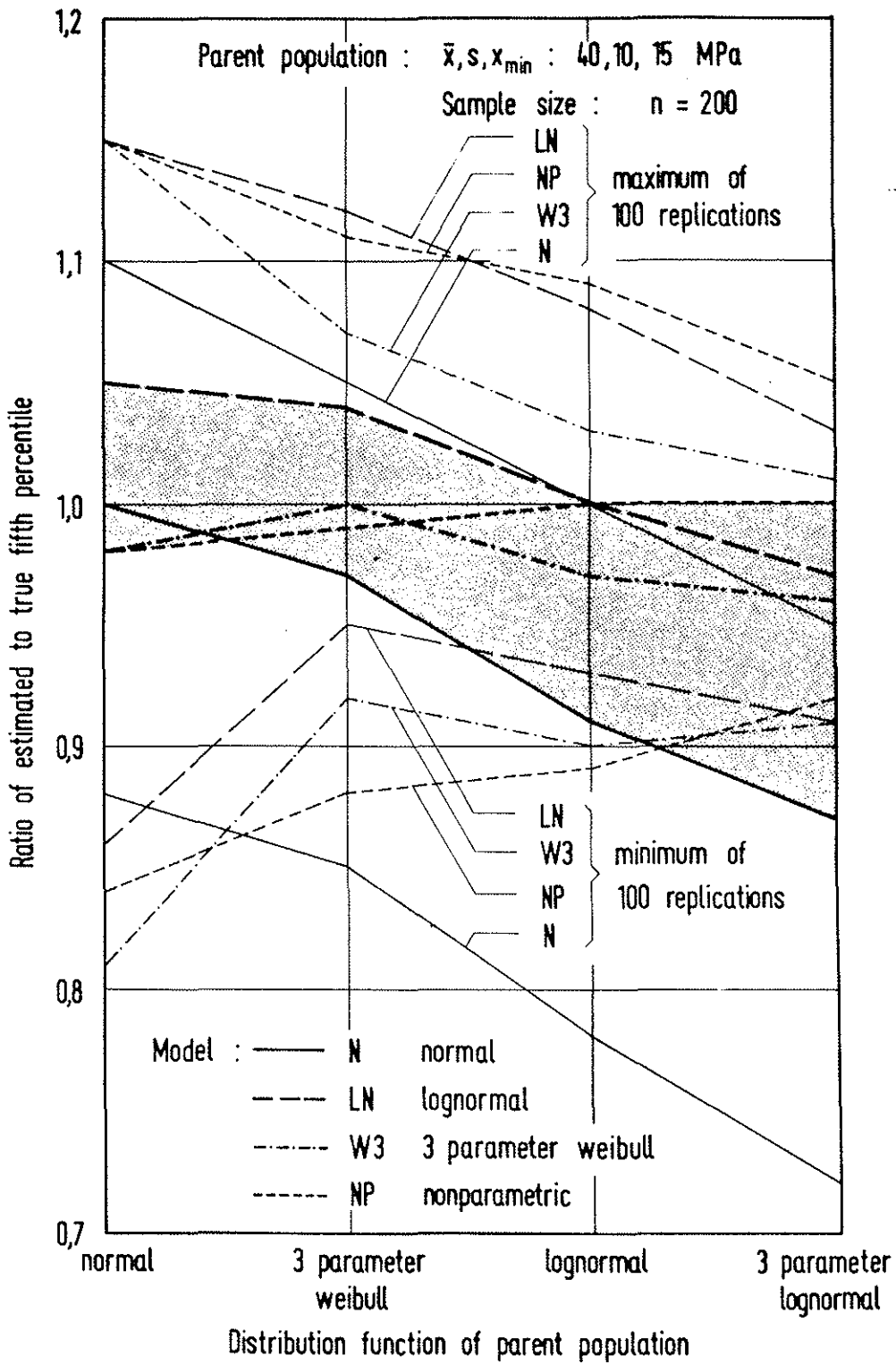

Fig. 6: Ratio between estimated and true 5 percent exclusion limit (point estimate) as dependent on statistical model used. Simulation results, sample size $n = 200$. Minimum, maximum value and mean of 100 replications.

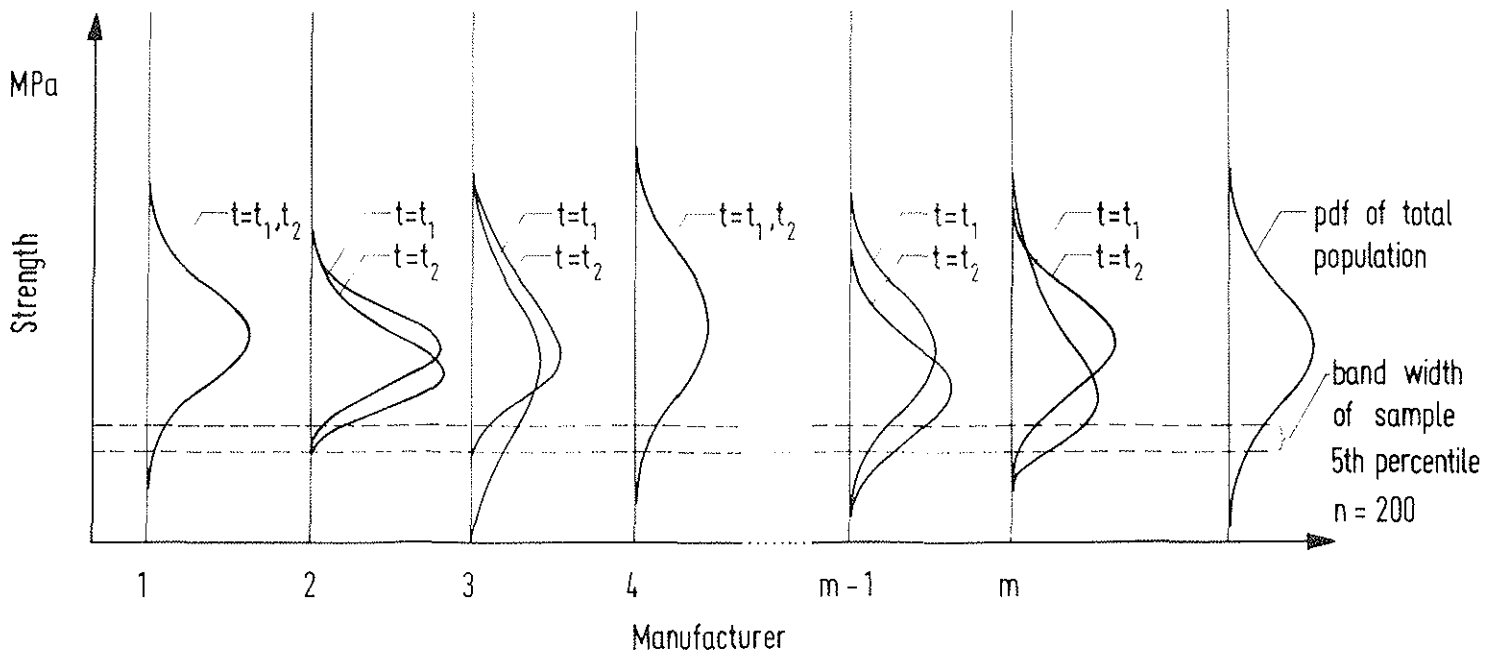

Fig. 7: Schematic representation of temporal and spatial variability of strength distribution.

INTERNATIONAL COUNCIL FOR BUILDING RESEARCH STUDIES AND DOCUMENTATION
WORKING COMMISSION W18 - TIMBER STRUCTURES

SAMPLING TO PREDICT BY TESTING THE CAPACITY
OF JOINTS, COMPONENTS AND STRUCTURES

by

B Norén

Swedish Forest Products Research Laboratory
Sweden

LILLEHAMMER
NORWAY
MAY/JUNE 1983

INTERNATIONAL COUNCIL FOR BUILDING RESEARCH STUDIES AND DOCUMENTATION
WORKING COMMISSION W18 - TIMBER STRUCTURES

SAMPLING TO PREDICT BY TESTING THE CAPACITY
OF JOINTS, COMPONENTS AND STRUCTURES

by

B Norén

Swedish Forest Products Research Laboratory
Sweden

LILLEHAMMER
NORWAY
MAY/JUNE 1983

INTERNATIONAL COUNCIL FOR BUILDING RESEARCH STUDIES AND DOCUMENTATION
WORKING COMMISSION W18 - TIMBER STRUCTURES

SAMPLING TO PREDICT BY TESTING THE CAPACITY
OF JOINTS, COMPONENTS AND STRUCTURES

by

B Norén

Swedish Forest Products Research Laboratory
Sweden

LILLEHAMMER
NORWAY
MAY/JUNE 1983

SAMPLING TO PREDICT BY TESTING THE CAPACITY OF JOINTS, COMPONENTS AND STRUCTURES

Background

During the last ten years the working group CIB-W18 has concentrated on an European model code for timber structures: CIB Structural Timber Design Code /1/. Design methods are dominating in this code in terms of formulas for calculating deformation and strength of structures and structural components. Introductory are also presented strength classes for structural timber and glued laminated timber with the correspondent profiles of characteristic strength at different kind of stressing.

Additionally, CIB-W18 has dealt with methods of verifying characteristic values of stiffness and strength of material, joints, components and structures of wood. This work had been carried out in subgroups set up by CIB and RILEM rather informally. The results are passed as proposals to ISO, generally through the technical committee TC 165. It is essentially a matter of testing standards, but complicated by the introduction of authoritative requirements on testing conditions based on divergent opinions and code philosophies in different countries. Thus, the selection of material for the testing, as well as methods for deriving and transforming of characteristic values from the test results, have been discussed in detail. A proposal for selection of wood for the purpose of testing mechanical joints was accepted as a CIB/RILEM Timber Standard already in 1976 /3/. This standard has been applied in Sweden since then.

Otherwise, the matter of sampling for testing of components and structures has not been carried to a satisfactory solution. Possibly, an international agreement will have to be restricted to general principles.

Testing conditions

It is important that the aim of the testing is well defined before work on a standard is started. This has not always been sufficiently considered in the CIB/RILEM standardisation work. The term "pure testing standard" is here used for a standard in which stipulations for material, design, climate and type of loading is kept at a minimum, in order to make the standard open to as many applications as possible. Naturally, there is a limit set by the demand that the results must be realistic. However, stipulations in terms of limitations or supplements, which are necessary in the case the results are to be used for deriving characteristic capacity values for the structural code or official approvals in connections with the code, should preferably be separated from the pure testing standard. One good reason for this is that the conditions in practice deviate geographically and with the kind of use. Another reason is that when it comes to load bearing capacity safety will be more significant than in a "common" standard. Consequently, in certain countries the building authorities, not the standard institutes, are responsible for this kind of "approval rules", annexed to the building code. One advantage is the possibility of a close connection between rules for the selection of material for testing and the rules for quality control in future production. It is also evident, that for approval testing it is often sufficient to stipulate either a minimum or a maximum value, whichever gives a result "on the safe side", while in the pure testing standard the values are given without tolerance or between narrow limits.

Like many national structural codes the CIB timber code recognizes that testing may be chosen as an alternative to calculation when the capacity of components or structures are verified. The conditions for the two alternatives to give the same result, that is the same safety, have been outlined in a previous paper /4/. The demand that the testing object is well specified whether it consists of one or several units, is recognized by most testing standards. But the choice of object for the testing is introduced first in the case that the results shall be applied to other objects which are not tested. This is very much the case when the testing results are intended for the derivation of characteristic strength values

for objects which will be produced years after the testing is performed. The choice of material is significant at timber structures because the variations of the wood properties in future production may be considerable and difficult to predict. This is a problem of the same nature and magnitude as that of establishing general partial safety factors considering existing local and temporary variations in material. Similar problems concern the assumptions with regard to load and climate actions.

For the different steps in derivating characteristic values based on testing is refer to the CIB-W18 paper 6-7-4 /5/.

Selection of wood for approval testing

In the following sections and Appendix A is dealt only with the selection of wood for testing products with the aim of verifying load carrying capacity in terms of characteristic values to be introduced in a code of practice or a correspondent approval. Sampling for testing in connection with running quality control is outside the scope of the paper. This limitation generated two questions with reference to the title of the paper: Does sampling mean drawing samples (examples) from a population at random or by some system, for examination with the purpose of estimating one parameter or several parameters to describe properties of the population? Is "selecting material" synonymous to systematic (not random) sampling of material?

The answers were (H J Burgess): Yes respectively No with a comment "I think selecting material implies selecting it by any means, whether systematic or random". Accordingly, sampling and selecting are used as next to synonymous. Thus, sampling does not necessary imply statistical methods and the conclusions and proposals in the paper should be relevant to its head-line.

Approval based on type-testing may follow the following procedure:

1. The manufacturer defines the product when searching approval.
2. A small number of units, just about in correspondence to the definition, are tested.
3. The approving authority prescribes such quality control which gives sufficient probability that products manufactured in the future under the name of the approval will correspond to the definition.

According to this philosophy it is ultimately the manufacturer who decides what the material shall be in the products to be type-tested. This procedure works well for many products, but has caused problems in the case of approving wood structures. The most important reason for this is the contradiction of defining products in future manufacturing to testing a small number of products. Hypothetically one could define future productions based exactly on what has been tested. However, in practice this will merely submit the problem to the point of the quality control when the difficulty or even impossibility of reproducing the tested products will be evident. Eventually, the problem is referable to the difficulty of finding relevant grading criteria for structural wood and a practical and economical way of grouping such timber.

One may identify three principles for the selection of wood for type-testing of structures:

- | | |
|----------|--|
| Method 1 | The number of tested units is considerably increased, either in an attempt to simulate a "normal" distribution of wood properties (if it is possible to define what is "normal") or in order to establish test results on two or three levels of wood quality. |
| Method 2 | Selection of wood with uniform properties between as well as within members. |
| Method 3 | Go without testing. |

All three alternatives have been considered seriously. Advocates of Method 1 are generally referring to the kind of structures where failures are expected to appear in the members outside the connections. In many trusses and similar structures the static conditions are such that forces and moments in the members can be calculated confidently and the resistance of the structure to load directly related to the strength of the timber. Therefore, much of the testing performed on trusses has been nothing but testing of structural timber. It is then unacceptable that rules for testing and approval has made it possible to increase stresses in the timber by up to 20 % based on testing of 15 to 50 units, while a much smaller increase of code stresses for the same kind of timber will require 10 to 20 times that number of specimens.

There are reasons why one may expect higher capacity derived from testing results then from calculation based on the code. One is the "statistical effect" from the fact that timber strength is defined by the weakest cross-section along the piece without consideration to the high strength in other sections. However, the magnitude of this effect is dependent on the structural grade of the timber, the design of the structure and on the distribution of the load. In order to separate the statistical effect from deviation caused by other factors, theoretical analyzis and testing is required to an extent that will be unimaginable for approval testing.

The Method 2 is very different from the Method 1, the principle target being to reduce the deviation of strength and stiffness properties in the wood members. This indicates that the aim of a testing by Method 2 is to verify the performance and strength of the connections, rather than to compete with standard testing of timber. It could be said, that in this case one should select timber to a high grade with respect to knots and similar defects and also use the density criterion with reference to the joints. In the proposal, reproduced in Appendix A, one has not gone that far. The selection of the timber is referred to the grade limitation of minimum strength but additional stipulations are introduced in order to reduce the deviation along the member. Consequently the statistical effect is also reduced. Simultaneously, the additional stipulations will

lead to a reduced deviation of density which will make the information on the capacity of joints reproducible.

A concentration of the type-testing and approval on the design of joints and consequent static model for the structure, justifies the question why "cut out" connections cannot be tested in stead of structures. In many cases they can. This is a reason why the selection rules for joints and structures should preferably be conform with respect to the density of the wood.

Selection of wood for testing joints

In a comment to the "CIB-Timber Code" /1/ it was said that the "CIB-RILEM Timber Standard No. 07" on requirements of the timber and calculation of characteristic values has been prepared on the basis of a draft discussed and accepted in June 1976, namely "CIB-W18/paper 6-7-3". The decision at the meeting No. 6 of the CIB-W18 according to the minutes read: "it was agreed that paper 6-7-3 should be included in the Code although some amendments might have to be made to it in the future".

For the "No. 7" (here is referred to Draft No. 3 76.11.01) the requirements regarding the wood are limited to the density and the conditioning (climate). There is an option between two methods concerning the deviation of density from a characteristic value (ρ_k). The difference is:

In Method No. 1 is stipulated that at least 20 % of the tested joints must be of wood with a density lower than the characteristic value. Simultaneously, it is stipulated that the mean value of the density must not be less than 1.15 times the characteristic value. This means that the coefficient of variation at normal distribution should be at least 0.15 or that the distribution must be skewed to low density.

In Method No. 2 the requirement on deviation is much more restricted, stipulating that no individual value (density of an individual test specimen) shall deviate more than 10 % from the total mean value. The connection with the characteristic value is a stipulation that the mean value should fall between $1.05 \rho_k$ and $1.25 \rho_k$. This is more liberal than by Method No. 1 but then it should be observed that the joint strength values measured are supposed to be adjusted to the characteristic density value. This is not the case at Method No. 1.

What has been quoted here from the "CIB-RILEM Timber Standard No. 7" concentrates on controlling the deviation of the density of the wood selected for the joints to be tested. If the aim is to get reproducible results, such as when strength values are searched for different types or makes of fasteners, Method No. 2 is the superior one. The principles have

been applied for several years in the Nordic countries and the method is adopted by NORDTEST /7/.

Both methods are open to any level of density defined by the characteristic value ρ_k . With reference to European pine and spruce CIB-RILEM Timber Standard No. 07, Method 1, gives the value 0.36. The stipulation that at least 20 % of the tested joints may indicate that the value is a 20-percentile. However, if 0.36 is considered merely as a reference value, a series of such values could well be where a standard should come to a stop. The sampling process will thus start by that a value for ρ_k is chosen within the standard series. It will generally be an estimation within a species group, covering an extended population of wood which includes different sources and grading methods. In the paper 6-7-3 /6/ was referred to "softwood D400 (low density)" and "softwood D500 (high density)". Adding one value in the series this would correspond to the ρ_k -values 0.36, 0.45 and 0.56. When one is in doubt which of two adjacent values that will fit the anticipated application of the results best, the general rule would be either to choose the lowest value or to perform the testing at two levels of density. Testing at two different density levels is often to recommend, as a subsequent transformation of results to a higher level may be difficult if more than one mode of failure is involved.

Note

Sometime during the process of revising the "No. 07", a small discrepancy was introduced between the recommended density-values in Method 1 and Method 2. Preferably the Method 2 should read:

The wood should be selected thus that the density variation within groups of density is kept small:

No individual value should deviate more than 10 % from the total mean. The mean value of density within a density group should be between ρ_k and $1.25 \rho_k$. A standard geometric series of density values for selection of the wood for testing of joints is 0.36, 0.45, 0.56

Selection of wood for testing structures

As Appendix A to this paper is reproduced a proposal from 1981 for selection by machine of the wood to be used in structures for type-testing. It is called Method 2 and corresponds in aim and principles not only with the Method 2 previously mentioned as one of three solutions for the choice of wood to type-testing, but also with Method No. 2 of CIB-RILEM Timber Standard No. 7 for the selection of wood for testing joints. The most important section is repeated here:

"The wood shall be selected by a machine approved for MSG. The machine shall be set thus that, according to an approved program, the strength mentioned in what follows (a and b) may be expected in the parts of the wood, which are intended for the structures to be tested:

- a The minimum value of (local) strength within a piece of wood shall be at least 1.0 but not over 1.1 times the GL-value (grade limit value of strength).
- b The mean value of (local) strength within a piece of wood shall not exceed 1.25 times the GL-value."

The significance of these rules is illustrated by Figure 1. The range of the expected local bending strength is shown for 24 pieces of timber. A horizontal line connects the minimum value (right end of the line), the mean value (small circle) and the maximum value (left end of the line). Note that the strength is increasing from right to left in a non-linear presentation. (The deflection in the machine is linearly increasing from left to right).

The timber was used for trusses to be tested for approval. It was pre-graded visually, first into a mixture of o/s and V then in accordance with the rules for supplementary visual grading of machine graded (MSG) timber. Afterwards the timber was put through a Computermatic equipped to record the local deflections along the piece, 20-25 values. The machine would accept 85 % of the input in selecting T24 or better, that is, in an

ordinary commercial grading for T24. However, for selecting wood for type-testing purpose, the basic stipulation is that the strength must not be better than the grade value, in this case T24. Therefore, the minimum value of expected strength (right end of the line) must fall between the vertical lines GL24 and GL33. After such exclusion of 33 and better the yield of 24 should be about 30 %. However, in this case a special stipulation was added: only single local values were allowed to pass the boarder GL33. This could be satisfied, at least approximately, by checking the lights which indicated each boarder passage, while the piece went through the machine.

This additional requirement decreased the yield considerably. But, it was simultaneously tolerated that the minimum value just passed the boarder against the lower quality, T18. It is seen that this tolerance was applied to five pieces. The reason for accepting the pieces represented by dotted lines is not clear. Anyway, the final yield was 10 % of the timber put through the machine. This may appear a low yield, but as this only implies the cost of handling the timber, the prize is low for what is achieved - reduced deviation of strength within the grade.

How had it changed the results if Method 2 had been applied in stead of the temporary stipulations? The four pieces of timber giving the dotted lines should not be accepted by either method. That should also be the case with the pieces no. 2 and no. 12. These pieces passed by mistake in spite of both having six successive local values outside the boarder GL33. This does not directly appear from the figure, which does not show the distribution of the local values, but it is indicated by the position of the mean values. Actually, these two pieces (and another three) had been rejected by Rule b of Method 2, giving an upper limit for the mean strength. Rejecting pieces with local strength skewed to high values is the very purpose of the rule. As a matter of fact the piece number 12 would have been rejected anyway by rule a, stipulating that the minimum value should not be greater than 1.1 GL (26.4). Both these rules (a and b) contribute to rejection of timbers with relative high strength on a substantial length. Without the 1.1-rule it would be too easy to select timber close to the next higher strength class than aimed at. This is particularly the case when the members of the structure are short.

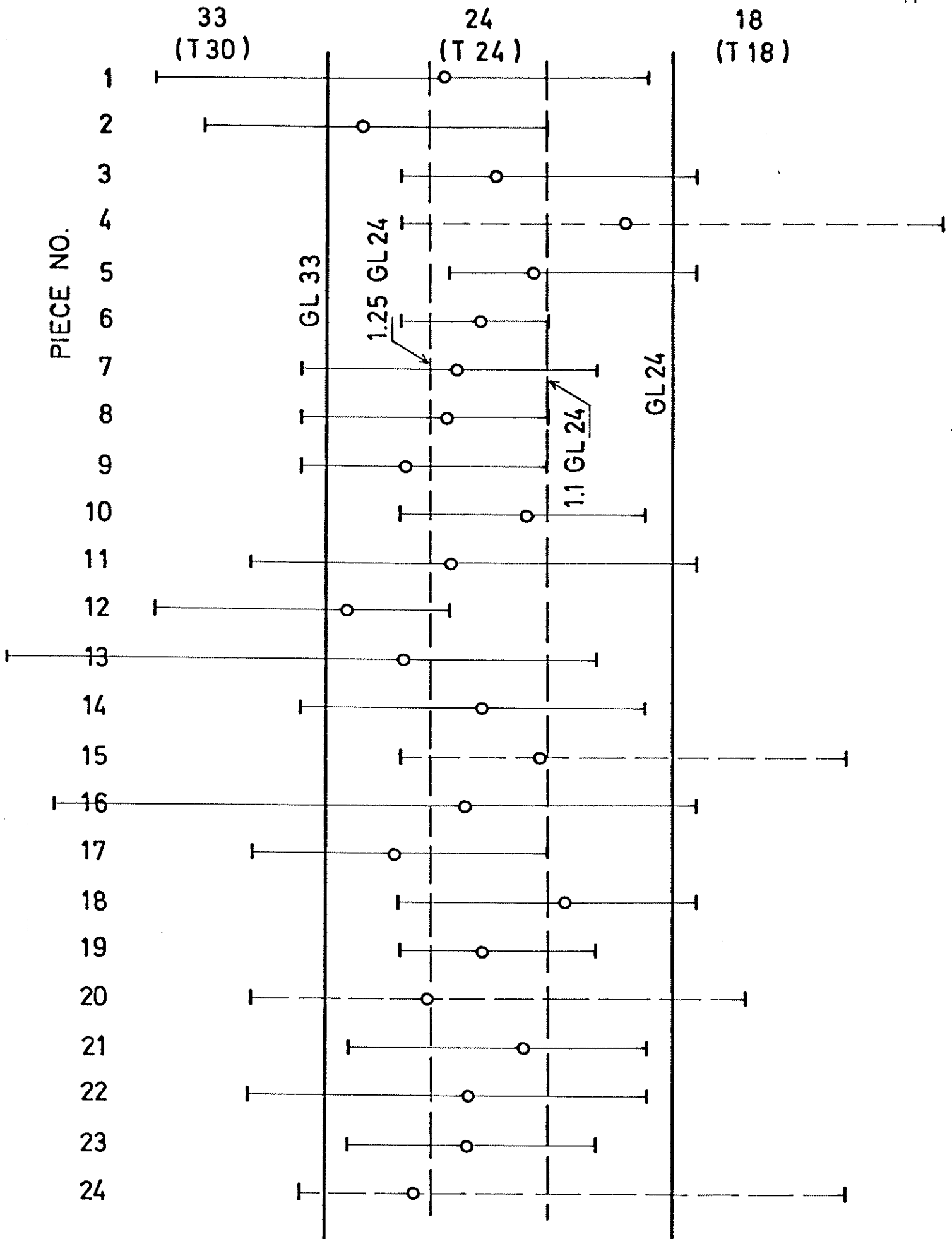

Figure 1. Deviation of strength within timber pieces selected for truss testing.

References

- /1/ CIB Structural Timber Design Code. Fifth edition, August 1980.
CIB-W18 Timber Structures.
- /2/ Annex 01 and 02 to /1/.
- /3/ CIB-RILEM Timber Standard No. 7. Draft No. 3 76.11.01.
- /4/ Norén B: Nachweis der Tragfähigkeit von Holzkonstruktionen durch
Berechnung oder Versuch. Ingenieurholzbau in Forschung und Praxis.
Bruderverlag, Karlsruhe, Juni 1982.
- /5/ CIB-W18 Meeting No. 6. Aalborg, June 1976. Paper 6-7-4.
- /6/ Dito. Paper 6-7-3.
- /7/ Nordtest method NT BUILD 133-136. Approved 1981-06.



SELECTION OF WOOD FOR STRUCTURES TO BE TESTED AS PROTOTYPES

Principle

These are rules for selection of the wood to structures which are to be tested for approval of, principally, load bearing capacity. Such capacity may concern the serviceability limit or the ultimate failure limit. Usually characteristic values of capacities of stiffness and strength are aimed at. Particularly the fact that the design generally must be based on a 5-percentile value of strength makes the selection of the wood intricate. Two different methods have been advocated:

1. The distribution of strength properties between wood members, expected in practice, is imitated.
2. A distribution is aimed at which has less deviation and is shifted to give a lower mean of wood strength than the distribution expected in practice.

Method 1 involves the problem of defining a distribution which is representative for the variations of strength of structural wood in practice. And should it be possible to agree upon a standard distribution, based on variations between and within wood pieces the number of structures to be tested in order to arrive at reproducible 5-percentile values will anyway have to be considerably great.

Method 2 should be simpler to apply and reproducible. That is, it is possible to repeat the testing under other conditions, such as other type of connectors, and expect results with negligible influence of the sampling of the wood.



It is here proposed that the selection of wood is based on Method 2. This is in agreement with the recommendations by NORDTEST for the testing of mechanical fasteners (nails, nail-plates) in joints. It is emphasized that the purpose is to restrict the variations of the wood, not to simulate the grading of wood found in practice. In the case the results of the testing are considered not directly applicable as substitute for the characteristic capacity of the structures in practice, they may be transformed to expected wood conditions by recognized statistical methods.

Scope of application

The rules for selecting wood for type-testing for approvals are principally applicable for complex structures, such as trusses or built up beams, etc. They are not intended for pure joint testing, for which is referred to special sampling rules (NORDTEST or similar). Although the rules may in principle be applied also at testing of simple beams and glued laminated beams, they are not suitable for testing of structural wood itself or laminated wood with the aim of deriving characteristic strength values. Should such testing be within the scope of type-testing, it at least calls for a Method 1 sampling.

Considered factors

The following factors are taken into consideration at the sampling of the wood:

1. Criterion at machine stressgrading (MSG).
2. Supplementary visual grading
3. Density
4. Moisture content (MC)
5. Finger joints

Stress grading by machine

It is assumed that a strength grade or class is prescribed and that a correspondent lower limit of the 5-percentile strength value is defined. This limit is here denoted GL = grade limit value of strength.

The wood shall be selected by a machine approved for MSG. The machine shall be set thus¹⁾ that, according to an approved program, the strength mentioned in what follows (*a* and *b*) may be expected in the parts of the wood, which are intended for the structures to be tested²⁾:

- a* The minimum value of (local)¹⁾ strength within a piece of wood shall be at least 1.0 but not over 1.1 times the GL-value.
- b* The mean value of (local) strength within a piece of wood shall not exceed 1.25 times the GL-value³⁾.

Note 1 In most stress grading machines the bending stiffness measured over a short length (0.5 to 1.0 m) is used to predict strength. The rules are not restricted to these machines.

Note 2 The machine stress grading is in most cases performed before the wood is cross cut to its final length. Hence, the grading must refer to the parts used in the structures to be tested.

Note 3 The aim for limiting the mean value of strength within a piece to 1.25 times the lower limit value of the grade is to avoid a large variation of strength within and between the members of the structure. Applied on the series of strength classes (grades) proposed by CIB-W18 the rule is equivalent to saying that the mean strength must not exceed the lower limit of the next higher class.

Supplementary grading

The wood shall preferably be stress graded by machine over the total length of the respective structural members. In the case the initial length does not allow the cutting away of ends not graded by machine,



the strength of these ends - estimated by recognized visual rules (BS 5268, T-timber rules) - should be equivalent to what is stated above for the strength of the main parts, graded by machine.

Limitations of features which are not included in the ordinary grading rules but which are specified for the structure to be approved by testing, must be considered at selection of the wood.

Note 4 It is appreciated that visual estimation of the strength at the ends is approximative. However, it is desirable that the wood towards the ends (0.9 m or less from the end) is not significantly stronger than the mean strength of the machine graded part. In other words, the estimated lowest strength within the visually graded parts at the ends of the wood piece should be in the range of 1.0 to 1.25 times the lower grade limit value. In particular, this is important if the wood is going to be fingerjointed.

Density

Wood for testing of structures with mechanical joints should have density adopted to rules for testing of joints. If the lower grade limit of bending strength does not exceed 24 MPa (T24, SS, ECE/26), the mean value of density of dry wood should not exceed 440 kg/m³ within an individual piece.

Moisture content

The moisture content of the wood intended for the structures to be tested must not exceed 0.22 (22 %) when selected by machine stress grading, should a higher M.C. not be prescribed for the testing of the structures.

Size

The cross section measures of the wood, selected for the structures to be tested, shall be within standard tolerances when graded. If the



structures shall be made from planed wood or wood processed in another way, the grading shall be performed at the final measures.

Finger-joints

If the approval sought shall concern structures in which finger-jointed timber is allowed, the grading for the selection of the wood may be performed before or after fingerjointing. At grading of already jointed timber, the demands for strength for "individual pieces" apply to parts between joints. Spacing of joints and the location of the joints in the structure is chosen with respect to what will be specified for the structures in the approval.

INTERNATIONAL COUNCIL FOR BUILDING RESEARCH STUDIES AND DOCUMENTATION
WORKING COMMISSION W18 - TIMBER STRUCTURES

DISCUSSION OF SAMPLING
AND
ANALYSIS PROCEDURES

by

P W Post

American Plywood Association
USA

LILLEHAMMER
NORWAY
MAY/JUNE 1983

INTERNATIONAL COUNCIL FOR BUILDING RESEARCH STUDIES AND DOCUMENTATION

WORKING COMMISSION W18 - TIMBER STRUCTURES

DISCUSSION OF SAMPLING
AND
ANALYSIS PROCEDURES

by

P W Post

American Plywood Association
USA

LILLEHAMMER

NORWAY

MAY/JUNE 1983

INTERNATIONAL COUNCIL FOR BUILDING RESEARCH STUDIES AND DOCUMENTATION

WORKING COMMISSION W18 - TIMBER STRUCTURES

DISCUSSION OF SAMPLING
AND
ANALYSIS PROCEDURES

by

P W Post

American Plywood Association
USA

LILLEHAMMER
NORWAY
MAY/JUNE 1983

DISCUSSION OF SAMPLING AND ANALYSIS PROCEDURES

P. W. Post: American Plywood Association, Tacoma, Washington USA - May 1983

There has been some interest in developing standardized procedures for sampling panel products and analyzing test results. Standardizing sampling and analysis procedures is likely to be much more difficult than standardizing the test specimen and test procedures. The objective is to provide data from which engineering properties can be determined suitable for use in building design. The difficulties arise because within this broad objective there is a tremendous range of size and uniformity of population to be sampled, the economic impact of the engineering properties to be derived, and funds available for conducting a sampling and testing program, and the degree of refinement needed. Within these constraints each research organization is very likely to continue to devise its own sampling scheme using a mixture of judgement and statistical techniques. It may be more to the point to standardize the end result expected from whatever sampling scheme is used, rather than to specify detailed schemes and statistical techniques for achieving them.

In my view there are two areas which could benefit from standardizing. The first relates to defining the confidence level with which the key characteristic values, such as the 5% for strength or the 30% level or mean for stiffness, are to be determined. This is needed if design values for use under the building codes are to achieve a uniform level of safety for the various materials.

Specifying the end result desired, rather than the specific sampling and analysis scheme for achieving it, has a number of advantages:

1. It leaves the material manufacturer or association free to select the most cost effective scheme considering the specific uses intended for the material. Thus, the required confidence level might be achieved by conducting a very thorough and expensive sampling and testing program aimed at obtaining the highest possible design stress levels for a demanding structural application. The same confidence level might also be achieved by conducting a very limited sampling and testing program for a material whose properties considerably exceed the requirements of the intended use. In this case there is no economic penalty for larger reductions required to offset the limited sample. Both options are legitimate and should be available.

2. The choice of statistical techniques to be used is left to the investigator. Both parametric and non-parametric methods are available. Sequential methods, by analyzing results in stages and determining the amount of additional testing based on a partial sample can reduce costs without sacrificing needed confidence in results.
3. The building codes can be assured that the test data they receive as the basis for design values is associated with a uniform level of certainty.

The second area which a standard procedure perhaps should address, is the matter of sub-populations within the overall population. When a specific product is very homogeneous, this is not a problem. However, in the U.S., PS-1 plywood may be manufactured from a variety of species using different layups. The result is that the overall property distribution is really made up of a number of smaller populations added together according to their production volume. Normally they originate from a particular producer using a given species and layup combination or a number of producers using similar species and layups. These subpopulations do not get mixed together in shipment. They are likely to arrive at the jobsite or other point of use as a separate sub-population. It would seem desirable to limit the characteristic values of the sub-population as well, although perhaps not as severely.

ASTM Standard D2555 which deals with species grouping, addresses the problem relative to sub-populations within species by specifying that the 5% characteristic level for a group of species could not exceed an approximate 12% exclusion level for a sub-population of a species or the 7% level for an individual species. Other numbers could be used; these are simply examples of how a similar problem was handled in the past.

Some general notes and comments on setting up a sampling scheme may be useful. Unless a very intensive and perhaps ongoing testing program is justified by the intended use of the product, testing to evaluate engineering properties is likely to be done rather infrequently and with limited resources. Under these conditions confidence in the characteristic values obtained from the testing program can be improved by selecting the test material to be near-minimum strength where possible.

For example, when sampling from plywood panels:

1. Bending tests on plywood can be conducted on a full panel or the areas most severely affected by knots, knotholes and distorted grain may be placed in the zone of maximum stress.
2. Plywood shear through-the-thickness specimens can be selected to include the most severe core-gap and core joint combination.
3. Rolling shear specimens may be oriented to shear "checks open", and constructions may be selected to have the thickest veneers or parallel laminated veneers.

Weak areas of reconstituted panels cannot be so easily selected by visual examination. However, quality control procedures used by the manufacturers of these products often include other measures of strength or of variables related to strength. This information can help in the selection of near minimum material.

Even when sampling and testing is quite intensive, steps should be taken to make certain that near minimum material is included in a representative manner.

When there is no way of picking near minimum material, random selection is the only approach open. While low strength material can be selected within a plywood panel, it is often very difficult to pick out the lowest strength panels from a group of panels. In this case, random procedures should be used. Likewise there is often no means of selecting minimum producers from a group of producing mills. Therefore, it is wise to include all manufacturers if at all possible.

When sampling plywood from a specific manufacturer, it is best to spread the sampling, however lightly, over a long period of time. This is because changes in the manufacturing process, or in the character of the raw material supplying the mill, are apt to occur rather infrequently. Sampling for a specific test should be spread out over as many panels of the sample as possible, rather than most specimens for a property from a single panel. This is because the panels within a sample from a given mill can vary substantially.

In summary, a sampling and analysis standard might be most useful if it specified rather specifically the statistical lower confidence level for key characteristic levels of the property distribution curve, such as the 5% for strength or the 30% or mean for stiffness. It could also be specific in limiting the relationship of sub-populations to these key exclusion levels.

The confidence level selected should be reasonably consistent with levels which have been acceptable in the past on a less formal basis. Thus, if in the past the 5% exclusion level of a small sample has been accepted as applying to the population, then it would be consistent to require only a 50% confidence level for determination of 5% exclusion levels. The confidence level required can have a large impact on the amount of sampling and testing required to substantiate a given exclusion level. One cannot expect to radically change these requirements simply by putting them in a standard.

Other aspects of good sampling practice as detailed above might best be set forth as guidelines or principles to be applied using good judgement to specific needs.

NOTES AND PAPERS
OF THE RILEM-MEETING

LILLEHAMMER
NORWAY
MAY 1983

NOTES AND PAPERS
OF THE RILEM-MEETING

LILLEHAMMER
NORWAY
MAY 1983

Meeting No 9, Lillehammer, Norway, May 1983

The chairman, Professor Kuipers, opened the meeting and outlined the programme of working for the group. Because of the large number of delegates present and the limited time available he suggested that three sub-groups should be formed to deal separately with plywood, joints and structures. This proposal was accepted.

1) 3-TT Testing methods for mechanical fasteners.

The tentative recommendations for the testing of nails, TT-1B, were discussed. Dr. Korin told the sub-group that he had carried out some tests in accordance with the standard and these were also discussed.

The following amendments were agreed:

- 1 clause B.2.2(c): delete "wood and wood-based sheet materials"
- 2 clause B.4.1 : replace "1 mm" by "2 mm"
- 3 clause B.7.3.1 : amend to read "... rate of deformation of 2.5 ± 0.5 mm/min ..."

A draft standard for the testing of staples, prepared by Professor Kuipers, was considered in detail. As a result of the discussions Mr Tory is to prepare a second draft for comment for inclusion in the proceedings of the CIB-W18 meeting.

2) 57-TSB Testing methods for timber structures.

A first draft had been prepared by Mr. Tory and several comments had been received. The first draft and the comments were discussed in detail. Mr. Tory will prepare a second draft based on the results of the discussion. This second draft will be sent out for comment in due time before the next meeting.

The following general decisions were taken:

- This standard will not cover on-site testing of completed structures
- The second draft of this standard will not cover structures made partly or wholly from reconstituted wood. It is intended to incorporate such structures at a later stage by means of appropriate amendments.
- The second draft of this standard will not contain a chapter on acceptance.
- It was felt that guidelines for the interpretation of the test results should be worked out. Whether these guidelines shall be included in this standard or published elsewhere will be decided after their elaboration.

3) 57 TSB Testing methods for board materials.

Papers discussed: RILEM Recommendation TT2 "Testing methods for plywood in Structural Grades for use in load-bearing structures" 1981
POST P.W. "Effect of test piece size on panel bending properties"
RILEM/CIBW15 Lillehammer June 1983
LEE, I. "Tentative proposals for testing particleboard for use in load bearing structures" RILEM/CIBW18 Helsinki 1980.

It was agreed that RILEM/TT2 - 1981 Recommendation could be usefully redrafted or extended to relate to particleboard (including wood chipboard), waferboard, flakeboard and O.S.B. (but not composite boards or fibre building boards at this stage).

Section 1 - Physical Properties requires little alteration except that the procedure for sampling should await ISO recommendations.

Section 2 - Mechanical Properties for strength and stiffness in bending, compression and tension require only minor alteration. There was some feeling that cyclic conditioning should precede testing and that some means of relating these tests to routine quality controls should be sought.

In trying to adapt the panel sheet test for particleboard, APA reported some difficulty in getting the rails to develop the full shear load into the specimen. It was agreed that the shear modulus could be found from deformation measurements along a diagonal of the panel shear strength test-piece (in accordance with A.S.T.M. procedure). Consequently, the separate test for panel shear stress described in TT2 was thought to be unnecessary. It was suggested that the tests described in TT2 should be extended to cover 'impact' and 'creep'.

As a long-term aim it should be possible to establish non-destructive testing for particleboards. Meanwhile, it was agreed to adapt the TT2 plywood tests to suit particleboard material. Mr. Lee offered to draft the tests for bending compression and tension, and the APA representatives agreed to draft suitable tests for shear strength and shear modulus.

RECOMMENDATION TENTATIVE 3TT-1; C

D R A F T

TENTATIVE RECOMMENDATION 3TT-1; C

3TT-1; C

JOINT COMMITTEE RILEM/CIB-3TT: TESTING METHODS FOR TIMBER

Testing methods for joints with mechanical fasteners in load-bearing timber structures.

Annex C: "Staples".

The text presented here is a draft on which views and technical comments are invited. A final recommendation taking account of comments will be produced by RILEM committee 3TT. Comments to be sent to: Prof. ir. J. Kuipers, Stevin Laboratorium, Stevinweg 4, 2628 CN Delft, The Netherlands; before

FOREWORD

Final Recommendations 3TT-1: "Testing methods for joints with mechanical fasteners in load-bearing timber structures" were published in Vol. 12 No. 70 1979 of this journal. It was foreseen that Annexes should be produced for testing methods for joints with specific fasteners. A first Annex 3TT-1; A Punched Metal Plates was published as a tentative recommendation in 1978, finalized in 1981 and published in Materials and Structures Vol. 15 No. 88 1982. The second Annex 3TT-1; B about testing methods for nails will be published as a Tentative Recommendation in 1983.

This is the third Annex 3TT-1; C about testing methods for staples.

C.0. INTRODUCTION

This annex was produced in order to encourage the use of standard test methods for determining the strength properties of joints with different types of staples, used in load-bearing timber structures. ¹⁾

C.1. DEFINITIONS

Staple : double-bent, U-shaped piece of round, square, oval or rectangular wire with pointed legs.

Staple-back : connection between the two staple-legs.

Back-centre : centre of staple-back.

N.B. All end and edge distances as well as mutual distances

between staples are measured from back-centres.

Staple-length : length of each staple-leg, including point.

Staple-width : distance between staple-legs.

Staple-diameter : smallest dimension of each staple-leg

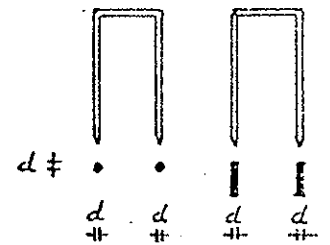
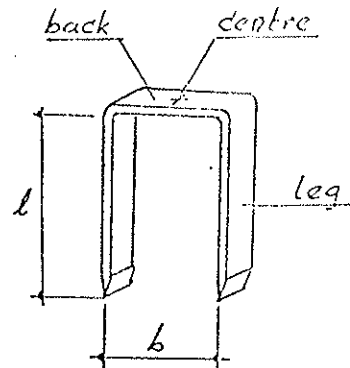

Back-angle γ : smallest angle between back-direction and grain-direction.

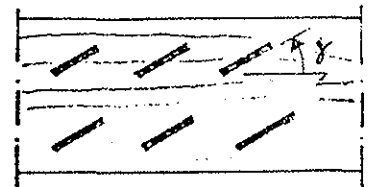

¹⁾ Standard rules for the determination of characteristic strength and deformation values will be developed by CIB-W18.

C.2. SCOPE

C.2.1. These Recommendations are an Annex to the Recommendations 3TT-1: "Testing methods for joints with mechanical fasteners in load-bearing timber structures".

C.2.2. This annex gives preferred test methods for determining

- a) load-slip characteristics and maximum load of laterally loaded stapled joints; both for wood-to-wood joints and for wood-based sheet materials to wood and vice versa.
Various angles between the applied force and the direction of the grain of the timber (load-grain angle β) are possible;
- b) load-slip characteristics and maximum load for axially loaded stapled joints (withdrawal testing);
- c) mechanical properties of staples, timber and wood-based sheet materials.

C.3. FIELD OF APPLICATION

These recommended test procedures apply to joints with all types of staples. ¹⁾

C.4. MANUFACTURING AND CONDITIONING OF TEST SPECIMENS

C.4.1. Manufacturing.

Test specimens shall be made in the same way as in practice.
The staple-backs should protrude above the surface.

¹⁾ For the intended use in load-bearing structures the user shall pay much attention to guaranteed materials and quality control of the staples.

C.4.2. Conditioning of test specimens.

The test specimens shall be manufactured with the timber and wood-based materials at an equilibrium moisture content corresponding to $20 \pm 2^{\circ}\text{C}$ and 0.8 ± 0.05 relative humidity. Testing shall be carried out at either ^{1) 2)}

- a) $20 \pm 2^{\circ}\text{C}$, 0.8 ± 0.05 rh;
- b) after further conditioning for at least one week at $20 \pm 2^{\circ}\text{C}$, 0.65 ± 0.05 rh;
- c) other specified conditions.

The condition used shall be stated in the test report.

C.5. SAMPLING

C.5.1. The materials from which the test specimens will be made must be sampled in accordance with ISO 0000. ³⁾

C.5.2. For determination of load-slip characteristics and maximum loads, species and quality of the materials shall be as specified for the test.

C.6. TESTING JOINTS WITH LATERALLY LOADED STAPLES

C.6.1. TEST SPECIMENS

C.6.1.1. Wood to wood joints

C.6.1.1.1. To measure joint strength parallel to the grain test specimens shall be made either as

- a) 3-member joints according to Fig. 1 for single shear action of the staples;
- b) symmetrical 4-member double joint specimens according to Fig. 2 for single shear action of the staples.

- 1) The climate conditions for testing defined in this clause differ from, and supersede, those recommended in Annex A Punched Metal Plate Fasteners.
- 2) Attention is drawn to the content of International Standard ISO 554 'Standard Atmospheres for Conditioning and/or Testing - Specifications' and the moisture classes defined in CIB Structural Timber Design Code (fifth edition 1980).
- 3) To be prepared by CIB-W18.

- C.6.1.1.2. The penetration length into the central member shall be chosen so that the yieldpoint of the leg will be reached at or before the max. load occurs.

N.B. This penetration length can be estimated as

$$l_h = 1.4d \sqrt{\frac{\sigma_v}{\sigma_s}} \approx 1,1$$

where

σ_y = yieldstrength of the staple material

and

σ_s = embedding strength of the wood.

- C.6.1.1.3. The thickness t_c of the central member must be chosen such that:

$$t_c \geq (8d + 3d) = 11d$$

(Fig. 1)

- C.6.1.1.4. The thickness t_s of the side members, the mutual staple distances $s_{//}$ and s_{\perp} as well as the end and edge distances shall be chosen so, that the embedding strength of the timber rather than e.g. its shear strength determines the maximum load.
- C.6.1.1.5. The number of staples in each contact surface between the members and placed in a row parallel to the force-direction shall be 2.
- C.6.1.1.6. Tests shall be done with equal numbers of joints with back-angles of $\gamma = 0^\circ$, $\gamma = 45^\circ$ and $\gamma = 90^\circ$ respectively.

C.6.1.1.7. For determination of the joint strength parallel to the grain tension tests should normally be used. If a 4 member test specimen similar to Fig. 2 is used, attention should be given to the fact that the strength of the weakest of two joints is found. This will influence the statistical interpretation of the test results.

If a specimen according to Fig. 1 is used the separation of the side members, in combination with pulling out of the staples, should not be hindered by the loading-equipment.

Compression test specimens may be used provided buckling is avoided.

C.6.1.1.8. For measuring the strength perpendicular to the grain, test specimens according to Fig. 3 shall be used. Member thicknesses shall be in accordance with C.6.1.1.3. Loading may be tensile or compressive (compare Fig. 3 and 4 for example).

C.6.1.2. Sheetmaterial-to-wood-joints

C.6.1.2.1. Test specimens shall be made as symmetrical 3-member joints fastened with eight staples (Fig. 5).

If the sheetmaterial has directional properties tests should also be carried out to enable assessment of the effect of board orientation.

C.6.1.2.2. The penetration length of the staples into the central member shall be chosen so that the yield-point of the leg will be reached at or before the max. load occurs.

N.B. See C.6.1.1.2.

C.6.1.2.3. The thickness t_c of the central member shall be $8d + 3d = 11d$ (Fig.1).

C.6.1.2.4. The thickness t_s of the side members is equal to the production thickness of the sheetmaterial.

C.6.1.2.5. The number of staples in each contact surface between the members and placed in a row parallel to the force direction shall be 2.

C.6.1.2.6. See C.6.1.1.6. ... C.6.1.1.8.

C.6.2. NUMBER OF TESTS

C.6.2.1. Sufficient specimens should be tested to permit a statistical interpretation of the results.

C.6.2.2. If strength values for a series of staples with different diameters must be determined it is sufficient to test a relevant number of diameters so that interpolation of the results can take place.

C.6.3. LOADING PROCEDURE

C.6.3.1. The load shall be applied and deformations recorded in 3TT-1: clause 7.

C.6.3.2. The deformation of the joint is defined as the mean value of the mutual displacements of the two side members with respect to the central member.

C.6.4. RESULTS

The deformation and the maximum loads for each test as well as all other relevant information shall be recorded as recommendation in 3TT-1: clause 7.

C.7. TESTING OF AXIAL LOADED STAPLES I.E. WITHDRAWAL
STRENGTH AND PULL-THROUGH STRENGTH

C.7.1. Test Specimens.

C.7.1.1. Withdrawal strength.

C.7.1.1.1. The timber member shall be cut and planed such
that one face is tangential to the growth rings.

C.7.1.1.2. Test specimens shall be in accordance with Fig. 6.

C.7.1.2. Pull-through strength.

C.7.1.2.1. Test specimens shall be in accordance with Fig. 7
and supported during testing as shown in Fig. 8.

C.7.2. Number of tests.

See C.6.2.

C.7.3. Loading procedure.

C.7.3.1. The load shall be applied at a constant rate of
 2.5 ± 0.625 mm/min for a withdrawal of at least 10 mm.
Load/slip curves shall also be recorded.

C.7.4. Results.

See C.6.4.

C.8. MATERIAL PROPERTIES

C.8.1. Bending properties of staples.

The bending strength of the staple shall be determined by
a bending test according to Fig. 9. The bending strength
shall be calculated from the highest load achieved for
a deflection of $2d$.

(Staple test not possible? Alternative?)

Values for l , r and for the rate of deflection are given in the table below:

d (mm)	l (mm)	r (mm)	defl. mm/min.
2.0 - 3.0	25	6	3
3.1 - 4.4	38	6	5
4.5 - 6.0	50	12	6
6.1 - 8.0	75	12	8
8.1 - 10.0	90	20	10

C.8.2. The embedding strength of the timber and of the wood-based sheetmaterials must be determined following Fig. 10.

C.8.3. Test report.

The test report shall include all relevant information recommended in 3TT-1: clause 8.

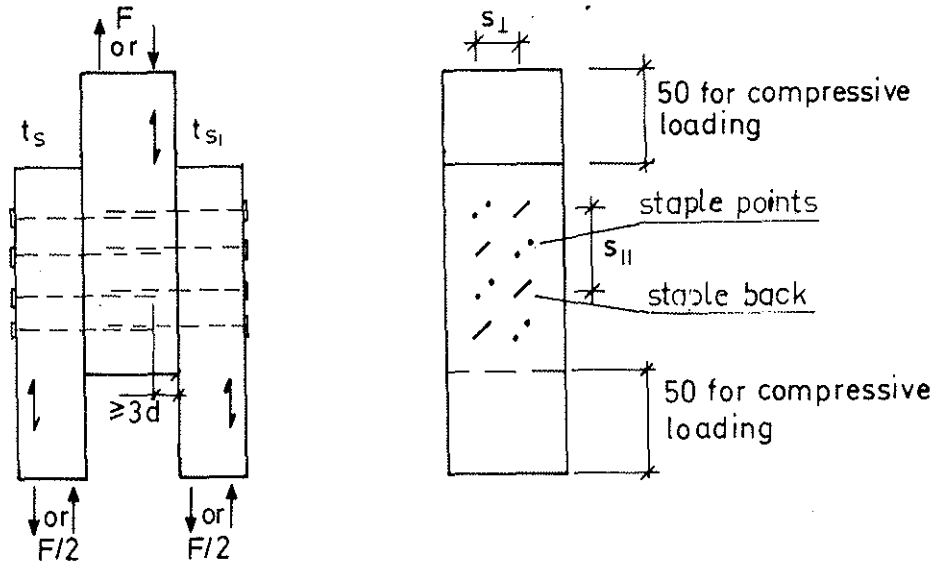

Fig. 1. Parallel to grain single shear specimen.

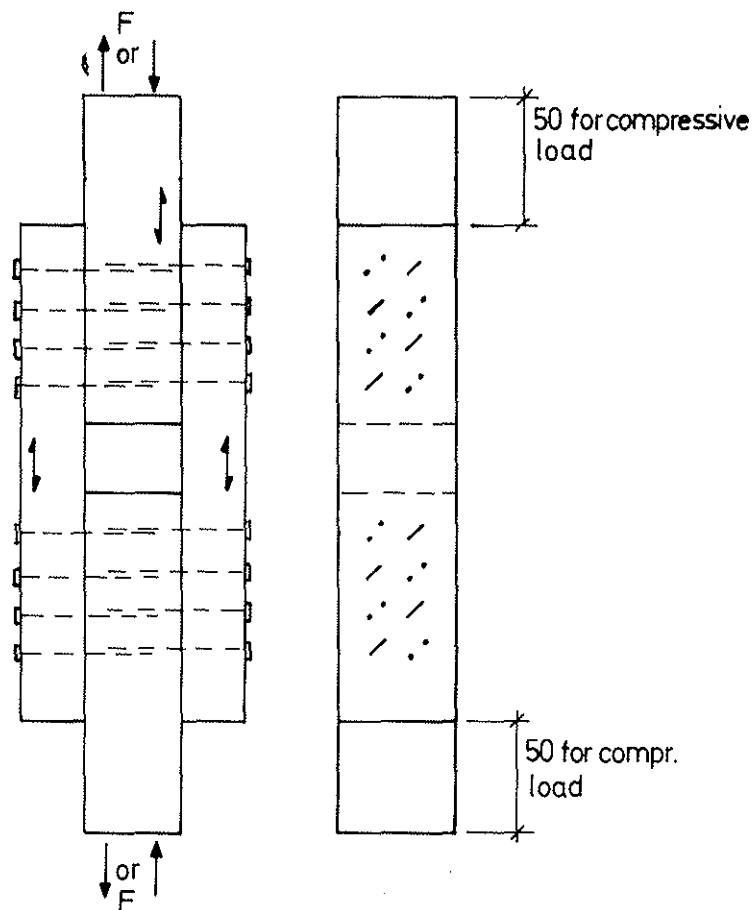

Fig. 2. Two - joint parallel to grain single shear specimen.

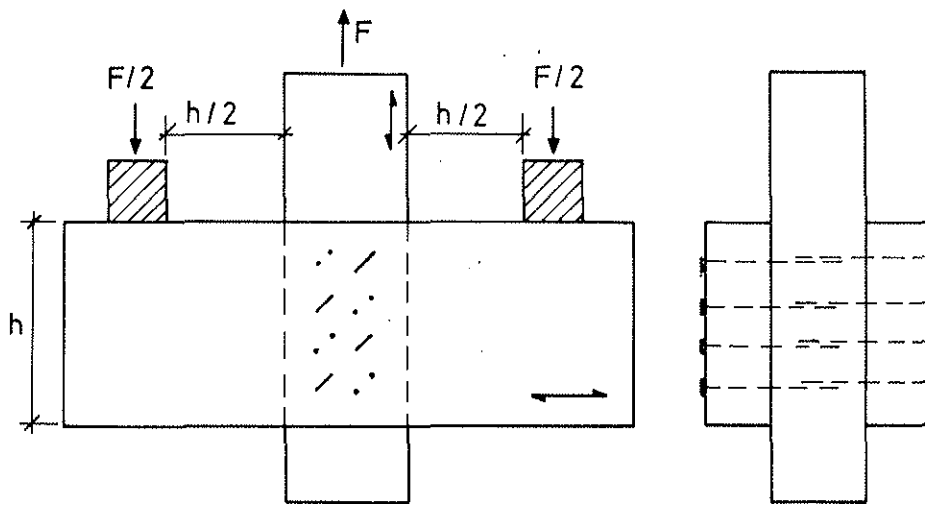

Fig. 3(a). Perpendicular to grain single shear specimen tensile loading.

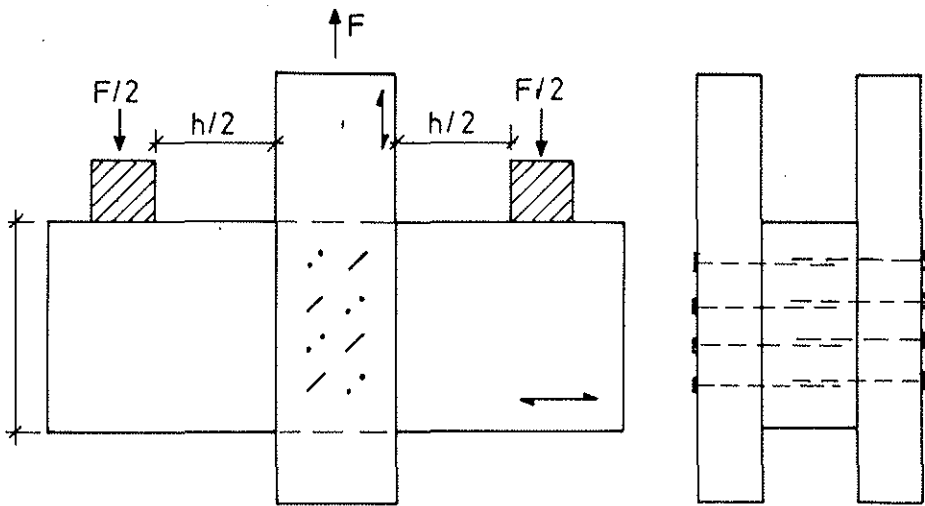

Fig. 3 (b). Perpendicular to grain single shear specimen tensile loading.

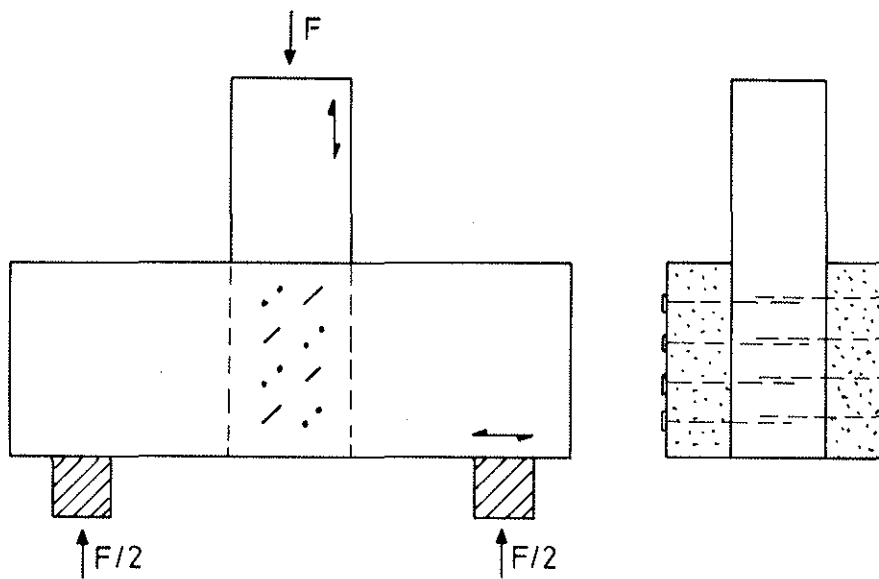

Fig.4 Perpendicular to grain single shear specimen compressive loading.

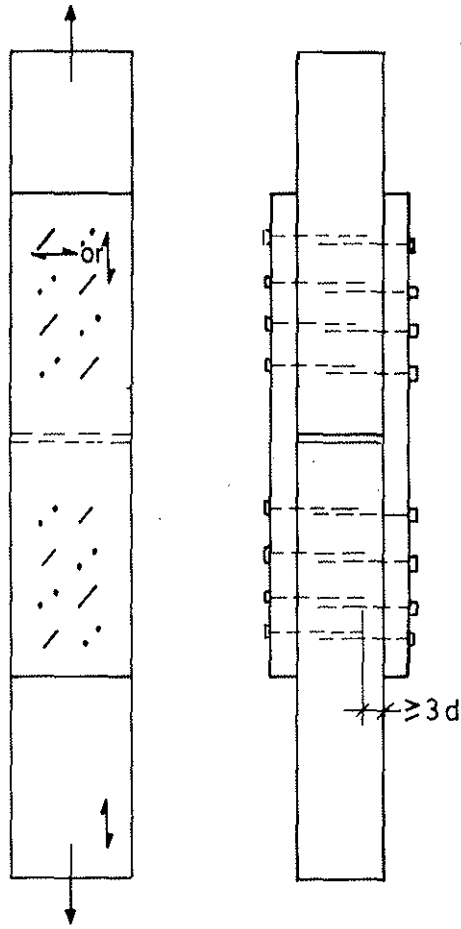

Fig. 5. Sheet material to wood single shear specimen.

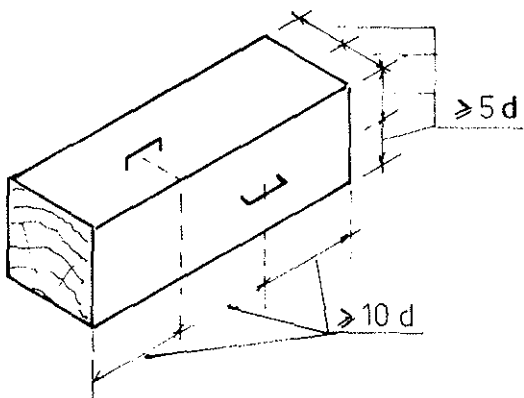

Fig 6 Withdrawal specimen

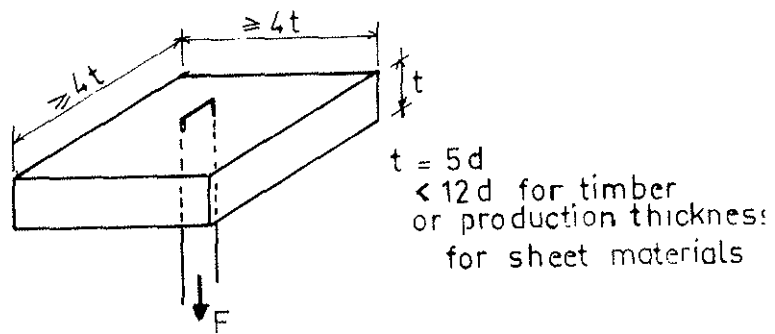
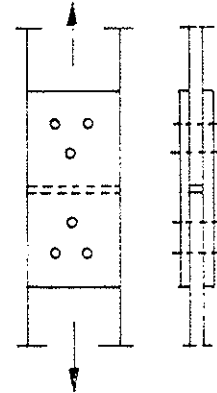

Fig 7 Pull-through specimen

Introduction

The report deals with the statistical treatment of test results of symmetrical specimens, one of which fails first. The result is twofold in such cases: one knows the failure strength of one specimen, and also that the other one is stronger.



Theoretical considerations

The probability that the strength \underline{x} of a joint is less than x be

$$P [\underline{x} < x] = P$$

The probability that \underline{x} is in the interval x to $(x + dx)$ be

$$dP = p dx$$

The probability that $\underline{x} \geq x$ is $1-P$, and the probability that the weakest of 2 elements has a strength value $\geq x$ is the same as the probability that both elements have strength values $\geq x$.

This probability therefore is $(1-P)^2$. (1)

The probability that the weakest of 2 elements is in the interval x to $(x + dx)$ is

$$\begin{aligned} f dx &= - d(1-P)^2 = (1-P)^2 - (1-P-dP)^2 \\ &= 2(1-P) p dx - (p dx)^2 \end{aligned} \quad (2a)$$

or, with an infiniti small interval

$$f = 2 p(1-P) \quad (2)$$

Suppose that the original distribution has a mean value \bar{x}_1 and standard deviation σ_1 . The mean value of the distribution of "the weakest of two" is

$$\bar{x}_2 = \int x f dx = \int 2 x p (1 - P) dx \quad (3)$$

with variance

$$\sigma_2^2 = \int x^2 f dx - \bar{x}_2^2 = \int 2 x^2 p (1 - P) dx - \bar{x}_2^2 \quad (4)$$

For symmetrical distributions (of the strength of the single elements) we write

$$P - \frac{1}{2} = Q$$

Where Q is an odd function of $(x - x_1)$.

In that case

$$\begin{aligned} \bar{x}_2 &= \int x p (1 - 2Q) dx \\ &= \bar{x}_1 - 2 \int x p Q dx \end{aligned} \quad (5)$$

and

$$\begin{aligned} \sigma_2^2 &= \int x^2 p (1 - 2Q) dx - \bar{x}_2^2 \\ &= \int (x - \bar{x}_1)^2 p (1 - 2Q) dx - (\bar{x}_1 - \bar{x}_2)^2 \end{aligned}$$

Because Q is an odd function of $(x - \bar{x}_1)$:

$$\int (x - \bar{x}_1)^2 p Q dx = 0, \text{ and therefore}$$

$$\sigma_2^2 = \int (x - \bar{x}_1)^2 p dx - (\bar{x}_1 - \bar{x}_2)^2 = \sigma_1^2 - (\bar{x}_1 - \bar{x}_2)^2, \quad (6)$$

so in this case only $\int x p Q dx$ needs to be determined.

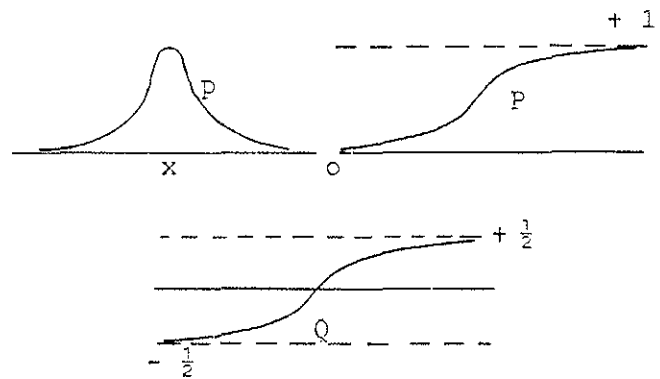

The graphical method

In the graphical method one makes use of probability paper where, -in the case of a normal distribution -the cumulative distribution curve appears as a straight line.

From the original P-distribution of the single specimen strength x , it is easy to find the distribution of the "weakest of two" by plotting values of $(1-P)^2$. This appears to be nearly a straight line, so it is approximately also a normal distribution, with the following values to be taken from the graph.

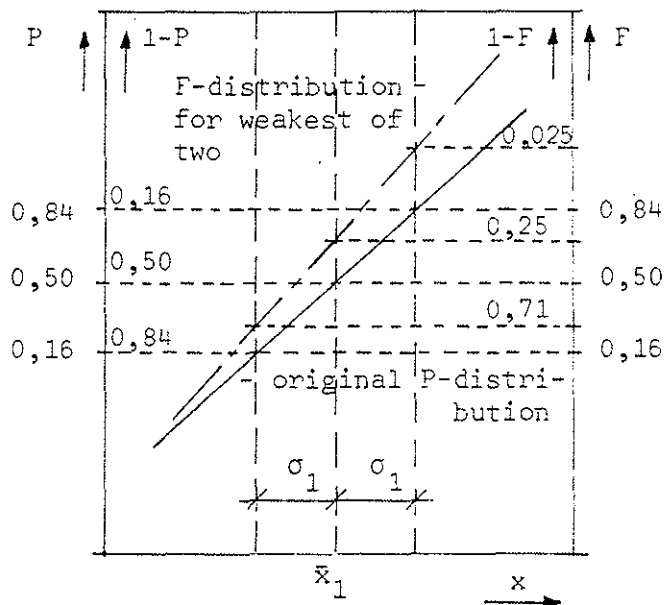

$$\bar{x}_2 = \bar{x}_1 - 0,55 \sigma_1 \text{ and } \sigma_2 = 0,82 \sigma_1$$

In evaluating test results one works in reverse, starting with values of \bar{x}_2 and σ_2 from which the values of the original distribution can be calculated as

$$\bar{x}_1 = \bar{x}_2 + 0,68 \sigma_2 \text{ and}$$

$$\sigma_1 = 1,21 \sigma_2$$

Approximate numerical method

Let the normal distribution be approximated by a binomial distribution with exponent $n = 10$ (for $n \rightarrow \infty$ the binomial distribution has the normal distribution as a limit; for $n = 10$ the approximation is rather good).

The calculation is given in the table, using formula 2^a (dx has a finite value).

x	- 5	- 4	- 3	- 2	- 1	0	1	2	3	4	5
P	1	10	45	120	210	252	210	120	45	10	1
1-P	1024	1023	1013	968	848	638	386	176	56	11	1
2p(1-P)	2048	20460	91170	232320	356160	321552	162120	42240	5040	220	2
p ²	1	100	2025	14400	44100	63504	44100	14400	2025	100	1
f	2047	20360	89145	217920	312060	258048	118020	27840	3015	120	1
fx	-10235	- 81440	-267435	-435840	-312060	0	118020	55680	9045	480	5
fx ²	51175	325760	802305	871680	312060	0	118020	111360	27135	1920	25

In this case

$$\bar{x}_1 = 0$$

$$\sigma_1^2 = \frac{\sum px^2}{\sum p} - \bar{x}_1^2 = \frac{2560}{1024} = 2,500; \quad \sigma_1 = 1,581$$

} original distribution

$$\bar{x}_2 = \frac{\sum fx}{\sum f} = \frac{-923780}{1048576} = - 0,881$$

$$\sigma_2^2 = \frac{\sum fx^2}{\sum f} - \bar{x}_2^2 = \frac{2621440}{1048576} - \bar{x}_2^2 = 1,724; \quad \sigma_2 = 1,313$$

} weakest of two distribution

Formula (6), used as a check, gives

$$\sigma_2^2 = 1,724 = \sigma_1^2 - (\bar{x}_1 - \bar{x}_2)^2 = 2,500 - 0,881^2$$

Here

$$\bar{x}_1 = \bar{x}_2 + \frac{0,881}{1,313} \sigma_2 = \bar{x}_2 + 0,671 \sigma_2$$

$$\sigma_1 = \frac{1,581}{1,313} \sigma_2 = 1,204 \sigma_2$$

Exact solution

Take a $N(0,1)$ - distribution, i.e. a normal distribution with mean value = 0 and standard deviation = 1, for which

$$p = \frac{1}{\sqrt{2\pi}} e^{-\frac{1}{2}x^2}$$

The value of the following integral is required:

$$U = \int_{-\infty}^{\infty} xp Q dx = 2 \int_0^{\infty} xp Q dx$$

$$\text{Let } Q = \int_0^x p dy = \frac{1}{\sqrt{2\pi}} \int_0^x e^{-\frac{1}{2}y^2} dy$$

$$\begin{aligned} \text{So } U &= \frac{1}{\pi} \int_0^{\infty} \int_0^x x e^{-\frac{1}{2}x^2 - \frac{1}{2}y^2} dx dy \\ &= \frac{1}{\pi} \int_0^{\infty} \int_0^{\pi/4} r^2 \cos \phi e^{-\frac{1}{2}r^2} dr d\phi \\ &= \frac{1}{\pi} \left\{ \int_0^{\infty} r^2 e^{-\frac{1}{2}r^2} dr \right\} \left\{ \int_0^{\pi/4} \cos \phi d\phi \right\} \end{aligned}$$

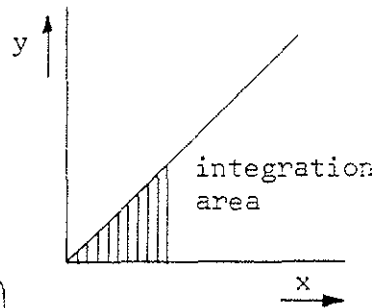

$$\text{Herein } \int_0^{\pi/4} \cos \phi d\phi = \frac{1}{2} \sqrt{2}$$

Further:

$$\int_0^{\infty} r^2 e^{-\frac{1}{2}r^2} dr = - \int_0^{\infty} r de^{-\frac{1}{2}r^2} = - \left[r e^{-\frac{1}{2}r^2} + \int_0^{\infty} e^{-\frac{1}{2}r^2} dr \right] =$$

$$= 0 + \frac{1}{2} \sqrt{2\pi} = \frac{1}{2} \sqrt{2\pi}$$

$$\text{So } U = \frac{1}{\pi} \frac{1}{2} \sqrt{2\pi} \cdot \frac{1}{2} \sqrt{2} = \frac{1}{2\sqrt{\pi}}$$

According to (5):

$$\bar{x}_2 = \bar{x}_1 - 2U = -\frac{1}{\sqrt{\pi}},$$

And according to 6):

$$\sigma_2^2 = 1 - \frac{1}{\pi}$$

The relationships become

$$\begin{aligned} \bar{x}_1 &= \bar{x}_2 + \sqrt{\frac{1}{\pi - 1}} \cdot \sigma_2 \\ &= \bar{x}_2 + 0,683 \sigma_2 \end{aligned}$$

and

$$\sigma_1 = \sqrt{\frac{\pi}{\pi - 1}} \cdot \sigma_2 = 1,211 \sigma_2$$

Further conclusions

If a structure consists of 3,4 ... n elements-in-series, so that the whole structure collapses if one element fails, similar calculations can be set up.

The first (graphical) method is easiest to use. The distribution for larger values of n however will become increasingly unsymmetrical, which means that the cumulative distribution function does not reach the values $1-P = 0,8413; 0,500; 0,1587$ at the abscissae $\bar{x} - \sigma; \bar{x}; \bar{x} + \sigma$ but at, say $x(-); x(0); x(+)$

Taking the known values of the latter abscissae as a starting point, one can calculate approximate values for the mean and standard deviation.

Suppose we have the unsymmetrical distribution

$$p = \frac{1}{\sqrt{2\pi}} (1 + ax) e^{-\frac{1}{2}x^2} \quad (a \text{ small})$$

Here $\bar{x} = a$

$$\sigma^2 = 1 - a^2$$

$$\begin{aligned} \text{and } x(-) &= -1 + a + \frac{1}{2} a^2 - \frac{3}{8} a^4 - \frac{1}{40} a^5 \\ x(0) &= a - \frac{1}{3} a^3 + \frac{4}{15} a^5 \\ x(+) &= 1 + a - \frac{1}{2} a^2 + \frac{3}{8} a^4 - \frac{1}{40} a^5 \end{aligned}$$

With good approximation

$$\bar{x} = \frac{1}{2} [x(+) + x(-)] \quad \text{and}$$

$$\sigma = \frac{1}{2} [x(+) - x(-)]$$

This has been determined for different values of n (for a N(0,1) distribution).

Formulas: $1 - P_n = (1 - P)^n$, from which $x(+)$ and $x(-)$ follow,

with these \bar{x}_n and σ_n are approximated.

$$\bar{x}_1 = \bar{x}_n + c_1 \sigma_n \quad \sigma_1 = c_2 \sigma_n$$

n	x(+)	x(-)	\bar{x}_n	σ_n	c ₁	c ₂
2	+0,2576	-1,3868	-0,5646	0,8222	0,687	1,216
3	-0,1039	-1,5897	-0,8468	0,7429	1,140	1,346
4	-0,3349	-1,7248	-1,0298	0,6950	1,482	1,439
5	-0,5014	-1,8250	-1,1632	0,6618	1,758	1,511
6	-0,6304	-1,9052	-1,2678	0,6374	1,989	1,569
7	-0,7347	-1,9704	-1,3526	0,6178	2,189	1,619
8	-0,8229	-2,0261	-1,4245	0,6016	2,368	1,662
9	-0,8965	-2,0745	-1,4855	0,5890	2,522	1,698
10	-0,9615	-2,1172	-1,5394	0,5778	2,664	1,731
100	-2,0913	-2,9243	-2,5078	0,4165	6,021	2,401
1000	-2,9042	-3,5786	-3,2414	0,3372	9,613	2,966
10000	-3,5619	-4,1412	-3,8516	0,2896	13,300	3,453

The values $n = 4$ and 8 occur in welding test specimens. The large values of n were included to show another aspect of testing of materials.

Suppose a certain material shows, when tested with specimens of certain dimensions, a mean strength of 60 N/mm^2 , normally distributed with standard deviation of 8 N/mm^2 . Now the dimensions are 10 times enlarged. When the aggregates are not changed (sand and gravel in concrete) and the material shows brittle behaviour in failure then the test specimen is equivalent to 1000 times the original one mounted in series. This means that one can then expect a mean strength of 34 N/mm^2 and a standard deviation of $2,7 \text{ N/mm}^2$.

Such phenomena with respect to the compression strength of concrete have been known since a long time but usually were attributed the influence of friction.

The explanation given in the foregoing seems more reasonable, the more so because in this way also the decreasing standard deviation can also be explained.

REPORT
AFRICAN, CARIBBEAN AND
LATIN-AMERICAN SUB-GROUP

by

R S Beckett
University of Zimbabwe
Zimbabwe

LILLEHAMMER
NORWAY
MAY/JUNE 1983

REPORT
AFRICAN, CARIBBEAN AND
LATIN-AMERICAN SUB-GROUP

by

R S Beckett
University of Zimbabwe
Zimbabwe

LILLEHAMMER
NORWAY
MAY/JUNE 1983

As joint co-ordinator of the Sub-Group for Africa, Caribbean and Latin American Region with Dr. Amintino De Freitas of Brazil I am pleased to report that there was a meeting of Third World countries in Melbourne, Australia between the 2nd to the 20th of May, sponsored by the UNIDO/CSIRO organisations. Fourteen countries attended the Workshop on Timber Engineering:

Brazil	Papua New Guinea
People's Republic of China	Peru
India	Sri Lanka
Indonesia	St. Lucia
Malasia	Thailand
Nepal	Tonga
Pakistan	Zimbabwe

The meeting considered aspects of timber engineering relevant to the application of structural timber in the Third World. Much of the Workshop was devoted to the valuable lessons to be learnt from the triumphs and tragedies experienced in developed countries. The Workshop was a great success and it is felt that the contacts made should not only prove invaluable but of lasting implication to the viability of timber technology in most countries.

The UNIDO organisation will shortly be publishing the various Workshop resolutions and it is interesting to note that these may well be a useful basis for collaboration between the CIB Sub-Group and the Pacific Area Standards Congress (PASC) which include such countries as Australia, New Zealand, Canada, the United States and Japan.