

INTERNATIONAL COUNCIL FOR BUILDING RESEARCH STUDIES AND DOCUMENTATION

WORKING COMMISSION W18 - TIMBER STRUCTURES

CIB - W18

MEETING FIFTEEN
KARLSRUHE
FEDERAL REPUBLIC OF GERMANY
JUNE 1982

INTERNATIONAL COUNCIL FOR BUILDING RESEARCH STUDIES AND DOCUMENTATION

WORKING COMMISSION W18 - TIMBER STRUCTURES

MEETING FIFTEEN
KARLSRUHE
FEDERAL REPUBLIC OF GERMANY
JUNE 1982

CONTENTS

	Page
1 List of Delegates	1
2 Chairman's Introduction	4
3 Co-operation with Other Organisations	4
4 Trussed Rafter Sub-Group	6
5 Plywood Sub-Group	6
6 Characteristic Stresses	6
7 Trussed Rafters	7
8 CIB Structural Timber Design Code	8
9 Timber-framed Housing Sub-Group	9
10 Other Business	9
11 Next Meeting	9
12 Papers Presented at the Meeting	10
13 Current List of CIB-W18 Papers	11

1. LIST OF DELEGATES

AUSTRIA

E Armbruster Glulam,Wien

BRAZIL

A R de Freitas Institute de Pesquisas, Sao Paulo

CANADA

T A Eldridge ISO-TC 165, Don Mills
R O Foschi Forintek Canada Corp., Vancouver B.C.
B Madsen University of British Colombia,
 Vancouver B.C.

DENMARK

A R Egerup Technical University of Denmark, Lyngby
M Johansen Danish Building Research Inst., Hørsholm
H Riberholt Technical University of Denmark, Lyngby

FEDERAL REPUBLIC OF GERMANY

P Beyersdorfer University of Karlsruhe, Karlsruhe
H Brüninghoff Glulam/CEI-Bois, Ulm
F Colling University of Karlsruhe, Karlsruhe
J Ehlbeck University of Karlsruhe, Karlsruhe
V Ellebracht Am. Plywood Association, Bad Soden
R Freiseis University of Karlsruhe, Karlsruhe
P Glos Technical University Munich, Munich
R Görlacher University of Karlsruhe, Karlsruhe
K Hemmer University of Karlsruhe, Karlsruhe
D Henrici University of Munich, Munich
H Kolb FMPA, Stuttgart
L Lükge COFI, Aachen
K Möhler University of Karlsruhe, Karlsruhe
P Müller University of Karlsruhe, Karlsruhe
W Siebert University of Karlsruhe, Karlsruhe
G Steck University of Karlsruhe, Karlsruhe
E Stengelin University of Karlsruhe, Karlsruhe
J Wenz University of Karlsruhe, Karlsruhe

FINLAND

E K Leppavuori	Technical Research Center of Finland, Espoo
E Pennala	Technical University Helsinki, Espoo
T Poutanen	Technical University Tampere, Tampere
U Saarelainen	Technical Research Center of Finland, Espoo

ISRAEL

U Korin	Building Research Station, Technion, Haifa
---------	--

NETHERLANDS

J Kuipers	Delft University of Technology, Delft
-----------	---------------------------------------

NORWAY

E Aasheim	Norsk Treteknisk Institutt, Oslo
-----------	----------------------------------

SOUTH AFRICA

F R P Pienaar	Nat. Timber Research Inst., Pretoria
---------------	--------------------------------------

SWEDEN

B Edlund	Chalmers Tekniska Högskola, Göteborg
U A Girhammar	FORTF-Research Department, Märsta
B Källsner	Swedish For. Prod. Res. Lab., Stockholm

SWITZERLAND

E Gehri	ETH Zürich, Zürich
U A Meierhofer	EMPA, Dübendorf

UNITED KINGDOM

H J Burgess	TRADA, High Wycombe
J G Sunley	TRADA, High Wycombe
J Tory	Princes Risborough Lab., Princes Risborough
R Verhorst	Am. Plywood Association, London

UNITED STATES OF AMERICA

B Baker

Am. Plywood Association, Tacoma

E G Stern

VPI and State University, Blacksburg

ZIMBABWE

R S Beckett

University of Zimbabwe, Salisbury

INTERNATIONAL STANDARDS ORGANISATION

A Sørensen

ISO-TC 165 Secretariat, Copenhagen

2. CHAIRMAN'S INTRODUCTION

MR. SUNLEY reminded the meeting of the changed secretariat of CIB-W18. Technical papers were now received and sent out by TRADA while the University of Karlsruhe undertook the preparation of proceedings and on this occasion also acted as host country.

He said the main objective of the group until now had been the preparation of the CIB Code. A reappraisal of the functions of CIB-W18 was now appropriate, but it was evident that support documents for the Code would be needed in addition to those already under development by RILEM as testing standards.

3. CO-OPERATION WITH OTHER ORGANISATIONS

ISO/TC 165: MRS. SORENSEN circulated paper CIB-W18/15-103-1 'Resolutions of TC 165 meeting in Athens 1981-10-12/13'. She reported that the draft standard on tests for timber in structural sizes had been sent out for comment. The USSR secretariat of TC 65 had been asked for information on the additional tests they had proposed, but no reply had been received.

A working group on species grouping had been set up with DR. LEICESTER as convenor. It was expected that a document would be produced for TC 165 in July 1982 and would then be sent out for comment.

MR. SUNLEY suggested it would be an advantage if the next CIB-W18 meeting could discuss the document in advance of the TC 165 meeting in about 18 months and it was agreed to include an appropriate item in the agenda.

PROFESSOR KUIPERS said he represented ISO TC 165 at the first meeting of a RILEM/TC 165 working group on plywood testing, held in Hamburg in October 1981. The RILEM document had been accepted in principle and it was expected that a further meeting would be arranged. He added that the final proposals for testing joints with punched metal plate fasteners were to be published in 'Materials and Structures' and in due time would be passed on to ISO.

Continuing her report, MRS. SORENSEN said a glulam production standard had been added to the programme of TC 165. MR. SUNLEY said this work had been discussed with CEI-Bois in Brussels after the Athens meeting of TC 165.

In connection with the TC 165 study of the CIB Code, MR. SUNLEY said this document would be regarded as presenting general principles and also as an operational document prescribing the manner in which design should be performed.

RILEM: PROFESSOR KUIPERS reported that his RILEM group had met that day. He said he would finalise the nails testing document in collaboration with MR. TORY for publication and eventual submission to TC 165. A further document on the testing of staples could have a similar basis.

The new RILEM group 57 TSB on test methods for structures and board materials had not been able to hold a discussion as two key members were unable to attend, but he hoped to make progress shortly.

CEI-Bois/FEMIB: MR. SUNLEY said a CIB-W18 objective was to co-operate with other bodies including the manufacturing industry. Discussions with CEI-Bois and FEMIB had agreed that they would take the lead in manufacturing standards while W18 would have the major role in design. A document on glulam manufacture had been produced and a small W18 group had provided comments.

IUFRO S5.02: PROFESSOR MADSEN reported on his timber engineering group's meeting in Boras, Sweden, 13-18 May 1982. The research programmes of the different countries had been studied, together with a number of special topics. Papers on load duration had developed two theoretical models for predicting time to failure. Other papers covered creep, and the effect of moisture content on tension, compression and bending strength. Stiffness models including allowance for variability were presented in papers on mechanical connections. There had been discussions of commercial proof grading, the consequences of stress grading and strength classifications and it was felt that more work was needed on these topics. Papers were included on failure in tension perpendicular to the grain and a yield function for generalised loading, also on the strength of glulam beams and members under combined bending and axial load.

The next meeting would be Xalapa in 1984, with an interim meeting at Madison in 1983 as part of the IUFRO Division 5 meeting. The topics to be considered would include reliability, bracing and electronic grading.

IABSE: PROFESSOR EDLUND reported as a representative of the International Association for Bridge and Structural Engineering, with some 2500 members from perhaps 45 to 50 countries. He said there was a working commission on steel and timber structures but little had been done on timber so far. IABSE members were interested in the CIB Code and a short note in their quarterly bulletin would mention the Code and state that information could be obtained from the CIB-W18 secretary.

4. TRUSSED RAFTER SUB-GROUP

DR. EGERUP described the background of the group, formed three years ago to produce a design section for the CIB Code. A parallel Nordic group had been active, producing relatively sophisticated work including a paper by MR. RIBERHOLT at the present meeting. A more simple approach was favoured by some other countries of his group, leading to span tables catering for the bulk of the designs required. He felt a special separate section of the CIB Code was desirable for trussed rafters.

After further discussion it was agreed that the working group's constitution, work and timescale would be reviewed after the presentation of relevant papers.

5. PLYWOOD SUB-GROUP

After a discussion of the difficulties of sampling and possibilities for further work it was agreed a new group should be formed with DR. GLOS as Chairman. Members from different countries were proposed, including members of the former group. It was agreed that the priority would be the sampling of wood-based materials in general and if DR. NOREN'S group wished to continue a linking of the two groups could take place later. The Chairman agreed to write to DR. NOREN explaining the situation.

6. CHARACTERISTIC STRESSES

Introducing paper CIB-W18/15-6-1 'Characteristic Stresses for the EEC Grades', MR. SUNLEY asked whether CIB-W18 could underwrite the values quoted. The discussion brought out the difficulty of agreeing precise values without detailed consideration of their derivation, and also the question of producing values in line with the strength classes in the CIB Code. It was finally agreed to incorporate wording emphasising that the

figures were only a guide with different samples leading to different results, and giving a range for each grade which might be 25-30 N/mm² for S10, 20-24 N/mm² for S8 and 15-18 N/mm² for S6. The Chairman said he would advise EEC of the group's decision.

7. TRUSSED RAFTERS

MR. PIENAAR presented his paper 15-14-2 'The Influence of Various Factors on the Accuracy of the Structural Analysis of Timber Roof Trusses'. Questions brought out the relationship of this work to previous South African studies establishing a realistic model as the basis for comparisons. DR. EGERUP suggested the second order effect covered in the paper would be of more importance in limit state design. Answering a question by MR. BECKETT the author said his paper did not go into the question of bracing.

MR. RIBERHOLT introduced paper CIB-W18/15-14-1 'Guidelines for Static Models of Trussed Rafters'. The subsequent discussion emphasised that the guidelines would lead to design data such as moment coefficients and span tables for incorporation in the Code. MR. RIBERHOLT raised the possibility of allowing for the low probability of the maximum permitted defect occurring in the most highly stressed areas.

MR. POUTANEN said the proposed alternative simple method would not be needed in Finland, where frame analysis was used; however information was needed on joint rigidity. MR. BURGESS said paper CIB-W18/14-14-1 'Wood Trussed Rafter Design' by Feldborg and Johansen indicated that the stiffnesses of fictive elements could be varied over a wide range without much change in the distribution of forces and moments.

MR. REECE's paper CIB-W18/15-14-4 'The Design of Continuous Members in Timber Trussed Rafters with Punched Metal Connector Plates' was introduced by MR. BURGESS. He said it applied the theory of elasticity to develop factors enabling a design procedure to fit the results of prototype tests. In the absence of the author no detailed questions were raised and further time would be required for proper study of the paper.

The paper CIB-W18/15-14-5 'A Rafter Design Method Matching UK Test Results for Trussed Rafters' was introduced by the author. Asked by PROFESSOR MADSEN about a possible size effect, MR. BURGESS said that Figure 2 showed a depth effect much more severe than traditionally applied for deep beams. DR. EGERUP and MR. RIBERHOLT agreed that there was a need to allow for this effect in design.

Another paper, CIB-W18/15-14-3 'Bracing Calculations for Trussed Rafter Roofs' was introduced by MR. BURGESS. DR. EGERUP suggested that optimal design of the roof as a whole would be achieved using thicker rafters, but MR. SUNLEY said this had been resisted by the manufacturing industry. MR. PIENAAR said South Africa also had bracing problems; the buckling tended to form an S shape in plan rather than a single arc across the roof, because of tile friction and because supports were commonly provided at the ridge as an erection aid.

MR. SUNLEY reverted to the general question of trussed rafter design, where the Nordic and CIB groups were working in parallel. DR. EGERUP said his group could take advantage of the Nordic work. He hoped they would extend it to a simple method with moment coefficients and his group could produce an Annex for the CIB Code. MR. SUNLEY and MR. RIBERHOLT pointed out the great advantage of having a single design method for all countries if this could be achieved.

8. CIB STRUCTURAL TIMBER DESIGN CODE

MR. SUNLEY said the views of CEI-Bois and FEMIB were being sought on the Code (5th Edition, August 1980). Some comments had been received and he hoped that further comments would lead to its adoption as the basis for a Eurocode. He asked CIB members to let him know of any proposed changes before a meeting of an editing sub-committee in early September 1982. The CIB were keen to see the final version published as a CIB document and he hoped it would go to press towards the end of the year. This programme was agreed by the members present.

9. TIMBER-FRAMED HOUSING SUB-GROUP

MR. SUNLEY said the request for formation of this sub-group on the structural design of timber-framed housing had come from CIB members. It was agreed that CIB-W18 should interest itself in the topic. A number of names were put forward as sub-group members and MR. SUNLEY mentioned a COFI representative as a possible Chairman.

10. OTHER BUSINESS

MR. BECKETT spoke of a need to extend CIB-W18 guidance to African, Central American and Caribbean countries. It was agreed that MR. BECKETT would do anything possible to further this aim and a suggestion of sometime holding a meeting in one of the areas would be borne in mind.

MR. SUNLEY proposed that the agenda for the next meeting should include timber grouping and it was agreed that the Secretary would write and ask MR. HOFMEYER to present this subject. Other subjects for the meeting would be the final CIB Code, trussed rafters (DR. EGERUP), truss plate design (MR. BOVIM), the testing of complete structures (PROFESSOR KUIPERS), the timber-framed housing sub-group and bracing (not restricted to trussed rafters).

MR. SUNLEY expressed the appreciation of CIB-W18 of the excellent arrangements made by PROFESSOR EHLBECK and his staff for the meeting and PROFESSOR MOHLER added his own appreciation.

11. NEXT MEETING

The next meeting of CIB-W18 will take place in Oslo, Norway in June 1983.

The meeting-after-next will probably be held in Switzerland in mid 1984.

The Chairmen of sub-groups are invited to progress the proceedings of their sub-groups well in advance of the main meetings.

12. PAPERS PRESENTED AT THE MEETING

- CIB-W18/15-6-1 Characteristic Strength Values for the ECE Standard for Timber - J G Sunley
- CIB-W18/15-7-1 Final Recommendation TT-1A: Testing Methods for Joints with Mechanical Fasteners in Load-Bearing Timber Structures. Annex A Punched Metal Plate Fasteners - Joint Committee RILEM/CIB-3TT
- CIB-W18/15-14-1 Guidelines for Static Models of Trussed Rafters - H Riberholt
- CIB-W18/15-14-2 The Influence of Various Factors on the Accuracy of the Structural Analysis of Timber Roof Trusses - F R P Pienaar
- CIB-W18/15-14-3 Bracing Calculations for Trussed Rafter Roofs - H J Burgess
- CIB-W18-15-14-4 The Design of Continuous Members in Timber Trussed Rafters with Punched Metal Connector Plates - P O Reece
- CIB-W18/15-14-5 A Rafter Design Method Matching U.K. Test Results for Trussed Rafters - H J Burgess
- CIB-W18/15-103-1 Resolutions of TC 165-meeting in Athens 1981-10-12/13
- CIB-W18/15-105-1 Terms of Reference for Timber-Framed Housing Sub-Group of CIB-W18

13. CURRENT LIST OF CIB-W18 PAPERS

Technical papers presented to CIB-W18 are identified by a code CIB-W18/a-b-c, where:

a denotes the meeting at which the paper was presented. Meetings are classified in chronological order:

- 1 Princes Risborough, England; March 1973
- 2 Copenhagen, Denmark; October 1973
- 3 Delft, Netherlands; June 1974
- 4 Paris, France; February 1975
- 5 Karlsruhe, Federal Republic of Germany; October 1975
- 6 Aalborg, Denmark; June 1976
- 7 Stockholm, Sweden; February/March 1977
- 8 Brussels, Belgium; October 1977
- 9 Perth, Scotland; June 1978
- 10 Vancouver, Canada; August 1978
- 11 Vienna, Austria; March 1979
- 12 Bordeaux, France; October 1979
- 13 Otaniemi, Finland; June 1980
- 14 Warsaw, Poland; May 1981
- 15 Karlsruhe, Federal Republic of Germany; June 1982

b denotes the subject:

- | | | | |
|----|------------------------------------|-----|--|
| 1 | Limit State Design | 100 | CIB Timber Code |
| 2 | Timber Columns | 101 | Loading Codes |
| 3 | Symbols | 102 | Structural Design Codes |
| 4 | Plywood | 103 | International Standards Organisation |
| 5 | Stress Grading | 104 | Joint Committee on Structural Safety |
| 6 | Stresses for Solid Timber | 105 | CIB Programme, Policy and Meetings |
| 7 | Timber Joints and Fasteners | 106 | International Union of Forestry Research Organisations |
| 8 | Load Sharing | | |
| 9 | Duration of Load | | |
| 10 | Timber Beams | | |
| 11 | Environmental Conditions | | |
| 12 | Laminated Members | | |
| 13 | Particle and Fibre Building Boards | | |
| 14 | Trussed Rafters | | |
| 15 | Structural Stability | | |
| 16 | Fire | | |
| 17 | Statistics and Data Analysis | | |

c is simply a number given to the papers in the order in which they appear:

Example: CIB-W18/4-102-5 refers to paper 5 on subject 102 presented at the fourth meeting of W18.

Listed below, by subjects, are all papers that have to date been presented to W18. When appropriate some papers are listed under more than one subject heading.

LIMIT STATE DESIGN

- 1-1-1 Limit State Design - H J Larsen
- 1-1-2 The Use of Partial Safety Factors in the New Norwegian Design Code for Timber Structures - O Brynildsen
- 1-1-3 Swedish Code Revision Concerning Timber Structures - B Norén
- 1-1-4 Working Stresses Report to British Standards Institution Committee BLCP/17/2
- 6-1-1 On the Application of the Uncertainty Theoretical Methods for the Definition of the Fundamental Concepts of Structural Safety - K Skov and O Ditlevsen
- 11-1-1 Safety Design of Timber Structures - H J Larsen

TIMBER COLUMNS

- 2-2-1 The Design of Solid Timber Columns - H J Larsen
- 3-2-1 The Design of Built-up Timber Columns - H J Larsen
- 4-2-1 Tests with Centrally Loaded Timber Columns - H J Larsen and S S Pedersen
- 4-2-2 Lateral-Torsional Buckling of Eccentrically Loaded Timber Columns - B Johansson
- 5-9-1 Strength of a Wood Column in Combined Compression and Bending with Respect to Creep - B Källsner and B Norén
- 5-100-1 Design of Solid Timber Columns (First Draft) - H J Larsen
- 6-100-1 Comments on Document 5-100-1, Design of Solid Timber Columns - H J Larsen and E Theilgaard
- 6-2-1 Lattice Columns - H J Larsen
- 6-2-2 A Mathematical Basis for Design Aids for Timber Columns - H J Burgess

- 6-2-3 Comparison of Larsen and Perry Formulas for Solid Timber Columns - H J Burgess
- 7-2-1 Lateral Bracing of Timber Struts - J A Simon
- 8-15-1 Laterally Loaded Timber Columns: Tests and Theory - H J Larsen

SYMBOLS

- 3-3-1 Symbols for Structural Timber Design - J Kuipers and B Norén
- 4-3-1 Symbols for Timber Structure Design - J Kuipers and B Norén
- 1 Symbols for Use in Structural Timber Design

PLYWOOD

- 2-4-1 The Presentation of Structural Design Data for Plywood - L G Booth
- 3-4-1 Standard Methods of Testing for the Determination of Mechanical Properties of Plywood - J Kuipers
- 3-4-2 Bending Strength and Stiffness of Multiple Species Plywood - C K A Stieda
- 4-4-4 Standard Methods of Testing for the Determination of Mechanical Properties of Plywood - Council of Forest Industries, B.C.
- 5-4-1 The Determination of Design Stresses for Plywood in the Revision of CP 112 - L G Booth
- 5-4-2 Veneer Plywood for Construction - Quality Specifications - ISO/TC 139. Plywood, Working Group 6
- 6-4-1 The Determination of the Mechanical Properties of Plywood Containing Defects - L G Booth
- 6-4-2 Comparison of the Size and Type of Specimen and Type of Test on Plywood Bending Strength and Stiffness - C R Wilson and P Eng
- 6-4-3 Buckling Strength of Plywood: Results of Tests and Recommendations for Calculations - J Kuipers and H Ploos van Amstel
- 7-4-1 Methods of Test for the Determination of Mechanical Properties of Plywood - L G Booth, J Kuipers, B Norén, C R Wilson

- 7-4-2 Comments Received on Paper 7-4-1
- 7-4-3 The Effect of Rate of Testing Speed on the Ultimate Tensile Stress of Plywood - C R Wilson and A V Parasin
- 7-4-4 Comparison of the Effect of Specimen Size on the Flexural Properties of Plywood Using the Pure Moment Test - C R Wilson and A V Parasin
- 8-4-1 Sampling Plywood and the Evaluation of Test Results - B Nor en
- 9-4-1 Shear and Torsional Rigidity of Plywood - H J Larsen
- 9-4-2 The Evaluation of Test Data on the Strength Properties of Plywood - L G Booth
- 9-4-3 The Sampling of Plywood and the Derivation of Strength Values (Second Draft) - B Nor en
- 9-4-4 On the Use of the CIB/RILEM Plywood Plate Twisting Test: a progress report - L G Booth
- 10-4-1 Buckling Strength of Plywood - J Dekker, J Kuipers and H Ploos van Amstel
- 11-4-1 Analysis of Plywood Stressed Skin Panels with Rigid or Semi-Rigid Connections - I Smith
- 11-4-2 A Comparison of Plywood Modulus of Rigidity Determined by the ASTM and RILEM CIB/3-TT Test Methods - C R Wilson and A V Parasin
- 11-4-3 Sampling of Plywood for Testing Strength - B Nor en
- 12-4-1 Procedures for Analysis of Plywood Test Data and Determination of Characteristic Values Suitable for Code Presentation - C R Wilson
- 14-4-1 An Introduction to Performance Standards for Wood-base Panel Products - D H Brown
- 14-4-2 Proposal for Presenting Data on the Properties of Structural Panels - T Schmidt

STRESS GRADING

- 1-5-1 Quality Specifications for Sawn Timber and Precision Timber - Norwegian Standard NS 3080
- 1-5-2 Specification for Timber Grades for Structural Use - British Standard BS 4978
- 4-5-1 Draft Proposal for an International Standard for Stress Grading Coniferous Sawn Softwood - ECE Timber Committee

STRESSES FOR SOLID TIMBER

- 4-6-1 Derivation of Grade Stresses for Timber in the UK - W T Curry
- 5-6-1 Standard Methods of Test for Determining some Physical and Mechanical Properties of Timber in Structural Sizes - W T Curry
- 5-6-2 The Description of Timber Strength Data - J R Tory
- 5-6-3 Stresses for EC1 and EC2 Stress Grades - J R Tory
- 6-6-1 Standard Methods of Test for the Determination of some Physical and Mechanical Properties of Timber in Structural Sizes (third draft) - W T Curry
- 7-6-1 Strength and Long-term Behaviour of Lumber and Glued Laminated Timber under Torsion Loads - K Möhler
- 9-6-1 Classification of Structural Timber - H J Larsen
- 9-6-2 Code Rules for Tension Perpendicular to Grain - H J Larsen
- 9-6-3 Tension at an Angle to the Grain - K Möhler
- 9-6-4 Consideration of Combined Stresses for Lumber and Glued Laminated Timber - K Möhler
- 11-6-1 Evaluation of Lumber Properties in the United States - W L Galligan and J H Haskell
- 11-6-2 Stresses Perpendicular to Grain - K Möhler
- 11-6-3 Consideration of Combined Stresses for Lumber and Glued Laminated Timber (addition to Paper CIB-W18/9-6-4) - K Möhler
- 12-6-1 Strength Classifications for Timber Engineering Codes - R H Leicester and W G Keating
- 12-6-2 Strength Classes for British Standard BS 5268 - J R Tory

- 13-6-1 Strength Classes for the CIB Code - J R Tory
- 13-6-2 Consideration of Size Effects and Longitudinal Shear Strength for Uncracked Beams - R O Foschi and J D Barrett
- 13-6-3 Consideration of Shear Strength on End-Cracked Beams - J D Barrett and R O Foschi
- 15-6-1 Characteristic Strength Values for the ECE Standard for Timber - J G Sunley

TIMBER JOINTS AND FASTENERS

- 1-7-1 Mechanical Fasteners and Fastenings in Timber Structures - E J Stern
- 4-7-1 Proposal for a Basic Test Method for the Evaluation of Structural Timber Joints with Mechanical Fasteners and Connectors - RILEM 3TT Committee
- 4-7-2 Test Methods for Wood Fasteners - K Möhler
- 5-7-1 Influence of Loading Procedure on Strength and Slip-Behaviour in Testing Timber Joints - K Möhler
- 5-7-2 Recommendations for Testing Methods for Joints with Mechanical Fasteners and Connectors in Load-Bearing Timber Structures - RILEM 3TT Committee
- 5-7-3 CIB-Recommendations for the Evaluation of Results of Tests on Joints with Mechanical Fasteners and Connectors used in Load-Bearing Timber Structures - J Kuipers
- 6-7-1 Recommendations for Testing Methods for Joints with Mechanical Fasteners and Connectors in Load-Bearing Timber Structures (seventh draft) - RILEM 3TT Committee
- 6-7-2 Proposal for Testing of Integral Nail Plates as Timber Joints - K Möhler
- 6-7-3 Rules for Evaluation of Values of Strength and Deformation from Test Results - Mechanical Timber Joints - M Johansen, J Kuipers, B Norén
- 6-7-4 Comments to Rules for Testing Timber Joints and Derivation of Characteristic Values for Rigidity and Strength - B Norén
- 7-7-1 Testing of Integral Nail Plates as Timber Joints - K Möhler

- 7-7-2 Long Duration Tests on Timber Joints - J Kuipers
- 7-7-3 Tests with Mechanically Jointed Beams with a Varying Spacing of Fasteners - K Möhler
- 7-100-1 CIB-Timber Code Chapter 5.3 Mechanical Fasteners; CIB Timber Standard 06 and 07 - H J Larsen
- 9-7-1 Design of Truss Plate Joints - F J Keenan
- 9-7-2 Staples - K Möhler
- 11-7-1 A Draft Proposal for an International Standard: ISO Document ISO/TC 165N 38E
- 12-7-1 Load-Carrying Capacity and Deformation Characteristics of Nailed Joints - J Ehlbeck
- 12-7-2 Design of Bolted Joints - H J Larsen
- 12-7-3 Design of Joints with Nail Plates - B Norén
- 13-7-1 Polish Standard BN-80/7159-04:Parts 00-01-02-03-04-05. "Structures from Wood and Wood-based Materials. Methods of Test and Strength Criteria for Joints with Mechanical Fasteners"
- 13-7-2 Investigation of the Effect of Number of Nails in a Joint on its Load Carrying Ability - W Nozynski
- 13-7-3 International Acceptance of Manufacture, Marking and Control of Finger-jointed Structural Timber - B Norén
- 13-7-4 Design of Joints with Nail Plates - Calculation of Slip - B Norén
- 13-7-5 Design of Joints with Nail Plates - The Heel Joint - B Källsner
- 13-7-6 Nail Deflection Data for Design - H J Burgess
- 13-7-7 Test on Bolted Joints - P Vermeyden
- 13-7-8 Comments to paper CIB-W18/12-7-3 "Design of Joints with Nail Plates" - B Norén
- 13-7-9 Strength of Finger Joints - H J Larsen
- 13-100-4 CIB Structural Timber Design Code. Proposal for Section 6.1.5 Nail Plates - N I Bovim

- 14-7-1 Design of Joints with Nail Plates (second edition)
- B Norén
- 14-7-2 Method of Testing Nails in Wood (second draft,
August 1980) - B Norén
- 14-7-3 Load-Slip Relationship of Nailed Joints -
-J Ehlbeck and H J Larsen
- 14-7-4 Wood Failure in Joints with Nail Plates - B Norén.
- 14-7-5 The Effect of Support Eccentricity on the Design
of W-and WW-Trusses with Nail Plate Connectors
- B Källsner
- 14-7-6 Derivation of the Allowable Load in Case of Nail
Plate Joints Perpendicular to Grain - K Möhler
- 14-7-7 Comments on CIB-W18/14-7-1 - T A Ç M van der Put
- 15-7-1 Final Recommendation TT-1A: Testing Methods for
Joints with Mechanical Fasteners in Load-Bearing
Timber Structures. Annex A Punched Metal Plate
Fasteners - Joint Committee RILEM/CIB-3TT.

LOAD SHARING

- 3-8-1 Load Sharing - An Investigation on the State of
Research and Development of Design Criteria -
E Levin
- 4-8-1 A Review of Load-Sharing in Theory and Practice
- E Levin
- 4-8-2 Load Sharing - B Norén

DURATION OF LOAD

- 3-9-1 Definitions of Long Term Loading for the Code of
Practice - B Norén
- 4-9-1 Long Term Loading of Trussed Rafters with Different
Connection Systems - T Feldborg and M Johansen
- 5-9-1 Strength of a Wood Column in Combined Compression
and Bending with Respect to Creep - B Källsner
and B Norén
- 6-9-1 Long Term Loading for the Code of Practice (Part 2)
- B Norén
- 6-9-2 Long Term Loading - K Möhler

- 6-9-3 Deflection of Trussed Rafters under Alternating Loading during a Year - T Feldborg and M Johansen
- 7-6-1 Strength and Long-Term Behaviour of Lumber and Glued-Laminated Timber under Torsion Loads - K Möhler
- 7-9-1 Code Rules Concerning Strength and Loading Time - H J Larsen and E Theilgaard

TIMBER BEAMS

- 4-10-1 The Design of Simple Beams - H J Burgess
- 4-10-2 Calculation of Timber Beams Subjected to Bending and Normal Force - H J Larsen
- 5-10-1 The Design of Timber Beams - H J Larsen
- 9-10-1 The Distribution of Shear Stresses in Timber Beams - F J Keenan
- 9-10-2 Beams Notched at the Ends - K Möhler
- 11-10-1 Tapered Timber Beams - H Riberholt
- 13-6-2 Consideration of Size Effects in Longitudinal Shear Strength for Uncracked Beams - R O Foschi and J D Barrett
- 13-6-3 Consideration of Shear Strength on End-Cracked Beams - J D Barrett and R O Foschi

ENVIRONMENTAL CONDITIONS

- 5-11-1 Climate Grading for the Code of Practice - B Norén
- 6-11-1 Climate Grading (2) - B Norén
- 9-11-1 Climate Classes for Timber Design - F J Keenan

LAMINATED MEMBERS

- 6-12-1 Directives for the Fabrication of Load-Bearing Structures of Glued Timber - A van der Velden and J Kuipers.
- 8-12-1 Testing of Big Glulam Timber Beams - H Kolb and P Frech
- 8-12-2 Instruction for the Reinforcement of Apertures in Glulam Beams - H Kolb and P Frech

- 8-12-3 Glulam Standard Part 1; Glued Timber Structures;
Requirements for Timber (Second Draft)
- 9-12-1 Experiments to Provide for Elevated Forces at the
Supports of Wooden Beams with Particular Regard
to Shearing Stresses and Long-term Loadings -
F Wassipaul and R Lackner
- 9-12-2 Two Laminated Timber Arch Railway Bridges Built
in Perth in 1849 - L G Booth
- 9-6-4 Consideration of Combined Stresses for Lumber and
Glued Laminated Timber - K Möhler
- 11-6-3 Consideration of Combined Stresses for Lumber and
Glued Laminated Timber (addition to Paper
CIB-W18/9-6-4)- K Möhler
- 12-12-1 Glulam Standard Part 2: Glued Timber Structures;
Rating (3rd draft)
- 12-12-2 Glulam Standard Part 3: Glued Timber Structures;
Performance (3rd draft)
- 13-12-1 Glulam Standard Part 3: Glued Timber Structures;
Performance (4th draft)
- 14-12-1 Proposals for CEI-Bois/CIB-W18 Glulam Standards -
H J Larsen
- 14-12-2 Guidelines for the Manufacturing of Glued Load-
Bearing Timber Structures - Stevin Laboratory
- 14-12-3 Double Tapered Curved Glulam Beams - H Riberholt
- 14-12-4 Comment on CIB-W18/14-12-3 - E Gehri

PARTICLE AND FIBRE BUILDING BOARDS

- 7-13-1 Fibre Building Boards for CIB Timber Code
(First Draft) - O Brynildsen
- 9-13-1 Determination of the Bearing Strength and the
Load-Deformation Characteristics of Particleboard
- K Möhler, T Budianto and J Ehlbeck
- 9-13-2 The Structural Use of Tempered Hardboard -
W W L Chan
- 11-13-1 Tests on Laminated Beams from Hardboard under
Short- and Longterm Load - W Nozynski
- 11-13-2 Determination of Deformation of Special Densified
Hardboard Under Long-term Load and Varying Temper-
ature and Humidity Conditions - W Halfar

- 11-13-3 Determination of Deformation of Hardboard under Long-term Load in Changing Climate - W Halfar
- 14-4-1 An Introduction to Performance Standards for Wood-Base Panel Products - D H Brown
- 14-4-2 Proposal for Presenting Data on the Properties of Structural Panels - T Schmidt

TRUSSED RAFTERS

- 4-9-1 Long-term Loading of Trussed Rafters with Different Connection Systems - T Feldborg and M Johansen
- 6-9-3 Deflection of Trussed Rafters under Alternating Loading During a Year - T Feldborg and M Johansen
- 7-2-1 Lateral Bracing of Timber Struts - J A Simon
- 9-14-1 Timber Trusses - Code Related Problems - T F Williams
- 9-7-1 Design of Truss Plate Joints - F J Keenan
- 10-14-1 Design of Roof Bracing - The State of the Art in South Africa - P A V Bryant and J A Simon
- 11-14-1 Design of Metal Plate Connected Wood Trusses - A R Egerup
- 12-14-1 A Simple Design Method for Standard Trusses - A R Egerup
- 13-14-1 Truss Design Method for CIB Timber Code - A R Egerup
- 13-14-2 Trussed Rafters, Static Models - H Riberholt
- 13-14-3 Comparison of 3 Truss Models Designed by Different Assumptions for Slip and E-Modulus - K Möhler
- 14-14-1 Wood Trussed Rafter Design - T Feldborg and M Johansen
- 14-14-2 Truss-Plate Modelling in the Analysis of Trusses - R O Foschi
- 14-14-3 Cantilevered Timber Trusses - A R Egerup
- 14-7-5 The Effect of Support Eccentricity on the Design of W- and WW- Trusses with Nail Plate Connectors - B Källsner
- 15-14-1 Guidelines for Static Models of Trussed Rafters - H Riberholt

- 15-14-2 The Influence of Various Factors on the Accuracy of the Structural Analysis of Timber Roof Trusses - F R P Pienaar
- 15-14-3 Bracing Calculations for Trussed Rafter Roofs - H J Burgess
- 15-14-4 The Design of Continuous Members in Timber Trussed Rafters with Punched Metal Connector Plates - P O Reece
- 15-14-5 A Rafter Design Method Matching U.K. Test Results for Trussed Rafters - H J Burgess

STRUCTURAL STABILITY

- 8-15-1 Laterally Loaded Timber Columns: Tests and Theory - H J Larsen
- 13-15-1 Timber and Wood-Based Products Structures. Panels for Roof Coverings. Methods of Testing and Strength Assessment Criteria. Polish Standard BN-78/7159-03

FIRE

- 12-16-1 British Standard BS 5268 the Structural Use of Timber: Part 4 Fire Resistance of Timber Structures
- 13-100-2 CIB Structural Timber Design Code. Chapter 9. Performance in Fire

STATISTICS AND DATA ANALYSIS

- 13-17-1 On Testing Whether a Prescribed Exclusion Limit is Attained - W G Warren

CIB TIMBER CODE

- 2-100-1 A Framework for the Production of an International Code of Practice for the Structural Use of Timber - W T Curry
- 5-100-1 Design of Solid Timber Columns (First Draft) - H J Larsen
- 5-100-2 A Draft Outline of a Code for Timber Structures - L G Booth
- 6-100-1 Comments on Document 5-100-1; Design of Solid Timber Columns - H J Larsen and E Theilgaard
- 6-100-2 CIB Timber Code: CIB Timber Standards - H J Larsen and E Theilgaard

- 7-100-1 CIB Timber Code Chapter 5.3 Mechanical Fasteners;
CIB Timber Standard 06 and 07 - H J Larsen
- 8-100-1 CIB Timber Code - List of Contents (Second Draft) -
H J Larsen
- 9-100-1 The CIB Timber Code (Second Draft)
- 11-100-1 CIB Structural Timber Design Code (Third Draft)
- 11-100-2 Comments Received on the CIB Code
 - a U Saarelainen
 - b Y M Ivanov
 - c R H Leicester
 - d W Nozynski
 - e W R A Meyer
 - f P Beckmann; R Marsh
 - g W R A Meyer
 - h W R A Meyer
- 11-100-3 CIB Structural Timber Design Code; Chapter 3 -
H J Larsen
- 12-100-1 Comment on the CIB Code - Sous-Commission Glulam
- 12-100-2 Comment on the CIB Code - R H Leicester
- 12-100-3 CIB Structural Timber Design Code (Fourth Draft)
- 13-100-1 Agreed Changes to CIB Structural Timber Design Code
- 13-100-2 CIB Structural Timber Design Code. Chapter 9:
Performance in Fire
- 13-100-3a Comments on CIB Structural Timber Design Code
- 13-100-3b Comments on CIB Structural Timber Design Code -
W R A Meyer
- 13-100-3c Comments on CIB Structural Timber Design Code -
British Standards Institution
- 13-100-4 CIB Structural Timber Design Code. Proposal for
Section 6.1.5 Nail Plates - N I Bovim
- 14-103-2 Comments on the CIB Structural Timber Design Code -
R H Leicester
- 15-103-1 Resolutions of TC 165-meeting in Athens 1981-10-12/13

LOADING CODES

- 4-101-1 Loading Regulations - Nordic Committee for Building Regulations
- 4-101-2 Comments on the Loading Regulations - Nordic Committee for Building Regulations

STRUCTURAL DESIGN CODES

- 1-102-1 Survey of Status of Building Codes, Specifications etc., in USA - E G Stern
- 1-102-2 Australian Codes for Use of Timber in Structures - R H Leicester
- 1-102-3 Contemporary Concepts for Structural Timber Codes - R H Leicester
- 1-102-4 Revision of CP 112 - First Draft, July 1972 - British Standards Institution
- 4-102-1 Comparison of Codes and Safety Requirements for Timber Structures in EEC Countries - Timber Research and Development Association
- 4-102-2 Nordic Proposals for Safety Code for Structures and Loading Code for Design of Structures - O A Brynildsen
- 4-102-3 Proposal for Safety Codes for Load-Carrying Structures - Nordic Committee for Building Regulations
- 4-102-4 Comments to Proposal for Safety Codes for Load-Carrying Structures - Nordic Committee for Building Regulations
- 4-102-5 Extract from Norwegian Standard NS 3470 "Timber Structures"
- 4-102-6 Draft for Revision of CP 112 "The Structural Use of Timber" - W T Curry
- 8-102-1 Polish Standard PN-73/B-03150: Timber Structures; Statistical Calculations and Designing.

- 8-102-2 The Russian Timber Code: Summary of Contents
- 9-102-1 Svensk Byggnorm 1975 (2nd Edition); Chapter 27:
Timber Construction
- 11-102-1 Eurocodes - H J Larsen
- 13-102-1 Program of Standardisation Work Involving Timber
Structures and Wood-Based Products in Poland

INTERNATIONAL STANDARDS ORGANISATION

- 3-103-1 Method for the Preparation of Standards Concerning
the Safety of Structures (ISO/DIS 3250) - Inter-
national Standards Organisation ISO/TC98
- 4-103-1 A Proposal for Undertaking the Preparation of an
International Standard on Timber Structures -
International Standards Organisation
- 5-103-1 Comments on the Report of the Consultation with
Member Bodies Concerning ISO/TS/P129 - Timber Struc-
tures - Dansk Ingeniorforening
- 7-103-1 ISO Technical Committees and Membership of ISO/TC 165
- 8-103-1 Draft Resolutions of ISO/TC 165
- 12-103-1 ISO/TC 165 Ottawa, September 1979
- 13-103-1 Report from ISO/TC 165 - A Sørensen
- 14-103-1 Comments on ISO/TC 165 N52 "Timber Structures;
Solid Timber in Structural Sizes; Determination of
Some Physical and Mechanical Properties"
- 14-103-2 Comments on the CIB Structural Timber Design Code -
R H Leicester

JOINT COMMITTEE ON STRUCTURAL SAFETY

- 3-104-1 International System on Unified Standard Codes
of Practice for Structures - Comité Européen
du Béton (CEB)
- 7-104-1 Volume 1: Common Unified Rules for Different Types
of Construction and Material - CEB

CIB PROGRAMME, POLICY AND MEETINGS

- 1-105-1 A Note on International Organisations Active
in the Field of Utilisation of Timber -
P Sonnemans
- 5-105-1 The Work and Objectives of CIB-W18 -
Timber Structures - J G Sunley
- 10-105-1 The Work of CIB-W18 Timber Structures -
J G Sunley
- 15-105-1 Terms of Reference for Timber -
Framed Housing Sub-Group of CIB-W18

INTERNATIONAL UNION OF FORESTRY RESEARCH ORGANISATIONS

- 7-106-1 Time and Moisture Effects - CIB W18/IUFRO 55.02-03
Working Party

INTERNATIONAL COUNCIL FOR BUILDING RESEARCH STUDIES AND DOCUMENTATION

WORKING COMMISSION W18 - TIMBER STRUCTURES

CHARACTERISTIC STRENGTH VALUES
FOR THE ECE STANDARD FOR TIMBER

by

J. G. Sunley

Timber Research and Development Association
United Kingdom

KARLSRUHE
FEDERAL REPUBLIC OF GERMANY
JUNE 1982

CHARACTERISTIC STRENGTH VALUES FOR THE ECE STANDARD FOR TIMBER

The Economic Commission for Europe (Timber Committee) has drafted a recommended Standard on stress grading of sawn timber. Delegates serving on the drafting committee have agreed the following Appendix to these rules:

It is necessary for structural use to lay down design stresses for each grade, and according to the various species. At present, however, different countries use different design methods and have different design stresses for similar grades of timber. In many cases countries arrive at similar design solutions, although they use different design stresses. This arises because of differences in loading conditions and methods of design, as well as methods of deriving design stresses.

In the interests of international trade, it is desirable to have one acceptable set of grading rules, even if countries ascribe different design stresses to them.

Until all countries agree on how design stresses should be derived from test data, it is not possible to arrive at the same design stresses from the same test data for all countries. It has to be accepted that at present different countries have different levels of safety and that it will be some years before these are the same in the various ECE countries. The CIB W.18 Commission is aiming towards harmonization of such methods but appreciates it will be some time before all countries can agree on the same safety levels.

However, by the use of factors dependent on national requirements for safety and loading, any national standard could derive design stresses from internationally agreed characteristic strength values. To determine these characteristic strength values it is first necessary to obtain agreement on sampling, testing, modification factors for size effects and data analysis. In the absence of an international standard on characteristic strength determination the following values are given as a guide only. The values were calculated using the three parameter Weibull distribution and represent lower 5% bending strengths for timber in the dry condition and at 200 mm depth. The values apply to European redwood (*Pinus sylvestris*) and whitewood (*Picea abies*), and to North American Douglas fir-larch, hem-fir and spruce-pine-fir. The values are 27.5 N/mm² for S10, 21.5 N/mm² for S8 and 15.5 N/mm² for S6.

The ECE has sought the agreement of CIB W.18 to the characteristic strength values given in this Appendix before they publish a final version of their rules.

The values given in the Appendix were based on the enclosed Report by A.R. Fewell of the Princes Risborough Laboratory, United Kingdom, and were recommended by a small working party.

The agreement of CIB W.18 members is sought for the values given.

J.G. SUNLEY,
Chairman.

UNITED NATIONS
ECONOMIC
AND
SOCIAL COUNCIL



RESTRICTED
TIM/WP.3/AC.3/10/Add.1
31 July 1981
Original : ENGLISH

ECONOMIC COMMISSION FOR EUROPE

Timber Committee

Ad hoc meeting on standardization of stress
grading and finger-jointing of coniferous
sawn timber

Geneva, 29 June - 1 July 1981

CHARACTERISTIC BENDING STRENGTH VALUES FOR THE REVISED
ECE STANDARD FOR STRESS GRADING OF CONIFEROUS SAWN TIMBER

Prepared by A.R. Fewell^{1/}

Transmitted by the Government of the United Kingdom

(Please find attached the research report prepared in response to the request of the ad hoc meeting on standardization of stress grading and finger-jointing of coniferous sawn timber. See TIM/WP.3/AC.3/10, para. 9).

^{1/} Princes Risborough Laboratory of the Building Research Establishment.

INTRODUCTION

The ECE recommended standard for stress grading coniferous sawn timber¹ was revised at an ad hoc meeting of the Timber Committee held in Geneva on 29 June to 1 July 1981. In the revised version the specifications for the S10 and S8 grades were altered taking account of the papers presented by Hoffmeyer², Fewell³ and Curry and Fewell⁴. The third grade, S6 was left unaltered pending the results of an analysis giving characteristic strength values and yields for a Canadian proposed specification. The meeting asked that the Princes Risborough Laboratory whilst analysing the Canadian S6 proposal should also produce results for the newly agreed S10 specification as additional information to that given by Hoffmeyer². This paper gives the results for the analysis of the S10 and S6 grades.

DATA

The data referred to in Table 1 and summarized here are the same as described more fully in Reference 4. All stress values were adjusted to 200 mm depth and are for the dry moisture condition.

Redwood/whitewood (Sweden). Five sizes containing different amounts of redwood and whitewood, selected unequally from parcels of commercial III, IV, V and VI grades. The parcels came from five different mills throughout Sweden.

Redwood/whitewood (Finland). Three sizes containing the same number of pieces of redwood and whitewood, selected about equally from parcels of commercial U/S, V and VI grades. The parcels came from four different mills in Finland.

Hem-fir (Canada). The sample of five sizes was collected from a number of mills in British Columbia to cover the range in quality produced for structural use. Each size contained about 40 per cent SEL, 20 per cent No 1 and 40 per cent No 2 of the NLGA joist and plank and structural light framing grades.

Spruce-pine-fir (Canada). The sample of two sizes was selected from three mills in British Columbia to cover the range in quality produced for structural use. It comprised a total of 7492 pieces equally divided between the two sizes but containing different amounts of SEL, No 1 and No 2 of the NLGA joist and plank and structural light framing grades.

Douglas fir (United Kingdom). This sample was obtained by random selection of an equal number of pieces of sawn timber in two sizes from the conversion of each log in a sample of eight logs from each of 21 plantation sites in the United Kingdom.

GRADE SPECIFICATIONS

(1) ECE recommended standard 1977.

S10 The margin knot area ratio (MKAR) and total knot area ratio (TKAR) must not be greater than $1/4$. Density must not be less than 450 Kg/m^3 for redwood and 420 Kg/m^3 for whitewood at 15 per cent moisture content.

S8 MKAR must not be greater than $1/2$. TKAR must not be greater than $1/4$.

S6 If MKAR is equal to or less than $1/2$ then TKAR must not exceed $1/2$. If MKAR is greater than $1/2$ then TKAR must not exceed $1/3$.

(2) Revised specifications agreed at June/July meeting.

S10 MKAR and TKAR must not be greater than $1/5$. No density limit.

S8 If MKAR is equal to or less than $1/2$ then the TKAR must not exceed $1/3$. If MKAR is more than $1/2$ then TKAR must not exceed $1/5$.

S6 Same as under (1) above.

(3) Canadian proposal for S6 grade.

S6 If MKAR is less than 1 then TKAR must not exceed $1/2$. If MKAR is equal to 1 then TKAR must not exceed $1/3$.

RESULTS AND CONCLUSIONS

The results of the analysis are given in Table 1. All characteristic strength values were calculated using the 3 parameter Weibull distribution.

The change to the S10 grade specification, which has the advantage of applicability to all species, causes a 3 per cent increase in strength when unsorted material is present and a 17 per cent loss in yield. Yields will depend upon the parcel of timber from which the graded pieces are selected and may be higher in practice since it is expected that S10 would be selected from mainly U/S quality material.

The S10 strength values for Canadian hem-fir and spruce-pine-fir are surprisingly low but this may be because the sample of timber from which the S10 was drawn contained a smaller amount of higher quality pieces than would be available by selection at the mill.

Changing the S8 grade specification reduces the strength by around 6 per cent but increases yields by around 20 per cent.

Grading out S10 material from S8 decreases the strength of S8 by an average of 4 per cent.

The Canadian proposal for S6 reduces the S6 grade strength by around 10 per cent and reduces rejects to approximately zero. For this reason the strength values for the proposed S6 grade cannot be considered realistic since the specification is too low for the selection from the range in quality of material in the available samples to truly reflect the composition of an S6 parcel from mill production.

REFERENCES

- 1 ECE recommended standard for stress grading coniferous sawn timber. Geneva. December 1977.
- 2 Hoffmeyer P. The effect of changing the ECE stress grading rules (with postscript) May 1981.*
- 3 Fewell A.R. The ECE S10 Timber stress grade. April 1981.*
- 4 Curry W.T. and Fewell A.R. Grade stress values for timber. April 1981. TIM/WP.3/AC.3/R.14/Add.1.*

* Papers presented at Geneva 29 June to 1 July.

Table 1

LOWER 5 PERCENTILE CHARACTERISTIC BENDING STRESSES (N/mm²) AND GRADE YIELDS

	Total N° of pieces	(1) 1977 rules					(2) Rules agreed July 1981					(3) Canadian proposal	
		S10	S8	S6	R	S8 (N°S10)	S10	S8	S6	R	S8 (N°S10)	S6	R
* Swedish & Finnish Redwood Whitewood	2350	28.9 41%	22.5 40%	16.8 15%	4%	24.5 82%	29.8 34%	21.5 57%	15.6 6%	4%	23.2 91%	13.6 9%	< 1%
≠ Swedish & Finnish Redwood Whitewood	652	27.5 23%	21.6 50%	16.8 23%	4%	22.6 73%	27.2 18%	20.4 69%	16.8 9%	4%	21.1 87%	15.0 12%	< 1%
Canadian Spruce-Pine-Fir	644	-	-	17.7 32%	8%	24.2 60%	24.7 24%	21.3 51%	17.3 18%	8%	22.2 74%	15.7 25%	1%
Canadian Hem-Fir	625	-	-	17.4 25%	2%	24.7 73%	25.9 44%	21.4 42%	16.3 11%	2%	23.0 86%	16.2 13%	0%
British Douglas Fir	379	-	-	15.7 39%	23%	19.9 38%	22.0 11%	19.7 45%	13.9 21%	23%	20.1 56%	14.8 39%	5%

* Contains U/S, V and VI Quality.

≠ Contains only V and VI in ratio 5:1.

INTERNATIONAL COUNCIL FOR BUILDING RESEARCH STUDIES AND DOCUMENTATION

WORKING COMMISSION W18 - TIMBER STRUCTURES

Final Recommendation TT-1A:
TESTING METHODS FOR JOINTS WITH MECHANICAL
FASTENERS IN LOAD-BEARING TIMBER STRUCTURES
ANNEX A
PUNCHED METAL PLATE FASTENERS
by
Joint Committee RILEM/CIB-3TT

KARLSRUHE
FEDERAL REPUBLIC OF GERMANY

JUNE 1982



Testing methods for joints with mechanical fasteners in load-bearing timber structures (*)

ANNEX A

Punched metal plate fasteners

FOREWORD

Final recommendations 3 TT-1: "Testing methods for joints with mechanical fasteners in load-bearing timber structures" were published in Vol. 12, No 70, 1979, of this journal. It was foreseen that Annexes should be produced for testing methods for joints with specific fasteners. A first Annex 3 TT-1A was published as a Tentative Recommendation for testing punched metal plate fasteners in Vol. 11, No 64, 1978, of this journal and submitted to ISO TC 165: Timber Structures. Comments have been received either directly or via the secretariat of ISO TC 165. Following consideration of these comments by the joint committee 3 TT of RILEM and CIB this final Recommendation was produced.

Méthodes d'essai pour assemblages avec systèmes d'attaches mécaniques dans des ossatures porteuses en bois

ANNEXE A

Assemblages par connecteurs métalliques à dents embouties (1)

PRÉFACE

Les recommandations finales TT-1 « Méthodes d'essai pour assemblages avec systèmes d'attaches mécaniques dans des ossatures porteuses en bois » ont été publiées au volume 12, n° 70, 1979, de cette revue. On y faisait mention de la rédaction d'annexes pour traiter des méthodes d'essais des assemblages spéciaux. Une première annexe TT-1 A a été publiée sous forme de recommandation provisoire pour les essais des assemblages par connecteurs métalliques au volume 11, n° 64, 1978, de cette revue et soumise à la Commission ISO TC 165 : structures en bois. Des commentaires ont été reçus soit directement, soit par l'intermédiaire du secrétariat de la commission ISO 165.

Cette recommandation finale a été rédigée par la Commission mixte 3TT RILEM/CIB à la suite de l'examen de ces commentaires.

(1) On utilise dans le texte le terme abrégé de « connecteurs métalliques » qui, en langage spécifique, signifie : plaques planes métalliques à dents embouties.

(*) Published in English and in French in "Materiaux et Constructions"
Vol 15, No 88, July-August 1982.

Méthodes d'essai pour assemblages avec systèmes d'attaches mécaniques dans des ossatures porteuses en bois

ANNEXE A

Assemblages par connecteurs métalliques à dents embouties (1)

A.0. INTRODUCTION

Cette annexe a été rédigée afin d'encourager l'utilisation des méthodes d'essais normalisées pour la détermination des propriétés de rigidité et de résistance des assemblages par connecteurs métalliques dans les structures en bois (1).

A.1. DÉFINITIONS

Assemblages par connecteurs métalliques

Une attache à dents formée d'une seule pièce, façonnée à partir d'une plaque métallique d'une épaisseur entre 0,9 et 2,5 mm, munie de projections embouties dans une seule direction et pliées perpendiculairement au plan de la plaque, utilisée comme plaque de jonction pour assembler deux pièces de bois ou plus de la même épaisseur. Pour ceci les dents de la plaque sont totalement enfoncées au moyen d'une presse ou d'un rouleau, afin que la surface de la plaque soit en contact continu avec la surface du bois.

Axe de la plaque

Dans beaucoup de cas la disposition des perforations de la plaque suit deux directions principales perpendiculaires l'une à l'autre, présentant des propriétés mécaniques différentes. La direction qui assure la meilleure résistance à la traction de la plaque est appelée l'axe principal de la plaque.

α : angle entre la direction de la force appliquée et l'axe principal de la plaque ;

β : angle entre la direction de la force appliquée et la direction du fil du bois.

A.2. DOMAINE D'APPLICATION

A.2.1. Ces recommandations constituent une annexe de la recommandation TT-1 : « Méthodes d'essai pour assemblages avec systèmes d'attaches mécaniques dans des ossatures en bois porteuses ».

A.2.2. Cette annexe présente des méthodes d'essais préconisées pour déterminer :

(a) les caractéristiques chargement-glissements et la charge maximale résultant de la résistance latérale des

dents embouties, à divers angles entre la direction de la force appliquée et :

- l'axe de la plaque (angle charge-plaque α),
- la direction du fil du bois (angle charge-fil β),

(b) la résistance à la traction de la plaque à divers angles ;

(c) la résistance à la compression de la plaque à divers angles ;

(d) la résistance au cisaillement de la plaque à divers angles.

A.3. CONDITIONNEMENT DES ÉPROUVETTES

Les éprouvettes seront confectionnées avec du bois à une humidité d'équilibre correspondant à $20 \pm 2^\circ\text{C}$ et une humidité relative de $0,8 \pm 0,05$. Elles seront conservées ensuite pendant au moins 1 semaine à $20 \pm 2^\circ\text{C}$ et $0,65 \pm 0,06$ h. r. ou dans d'autres conditions lorsqu'elles sont appropriées (2).

Les exigences pour le conditionnement des éprouvettes ne s'appliquent pas aux spécimens utilisés pour les essais de résistance de la plaque.

A.4. ÉCHANTILLONNAGE

A.4.1. Les matériaux utilisés pour la confection des éprouvettes seront échantillonnés conformément à la norme ISO 0000 (4).

A.4.2. Pour la détermination de la résistance à la traction, à la compression et au cisaillement de la plaque, la résistance du bois doit être suffisante pour que la rupture se produise dans la plaque.

A.5. FORME ET DIMENSIONS DES ÉPROUVETTES

A.5.1. Dimensions de la plaque

Les dimensions de la plaque à utiliser pour les essais seront sélectionnées dans la gamme de dimensions produites par le fabricant des plaques de telle façon que les valeurs de résistance pour toutes les plaques puissent être obtenues par interpolation avec une fiabilité adéquate.

(2) Se référer à la norme ISO 554 : *Atmosphères normales de conditionnement et/ou d'essai. Spécifications* ainsi qu'aux classes d'humidité définies dans le *Code du calcul du bois de structure* du CIB, 5^e édition, 1980.

(3) Ce document sera préparé par la Commission CIB-W18.

(1) Un code modèle pour la détermination des valeurs caractéristiques de rigidité et de résistance sera rédigé par la Commission CIB-W18 : Structures en bois.

Testing methods for joints with mechanical fasteners in load-bearing timber structures

ANNEX A

Punched metal plate fasteners

A.0. INTRODUCTION

This Annex was produced to encourage the use of standard test methods for determining the stiffness and strength properties of joints made with punched metal plate fasteners in load-bearing timber structures ⁽¹⁾.

A.1. DEFINITIONS

Punched metal plate fastener

An integral nail plate fastener made of metal plate with thickness not less than 0.9 mm and not more than 2.5 mm, having integral projections punched out in one direction and bent perpendicular to the plane of the plate, being used as splice plate to join two or more pieces of timber of the same thickness. For this purpose the projections of the plate are fully embedded, using a press or roller, so that the contact surface of the plate is flush with the surface of the timber.

Axis of the plate

In many cases the punching pattern of the plate gives rise to two main directions perpendicular to each other with different strength properties. The direction giving the highest tensile strength of the plate is called the major axis of the plate.

α : angle between the direction of the applied force and the major axis of the plate;

β : angle between the direction of the applied force and the direction of the grain of the timber.

A.2. SCOPE

A.2.1. These recommendations are an Annex to the Recommendations 3 TT-1: "Testing methods for joints with mechanical fasteners in load-bearing timber structures".

A.2.2. This annex gives preferred test methods for determining:

(a) load-slip characteristics and maximum load resulting from the lateral resistance of the embedded projections, at

various angles between the direction of the applied force and:

- the axis of the plate (load-plate angle α),
- the direction of the grain of the timber (load-grain angle β);
- (b) tensile strength of plate at various angles α ;
- (c) compression strength of plate at various angles α ;
- (d) shear strength of plate at various angles α .

A.3. CONDITIONING OF TEST SPECIMENS

The test specimens shall be manufactured with the timber at an equilibrium moisture content corresponding to $20 \pm 2^\circ\text{C}$ and 0.8 ± 0.05 relative humidity and afterwards shall be conditioned for at least one week at $20 \pm 2^\circ\text{C}$ and 0.65 ± 0.05 r. h. or other condition if appropriate ⁽²⁾.

The requirements for the conditioning of specimens do not apply to specimens for testing plate strength.

A.4. SAMPLING

A.4.1. The materials from which the test specimens will be made must be sampled in accordance with ISO 0000 ⁽³⁾.

A.4.2. For determination of the tensile strength, compression strength and shear strength of plate the timber should be sufficiently strong for failure to occur in the plate.

A.5. FORM AND DIMENSIONS OF TEST SPECIMENS

A.5.1. Size of plate

The sizes of plate to be used for the various tests shall be selected from the range of sizes produced by the manufacturer of the plates in such a way that the strength values for all plates can be obtained with adequate reliability by interpolation.

⁽¹⁾ Standard rules for the determination of characteristic stiffness and strength values will be developed by CIB-W18 "Timber Structures".

⁽²⁾ Attention is drawn to the content of International Standard ISO 554 'Standard Atmospheres for Conditioning and/or Testing - Specifications' and the moisture classes defined in CIB Structural Timber Design Code, 5th edition, 1980.

⁽³⁾ To be prepared by CIB-W18.

A.5.2. Bois

Le bois sera d'une épaisseur d'au moins 33 mm ou deux fois la longueur des dents de la plaque, plus 5 mm, si celle-ci est supérieure (1).

En l'absence d'exigences spéciales, le bois sera raboté et la différence d'épaisseur entre les pièces jointives n'excèdera pas 0,5 mm.

Pour chaque éprouvette, les deux éléments individuels à assembler seront découpés dans la même planche pour assurer une éprouvette équilibrée du point de vue de la masse volumique.

A.5.3. Éprouvettes

Chaque éprouvette sera confectionnée avec deux connecteurs perforés placés en parallèle et symétriquement sur les deux faces opposées de l'assemblage. Les dimensions et la géométrie des éprouvettes seront fonction de la dimension des plaques et de la propriété étudiée.

Les éprouvettes seront assemblées conformément à la méthode (par exemple par presse ou rouleau) normalement utilisée pour ce type de plaque dans la production commerciale des éléments structuraux en bois.

A.6. CARACTÉRISTIQUES DE CHARGEMENT-GLISSEMENT DE L'ASSEMBLAGE : CHARGE MAXIMALE A LA SURFACE DE CONTACT ENTRE LA PLAQUE ET LE BOIS

A.6.1. Force appliquée parallèle au fil du bois

A.6.1.1. ÉPROUVETTES

La charge maximale due à la résistance latérale des dents de la plaque lorsque la charge est appliquée dans une direction parallèle au fil du bois sera déterminée au moyen de l'éprouvette présentée à la figure 1.

Les essais seront effectués avec un angle α de 0, 30, 60 et 90 (2).

La longueur de l'éprouvette sera telle que les extrémités des mordaches de la machine d'essai seront à 200 mm au moins des extrémités de la plaque. Si besoin est, on peut renforcer les extrémités de l'éprouvette pour empêcher toute rupture prématurée à l'endroit des mordaches. En général, les connecteurs comportent des dents multiples disposées de façon modulaire; il suffit de soumettre à l'essai une dimension de plaque à chaque angle α . Les dimensions de la plaque seront telles que sa dimension dans la direction de la force appliquée soit la plus grande pour laquelle la rupture se produit dans la liaison bois-dent (3).

Les plaques seront enfoncées en veillant à ne briser aucune dent.

(1) Les données d'essais ne seront pas appliquées aux assemblages comportant des éléments d'une épaisseur inférieure à ceux soumis à l'essai, mais elles pourront être appliquées aux assemblages comportant des éléments plus épais.

(2) Soumettre à l'essai au moins 10 éprouvettes de chaque type pour permettre un traitement statistique des résultats.

(3) La sélection de la dimension appropriée de la plaque peut souvent être effectuée sur la base d'expérience de plaques semblables. Cependant, des essais préliminaires seront quelquefois nécessaires.

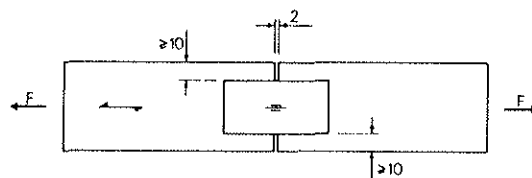

Fig. 1a $\alpha = 0^\circ$ $\beta = 0^\circ$

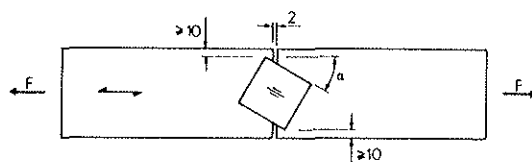

Fig. 1b $\alpha = 30^\circ$ $\beta = 0^\circ$

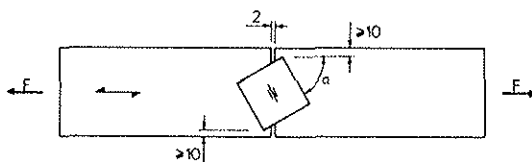

Fig. 1c $\alpha = 60^\circ$ $\beta = 0^\circ$

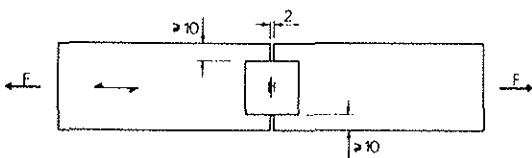

Fig. 1d $\alpha = 90^\circ$ $\beta = 0^\circ$

← Fil du bois
 ≡ Axe principal de la plaque (voir § A 1)

Fig. 1. - Éprouvette pour l'essai des caractéristiques de chargement-glisement et charge maximale : force appliquée parallèle au fil du bois.

Les pièces en bois pour les éprouvettes seront découpées de façon à éviter tout défaut : nœuds, fils irréguliers, fissures, flaches, dans les zones d'enfoncement. Ailleurs les éléments seront exempts de défauts majeurs qui risqueraient d'entraîner une rupture prématurée dans le bois.

A.6.1.2. CHARGEMENT

Appliquer la charge et noter les glissements selon la recommandation TT-1, article 7.

A.6.1.3. RESULTATS

Noter les glissements et la charge maximale pour chaque éprouvette conformément aux recommandations de la TT-1, article 7.

A.6.2. Force appliquée perpendiculairement au fil

A.6.2.1. ÉPROUVETTE

La charge maximale due à la résistance latérale des dents de la plaque avec la charge appliquée perpendiculairement au fil du bois sera déterminée au moyen de l'éprouvette présentée dans la figure 2.

Effectuer les essais avec $\alpha=0$ et 90° (4).

La longueur du bois en about chargé en traction sera telle que l'extrémité de la mordache de la machine d'essai

(4) Soumettre à l'essai au moins 10 éprouvettes de chaque type pour permettre un traitement statistique des résultats.

A.5.2. Timber

The timber shall have a thickness of not less than 33 mm or twice the length of the plate projections plus 5 mm if this is greater ⁽¹⁾.

If there are no special requirements the timber shall be planed and the difference in thickness between adjoining pieces shall not exceed 0.5 mm.

For each specimen, the two individual members to be joined shall be cut from the same plank to ensure a balanced specimen for density.

A.5.3. Test specimens

Each test specimen shall be made with two punched metal plate fasteners positioned parallel to each other and symmetrically on opposite faces of the joint. The size and geometry of the specimens will depend upon plate size and the property being measured.

The specimens shall be assembled using the method (eg press or roller) normally used with the particular fasteners in the commercial production of structural timber components.

A.6. LOAD-SLIP CHARACTERISTICS OF THE JOINT; MAXIMUM LOAD AT CONTACT SURFACE OF PLATE AND TIMBER

A.6.1. Applied force parallel to grain

A.6.1.1. TEST SPECIMEN

The maximum load due to the lateral resistance of the plate projections, with the load applied in a direction parallel to the grain of the timber shall be determined using the test specimen shown in figure 1.

Tests shall be carried out with angle $\alpha=0, 30, 60$ and 90° ⁽²⁾.

The length of the specimen shall be such that the ends of the testing machine grips shall be not less than 200 mm from the ends of the plates. Where necessary the ends of the specimen may be reinforced to avoid premature failure at the grips.

Generally punched metal plate fasteners have multiple projections in a modular arrangement and it will be sufficient to test one size of fastener at each angle α . The size of the fastener should be such that its dimension in the direction of the applied force is the largest for which failure at the embedded projections will occur ⁽³⁾.

The plates must be embedded without removal of any teeth.

Timber members for the specimens shall be cut so that the areas into which the fasteners are embedded are free from knots, local grain disturbance, fissures and wane. Elsewhere the members shall be free from major defects which could lead to premature failure in the timber.

⁽¹⁾ Test data should not be applied to joints with members thinner than those tested, but may be applied to joints with thicker members.

⁽²⁾ At least 10 specimens of each type shall be tested to permit a statistical treatment of the results.

⁽³⁾ The selection of the appropriate size of plate may often be made on the basis of experience with similar fasteners. However, preliminary tests may sometimes be required.

A.6.1.2. LOADING

The load shall be applied and slips recorded as recommended in 3 TT-1, clause 7.

A.6.1.3. RESULTS

The slips and maximum load for each test specimen shall be recorded as recommended in 3 TT-1, clause 7.

A.6.2. Applied force perpendicular to grain

A.6.2.1. TEST SPECIMEN

The maximum load due to the lateral resistance of the plate projections, with the load applied perpendicular to the grain of the timber, shall be determined using the test specimen shown in figure 2.

Tests shall be made with $\alpha=0$ and 90° ⁽⁴⁾.

The length of the abutting timber loaded in tension shall be such that the end of the testing machine grip shall be not less than 200 mm from the ends of the plates.

⁽⁴⁾ At least 10 specimens of each type shall be tested to permit a statistical treatment of the results.

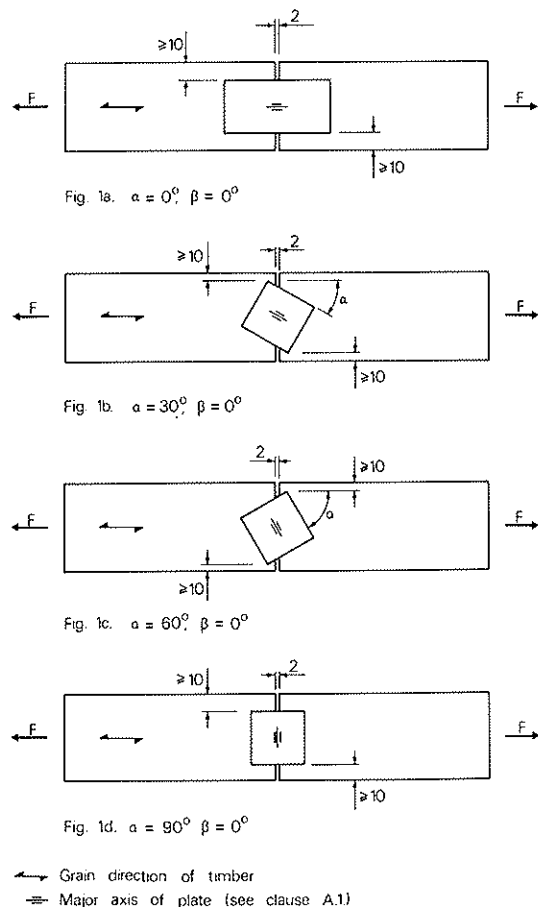

Fig. 1. - Specimen for load-slip; characteristic and maximum load; force parallel to grain.

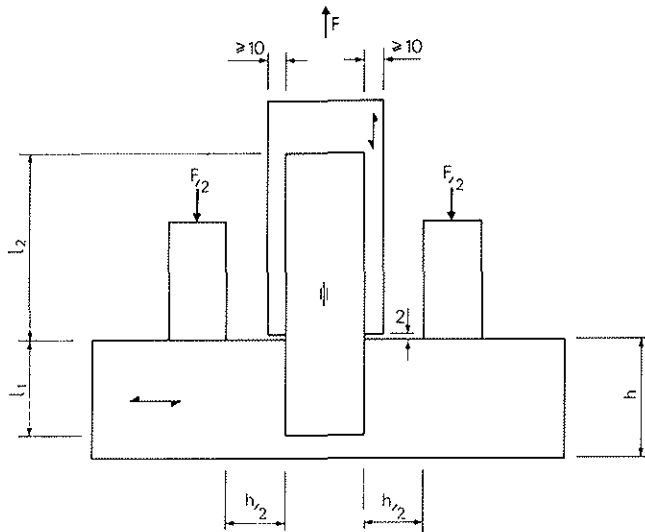

Fig. 2. - Éprouvette pour l'essai des caractéristiques de chargement-glisement : force appliquée perpendiculairement au fil du bois. $\alpha=0^\circ$ et 90° ; $\beta=90^\circ$.

se trouve à une distance égale ou supérieure à 200 mm des extrémités des plaques.

Les plaques seront placées pour favoriser la rupture dans les dents enfoncées dans l'élément chargé perpendiculairement au fil du bois, c'est-à-dire dans l'élément transversal. Normalement la rupture se produit lorsque $h_1 < h_2$; pour réduire au minimum le fendage de l'élément transversal h_1 doit être égal à h .

A.6.2.2. CHARGEMENT

Appliquer la charge et noter les glissements selon la recommandation TT-1, article 7.

A.6.2.3. RÉSULTATS

Noter les glissements et la charge maximale pour chaque éprouvette selon la recommandation TT-1, article 7.

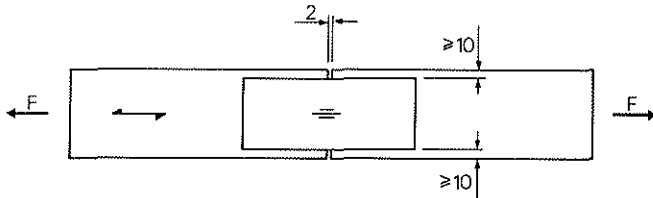

Fig. 3. - Éprouvette pour l'essai de la résistance à la traction de la plaque. $\alpha=0$ et 90° ; $\beta=0^\circ$.

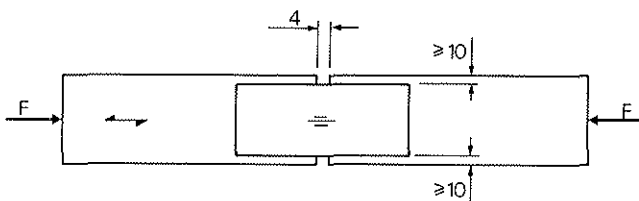

Fig. 4. - Éprouvette pour l'essai de la résistance à la compression de la plaque. $\alpha=90^\circ$; $\beta=0^\circ$.

A.7. RÉSISTANCE A LA TRACTION DE LA PLAQUE

A.7.1. Éprouvette

La résistance à la traction de la plaque sera déterminée au moyen de l'éprouvette présentée à la figure 3.

Effectuer les essais aux angles $\alpha=0$ et 90° et $\beta=0^\circ$ ⁽¹⁾.

Choisir la longueur de la plaque et les dimensions en section transversale du bois sur la base des résultats constatés en A. 6 pour s'assurer que la rupture se produise dans la plaque.

La section la moins résistante près de la ligne centrale de la plaque doit se trouver à l'endroit du joint entre les éléments en bois de l'assemblage.

A.7.2. Chargement

En règle générale la charge sera appliquée selon la recommandation TT-1, article 7; toutefois le cycle de préchargement au début de la séquence de chargement peut être omis.

A.7.3. Résultats

Noter la charge maximale pour chaque éprouvette.

A.8. RÉSISTANCE A LA COMPRESSION DE LA PLAQUE

A.8.1. Éprouvettes

La résistance à la compression de la plaque sera déterminée au moyen de l'éprouvette présentée à la figure 4. La longueur de la plaque et les dimensions transversales du bois seront choisies en fonction des résultats de l'essai A. 6 pour s'assurer la rupture de la plaque.

Effectuer les essais aux angles $\alpha=0$ et 90° ; $\beta=0^\circ$ ⁽²⁾.

La section la moins résistante près de la ligne centrale de la plaque doit se trouver à l'endroit du joint entre les éléments en bois de l'assemblage.

A.8.2. Chargement

En règle générale appliquer la charge selon la recommandation TT-1, article 7; toutefois, le cycle de préchargement au début de la séquence de chargement peut être omis.

A.8.3. Résultats

Noter la charge maximale pour chaque éprouvette. La charge de compression maximale sera la charge requise pour fermer l'écart entre les éléments de bois.

⁽¹⁾ Trois éprouvettes de chaque type doivent suffire à condition que toutes subissent le même mode de rupture.

⁽²⁾ Il doit suffire de soumettre à l'essai au moins trois éprouvettes de chaque type, à condition d'obtenir des ruptures de plaques satisfaisantes.

The plates shall be positioned to favour failure at the plate projections embedded in the member loaded perpendicular to the grain of the timber, i. e. in the cross-member. This will normally occur when $h_1 < l_2$ and in order in order to minimise splitting of the cross-member, h_1 should be equal to h .

A. 6. 2. 2. LOADING

The load shall be applied and slips recorded as recommended in 3TT-1, clause 7.

A. 6. 2. 3. RESULTS

The slips and maximum load for each test specimen shall be recorded as recommended in 3TT-1, clause 7.

A. 7. PLATE TENSILE STRENGTH

A. 7. 1. Test specimen

Plate tensile strength shall be determined using the test specimen shown in figure 3.

Tests shall be made with $\alpha=0$ and 90° ; $\beta=0^\circ$ ⁽¹⁾.

The length of the plate and the cross-section dimensions of the timber shall be chosen on the basis of the results found in A. 6 to ensure that failure occurs in the plate.

The weakest cross-section near the plate centre-line should be over the gap between the timber members of the joint.

A 7. 2. Loading

Load shall be applied generally in accordance with 3TT-1, clause 7 except that the pre-load cycle at the beginning of the loading sequence may be omitted.

⁽¹⁾ Three specimens of each type should be a sufficient number to test provided all achieve the same mode of failure.

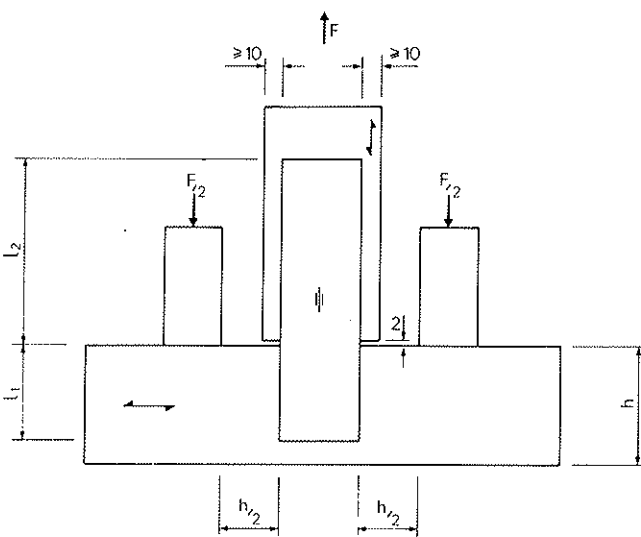

Fig. 2. - Specimen for maximum load and load-slip characteristics force perpendicular to grain. $\alpha=0$ and 90° ; $\beta=90^\circ$.

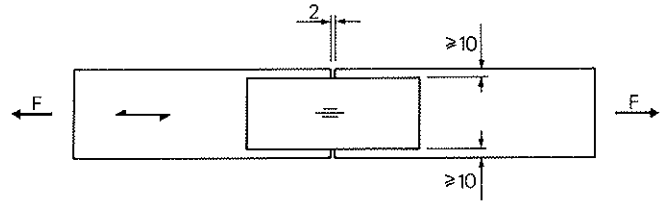

Fig. 3. - Specimen for plate tensile strength. $\alpha=0$ and 90° ; $\beta=0^\circ$.

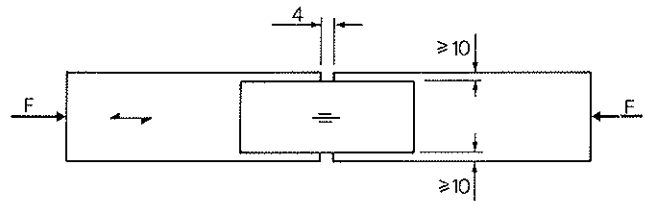

Fig. 4. - Specimen for plate compression strength. $\alpha=0$ and 90° ; $\beta=0^\circ$.

A. 7. 3. Results

The maximum load for each test specimen shall be recorded.

A. 8. PLATE COMPRESSION STRENGTH

A. 8. 1. Test specimen

Plate compression strength shall be determined using the test specimen shown in figure 4. The length of the plate and the cross-section dimensions of the timber shall be chosen on the basis of the results from A. 6 to ensure that failure of the plate will occur.

Tests shall be made with $\alpha=0$ and 90° ; $\beta=0^\circ$ ⁽²⁾.

The weakest cross-section near the plate centre-line should be over the gap between the timber members of the joint.

A. 8. 2. Loading

Load shall be applied generally in accordance with 3TT-1, clause 7 except that the pre-load cycle at the beginning of the loading sequence may be omitted.

A. 8. 3. Results

The maximum load for each test specimen shall be recorded. The maximum compression load shall be taken as the load required to close the gap between the timber members.

⁽²⁾ It should be sufficient to test at least three specimens of each type, provided satisfactory plate failures are achieved.

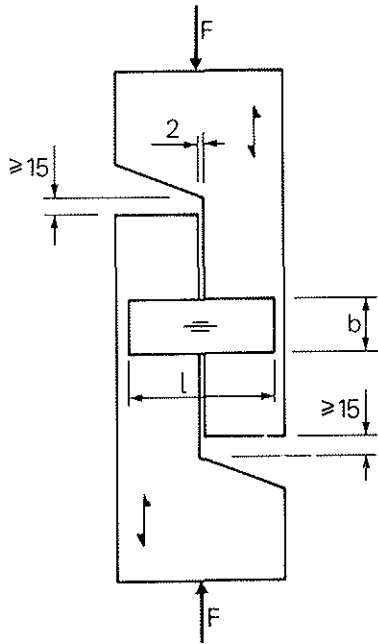

Fig. 5 - Éprouvette pour l'essai de la résistance au cisaillement de la plaque. $\alpha=90^\circ$; $\beta=0^\circ$.

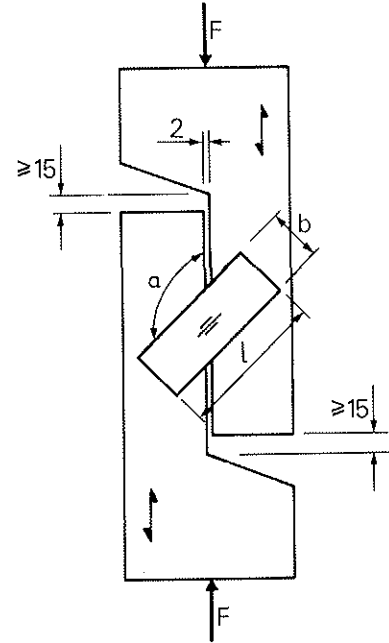

Fig. 7. - Éprouvette pour l'essai de la résistance au cisaillement de la plaque. $\alpha=105, 120, 135, 150$ et 165° ; $\beta=0^\circ$.

A.9. RÉSISTANCE DE LA PLAQUE AU CISAILLEMENT

A.9.1. Éprouvette

La résistance de la plaque au cisaillement sera déterminée au moyen d'éprouvettes présentées aux figures 5, 6, 7 et 8.

L'épaisseur des pièces en bois sera choisie pour assurer une rupture dans la plaque (une épaisseur d'approximativement 45 mm convient pour les bois tendres européens).

En général, les essais seront effectués à l'angle α selon les figures et à l'angle $\beta=0^\circ$.

Cependant, en présence de méthodes analytiques adéquates, on peut limiter les essais à $\alpha=0$ et 90° ⁽¹⁾.

⁽¹⁾ Il doit suffire de soumettre à l'essai au moins trois éprouvettes de chaque type à condition d'obtenir des ruptures de plaque satisfaisantes.

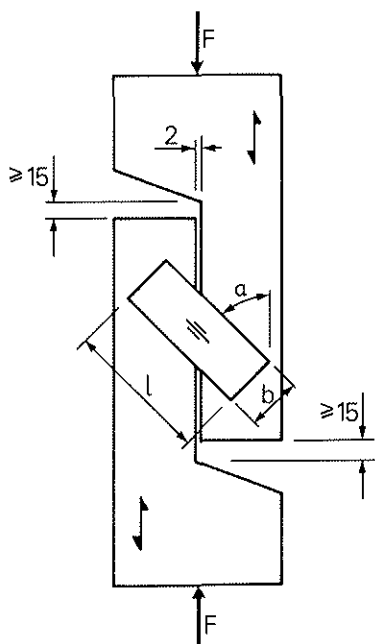

Fig. 6. - Éprouvette pour l'essai de la résistance au cisaillement de la plaque. $\alpha=15, 30, 45, 60$ et 75° ; $\beta=0^\circ$.

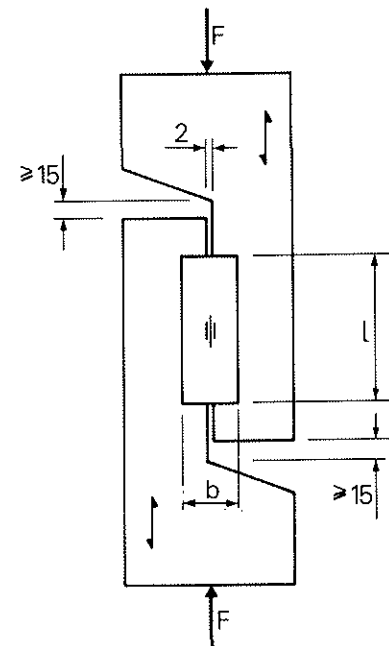

Fig. 8. - Éprouvette pour l'essai de la résistance au cisaillement de la plaque. $\alpha=0^\circ$; $\beta=0^\circ$ dans chaque cas avec variation du rapport l/b au moyen d'essais sur des plaques de dimensions différentes.

A.9. PLATE SHEAR STRENGTH

A.9.1. Test specimen

The plate shear strength shall be determined using test specimens as shown in figures 5, 6, 7 and 8. The thickness of the timber members should be chosen so that failure will

occur in the plate (approximately 45 mm is usual for European softwood).

In general, tests should be carried out with the angle α as shown on the figures, and $\beta=0$. However, where adequate analytical methods are available the tests may be limited to $\alpha=0$ and 90° ⁽¹⁾.

⁽¹⁾ It should be sufficient to test at least three specimens of each type provided satisfactory plate failures are achieved.

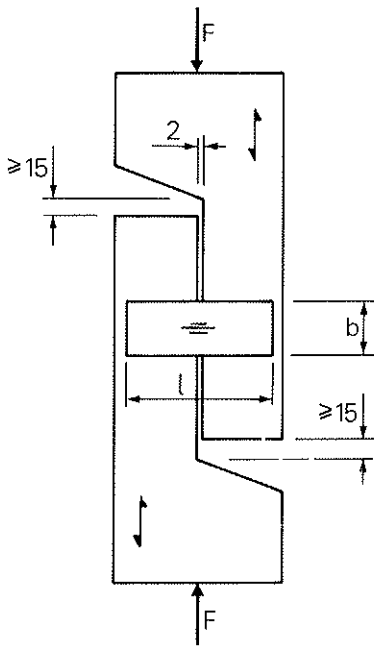

Fig. 5. - Specimen for plate shear strength. $\alpha=90^\circ$; $\beta=0^\circ$.

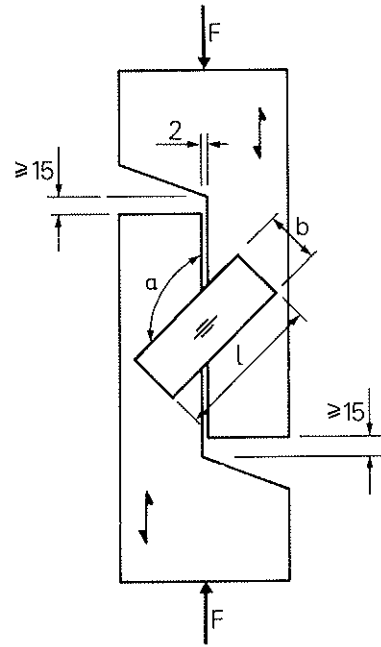

Fig. 7. - Specimen for plate shear strength. $\alpha=105, 120, 135, 150$ and 165° ; $\beta=0^\circ$.

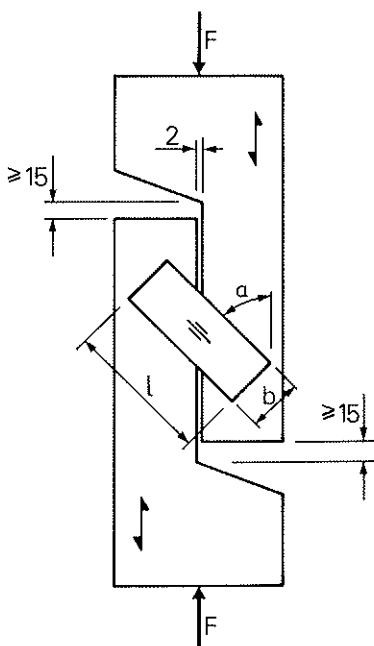

Fig. 6. - Specimen for plate shear strength. $\alpha=15, 30, 45, 60$ and 75° ; $\beta=0^\circ$.

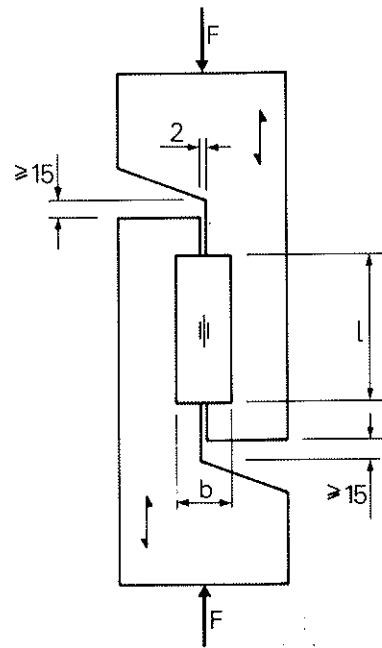

Fig. 8. - Specimen for plate shear strength. $\alpha=0^\circ$; $\beta=0^\circ$ in each case with variation of the ratio l/b by tests on additional plate sizes.

A.9.2. Chargement

En règle générale, la charge sera appliquée conformément à la recommandation TT-1, article 7 ; toutefois, le cycle de préchargement au début de la séquence de chargement peut être omis.

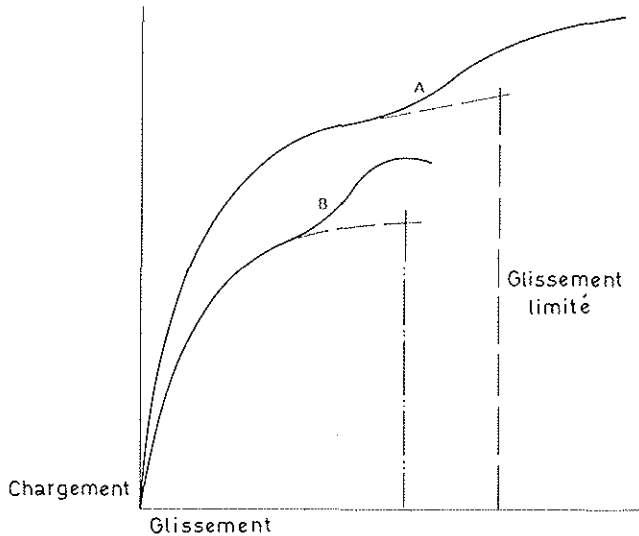

Fig. 9. – Courbes chargement-cisaillement pour l'essai de cisaillement ; les courbes sont extrapolées de la limite apparente d'élasticité pour donner des valeurs supposées de la charge maximale A où la charge maximale n'est pas notée avant d'atteindre le glissement limite approprié et B où la charge maximale d'essai est notée à une valeur de glissement inférieure à la valeur limite.

A.9.3. Résultats

Noter la charge maximale pour chaque éprouvette. La charge maximale en cisaillement sera la charge la plus élevée exercée pour un glissement entre les pièces d'assemblage n'excédant pas 6,0 mm ou six fois l'épaisseur de la plaque, en prenant la valeur la plus élevée. Toutefois, dans le cas d'une « limite apparente d'élasticité » nette dans la courbe chargement-glissement (plus probablement avec $\alpha=90^\circ$), la montée ultérieure de charge ne doit pas être prise en considération mais la courbe chargement-glissement sera extrapolée en courbe lisse jusqu'à la limite de glissement appropriée et la valeur de charge à ce point prise comme valeur maximale. Ce calage est présenté dans la figure 9.

A.10. PROPRIÉTÉS DES MATÉRIAUX

A.10.1. Plaques

La résistance à la traction, la limite apparente d'élasticité, l'allongement et la dureté de l'acier utilisé pour la fabrication des plaques, mesurés avant l'emboutissage, doivent être déterminés selon les modes opératoires courants.

A.10.2. Bois ; teneur en humidité, masse volumique, espèces.

La teneur en humidité du bois sera déterminée selon ISO 3130 et la masse volumique selon ISO 3131. L'identité des espèces sera confirmée par examen anatomique.

A.11. Rapport d'essai

Le rapport d'essai fera état des informations appropriées conformément à la recommandation TT-1, article 8.

A.9.2. Loading

Load shall be applied generally in accordance with 3TT-1, clause 7 except that the pre-load cycle at the beginning of the loading sequence may be omitted.

A.9.3. Results

The maximum load for each test specimen shall be recorded.

The maximum shear load shall be taken as the highest load reached for a slip between the joint members of not greater than 6.0 mm or six times the plate thickness, whichever is the larger. However, if a distinct 'yield point' occurs in the load-slip curve (most likely with $\alpha=90^\circ$), the subsequent rise in load shall not be taken into account but the load-slip curve shall be extrapolated in a smooth curve to the appropriate slip limit and the load value at this point taken as the maximum. This adjustment is shown in figure 9.

A.10. MATERIAL PROPERTIES

A.10.1. Plates

The tensile strength, yield stress, elongation and hardness of the steel used to manufacture the plates, and before punching, should be determined using standard test procedures.

A.10.2. Timber ; moisture content, density, species

The moisture content of the timber shall be determined in accordance with ISO 3130, and its density in accordance with ISO 3131.

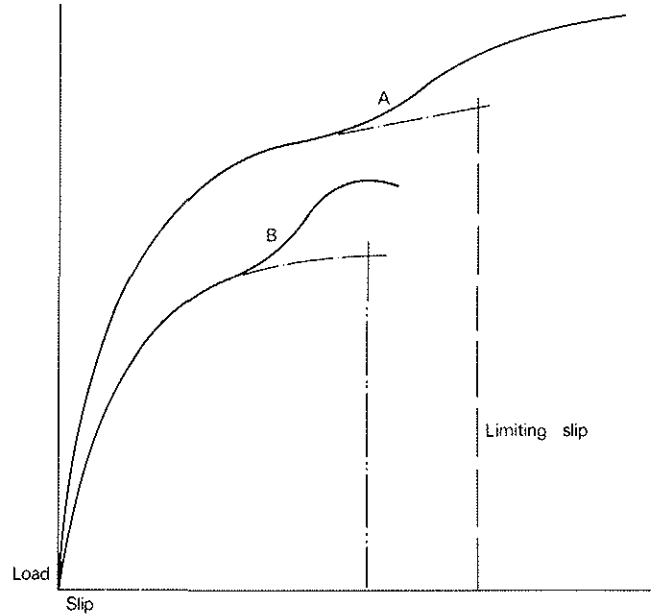
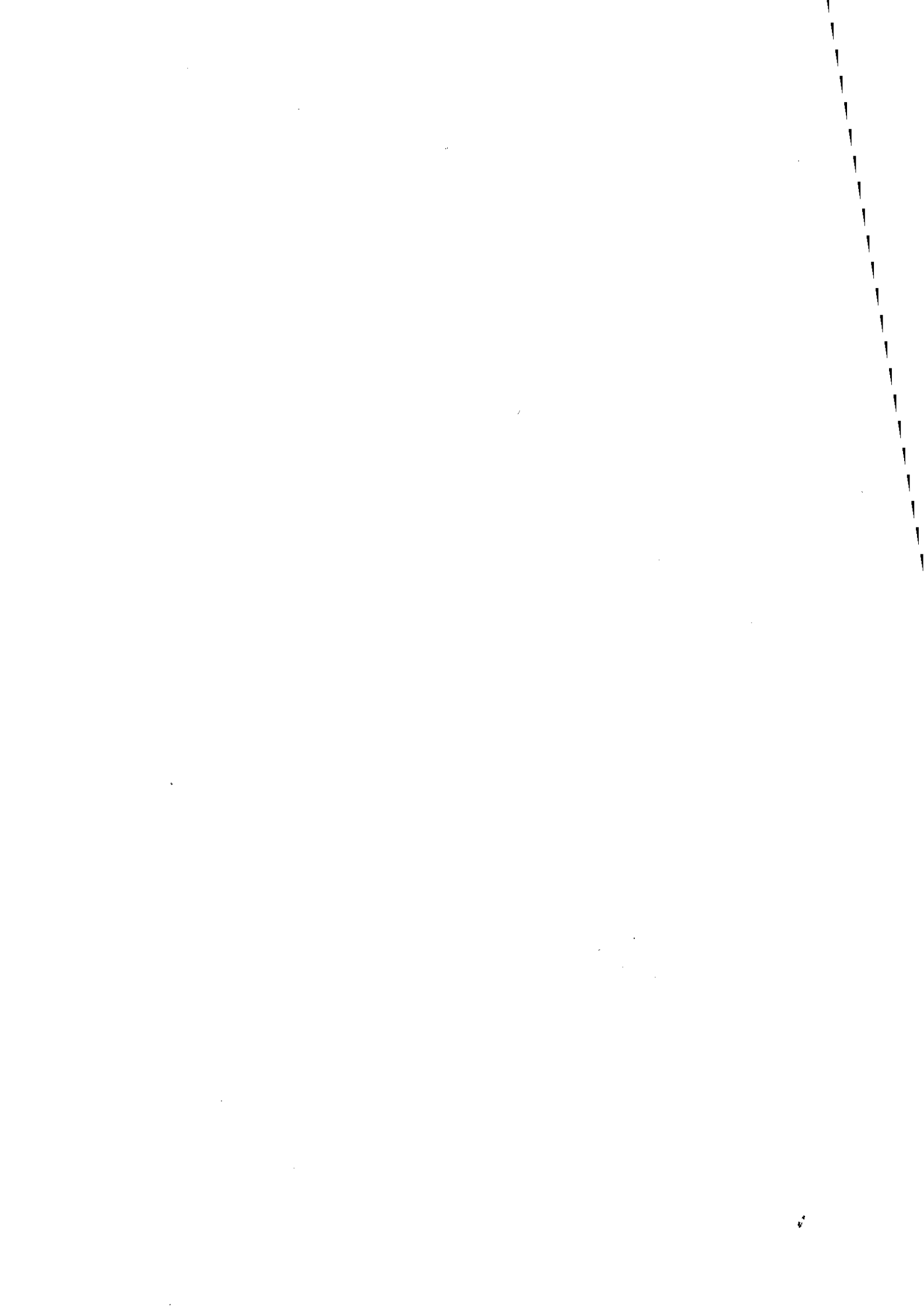

Fig. 9. - Load-slip curves for shear test were the curves extrapolated from yield to give assumed values of maximum load, A where the maximum load is not recorded before the appropriate limiting slip is reached and B where the test maximum load is recorded at a slip less than the limiting value.

The identity of the species shall be confirmed by botanical examination.

A.11. TEST REPORT

The test report shall include the relevant information recommended in 3TT-1, clause 8.



INTERNATIONAL COUNCIL FOR BUILDING RESEARCH STUDIES AND DOCUMENTATION

WORKING COMMISSION W18 - TIMBER STRUCTURES

GUIDELINES FOR STATIC MODELS OF
TRUSSED RAFTERS

by

H Riberholt

(Nordic Timber Truss Group)

KARLSRUHE
FEDERAL REPUBLIC OF GERMANY

JUNE 1982

INTERNATIONAL COUNCIL FOR BUILDING RESEARCH STUDIES AND DOCUMENTATION.

WORKING COMMISSION W 18 - TIMBER STRUCTURES.

CIB W.18/15-14-1

Guidelines for Static Models of
Trussed Rafters

Nordic Timber Truss Group

(H. Riberholt)

KARLSRUHE

June 1982

DEFINITIONS

Connection:

Domain where timber parts and/or nail plates are in contact in such a way that forces may be transferred between the parts. In the following examples and in chap. 2.4.1 and 2.4.2 the connection domains are hatched.

Node:

Intersection point of system lines of beam elements.

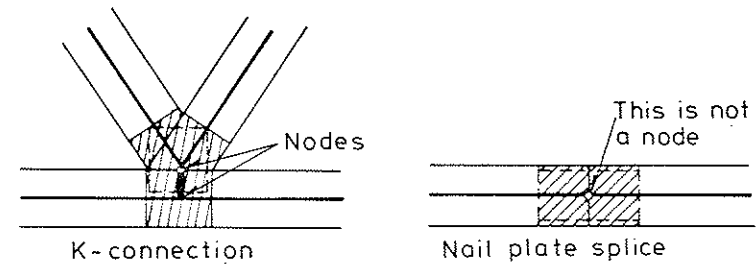

Bay:

Structure (timber beam) between two neighbouring nodes.

Beam element:

Model of a timber part.

Fictitious beam element:

Beam element, employed in connections in order to model their static behaviour.

GUIDELINES FOR STATIC MODELS OF TRUSSED RAFTERS.

1. INTRODUCTION

1.1 Object.

The object of the guidelines is to constitute a basis for the static modelling of timber trussed rafters. The static models are intended used for analysis of stresses and deflections.

The scope of the guidelines are primarily plane trusses with nail plate connections. But they may be applied to trusses with other types of connectors with similar static behaviour.

1.2 General.

Static calculations of timber trusses may be formulated at different levels, depending on how close the calculation model is to reality. By the elaboration of the present guidelines there are aimed at two levels:

1. A simplified practical calculation method, which can be carried out by hand.
2. A general applicable method based on a linear elastic frame model.

In chapter 2 there are given guidelines for the general applicable model, level 2. Chapter 5 and subsequent chapters contain simplified practical methods. These are formulated so that they give approximately the same results as the level 2 method, maybe a little on the safe side.

The guidelines take into account the important effects, which (normally) have influence on forces and moments in the timber parts and the connections. In the notes there are given explanations for some of the approximations.

Note. The guidelines are worked out with regard to the following two facts.

First: The dimensioning of the truss must be done as a sequence of operations, namely: 1. Analysis of forces and moments independent of the detailed design of the nail plate connections - 2. Dimensioning of the timber - 3.

Dimensioning of the nail plate connections.

This implies that the models of the connections must be very simple.

Second: The guidelines are worked out so that the dimensioning may be performed by means of normal available methods.

2. FRAME MODEL

2.1 General, level 2 method.

The static model of a timber truss consists of linear elastic beam elements, which are connected by stiff or pinned joints dependent on the static behaviour of the connections.

By the calculation of forces and moments the elongation of the timber parts must be taken into account. It is acceptable to neglect the deformations in the connections, when the structure height is larger than the one tenth of the span.

The deformations of the connections contribute to the deflection of the truss. Their contribution may be calculated as described in [Calculation of deflections of timber trusses]. Typical deformations in nail plate connections are given in [Design of joints with nail plates].

These guidelines cover only the dimensioning of timber cross sections between the connections, in moment resisting connections and in continuous chords. The dimensioning of the connections must include the necessary requirements to the strength of the timber in the connection domain, e.g. splitting.

When the system lines of the beam elements do not coincide with the centre of gravity of the timber, then it must be taken into account by the dimensioning of the timber parts.

2.2 Geometry of the model.

As a principal rule the system lines of the beam elements outside the connections must coincide with the centre of gravity of the timber parts. For the chords this must always be the case.

When the system lines in a connection do not intersect in one point fictitious beam elements are introduced. These are connected to the other beam elements so that the static behaviour of the connection is modelled in the best possible way. The proposed models in chapter 2.4 can be employed if no better can be established.

In the lattice the system lines of the beam elements do not need to coincide with the centre of gravity of the timber parts. However, the system lines shall lie within the cross section of the timber.

2.3 Physical properties.

As a principal rule the beam elements may be assumed to be linear elastic.

2.3.1 Beam elements modelling timber

The stiffnesses EA and EI are calculated based on the actual timber dimensions and qualities.

Where it can be justified by tests, compressed beams may be assumed to behave elasto-plastic with limited rotation capacity. This is the case for the top chord at the heel joint in cantilevered W- and WW-trusses where the height of the top chord exceeds that of the bottom chord but with no more than 25 mm.

2.3.2 Fictitious beam elements

The fictitious beam elements are assigned stiffnesses of approximately the same order as that of the adjacent beam elements.

2.3.3 Connections

The static behaviour of the connections are pronounced non-linear, but no closer knowledge of that is required in the model proposed.

Note. If the deformations in a connection are taken into account, these must be determined from how big the actions are compared with the strength of the connection. If the static analysis is used for the dimensioning of the timber the deformations must correspond to forces equal to 60% of the

strength of the connection, unless the nail plate connection is substantial overdimensioned.

2.4 Static models of the connections.

In the guidelines the connections are modelled as either pinned or moment stiff joints. There can be deviated from this if it is based on tests.

The position of a pinned joint should be so that it is in accordance with the force distribution employed in the static analysis of the connection. Chapter 2.4.1 shows some examples.

In particular cases the connections can be modelled as moment transferring. Chapter 2.4.2 shows some examples.

2.4.1 Examples of pinned connections

The connections can be characterized thereby that they are only dimensioned for forces and maybe small internal eccentricity moments. They have, therefore, no capacity to transfer moments.

In the following examples the thick system lines symbolize fictitious beam elements.

CONNECTIONS WITH 2 PLATE AREAS:

Lattice - chord

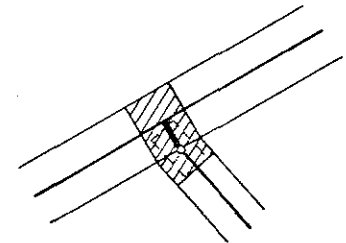

Lattice - chord
No essential shear force in the diagonal.

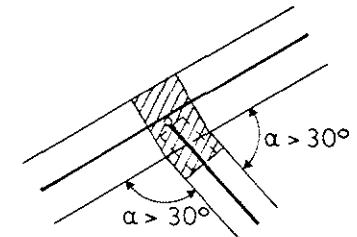

Arbitrary splice.

Tension: The plate connection shall transfer the total force

Compr.: The plate connection shall transfer 2/3 of the total force

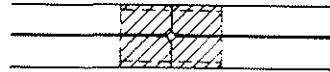

Bend connection in the chords

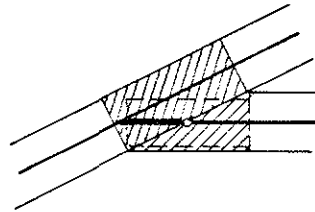

CONNECTIONS WITH 3 PLATE AREAS:

Lattice - chord
small nail plates

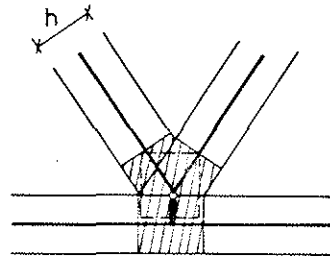

Lattice - chord.

The nail plates must be capable to transfer the eccentric forces.

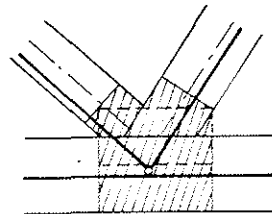

Bend connection in the chords

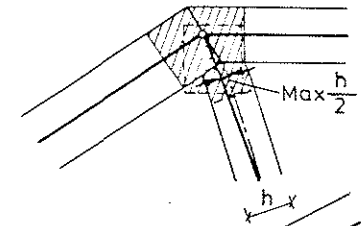

Heel joint with a high wedge

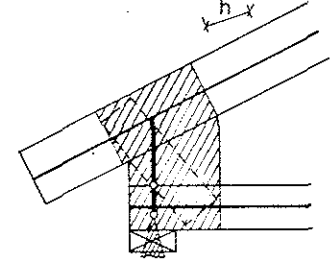

CONNECTIONS WITH 4 PLATE AREAS:

Ridge connection

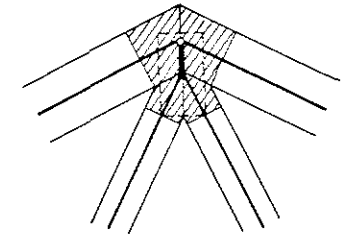

Bend connection in the chords

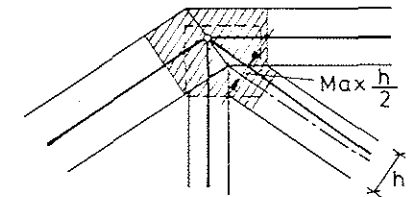

CONNECTIONS WITH 5 PLATE AREAS:

Connection in scissor truss

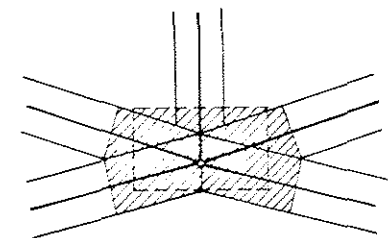

2.4.2 Examples of moment transferring connections

This chapter contains examples of connections where the rotation between the timber parts is coupled.

The heel joint can be modelled as shown in the following examples, provided it is subjected to an outer force which creates compression in the joint between the timber parts. It is therefore assumed that the force intersects the contact area.

Above the support area there must always be contact between the top and bottom chord, for example by a wedge. If the height of the wedge h_w is larger than 200 mm, the grain direction in the chord should be perpendicular to the chord.

The wedge must be kept in position by nail plats.

Heel joint, centric supported

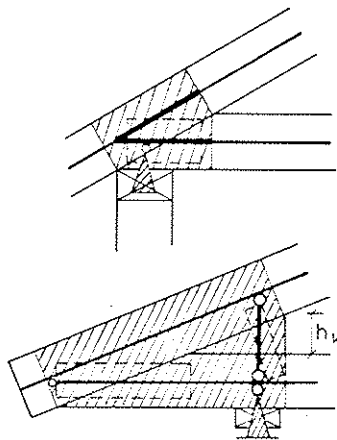

Heel joints, cantilevered

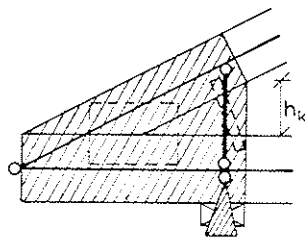

Splice in the chord

The connection may be assumed stiff either if it is placed 0.05·bay length from the moment zero point or if it is dimensioned for the normal force plus 1.5·calculated moment.



2.5 Supports

Unless the supports are designed specially they can be assumed to behave as pinned joints positioned in the middle of the support areas.

For trusses with both top and bottom chords, it can be assumed that vertical loads are taken by one firm simple support and the other supports being pinned joints on rollers. For horizontal load all the supports can be assumed to behave as pinned joints on rollers but kept in position by springs, which are assigned stiffnesses, corresponding to that of the supporting structures.

2.6 Loadings and statics

The trusses must be dimensioned for the loads provided by the national codes. In principle, the truss must be subjected to the loads as they act in reality. For example, in a roof with purlins, the truss must in principle be loaded by concentrated forces.

A row of concentrated forces may be equated to a distributed line load if the difference between the moments from the two loading cases is less than 10%, or if it is on the safe side.

Note: For lattice trusses the concentrated loads from purlins with equivalent distances can be equated with a distributed line load if the distance between the purlins is less than 40% of the bay length.

Larger concentrated forces, including reactions, must be applied where they act in reality.

It is acceptable that the analysis of forces and moments is done by

a first order theory, i.e. that equilibrium is fulfilled in the undeformed state, if the column effect is considered at the dimensioning of the timber members.

For lattice trusses it is acceptable to undertake the strength dimensioning for the loading case "dead load + man load F" in the following way.

$$\sigma = \frac{1}{4} \frac{F \ell}{W} \leq f_m$$

where ℓ is the horizontal bay length. (i.e. the small normal forces are neglected).

2.6.1 Reduced column lengths

For bars or beams over one bay and without a special stiff connection to the nodes the reduced column length is equated to the length between the nodes.

For continuous beams with a distributed lateral line load of constant intensity along the total length, the following reduced column lengths are valid. A continuous beam is a beam either without splices over several bays or with splices positioned so that the compressed beam would be stable even if all the splices behaved as pinned joints. It is further assumed that the splices are positioned at the moment zero points.

For continuous beams with lateral load but without essential end moments the following reduced column lengths are valid.

- In an outer bay : 0.8·bay length
- In an inner bay : 0.6·bay length
- At a node : 0.6·largest adjacent bay length

Reduced column lengths related to the bay lengths or the largest adjacent bay length.

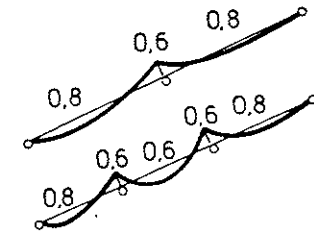

For continuous beams with lateral load and an essential end moment the following reduced column lengths are valid.

- Beam end with moment : 0.0, i.e. no column effect
- In the bay second from the end : 1.0 bay length
- Remaining bays and nodes : As described above

Reduced column lengths related to the bay lengths.

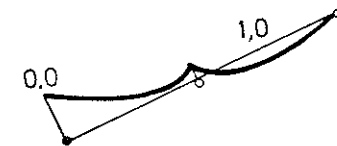

For continuous beams without lateral load (centrally loaded columns) the reduced column lengths may be assumed equal to the bay length.

2.7 Examples of static models

The examples will be described later on.

3. REQUIREMENTS TO THE PRODUCTION OF TRUSSES

Besides the requirements in the timber design code the following must be fulfilled.

The timber parts must touch each other in at least one point. Under the nail plates the gap in the joint must not exceed 2 mm.

- *) The position of the nail plates must be within the tolerances ±5 mm and the effective anchorage area must never be less than 90% of the necessary.
- *) The nail plates must be pressed close to the timber in 75% of the plate area. The gap between nail plate and timber must never exceed 2 mm.

After the pressing of the nail plates there must in the timber not occur essential splitting or crushing marks.

The trusses must be marked with text showing:

- Maximum truss distance c-c mm
- Lateral bracing of lattice, if any
- Support area of the bottom chord with a tolerance of ±10 mm

The nail plate connections must be capable to withstand the transport of the trusses.

When the truss lies down the splices in the chords must be capable to resist the moments or they must have a moment capacity equal to that of the chords.

*) Clauses may be omitted here if they are given elsewhere

4. REQUIREMENTS TO THE FINISHED STRUCTURE

It must be secured that in the finished structure the trusses have a behaviour equal to that assumed in the static model.

A proper lateral bracing must be established during the erection and in the finished structure (Requirements, proposals).

If there are partitions right below the bottom chord it must be secured that this do not break when the truss deflects. This may be assumed fulfilled when

5. SIMPLIFIED ANALYSIS METHODS

This chapter contains simplified analysis methods applicable to common truss types and elaborated with reference to hand calculations.

Instead of using a frame model the normal forces can be found under the assumption that all the connections in the lattice truss act as pinned joints loaded with nodal forces. These are found by means of some approximate equilibrium requirements.

The moments in the chords can be found from

Distributed line loads:

$$M = \text{mom. coeff.} \cdot ql^2$$

where

mom. coeff. are given in chapter 5.1 - 5.5

q Distributed line load

l Bay length

Concentrated forces:

$$M = ?$$

The strength analysis is carried out as described in the previous chapters.

The following chapters 5.1 - 5.5 contain the necessary information for the calculation of forces and moments.

5.1 W-truss

5.2 W-truss, cantilevered

(See for example "Wood trussed rafter design, Th. Feldborg and M. Johansen , SBI rapport 118, 1981, chapter 8").

5.3 WW-truss

5.4 Parallel chord truss

5.5 Scissor truss

Literature

Design of joints with nail plates (second edition). B. Noren,
1981. STFI, Stockholm. CIB-W 18, Warsaw.

Calculation of deflections of timber trusses.
H. Riberholt, 1982.

Two models of the ridge. H. Riberholt,
February, 1982.

Distributions of forces and moments in timber trusses regarding
the deformations in the connections.
H. Riberholt, 1982.

TWO MODELS OF THE RIDGE

February 1982.

H. Riberholt

Nordic Truss Model Group

Two models of the ridge.

Figure 1 shows the truss which has been chosen for a comparison of the results from two ridge models. The support is a bit eccentric, but only 50 or 100 mm which corresponds to what often occurs.

The following parameters have been varied

Inclination 15 or 30 degrees
Support eccentricity 50 or 100 mm
Deformations in the connections

The deformations in the connections were put to either zero or values which occur close to rupture. The last mentioned values are

Heel joint: Translation parallel with the top
chord = 2 mm
Mutual rotation, opening $2 \cdot 10^{-3}$ rad
Ridge : Translation parallel with the top chord
= 0.5 mm in each chord.
Scarf b.chord: Translation = 1.0 mm

The load on the bottom chord was a uniform distributed load of 0.3 kN/m in the outer bays and 1.05 in the middle bay. On the top chord it was for symmetric snow 1.66 kN/m and for skew snow it was 1.66 kN/m on the left half of the truss and 0.53 kN/m on the right.

Table 1 gives the results. As it can be seen there are small differences in the moments in the chords, while the normal forces are almost identical. In model 2 moments occur in the diagonals which tend to reduce the moments in the top chord.

The Combined Stress Index CSI is calculated under the assumption that the truss do not buckle laterally and it is done in accordance with [Guidelines for Static Models of Trussed Rafters].

In the top chord the CSI values are relatively independent of the model, while this is not the case in the diagonals for skew

snow load. In the latter case the horizontal resultant of the tensile forces in the diagonals creates a minor moment in the diagonals. This effect gives an indication of that relatively small eccentricities in the diagonals results in considerable bending stresses.

Distribution of forces and moments in timber trusses regarding the deformations in the connections.

The forces and the moments in a wood trussed rafter is calculated by means of a frame model, see figure below. The timber is assumed linear elastic and the deformations in the connections are regarded by introducing slip between the beam elements.

Measured and calculated deflections are compared. The test results in "Wood trussed rafter design, Th. Feldborg and Marius Johansen, SBI-rapport 118, 1981, page 136, table 7.1" have been employed.

Distribution of forces and moments in timber trusses regarding the deformations in the connections.

April 1982

H. Riberholt

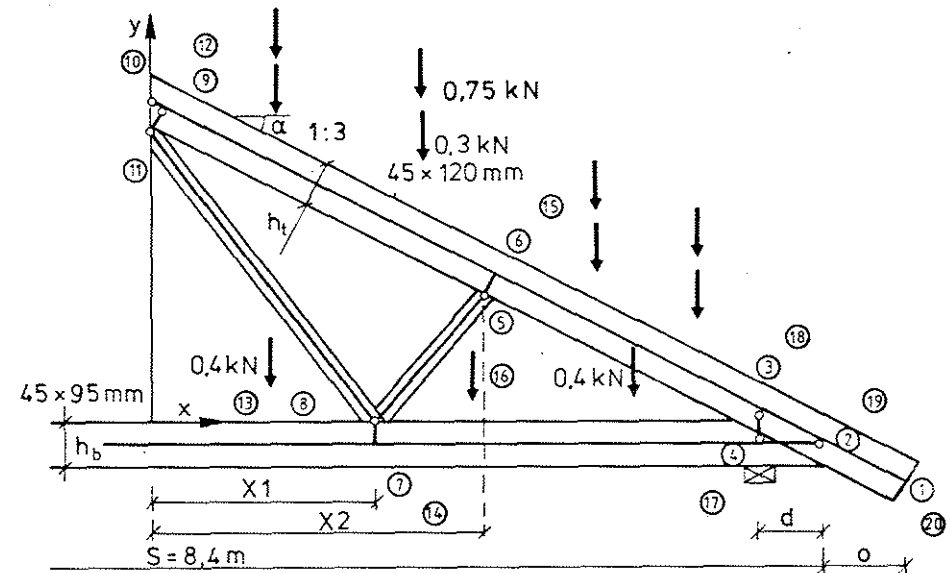

Frame model of wood trussed rafter.

By the calculation of the deflections the following assumptions have been used:

All the underlined quantities have been measured.	Measurement 3		Measurement 32	
	Short term		"Long" term	
	Dead load		Dead load + snow the 6. time	
Nail plate type	Hydro TCT		Hydro TCT	
Dimensions of chords, all	TC: 45 x 120,		BC: 45 x 95	
E-modulus. Measured from short term tests ($\frac{1}{2}$ - 1 min) $E_{mean} \sim$	10,000	10,000	8,000	8,000
13 - 14,000 MPa				
Slip at the heel joint in the direction of the top chord, mm	0.1	0.1	<u>0.8</u>	<u>1.2</u>
Relative rotation at the heel joint. Positive when the angle increases. 10^{-3} rad.	0	0	<u>1</u>	<u>1</u>
Slip at the ridge in the direction of the TC, each side, mm	0.1	0.1	0.37	0.4
Elongation at the slice in the BC, mm	0.1	0.1	0.37	0.78

Results, Deflections, mm					
Ridge	Measured	3.4	3.3	11.3	12.9
	Calculated	3.4	3.4 (3.1)	11.6	13.5
Bottom chord middle	Measured	5.5	5.4	17.9	19.5
	Calculated	6.1	6.1 (5.7)	17.3	19.2

The measured deflections indicate that the stiffness of the timber in the TCT-trusses was larger than that of the Hydro-Nail-trusses. The deflections in parantheses are calculated on the basis of an E-modulus of 11.000 MPa.

The above deflections for measurement 32 can be compared with the calculated ones when the deformations in the connections are neglected.

Ridge	7.5 mm	(measured 11.3/12.9)
Bottom chord	13.1 mm	(measured 17.9/19.5)

CONCLUSION: The deformations in the connections have a considerable influence on the deflections. With the employed method and parameters there is found a very good agreement between measured and calculated deflections.

On the next page is shown the calculated distribution of forces and moments for measurement 32, dead load + snow. Results marked H or T are valid for Hydro Nail and TCT plates respectively, and the slip in the connections are regarded. Results marked U are calculated for no slip in the connections.

In the SBI-longterm tests the deformations in the connections were less than those, which can occur when the actions are close to the rupture load of the connections. See page 40, 86 and 89 in "Wood trussed rafter design". The slip in the heal joint is typical 2-4 mm at rupture and the elongation in a splice ~ 2mm. At a load of 3/4 of the failure load the deformations of the connections in short term tests are often only 1/4 of those at failure.

In the following example there have been calculated with relatively large deformations in the connections. The example is almost the same as the one in enclosure 1 to "Calculation of Deflections in Timber Trusses". The assumptions are:

Top chord	45 x 120 mm	E = 7000 MPa
Cottom chord	45 x 95 -	-
Diagonals	45 x 70 -	-
Heel joint	Slip parallel to top chord 2 mm Rotation, increase of angle $2 \cdot 10^{-3}$ rad	
Ridge	Slip 0.5 mm in each top chord	
Slice bot.ch.	1 mm elongation	

The results are shown in the figure on page 5. This shows also the results for a truss calculation where the deformations in the connections are neglected.

H: Hydro-Nail
 T: TCT
 U: Without slip

[Moment] kNm
 [Normal force] kN

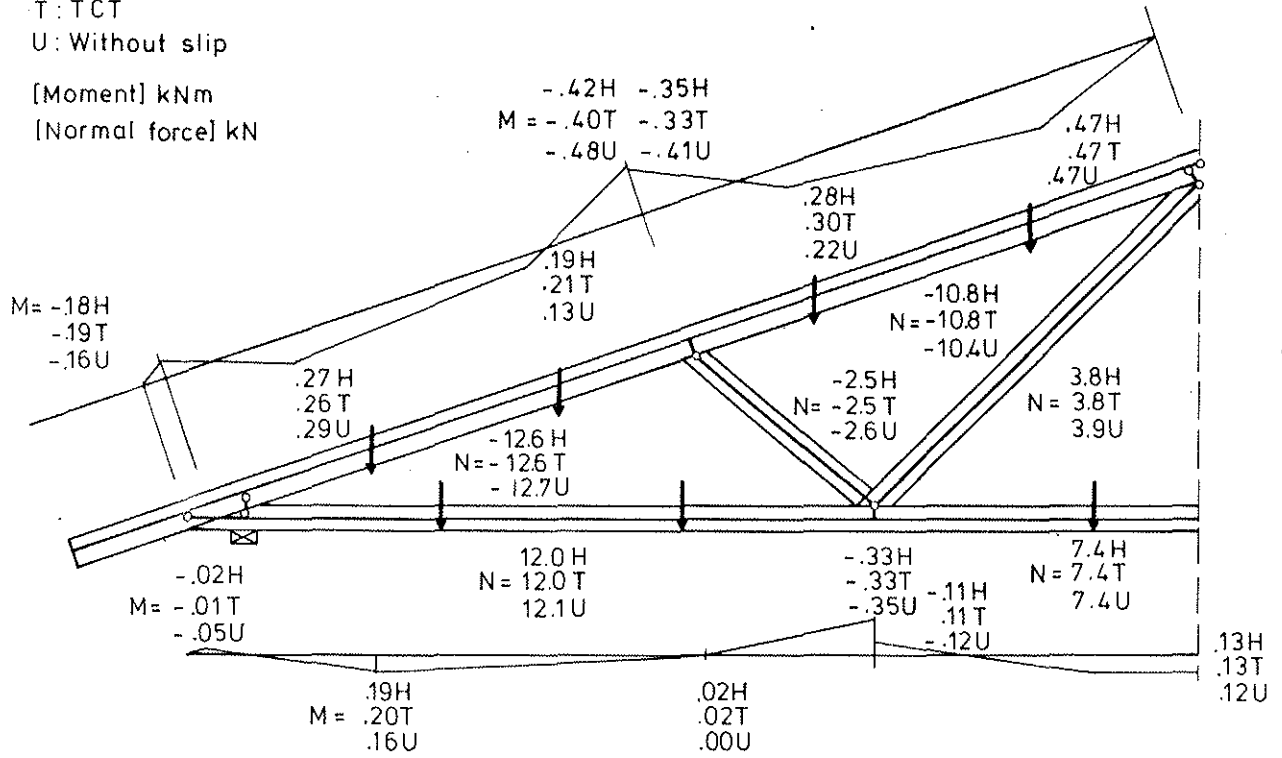

- 4 -

"Spær" 80m $\alpha = 20^\circ$

Relative large deformations in the connections.

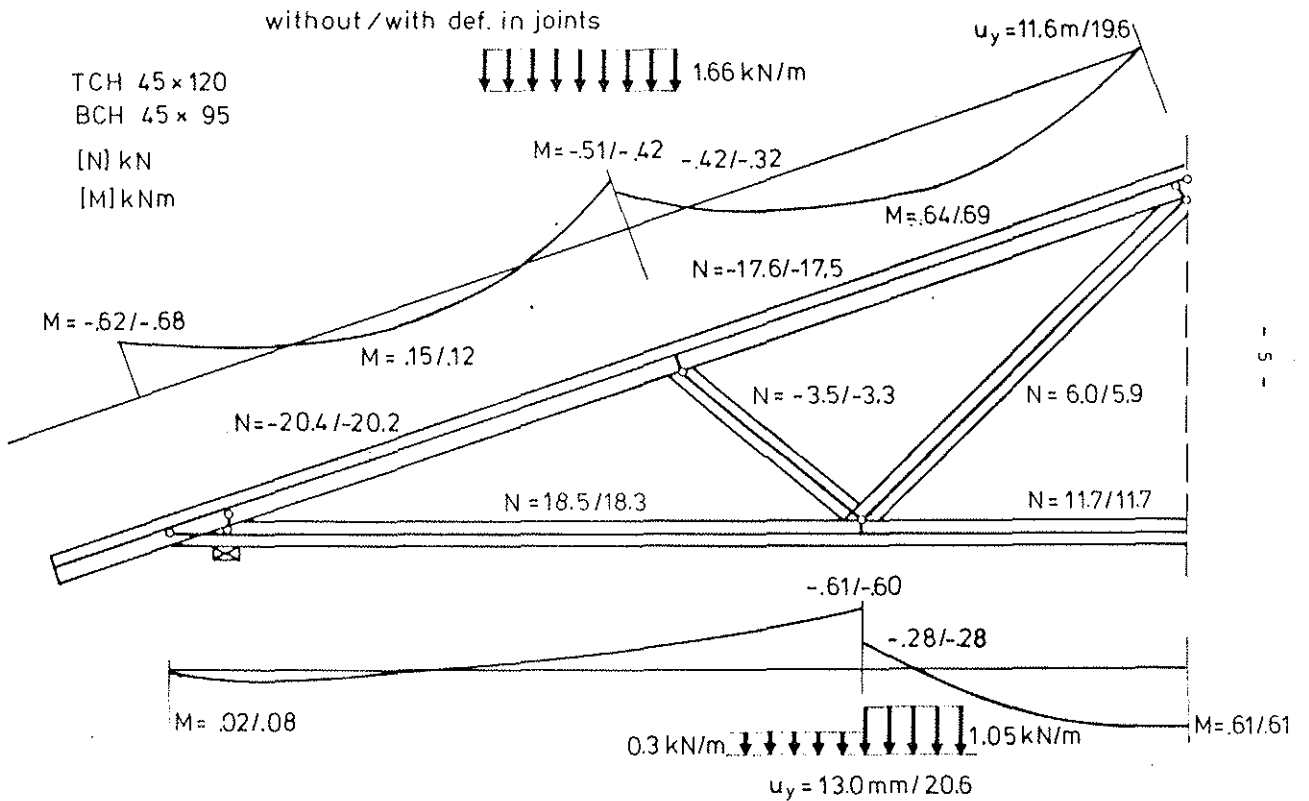

- 5 -

As expected the deformations in the connections have some influence on the moment distribution, the maximum difference is 20%. The normal forces are almost identical.

Moment coefficients.

In order to see the size of the moment coefficients these have been calculated for the truss with a span of 8.0 m. The moment coefficients are here defined so that

$$|M_{\text{frame model}}| = \text{mom. coeff.} \cdot q l_{\text{bay}}^2$$

The following moment coefficients m.c. can be derived

Top chord: $l_{\text{bay}} = 8.0/4 = 2.0 \text{ m}$, $q = 1.66 \text{ kN/m}$

lower bay : m.c. = $0.15 / (1.66 \cdot 2.0^2) = 0.022$

node at dia.: m.c. = $0.5 / (1.66 \cdot 2.0^2) = 0.075$

upper bay : m.c. = $0.69 / (1.66 \cdot 2.0^2) = 0.104$

Bottom chord: $l_{\text{bay}} = 8.0/3 = 2.67 \text{ m}$, $q = 0.3 \text{ or } 1.05 \text{ kN/m}$

outer bay : zero or ?

K-connec. : $0.6 / (1.05 \cdot 2.67^2) = 0.080$

middle bay : $0.61 / (1.05 \cdot 2.67^2) = 0.081$

In this case it would be more relevant for the bottom chord to regard the distributed load as a load combination of two cases:

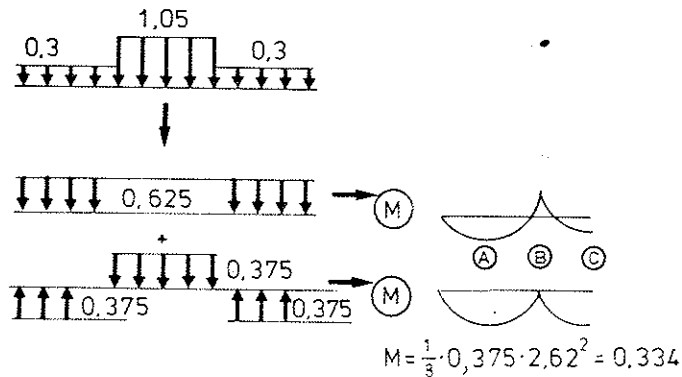

As shown in the previous figure the moments arising from the loading case with alternating sign can be found directly. By requiring moment identity in point B and C in the middle bay the following moment coefficients for the constant distributed load 0.675 kN/m can be obtained

$$B: \text{ m.c. } = \frac{1}{2}(0.60 + 0.28) / (0.675 \cdot 2.67^2) = 0.09$$

$$C: \text{ m.c. } = (0.61 - 0.334 - \frac{0.60 - 0.28}{2}) / (0.675 \cdot 2.67^2) = 0.024$$

It is here assumed that the moment $(0.60 - 0.28) = 0.32 \text{ kNm}$ due to the eccentric connected diagonals is divided equally to both sides plus it is taken into account separately. If this is not the case then the moment coefficients become

$$B: \text{ m.c. } = 0.60 / (0.675 \cdot 2.67^2) = 0.125$$

$$C: \text{ m.c. } = (0.61 - 0.334) / (0.675 \cdot 2.67^2) = 0.057$$

The previous moment coefficients are meant to be examples, and they are only valid for this example.

53
AFDELINGEN FOR BÆRENDE KONSTRUKTIONER
DANMARKS TEKNISKE HØJSKOLE

CALCULATION OF DEFLECTIONS IN TIMBER TRUSSES

April 1982

H. Riberholt

Annex 3
to CIB-W18/15-14-1

Calculation of deflection of timber trusses.

The calculation of the deflections can be done by means of the Principle of Virtual Work, PVW.

If the static model consists of beam elements and connection elements then PVW can be formulated in generalized beam strains ($\epsilon_N, \gamma(\sim 0), \kappa$), deformations in the connections (u_x, u_y, α), forces and moments in the beams (N, V, M) and in the connections (F_x, F_y, M). The symbols in the parentheses denote the quantities, which must be employed in a plane truss.

For time independent phenomena the deflection of a point in a given direction can be found from:

$$u = \sum_{\text{beams}} \left[\int_0^L (\epsilon N^1 + \kappa M^1) ds \right] + \sum_{\text{connec}} [u_x F_x^1 + u_y F_y^1 + \alpha M^1] \quad (1)$$

The summation must be carried out over all the beam elements and all the connections. The quantities $\epsilon_N, \kappa, u_x, u_y, \alpha$ are the deformations from the actions, fx:

$$\kappa = M/EI \quad (2)$$

$$u_x = F_x/K_x \quad (3)$$

where K_x is the stiffness of the connection in the x-direction for a force in the same direction.

It is not without problems to determine the stiffness of the connections, among other things due to the time dependency and nonlinearity. They can therefore only be determined with a relatively large uncertainty.

Since the connections often are designed, so that they just can take the forces, which they are subjected to, this implies that for each single connection type the deformations can be determined directly and more accurately in the serviceability limit state.

It appears likely that it is sufficient to give a set of essential deformations (u_x, u_y, α) for a given connection.

Ex. for splices:

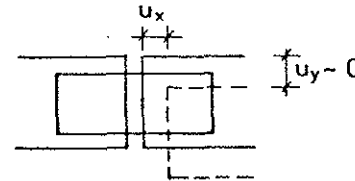

$\alpha = 0$, if the splice is positioned at a moment zero point.

The calculations would be facilitated if the deformations for one type of connections could be fixed to a few values valid for either the serviceability state or the ultimate state. In frame programs it is simple to take into account slip in the connections and in hand calculations it is done by means of the second term in Equation (1).

With reference to hand calculations it could be interesting to look into equation (1).

For normal lattice trusses the deformations in the connections have a moderate influence on the distribution of forces. It is therefore a good approximation to employ forces, calculated under the assumption of no deformations in the connections, at the calculation of the deflections. Enclosure 1 illustrate this.

The first term of (1) gives the deflection contribution from the wood:

$$u_{\text{wood}} = \sum_{\text{beams}} \left[\int_0^L (\epsilon N^1 + \kappa M^1) ds \right] \quad (4)$$

For the determination of the deflections at the connections in trusses supported just below the connections (i.e. without eccentricities) it will be valid that

$$M^1 = 0 \Rightarrow$$

$$u_{\text{wood}} = \sum_{\text{beams}} \epsilon N^1 l_{\text{beam}} \quad (5)$$

where the strains ϵ may be

N/EA from loads
 ϵ_{moist} from moisture variations

If the deflections between the connections are wanted, then $M^1 \neq 0$ so the term αM^1 cannot be neglected. This means that the deflection of the timber between the connections must be regarded.

The second term in equation (1) gives the deflection contribution from the connections. It is essential for PVW to define the forces and deformations in a consistent way. On the next page are shown the quantities for some typical connections in a truss.

The connections may be calculated linear elastic. The necessary stiffness can be derived from

$$\begin{aligned} K_x &= F_x / u_x \\ K_y &= F_y / u_y \\ K_\alpha &= M / \alpha \end{aligned} \quad (6)$$

The second term in equation (1) can thus be formulated in the following ways

Elastic connections:

$$u_{connec} = \sum_{connec} \left[\frac{F_x}{K_x} F_x^1 + \frac{F_y}{K_y} F_y^1 + \frac{M}{K_\alpha} M^1 \right] \quad (7)$$

Known deformations in the connections:

$$u_{connec} = \sum_{connec} \left[u_x F_x^1 + u_y F_y^1 + \alpha M^1 \right] \quad (8)$$

SPLICE

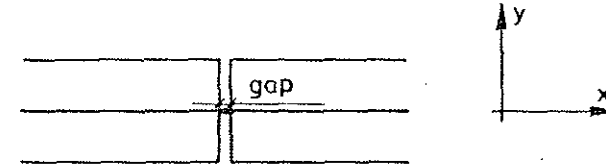

Unloaded state, the nodes of the beam elements coincide.

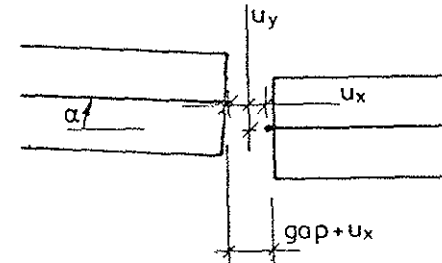

Loaded state, the nodes of the beam elements have deformed relatively to each other.

HEEL JOINT

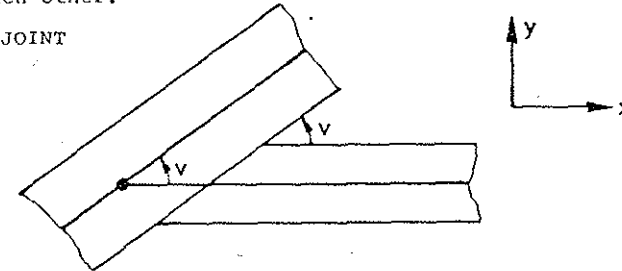

Unloaded state, the nodes of the beam elements coincide.

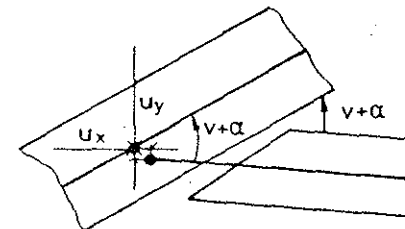

Loaded state, the nodes of the beam elements have deformed relatively to each other.

ENCLOSURE 1

CALCULATION OF DEFLECTIONS IN TIMBER TRUSSES

COMPARISON OF HANDCALCULATIONS AND FRAME CALCULATIONS

This enclosure contains an explanation of how deflections of a typical W-truss can be calculated. There is employed partly a frame model and partly a simple handcalculation method.

The timber parts are assumed linear elastic and the deformations in the connections are assumed known in advance. The loads are dead load + snow on the roof + live load on the middle bay of the bottom chord, see figure below.

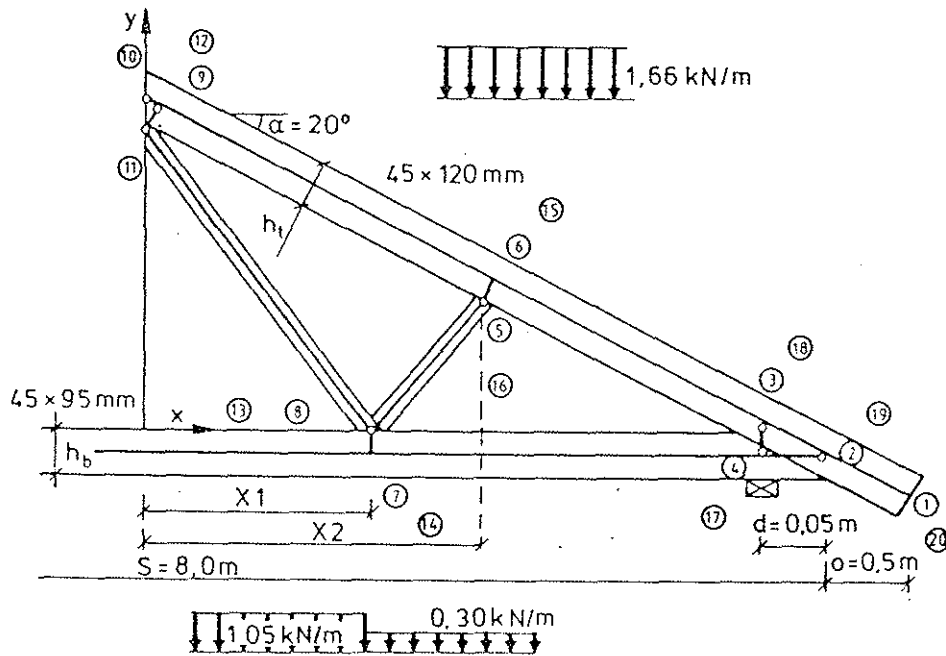

Frame Model with distributed loads.

In the following connections the deformations are regarded.

Heel joint. The deformation is assumed to consist in a translation of the top chord downwards and parallel to the top chord. Slip = 2 mm. The deformation perpendicular to the top chord and the relative rotation α are put equal to zero.

Ridge. The deformation is assumed to consist in a translation of node 9 toward node 10, $u_0 = 0.5$ mm. The other two deformations u_{90} and α are put equal to zero. The same on the other side of the ridge.

Splice in the bottom chord, middle bay. An elongation of $u_x = 0.5$ mm is assumed. u_y and α are put equal to zero.

The values of the deformations are estimated on the basis of page 140 in "Wood trussed rafter design, SBI-rapport 118, 1981, Th. Feldborg and Marius Johansen". The deformations should thus be realistic for the serviceability state.

The vertical deflections are by means of a frame program calculated to:

	K-connection in the bottom chord	Ridge
Def. in connec. = 0	13.0 mm	11.6 mm
Def. in connec. as described above.	20.3 mm	19.6 mm
Difference = u_{connec}	7.3 mm	8.0 mm

The differences in the deflections correspond to the deflection contribution from the connections.

The vertical deflections are also found by handcalculation. The contribution from the wood can be calculated from equation (4)

and that from the connections from equation (8). The virtual forces in equation (8) are found by means of a pinned-joint model and the result is given in the table below.

	K-connection in the bottom chord.	Ridge
u_{connec}	7.5 mm	7.3 mm

The result of the handcalculations are thus in reasonable good accordance with that of the frame model. The main reason for this is that the distributions of forces is relatively insensitive to the magnitude of slip in the connections, see figure on the next page.

"Spær" 8.0m $\alpha = 20^\circ$

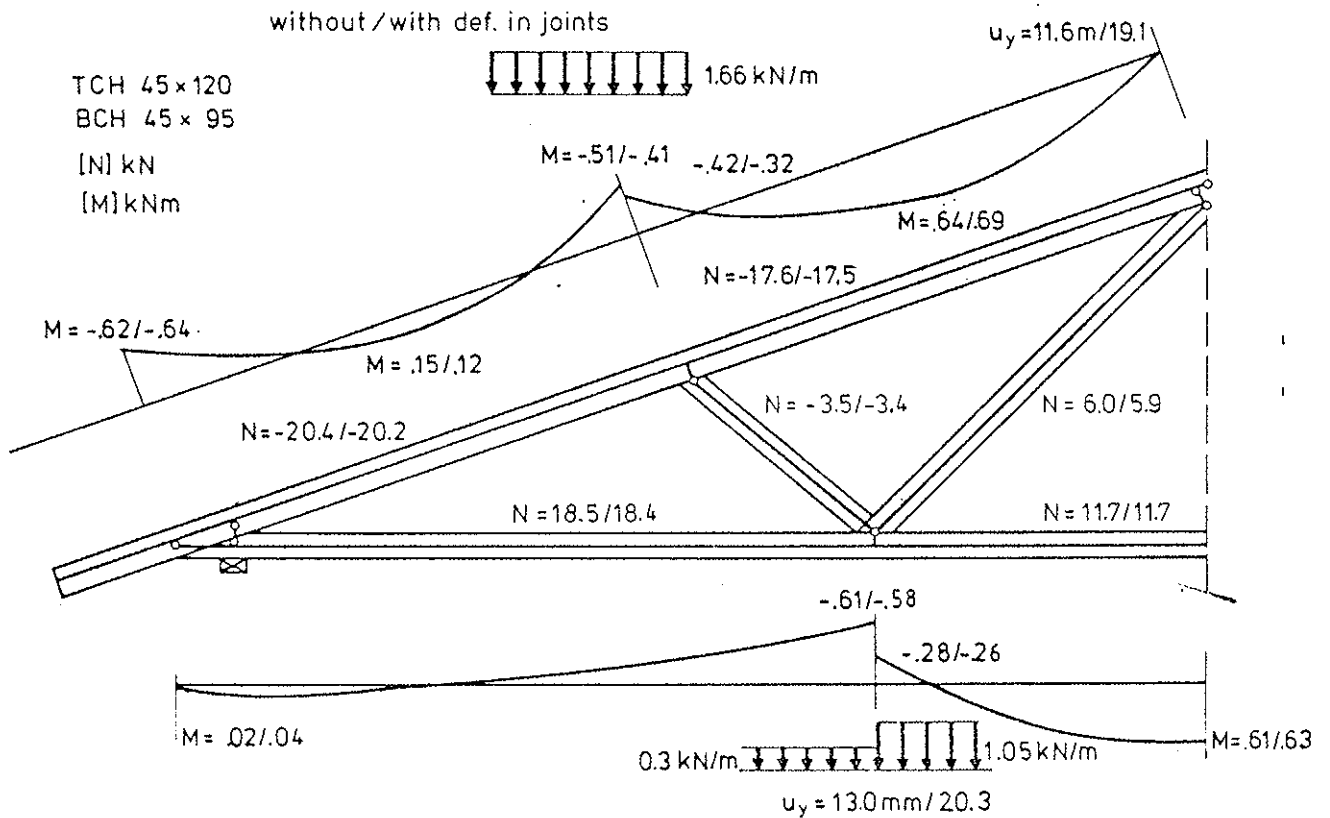

INTERNATIONAL COUNCIL FOR BUILDING RESEARCH STUDIES AND DOCUMENTATION

WORKING COMMISSION W18 - TIMBER STRUCTURES

THE INFLUENCE OF VARIOUS FACTORS ON THE
ACCURACY OF THE STRUCTURAL ANALYSIS OF TIMBER ROOF TRUSSES
by

F R P Pienaar

National Timber Research Institute
Council for Scientific and Industrial Research
Pretoria, South Africa

KARLSRUHE
FEDERAL REPUBLIC OF GERMANY

JUNE 1982

DRAFT

SPECIAL REPORT

HOUT 253 The influence of various factors
on the accuracy of the structural
analysis of timber roof trusses.

F R P Pienaar

Project Number

National Timber Research Institute
Nasionale Instituut vir Houtnavorsing

COUNCIL FOR SCIENTIFIC AND INDUSTRIAL RESEARCH
WETENSKAPLIKE EN NYWERHEIDNAVORSINGSRAAD

CSIR Special Report HOUT
UDC
ISBN

Pretoria, South Africa
April 1982

CSIR Special Report HOUT 253

UDC

ISBN

Published in April 1982 by the
Council for Scientific and Industrial Research
P O Box 395
PRETORIA
0001
South Africa

Printed in the
Republic of South Africa
by the Graphic Arts Division of the
Council for Scientific and Industrial Research
PRETORIA

2.3. Detail of roofs

The influence of joint rigidities on trusses for sheeted and tiled roofs is investigated. Full details of the roofs under investigation are as follows:

	Tiled roofs	Sheeted roofs
Dead load on rafter	510 N/m	100 N/m
Live load on rafter	500 N/m	500 N/m
Dead load on tie-beam	100 N/m	100 N/m
Truss spacing	0,750 m	1,350 m
Batten/purlin spacing	0,340 m	1,140 m

Four different roof pitches, (10° , 15° , 20° and 30°) and three different truss spans (6, 9 and 12 m) are considered. The member sizes and grades used are shown in Table 1.

2.4. Structural analysis

All the cases, except case 4, were analysed using the computer program TRUSPAC. The program takes the second order effects into account. Case 4 was analysed with the formulae shown in Appendix A, using a programmable pocket calculator.

2.5. Discussion

Tables 2 to 13 give the axial forces and bending moments for the different cases as analysed. As the axial forces or bending moments do not, on their own, give a clear indication of the total effects, the stress factors, (see Appendix B) were calculated for every case, and compared with stress factors for case 1, as set out in Table 14.

The following tendencies can be seen:

- Case 2 is always correct within 10 per cent.
- For case 3 the stress factor in the tie-beam in a sheeted roof is never out by more than 10 per cent either way. In tiled roofs, the stress factor in the tie-beam is underestimated by up to 18 per cent. For case 3, (rafter) the following tendencies are noticeable:

- at low roof pitches (10°), the stress factor is underestimated by up to 17 per cent
 - at higher pitches (greater than 15°) the stress factor is overestimated by up to 23 per cent
 - for short spans inaccuracy is greater in tiled roofs than in sheeted roofs.
- In case 4, the analysis of the tie-beam is always accurate to within 10 per cent except for 6 and 9 m span tiled roofs. In an analysis of the rafter inaccuracy of up to 30 per cent occurs. However, the inaccuracy is conservative and therefore safe. The degree of inaccuracy is very dependent on the pitch, increasing with increase in roof pitch. This indicates that there is less safety at low pitches.
 - In case 5, the stress factor in the rafter is always overestimated (i.e. conservative) but in the tie-beam, the stress factor is generally underestimated, except for low pitches. According to the results the rafter of a roof truss with one bolt and four nails in each connection, which has been analysed ignoring the axial stiffness of the joints, is unsafe.

2.6. Conclusions

W-trusses analysed with rigid joints, give reasonably accurate results, (within approximately 10 per cent). Hinged joints, with continuity of members taken into account, produce less accurate results than those for rigid joints. The method described in case 4 gives only a rough indication of the stresses. It can be unsafe to analyse a roof truss with bolt and nail connections by methods which do not take the axial stiffness of joints into account.

3. THE INFLUENCE OF THE SECOND ORDER EFFECTS ON THE ANALYSIS OF TRUSSES

3.1. Introduction

Second order effects are those caused by the axial forces in members acting on the deflected shape. The primary bending moment for the figure below is:

$$M = \frac{ql^2}{8}$$

Where q = distributed load
 l = span

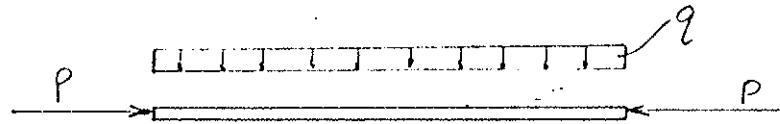

Because the beam will deflect under load, an additional bending moment is produced, namely $p \times \delta$

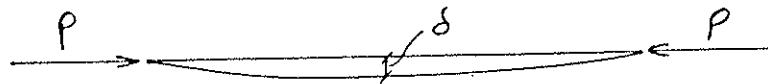

This additional bending moment is what is known as a second order effect. This effect is greater in timber structures than in reinforced concrete or steel structures because the relationship of Young's modulus to breaking strength is lower for timber than for concrete or steel.

3.2. Details of trusses

The only roof covering considered in this analysis is tiles. The roof detail is as in paragraph 2.3.

3.3. Analysis

The analysis was done with TRUSPAC. The trusses were first analysed without taking the second order effects into account, and then re-analysed taking the second order effects into account. The results are shown in Table 15.

3.4. Discussion

Because the tie-beam is in tension and the rafter in compression, it is expected that the bending moment in the tie-beam must decrease as a result of the second order effect, and that the moment in the rafter must increase. This has been found to be the case without exception with all the trusses which have been analysed, as shown in Table 15.

The influence of the second order effect increases slightly with increase in span and with decrease in roof pitch.

Table 15 shows how the maximum bending moments change. To understand the second order effects better, one has to look at the deflection of the truss (Figure 1) and the change in the bending moment diagrams, (figures 2 and 3). Only a single truss (9 m span, 15° slope), has been analysed for this purpose.

From Figure 1 it can be seen that the rafter rotates about the heel, because the ridge moves from b to c. The distance between the deflected position of the rafter and the line ac therefore gives an indication of the influence of the second order effect. In Figure 2, the bending moment in the tie-beam is shown, and in Figure 3, the bending moment in the rafter.

The following should be noted:

- The second order effect causes the moment at the heel joint to increase from 135 to 165 N-m, i.e. by 22 per cent.
- In the tie-beam the difference between the moment at the heel joint and the maximum moment is 2 N-m when second order effects are taken into account and 35 N - m when they are not. The tendency for the tie-beam "to pull straight" is thus clearly evident.
- In the rafter, the difference between the moment at the heel and the maximum moment is 497 when second order effects are considered and 439 N-m when they are not. The second order effect is also clearly evident here.

3.5. Conclusions

If the second order effect is taken into account in structural analyses, the maximum moment does not change dramatically, although the bending moment

diagrams, (especially for the tie-beam) change significantly. It is therefore usually acceptable for normal design purposes that second order effects are not taken into account. However, for research purposes, and for instances where greater accuracy is needed, second order effects must be taken into account.

4. THE INFLUENCE OF INCORRECT ASSUMPTIONS OF MEMBER SIZES ON STRUCTURAL ANALYSIS

4.1 Introduction

It is a typical engineering problem that the answer must first be known before the problem can be solved. The stiffnesses (and therefore the sizes) of all members are required for a structural analysis of any statically indeterminate structure. Member sizes must therefore be assumed, and can be refined by repetitive analysis. However, in many cases the structural analysis is not repeated and the member sizes are determined from the first analysis with assumed sizes.

4.2. Details of trusses

Trusses, as stated in paragraph 2.3. are analysed, but only for tiled roofs.

4.3. Analysis

Trusses are analysed using the member sizes as shown in Table 1.

Four new cases were then analysed:

1. Trusses with oversize top and bottom chords
2. Trusses with undersize top and bottom chords
3. Trusses with oversize top chords and undersize bottom chords.
4. Trusses with undersize top chords and oversize bottom chords.

The use of the expression 'undersize' or 'oversize' is taken to mean that the next smaller or larger standard timber size was used but that the grade was kept constant. Where the size was already the maximum and a 'larger' size is required, the grade of the timber was increased.

With the new sizes known, the axial forces and bending moments were calculated with the help of TRUSPAC, and thereafter these forces and moments and the

original sizes were used for the calculation of the stress factors.

4.4. Discussion

It is generally expected that, if the sizes of the rafters and the tie-beams change, but retain the same relationship to each other, the stress distribution between the chords will change very little. However, the results given in Table 16 show that if both the tie-beam and the rafter is chosen, a size too large or too small, the forces and moments change significantly. This is because the standard sizes do not change in the same proportion as the stresses in the chords. If the one chord is too large, and the other too small, the influence is even greater and can be as much as 73 per cent, as shown in Table 16. In general, it seems as though the effect on structural analyses of the wrong choice of size decreases with an increase in pitch.

4.5. Conclusions

The use of the wrong size members in the structural analysis has a surprisingly large effect. It is therefore recommended that if member sizes are determined in a design process, it should be established that the analysis was carried out using those sizes. If not, the analysis and design process must be repeated.

5. GENERAL CONCLUSIONS AND RECOMMENDATIONS

The influence of the following factors on the structural analysis were investigated:

- rigidity of joints
- second order effects
- incorrect assumptions of member sizes for the analysis

It is more accurate to regard joints as completely rigid than hinged, (with continuity of members taken into account), although the joint is in reality only semi-rigid. Static analyses are acceptable for standard cases, but should preferably not be used for spans over 12.m and slopes under 15° . Where axial rigidities of joints are low, (e.g. bolted joints) the influence is great and must be taken into account. This can only be done using sophisticated methods of analysis which are not always readily available.

In general, the influence of the second order effects is quite small and may be ignored in ordinary design.

Incorrect assumptions of member sizes can lead to serious errors in an analysis. It is therefore recommended that analysis be done iteratively, repeating the analysis with progressively more accurate member sizes.

It is sometimes less accurate to do a sophisticated analysis with the wrong member sizes than to do a simple static analysis.

Fig 1

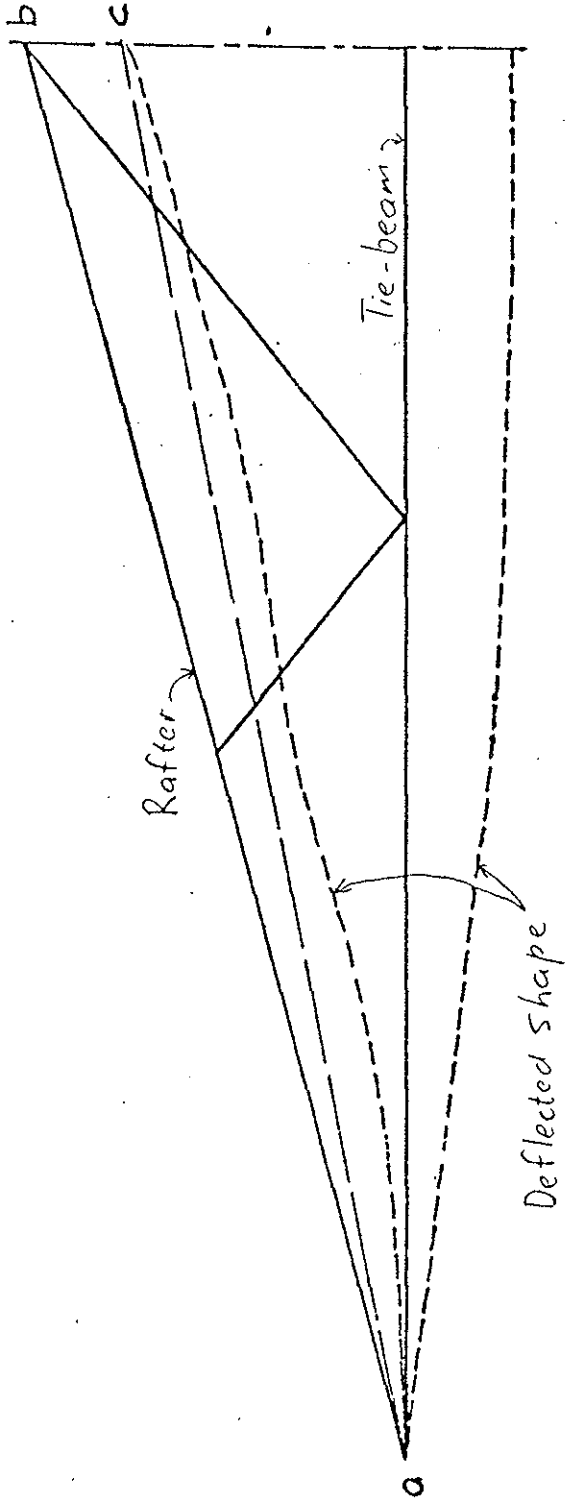

Fig 2

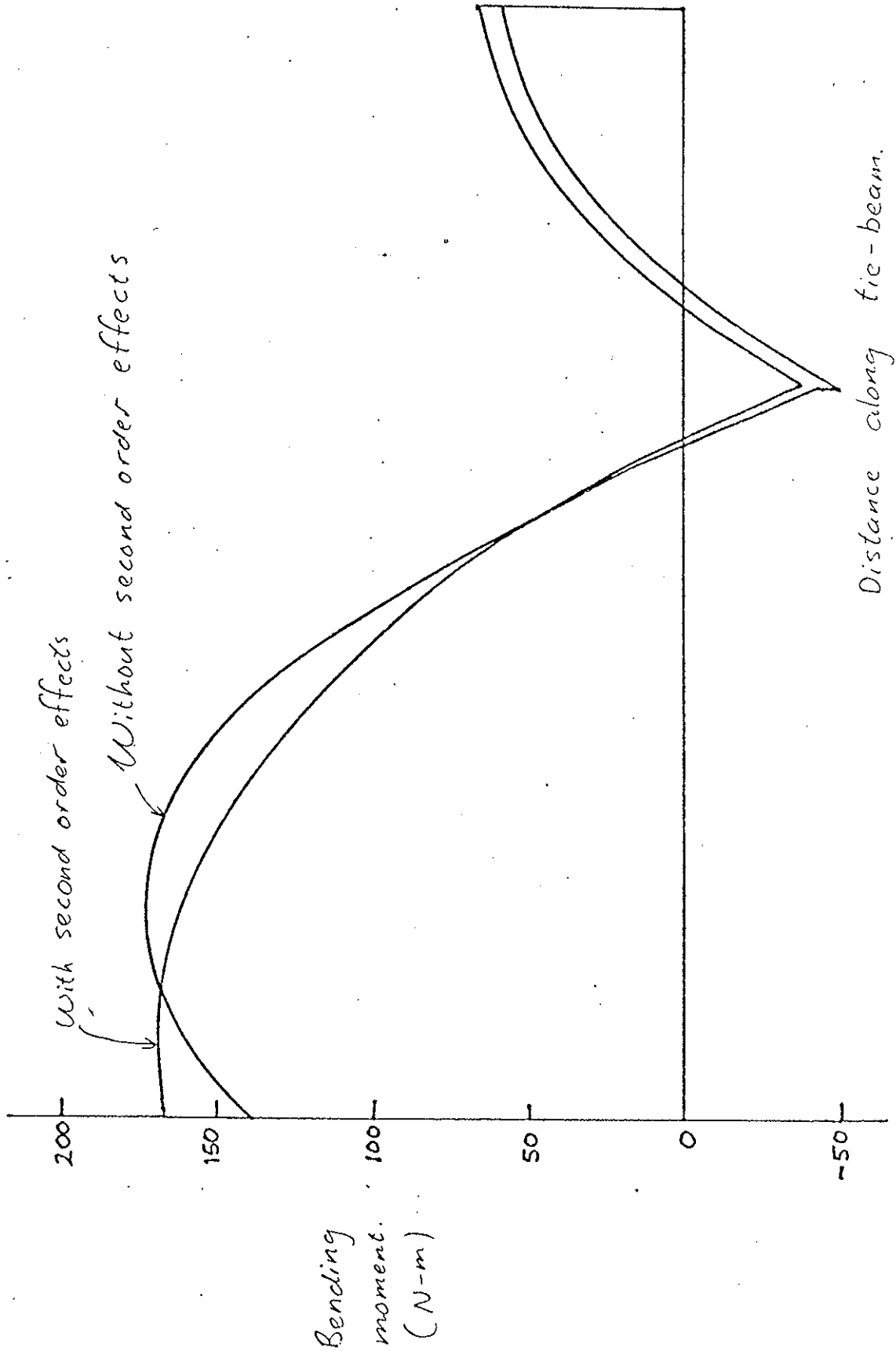
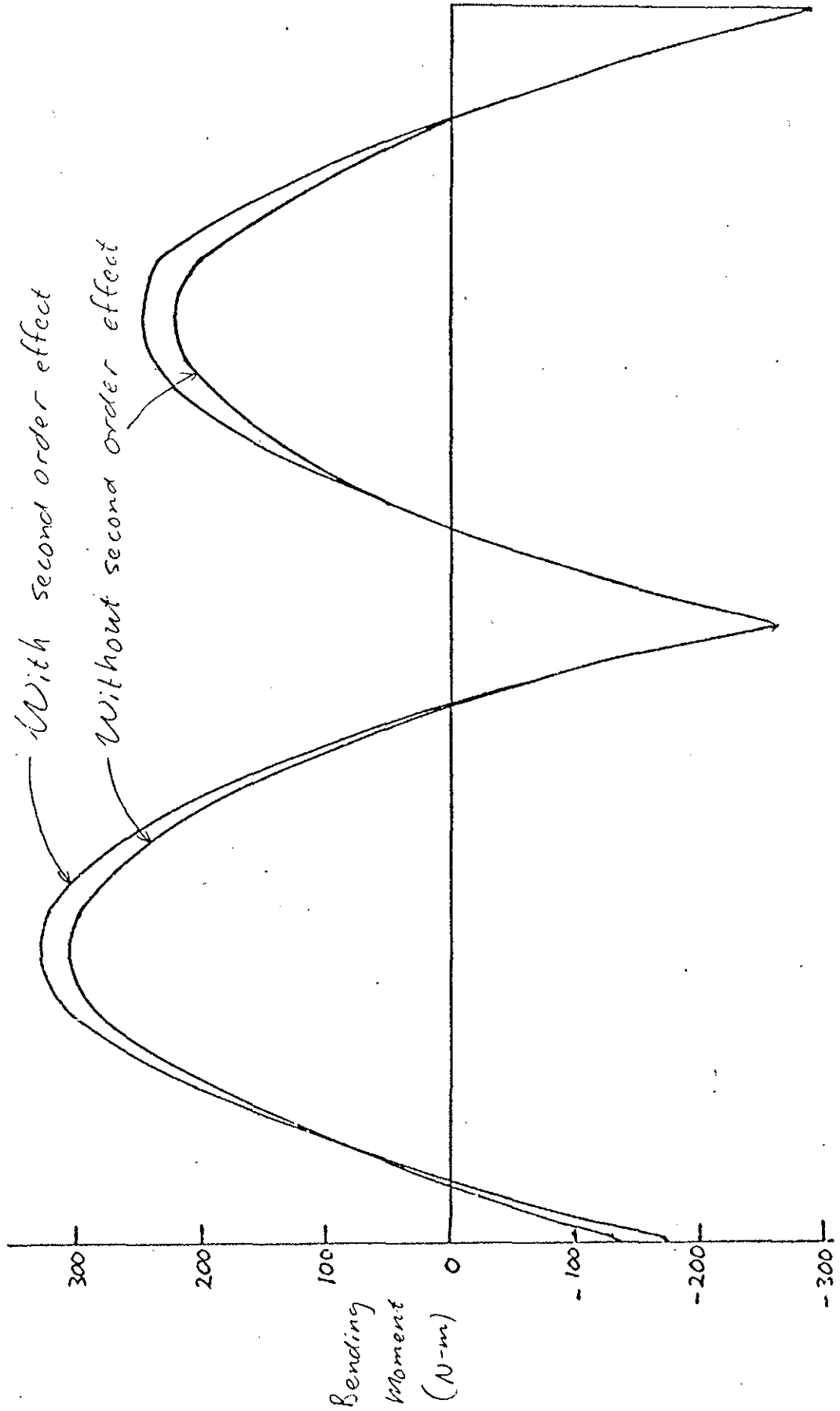

Fig 3



Distance along rafter.

TABLE 1
MEMBER SIZES

Roof covering	Span (m)	Member							
		10		15		20		30	
		BC	TC	BC	TC	BC	TC	BC	TC
Sheeting	6	111.6	149.8	111.4	111.8	111.4	111.6	73.4	111.6
	9	111.8	225.8	111.6	149.8	111.6	149.6	111.6	111.8
	12	111.8*	225.6*	111.8	225.8	111.8	225.6	111.6	149.8
Tiles	6	111.6	111.6	111.6	111.6	111.4	111.4	111.4	111.4
	9	111.8	149.8	111.8	111.8	111.6	111.8	111.6	111.8
	12	149.8	225.8	111.8	225.6	111.8	149.8	111.6	149.8

The width of members is 36 mm in all cases, but 48 mm where it is marked with a *. 111.6 Means 111 mm deep, grade 6 timber.

TABLE 2
 AXIAL FORCES AND MOMENTS (SPAN : 6m, PITCH : 10°)

Roof covering	Force or moment	Case	Member					
			1	2	3	4	5	6
Sheeting	M (N-m)	1	129	83,6	596	364	9,3	4,6
		2	106	74,8	428	326	52,98	23,2
		3	80,1	105	389	388	0,4	1,7
		4	68	68	238	238	0	0
		5	271	348	1341	1341	0,4	1,7
	F (kN)	1	10,82	8,89	11,16	10,35	0,87	1,57
		2	11,13	8,87	11,45	10,63	0,87	1,76
		3	11,52	8,32	11,84	10,45	1,48	2,14
		4	11,87	7,91	12,05	10,30	1,95	2,53
		5	6,72	7,87	7,08	7,53	0,84	0,46
Tiles	M (N-m)	1	141	90,4	318	125	2,5	5,9
		2	116	74,2	227	186	45,0	32,9
		3	79,0	116	226	223	0,4	1,7
		4	38	38	223	223	0	0
		5	327	419	652	650	0,4	1,7
	F (kN)	1	10,02	7,57	10,32	9,25	1,25	1,79
		2	10,63	7,78	10,91	9,70	1,37	1,94
		3	11,06	7,32	11,33	9,59	1,94	2,29
		4	10,52	7,01	10,68	9,04	1,82	2,14
		5	7,81	6,75	8,10	7,44	0,59	0,61

TABLE 3

AXIAL FORCES AND MOMENTS (SPAN : 9m, PITCH : 10°)

Roof covering	Force or moment	Case	Member					
			1	2	3	4	5	6
Sheeting	M (N-m)	1	130	76,5	1431	850	16,5	5,4
		2	116	73,7	1173	658	17,0	8,2
		3	127	67,6	1113	741	0,8	2,7
		4	152	152	536	536	0	0
		5	230	291	3145	3141	0,8	3,0
	F (kN)	1	17,66	14,15	18,19	16,71	1,61	2,72
		2	17,31	13,75	17,81	16,32	1,62	2,69
		3	17,45	13,19	17,96	16,17	2,00	3,13
		4	17,80	11,87	18,08	15,45	2,92	3,79
		5	11,61	12,92	12,19	12,58	1,13	0,47
Tiles	M (N-m)	1	136	71,6	741	276	1,5	7,1
		2	122	62,9	643	278	8,1	14,7
		3	89	88,4	656	320	0,8	2,7
		4	84	84	502	502	0	0
		5	296	374	1493	1223	0,8	2,9
	F (kN)	1	16,34	11,88	16,78	14,84	2,27	3,12
		2	16,22	11,69	16,65	14,65	2,32	3,10
		3	16,40	11,29	16,82	14,59	2,66	3,45
		4	15,78	10,52	16,02	13,57	2,73	3,22
		5	12,98	10,93	13,44	12,39	0,99	1,46

TABLE 4

AXIAL FORCES AND MOMENTS (SPAN : 12m, PITCH: 10°)

Roof covering	Force or moment	Case	Member					
			1	2	3	4	5	6
Sheeting	M (N-m)	1	158	147	1801	741	9,8	7,4
		2	170	152	1715	715	21,1	6,9
		3	182	182	1606	829	1,6	4,3
		4	270	270	954	954	0	0
		5	264	327	4015	3597	1,5	5,2
	F (kN)	1	25,87	18,99	26,55	23,69	3,31	4,95
		2	26,05	19,12	26,73	23,82	3,36	4,95
		3	26,19	18,50	26,87	23,70	3,76	5,49
		4	23,73	15,82	24,10	20,60	3,90	5,05
		5	20,26	18,23	21,02	20,07	0,58	1,56
Tiles	M (N-m)	1	219	124	1508	597	3,0	8,4
		2	202	127	1326	688	6,6	11,9
		3	165	161	1298	771	1,6	4,5
		4	150	150	892	892	0	0
		5	476	637	3301	3017	1,5	5,3
	F (kN)	1	22,16	16,42	22,78	20,28	2,91	4,07
		2	22,16	16,35	22,76	20,20	2,90	4,01
		3	22,44	15,67	23,02	20,06	3,46	4,56
		4	21,03	14,02	21,36	18,09	3,65	4,29
		5	16,88	15,29	17,53	16,59	0,66	1,31

TABLE 5

AXIAL FORCES AND MOMENTS : (SPAN : 6m, PITCH 15°)

Roof covering	Force or moment	Case	Member					
			1	2	3	4	5	6
Sheeting	M (N-m)	1	98,3	42,7	288	127	2,9	4,3
		2	97,3	29,6	308	126	33,6	2,3
		3	78,1	29,2	331	182	0,4	1,5
		4	68	68	252	252	0	0
		5	140	159	597	362	0,5	1,6
	F (kN)	1	7,92	5,68	8,39	7,40	1,29	1,87
		2	8,68	6,10	9,18	8,02	1,56	2,14
		3	8,70	5,99	9,19	8,06	1,69	2,31
		4	7,81	5,21	8,09	6,91	1,45	1,89
		5	7,57	5,84	8,09	7,23	1,04	1,53
Tiles	M (N-m)	1	107	43,5	226	94,0	7,1	4,2
		2	117	23,1	249	129	41,1	4,7
		3	60,4	38,5	301	202	0,4	1,4
		4	38	38	236	236	0	0
		5	178	209	494	244	0,4	1,4
	F (kN)	1	7,16	5,09	7,61	6,65	1,26	1,67
		2	7,58	5,35	8,04	6,98	1,44	1,83
		3	7,62	5,23	8,06	7,03	1,60	2,02
		4	6,92	4,61	7,17	6,07	1,36	1,60
		5	6,65	5,03	7,10	6,28	1,10	1,37

TABLE 6
 AXIAL FORCES AND MOMENTS : (SPAN : 9m, PITCH 15°)

Roof covering	Forces or moment	Case	Member					
			1	2	3	4	5	6
Sheeting	M (N-m)	1	125	89,7	624	244	7,0	2,9
		2	113	86,7	556	306	21,4	3,5
		3	110	91,5	536	312	1,0	3,3
		4	152	152	567	567	0	0
		5	162	193	1060	834	1,0	3,4
	F (kN)	1	12,61	8,74	13,31	11,64	2,22	3,10
		2	12,58	8,68	13,27	11,56	2,23	3,06
		3	12,66	8,42	13,34	11,55	2,45	3,33
		4	11,71	7,81	12,13	10,37	2,18	2,83
		5	11,10	8,31	11,83	10,51	1,53	2,29
Tiles	M (N-m)	1	170	53,3	436	285	19,4	2,8
		2	166	52,0	418	298	41,9	3,7
		3	79,8	55,7	486	422	1,0	3,3
		4	84	84	531	531	0	0
		5	160	228	710	445	1,0	3,4
	F (kN)	1	11,30	7,70	11,93	10,31	2,13	2,75
		2	11,38	7,72	12,02	10,33	2,17	2,75
		3	11,49	7,49	12,11	10,35	2,44	3,02
		4	10,38	6,92	10,75	9,10	2,04	2,40
		5	10,69	7,35	11,32	9,76	2,04	2,52

TABLE 7
AXIAL FORCES AND MOMENTS : (SPAN : 12m, PITCH 15°)

Roof covering	Force or moment	Case	Member					
			1	2	3	4	5	6
Sheeting	M (N-m)	1	190	179	1300	559	7,5	3,7
		2	193	173	1165	690	16,2	5,2
		3	206	206	1046	692	2,0	5,1
		4	270	270	1009	1009	0	0
		5	188	185	2353	2043	1,9	5,7
	F (kN)	1	17,31	12,03	18,27	15,97	3,04	4,19
		2	17,07	11,94	18,01	15,74	2,91	4,00
		3	17,18	11,53	18,12	15,71	3,22	4,40
		4	15,62	10,41	16,17	13,82	2,91	3,77
		5	14,60	11,46	15,66	4,07	1,59	2,66
Tiles	M (N-m)	1	115	104	1129	457	10,4	4,7
		2	110	98,3	978	624	11,0	6,6
		3	106	106	907	623	1,97	5,2
		4	150	150	943	943	0	0
		5	132	172	1895	1624	1,9	5,8
	F (kN)	1	15,69	10,89	16,57	14,38	2,90	3,68
		2	15,29	10,62	16,14	13,98	2,77	3,49
		3	15,43	10,23	16,28	13,94	3,11	3,87
		4	13,84	9,23	14,33	12,13	2,72	3,20
		5	13,35	10,16	14,26	12,62	1,80	2,47

TABLE 8
AXIAL FORCES AND MOMENTS : (SPAN : 6m, PITCH 20°)

Roof covering	Force or moment	Case	Member					
			1	2	3	4	5	6
Sheeting	M (N-m)	1	91,4	31,1	226	102	8,2	2,6
		2	94,5	39,99	243	154	37,9	1,8
		3	70,9	40,9	269	217	0,6	1,9
		4	68	68	273	273	0	0
		5	109	107	416	234	0,6	1,9
	F (kN)	1	6,11	4,21	6,73	5,87	1,28	1,79
		2	6,51	4,47	7,16	6,21	1,42	1,92
		3	6,53	4,37	7,17	6,26	1,57	2,09
		4	5,75	3,83	6,12	5,23	1,24	1,60
		5	5,99	4,30	6,65	5,84	1,26	1,67
Tiles	M (N-m)	1	87,9	23,4	190	111	10,1	2,7
		2	99,4	20,4	212	147	41,5	1,7
		3	48,7	25,7	256	221	0,6	1,9
		4	38	38	255	255	0	0
		5	88,9	105	354	175	0,6	1,9
	F (kN)	1	5,57	3,83	6,15	5,32	1,24	1,58
		2	5,90	4,05	6,52	5,60	1,34	1,69
		3	5,93	3,95	6,52	5,65	1,52	1,86
		4	5,10	3,40	5,42	4,59	1,16	1,36
		5	5,55	3,88	6,15	5,34	1,28	1,57

TABLE 9

AXIAL FORCES AND MOMENTS : (SPAN : 9m, PITCH 20°)

Roof covering	Force or moment	Case	Member					
			1	2	3	4	5	6
Sheeting	M (N-m)	1	127	106	508	320	13,6	2,7
		2	132	101	468	322	29,97	3,8
		3	110	107	458	415	1,3	3,9
		4	152	152	613	613	0	0
		5	142	134	728	550	1,3	4,0
	F (kN)	1	9,58	6,44	10,51	9,13	2,11	2,85
		2	9,54	6,44	10,46	9,06	2,06	2,77
		3	9,60	6,25	10,51	9,09	2,27	3,01
		4	8,62	5,75	9,18	7,85	1,85	2,40
		5	8,92	6,19	9,86	8,59	1,80	2,49
Tiles	M (N-m)	1	137	71,4	399	332	19,5	3,9
		2	135	66,1	385	336	41,4	5,9
		3	71,1	55,9	455	455	1,3	3,9
		4	84	84	574	574	0	0
		5	103	122	567	382	1,3	4,0
	F (kN)	1	8,60	5,77	9,45	8,14	1,95	2,47
		2	8,64	5,79	9,50	8,15	1,96	2,45
		3	8,72	5,16	9,55	8,18	2,21	2,67
		4	7,64	5,10	8,13	6,89	1,73	2,04
		5	8,35	5,56	9,19	7,90	1,98	2,41

TABLE 10
AXIAL FORCES AND MOMENTS (SPAN : 12, PITCH 20°)

Roof covering	Force or moment	Case	Member					
			1	2	3	4	5	6
Sheeting	M (N-m)	1	211	196	1047	539	12,5	6,7
		2	215	188	968	641	21,8	6,7
		3	220	220	860	640	2,5	5,7
		4	270	270	1090	1090	0	0
		5	184	139	1543	1272	2,4	6,1
	F (kN)	1	13,11	8,82	14,38	12,48	2,92	3,88
		2	12,97	8,81	14,21	12,33	2,77	3,70
		3	13,05	8,53	13,29	12,35	3,03	4,02
		4	11,50	7,67	12,24	10,46	2,47	3,20
		5	11,89	8,49	13,20	11,54	2,18	3,13
Tiles	M (N-m)	1	155	128	779	644	33,6	7,4
		2	166	123	739	630	39,1	9,8
		3	121	121	794	794	2,4	5,9
		4	150	150	1020	1020	0	0
		5	123	129	991	738	2,4	6,0
	F (kN)	1	11,74	7,82	12,88	11,07	2,72	3,37
		2	11,69	7,78	12,81	10,99	2,68	3,31
		3	11,78	7,54	12,89	11,02	2,97	3,60
		4	10,19	6,79	10,84	9,18	2,31	2,72
		5	11,31	7,51	12,44	10,68	2,65	3,25

TABLE 11

AXIAL FORCES AND MOMENTS (SPAN : 6m, PITCH 30°)

Roof covering	Force or moment	Case	Member					
			1	2	3	4	5	6
Sheeting	M (N-m)	1	55,3	46,8	214	161	9,9	2,1
		2	71,8	43,4	235	185	34,1	3,5
		3	58,3	58,3	228	228	0,8	2,6
		4	68	68	338	338	0	0
		5	53,5	45,4	306	188	0,8	2,7
	F (kN)	1	4,12	2,72	5,04	4,40	1,29	1,68
		2	4,21	2,82	5,17	4,48	1,32	1,72
		3	4,21	2,76	5,16	4,54	1,43	1,85
		4	3,62	2,42	4,19	3,58	1,05	1,36
		5	4,03	2,75	5,00	4,37	1,24	1,65
Tiles	M (N-m)	1	77,4	28,0	168	148	12,5	2,0
		2	83,9	29,1	184	154	29,4	2,98
		3	39,1	22,8	222	222	0,8	2,6
		4	38	38	316	316	0	0
		5	59,2	61,9	251	164	0,8	2,7
	F (kN)	1	3,78	2,54	4,67	4,04	1,18	1,48
		2	3,85	2,59	4,75	4,09	1,19	1,49
		3	3,88	2,50	4,76	4,15	1,38	1,65
		4	3,21	2,14	3,71	3,14	0,98	1,16
		5	3,72	2,48	4,61	3,99	1,24	1,48

TABLE 12
AXIAL FORCES AND MOMENTS (SPAN : 9m, PITCH 30°)

Roof covering	Force or moment	Case	Member					
			1	2	3	4	5	6
Sheeting	M (N-m)	1	153	128	425	407	19,2	6,7
		2	173	127	432	391	40,3	11,1
		3	124	124	516	516	1,9	5,0
		4	152	152	761	761	0	0
		5	127	86,9	483	377	1,9	5,0
	F (kN)	1	6,19	4,08	7,58	6,62	1,88	2,54
		2	6,27	4,15	7,67	6,67	1,84	2,50
		3	6,32	4,02	7,69	6,75	2,09	2,7
		4	5,436	3,62	6,29	5,37	1,58	2,05
		5	6,18	4,01	7,56	6,61	1,97	2,58
Tiles	M (N-m)	1	135	83,7	407	385	21,7	5,99
		2	139	79,5	414	377	37,7	10,0
		3	69,3	69,3	503	503	1,8	5,0
		4	84	84	712	712	0	0
		5	85,5	71,3	469	353	1,8	5,1
	F (kN)	1	5,76	3,82	7,08	6,14	1,81	2,26
		2	5,77	3,83	7,10	6,13	1,79	2,24
		3	5,83	3,71	7,12	6,21	2,04	2,45
		4	4,82	3,21	5,56	4,71	1,48	1,74
		5	5,70	3,70	7,00	6,08	1,93	2,32

TABLE 13
AXIAL FORCES AND MOMENTS (SPAN : 12m, PITCH 30°)

Roof covering	Force or moment	Case	Member					
			1	2	3	4	5	6
Sheeting	M (N-m)	1	248	220	796	761	35,2	11,9
		2	262	212	778	737	41,4	15,3
		3	231	231	893	893	3,7	6,4
		4	270	270	1353	1353	0	0
		5	195	195	855	686	3,6	6,5
	F (kN)	1	8,41	5,52	10,26	8,96	2,59	3,42
		2	8,37	5,52	10,22	8,91	2,53	3,36
		3	8,43	5,36	10,26	8,99	2,78	3,61
		4	7,25	4,83	8,37	7,16	2,10	2,73
		5	8,25	5,35	10,09	8,83	2,61	3,44
Tiles	M (N-m)	1	164	139	766	732	34,0	10,7
		2	177	133	751	714	37,0	13,8
		3	136	136	882	882	3,7	6,7
		4	150	150	1265	1265	0	0
		5	110	103	824	661	3,6	6,9
	F (kN)	1	7,82	5,15	9,59	8,31	2,51	3,06
		2	7,79	5,14	9,55	8,26	2,46	3,01
		3	7,86	4,98	9,59	8,35	2,75	3,28
		4	6,42	4,28	7,42	6,28	1,97	2,31
		5	7,69	4,97	9,44	8,19	2,58	3,11

TABLE 14

PERCENTAGE DEVIATIONS IN STRESS FACTOR FROM THE STANDARD CASE

Roof Pitch	Span (m)	Pitch (°)	Case							
			2		3		4		5	
			BC*	TC**	BC	TC	BC	TC	BC	TC
Sheeting	6	10	-3	-13	-6	-15	-7	-27	30	48
		15	7	8	2	12	9	8	8	49
		20	6	7	-2	13	-12	6	5	40
		30	13	7	3	5	1	24	-3	23
	9	10	-4	-10	-1	-12	4	-32	6	45
		15	-3	-5	-3	-7	0	-9	-1	28
		20	1	-4	-4	-5	-1	4	-1	19
		30	7	1	-8	13	-7	40	-8	8
	12	10	2	-3	4	-7	-36	-36	-4	81
		15	-1	-6	2	-10	6	-17	-11	32
		20	0	-4	1	-13	3	-5	-11	20
		30	3	-2	-3	7	-2	35	-12	4
Tiles	6	10	-2	-18	-7	-17	-20	-20	42	66
		15	7	9	-10	25	-24	1	18	79
		20	8	10	-10	25	-24	19	0	55
		30	4	7	-17	23	-29	56	-10	35
	9	10	-3	-9	-8	-7	-12	-22	17	58
		15	0	-3	-18	9	-24	13	-6	43
		20	0	-2	-16	11	-21	29	-11	31
		30	1	1	-21	19	-26	55	-17	12
	12	10	-2	-8	-4	-9	-11	-30	7	75
		15	-3	-10	-3	-15	-2	-16	-8	44
		20	2	-4	-7	1	-10	19	-9	20
		30	3	-2	-7	6	-14	48	-15	6

* BC = Tie-beam (Bottom chord)

** TC = Rafter (Top chord)

TABLE 15

MAXIMUM BENDING MOMENTS (N-m) WITH AND WITHOUT SECOND ORDER
EFFECT TAKEN INTO ACCOUNT

Pitch (°)	SPAN (m)											
	6				9				12			
	BC		TC		BC		TC		BC		TC	
	Without	With	Without	With	Without	With	Without	With	Without	With	Without	With
10°	164	158	290	308	195	176	655	698	325	279	1398	1472
15°	122	119	216	225	170	167	304	332	160	126	1052	1094
20°	97	94	180	189	158	155	339	377	161	136	932	962
30°	81	79	167	168	146	144	428	436	162	146	808	821

PERCENTAGE CHANGE IN MAXIMUM BENDING MOMENT
AS A RESULT OF SECOND ORDER EFFECT

PITCH	SPAN					
	6 m		9 m		12 m	
	BC	TC	BC	TC	BC	TC
10°	-4	6	-10	7	-14	5
15°	-2	4	-2	9	-21	4
20°	-3	5	-2	11	-16	3
30°	-2	1	-1	2	-10	2

TABEL 16

PERCENTAGE DEVIATION IN STRESS FACTOR OF WRONG ASSUMPTION OF CHORD
SIZES FOR STRUCTURAL ANALYSIS

Span (m)	Pitch (°)	BC				TC			
		Case				Case			
		1	2	3	4	1	2	3	4
6	10	12	- 4	33	-26	42	25	- 2	73
	15	10	- 4	33	-27	15	10	- 7	37
	20	8	- 4	34	-24	10	13	- 5	29
	30	1	- 5	37	-26	8	11	- 2	24
9	10	5	-11	40	-22	26	3	-17	50
	15	9	- 3	43	-24	0	17	26	19
	20	8	- 4	51	-18	0	35	4	17
	30	8	- 2	65	-19	- 8	13	- 5	7
12	10	37	- 3	56	-13	-11	- 3	-22	5
	15	15	7	47	0	- 3	- 3	-18	8
	20	4	3	61	- 8	8	18	- 8	19
	30	- 3	1	55	-10	2	8	- 6	10

- Case 1 : TC too big
- : BC too big
- 2 : TC and BC too small
- 3 : TC too big
- : BC too small
- 4 : TC too small
- : BC too big

"Too big" or "too small" means the following standard measurement in sawn wood, but the grade of the wood is kept constant.

APPENDIX A

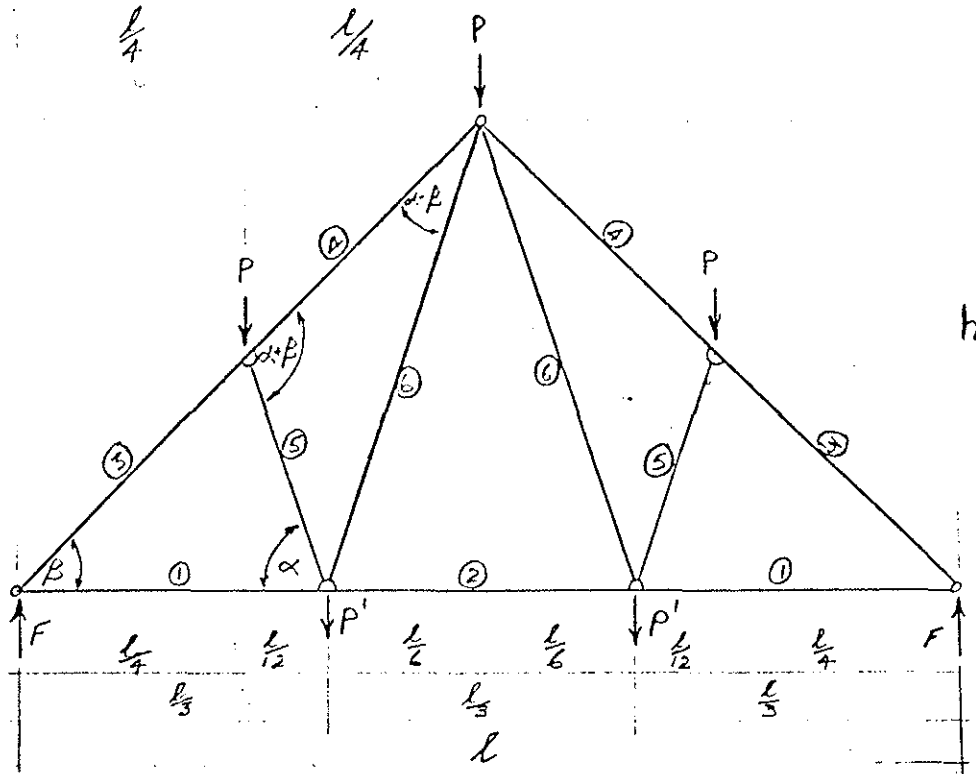

$$\alpha = \tan^{-1} (3 \tan \beta)$$

$$h = \frac{l}{2} \tan \beta$$

$$P = w \frac{l}{4} \text{ where } w = \text{roof load per unit length (N/m)}$$

$$P' = w' \frac{l}{3} \text{ where } w' = \text{ceiling load per unit length (N/m)}$$

$$F = \frac{3}{2} P + P' = \frac{3}{2} \frac{wl}{4} + \frac{wl}{3} = \frac{3}{8} wl + \frac{w'l}{3}$$

F_i = Axial force in member in i^{th} member (Tension is positive)

$$F_1 = \frac{F}{\tan \beta}$$

$$F_3 = \frac{-F}{\sin \beta}$$

$$F_5 = \frac{-P \cos \beta}{\sin(\alpha + \beta)}$$

$$F_4 = F_3 - F_5 \frac{\cos \alpha}{\cos \beta}$$

$$F_6 = \frac{P'}{\sin \alpha} - F_5$$

$$F_2 = F_1 + (F_5 - F_6) \cos \alpha$$

After the axial forces have been determined, the following model is used for the calculation of the bending moments:

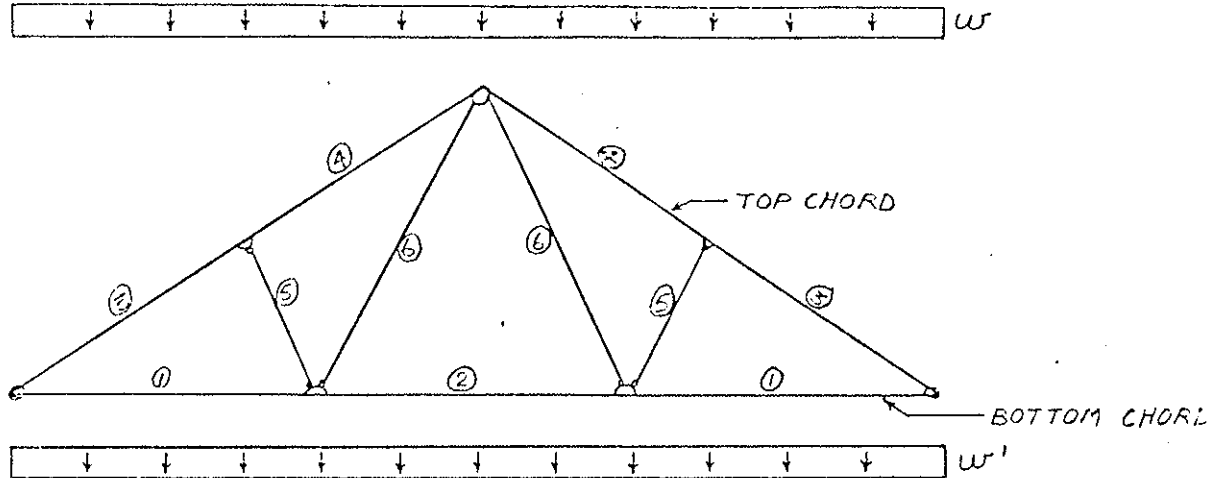

In members 5 and 6 there are therefore no bending moments.

For the tie-beam:

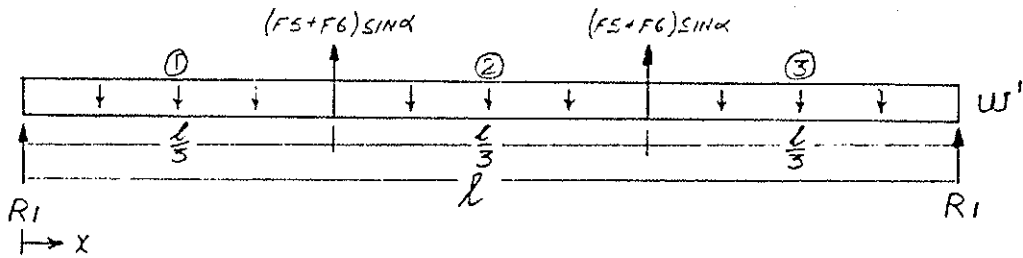

$$R_1 = w' \frac{l}{2} - (F_5 + F_6) \sin \alpha$$

For member 1: $M_1 = R_1 x - \frac{w' x^2}{2}$

$$\frac{\delta M_1}{\delta x} = R_1 - w' x = 0 \quad x = \frac{R_1}{w'} \quad \text{for } M_1 \text{ a maximum of } x = \frac{l}{3}$$

For member 2:

$$M_2 = R x + (F_5 + F_6) \sin \alpha \left(x - \frac{\ell}{3}\right) - \frac{w' x^2}{2} = \frac{w'}{2} (lx - x^2) - (F_5 + F_6) \frac{\ell}{3} \sin \alpha$$

$$\frac{\partial M_2}{\partial x} = R_1 + (F_5 + F_6) \sin \alpha - w' x = 0$$

$$x = (R_1 + (F_5 + F_6) \sin \alpha) / w' = \frac{\ell}{2} \text{ for } M_2 \text{ a maximum of } x = \frac{\ell}{3}$$

$$M_2 = 0 \text{ for } x = \frac{\ell}{2} \text{ or } M_2 = \frac{w' \ell}{72} \text{ for } x = \frac{\ell}{3}$$

For the rafter : $F_5 \sin (\alpha + \beta)$

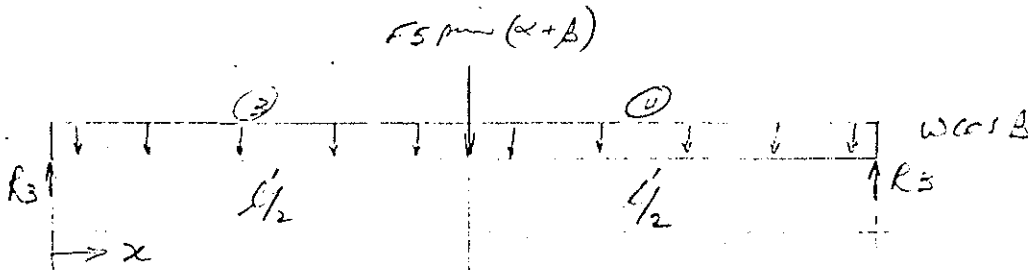

$$l' = \frac{l}{2 \cos \beta}$$

The maximum bending moment for members 3 and 4 are the same.

$$R_3 = \frac{w \cos \beta l'}{2} + \frac{F_5 \sin (\alpha + \beta)}{2}$$

$$= \frac{wl}{4} - \frac{P \cos \beta}{2}$$

$$M_3 = R_3 x - \frac{w \cos \beta x^2}{2}$$

$$\frac{\partial M_3}{\partial x} = R_3 - w \cos \beta x \quad x = \frac{R_3}{w \cos \beta} \text{ of } x = \frac{l'}{2} = 4 \frac{\ell}{\cos \beta}, \text{ for } M_3 \text{ a maximum.}$$

APPENDIX B

Stress factor = Stress factor as a result of bending + stress factor as
a result of axial force.

$$= \frac{\sigma_b}{f_b} + \frac{\sigma_a}{f_a}$$
$$= \frac{6M}{bd^2 f_b} + \frac{F}{bdf_a}$$

- where :
- σ_b : calculated bending stress
 - σ_a : calculated axial stress
 - f_b : permissible bending stress
 - f_a : permissible axial stress
 - M : bending moment
 - F : axial force.
 - b : width of member
 - d : depth

INTERNATIONAL COUNCIL FOR BUILDING RESEARCH STUDIES AND DOCUMENTATION

WORKING COMMISSION W18 - TIMBER STRUCTURES

BRACING CALCULATIONS
FOR TRUSSED RAFTER ROOFS

by

H J Burgess

Timber Research and Development Association
United Kingdom

KARLSRUHE
FEDERAL REPUBLIC OF GERMANY

JUNE 1982

CONTENTS

	Page No.
INTRODUCTION	1
Rafter buckling modes	5
Most likely buckling mode	6
TYPE OF BRACING	7
BRACING CALCULATIONS	9
REMEDIAL BRACING OF FIRST MODE BUCKLING	10
Application of column design formula	13
Limitation of lateral deflection	16
Restraint load for zero initial curvature	18
Foundation modulus from tests	20
Bracing for a set of trussed rafters	21
Design of bracing	21
SECOND MODE BUCKLING OF A ROOF WITH INADEQUATELY FASTENED DIAGONAL BRACES	26
Allowance for nail slip	28
DESIGN FOR ADEQUATE BRACING OF NEW ROOFS	32
DESIGN CALCULATIONS FOR RAFTER BUCKLING IN FOUR HALF-WAVES IN THE HALF ROOF	38
Calculation with no lateral buckling	41
COMBINATION OF WIND LOAD WITH BRACING FORCES	43
Calculation of wind load	43
Long term load plus wind	45
Medium term load plus wind	46
Conclusions	47
FURTHER CONSIDERATION OF WIND LOAD EFFECT	48

BRACING CALCULATIONS
FOR TRUSSED RAFTER ROOFS

by H.J. Burgess

Trussed rafters are really trusses at close spacing introduced because rafters are needed at close spacing to support tiles and a number of advantages are obtained by making each pair of rafters into a truss instead of using stronger trusses at wider intervals. They give an economical means of roof framing, using standard components produced by an efficient factory process, and can be easily handled and erected rapidly on site. If incorporated correctly in the building they provide a structure designed by engineering calculations or proved by test in conformity with established codes of practice. The calculations and the method of test assume that when trussed rafters are installed in a roof they will be supported against movement in their weaker direction. For domestic buildings of normal size, the lateral restraint is provided by diagonal braces to which the forces supporting the rafter are transmitted by the tiling battens.

To ensure correct use of the components, the International Truss Plate Association has issued a bulletin showing the necessary type of diagonal bracing illustrated in Fig.1 and giving details of how it is to be attached. A firm joint is also required where the diagonal braces meet the wall plate (Fig.2) and a revised British Code of Practice will require bracing in the ceiling plane (Fig.3) which will reduce the gable end wind loading to be resisted by bracing in the rafter planes.

Efforts have been made to ensure that the rafter bracing is correctly applied on site but despite the precautions, the importance of careful installation of the trusses and correct bracing by diagonals underneath the rafters is often not realised. Some of the earlier trussed rafters erected without diagonal bracing are now deflecting in a direction parallel to the ridge, a condition known as 'lateral buckling' which occurs because the slender rafters need to be restrained against this type of deflection. The defect appears in varying degrees in a set of identical roofs, and may occur so slowly that the worse cases are not noticed until after ten years or more while the less severe cases may give the impression that the trussed rafters were originally erected out-of-plumb. Large deflections usually require replacement of the entire roof structure, and even if the deflection is small the work of installing bracing to prevent further deflection can be difficult and costly.

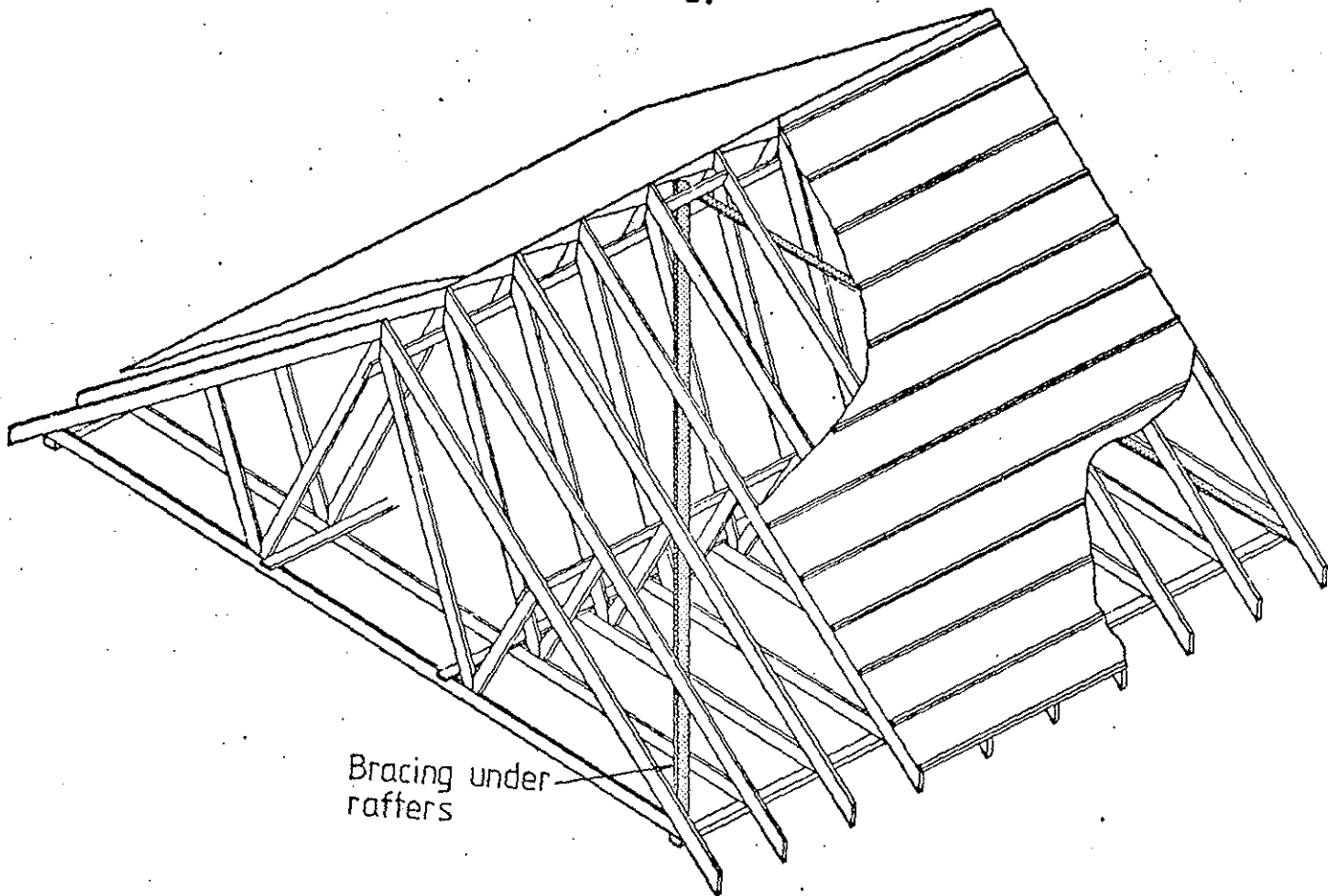

FIG. 1

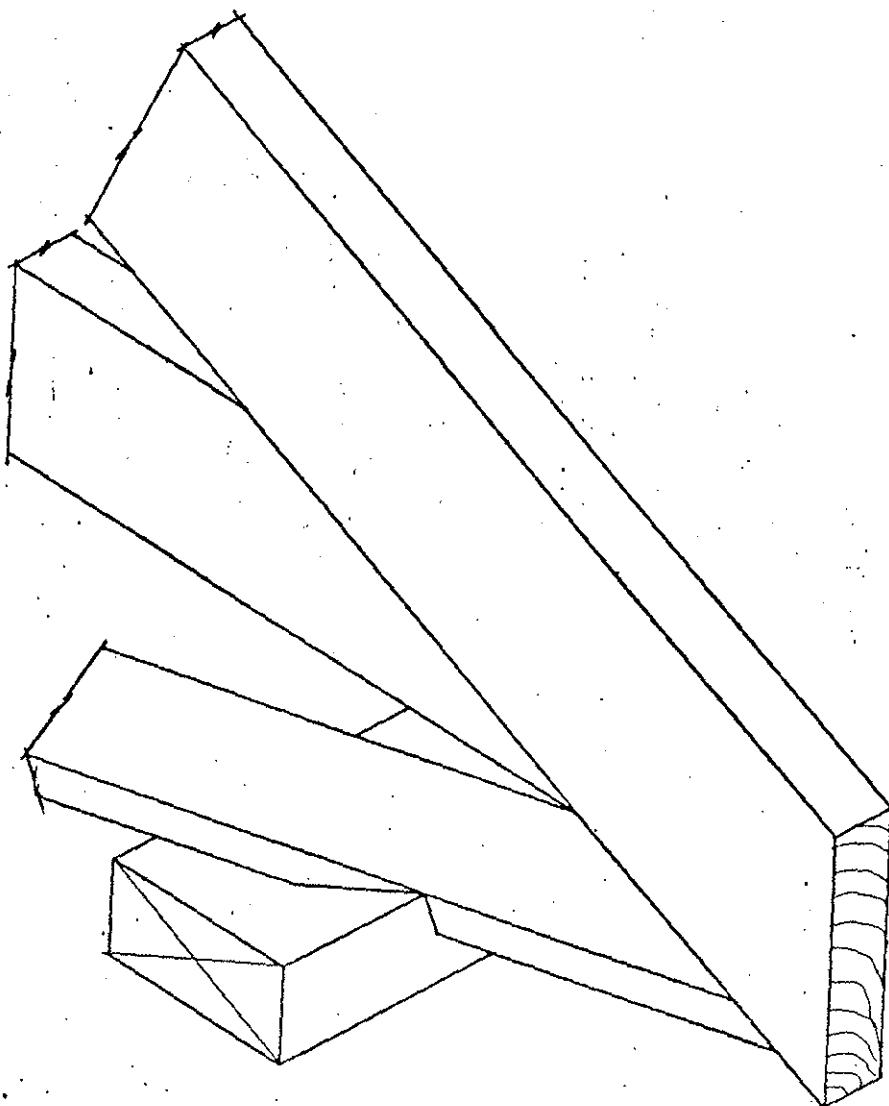
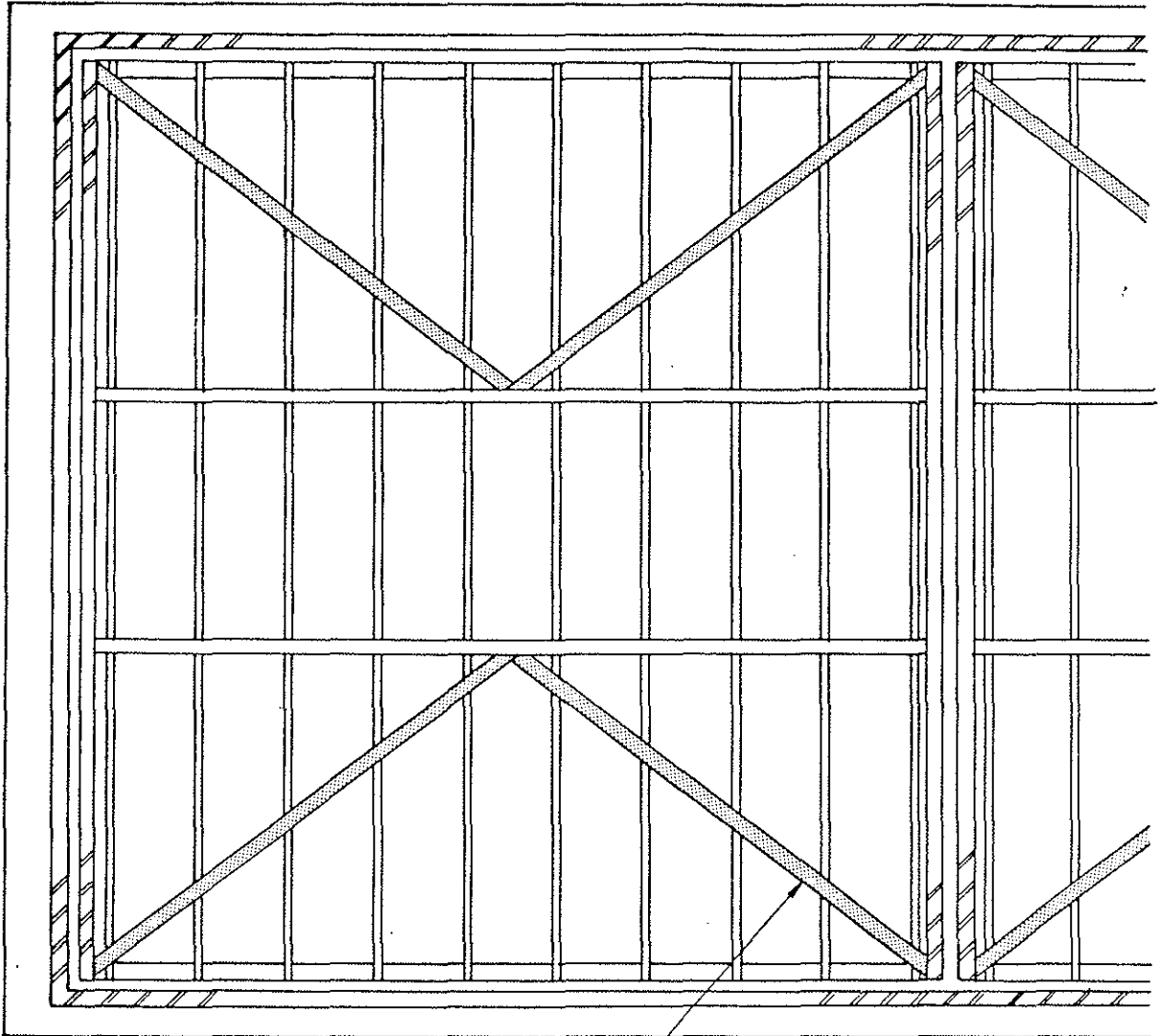

FIG. 2

PLAN ON CEILING TIES



Bracing on top of ceiling ties

FIG. 3

Different types of distortion may occur. One type is shown in an exaggerated way in Fig.4 on the assumption that the node points are firmly held; other buckling modes are possible as described below.

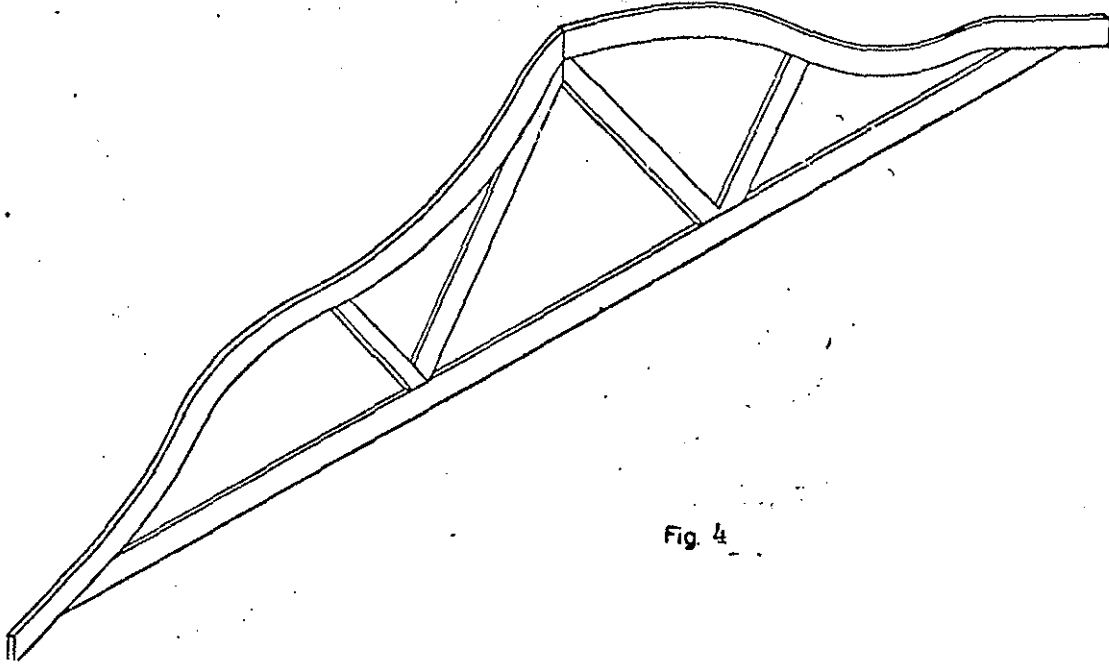

Fig. 4

In some cases, lateral deflection under the normal design loading may be so small that no restraint is necessary. In others, restraint is provided by the tiling battens, but there must be some means of preventing these all moving together as shown in Fig.5. Here it is assumed that the

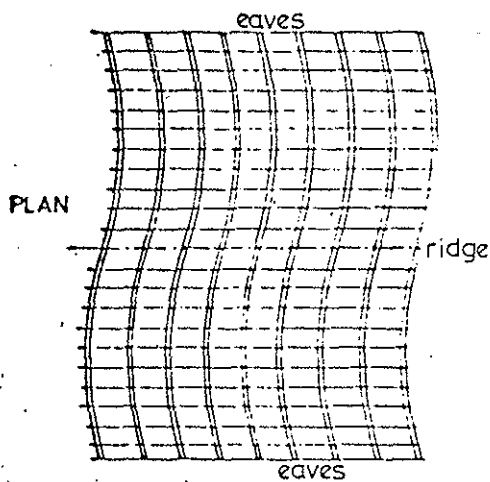

Fig. 5

ridge point is firmly secured but that each rafter is free to move sideways throughout its length. At one time it was thought by some that brick walls at the gable ends could prevent this sort of deformation but it is now generally recognised that this cannot be expected. In Britain a revised Schedule 7 was introduced by the Building Regulations (Third Amendment) 1975 to make it clear that the roof must be designed to provide support for the walls, not the other way round.

Rafter buckling modes

Before going into the types of bracing that have been introduced to prevent sideways buckling, the different ways in which buckling can theoretically take place will be described. In the first one shown in

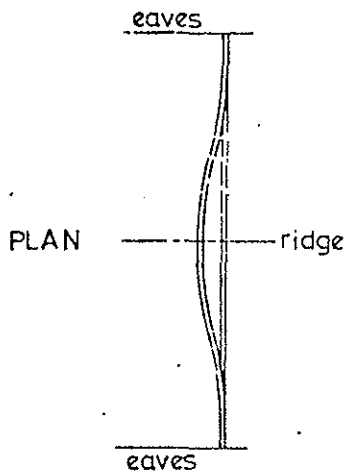

Fig. 6

Fig. 6 the buckling action is rather difficult to visualize. The 'column' is composed of two rafters with a connection at the apex which will generally be less stiff than the solid timber. This whole length carries compressive load and can buckle sideways if the load is great enough. The truss carrying vertical loads on the rafters would be in unstable equilibrium and would topple over if the load was slightly out of balance. To hold it upright while increasing the load to cause lateral buckling, the tie would have to be clamped and the eaves joints would have to have a certain amount of stiffness; with ball-and-socket joints the rafter pair would again simply fall over sideways. Fig. 6 shows the lateral buckling as viewed in plan, with the rafter feet regarded as 'built-in' at the eaves and a ridge joint of a stiffness equal to that of each rafter.

A second buckling mode with the ridge held firmly has been shown in Fig. 5. The rafters below the ridge line in the view are shown buckling to the left and those above it buckling to the right. If all were free to move independently some rafters would tend to buckle in one direction and others in the opposite direction, but since all are connected with tiling battens the overall properties of the whole set will determine how the system buckles.

It would be possible for all the rafters above and below the ridge line in Fig. 5 to buckle in the same direction, i.e. to the left or to the right in the drawing, but this is a much less likely mode than the one shown.

Finally, if all the rafter nodes are prevented from lateral movement then buckling may be as already shown in Fig. 4. This type of buckling is shown in plan for the roof as a whole in Fig. 7.

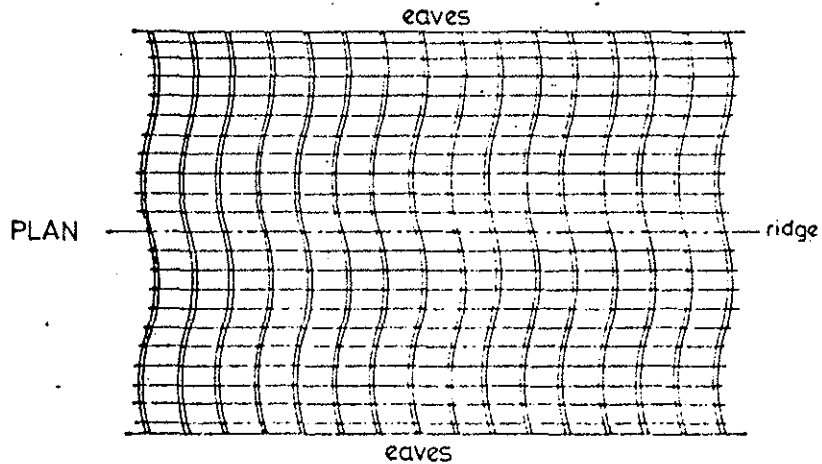

Fig. 7

Most likely buckling mode

The more slender a member is, the more likely it is to buckle sideways in an unbraced roof. In mode 2 buckling, Fig.5, a rafter length of 4 m with a thickness of 35 mm would have a ratio of 114 between length and thickness, and this ratio is used in calculating the lateral buckling propensity of the rafter. With mode 3 buckling, Fig.7, the ratio would be only 57 since only half the rafter length is free to buckle.

The highest value of the ratio and therefore the greatest lateral buckling tendency occurs in the mode 1 buckling shown by Fig.6. No precise theory has been worked out for this case where the 'column' has a bent shape and complex loading, and it was shown above that there is some difficulty in explaining how it occurs in practice. Nevertheless it must occur in preference to the stiffer modes, and in any examination of an unbraced roof where the trussed rafters are said to be 'falling over' or subject to 'domino collapse' it should be suspected that mode 1 lateral buckling is the principal reason for the behaviour.

TYPE OF BRACING

Figs.8 and 9 show the type of rafter bracing recommended by the International Truss Plate Association and in the draft British Code of Practice, BS 5268 Part 3, "Trussed Rafter Roofs". The rafter braces extend from the eaves at the corners of the building upward to a point near the ridge. The two central trusses are thus braced directly against 'mode 1' buckling by the braces attached to them close to the ridge. The trusses remote from these are supported against lateral buckling by the tiling battens which transmit any necessary stabilizing forces towards the centre of the roof and thus into the diagonal braces. Stability against other buckling modes is achieved similarly.

The system shown is used at each gable end and repeated at intervals in longer buildings. In addition longitudinal horizontal members are applied as shown, two at the ceiling nodes, one at each rafter node except for spans below 8 m and one at the ridge. Near the ridge these can be regarded as assisting the tiling battens in transferring truss stabilizing loads to the diagonal bracing. At the intermediate nodes they have a more direct effect for spans over 8 m (Fig.9) because the runner at the rafter node is cross-braced to the one at the ceiling node to produce a form of longitudinal girder transmitting the rafter bracing forces into the ceiling plane.

25 x 100 mm boards are used for the diagonal bracing members, which are fastened where they cross each rafter with two 3.25 mm dia. x 63 mm nails. The Code specifies the minimum size and fixing of the tiling battens to ensure that they will be adequate for the structural duty of helping to prevent lateral buckling of the rafters.

In a well constructed roof the required stabilizing forces will be quite small. With perfectly flat and perpendicular trusses the forces would be theoretically zero, and the Code emphasises that all trussed rafters should be erected truly vertical and parallel at the specified centres, with no bow evident in the length of the truss. In practice there are slight curvatures and member defects having a similar effect. These balance one another to some extent because the whole set of rafters

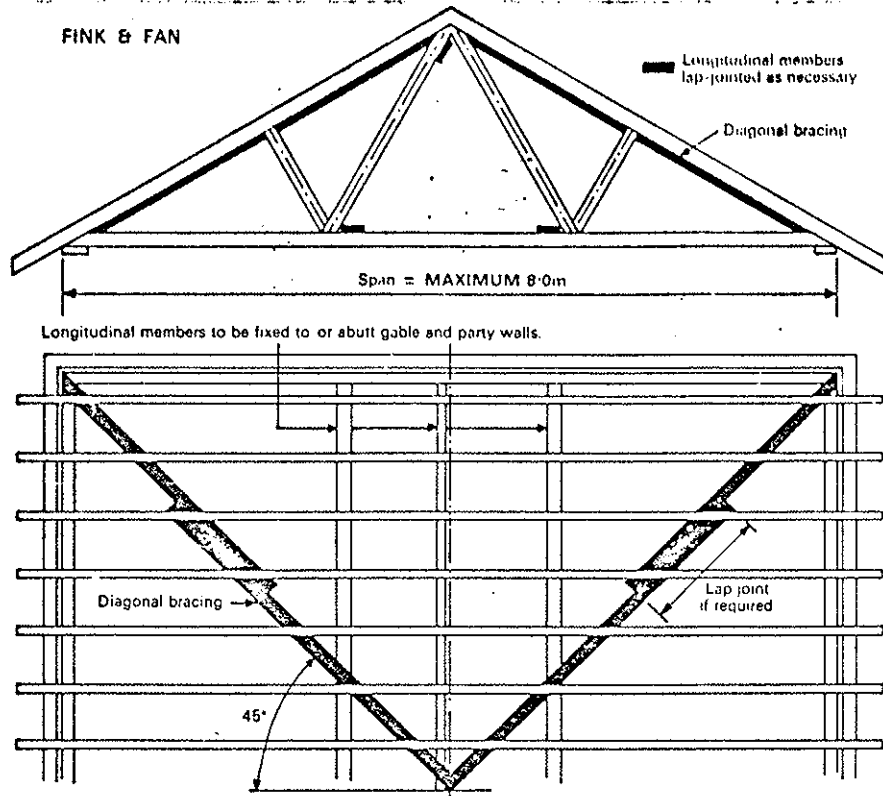

FIG. 8

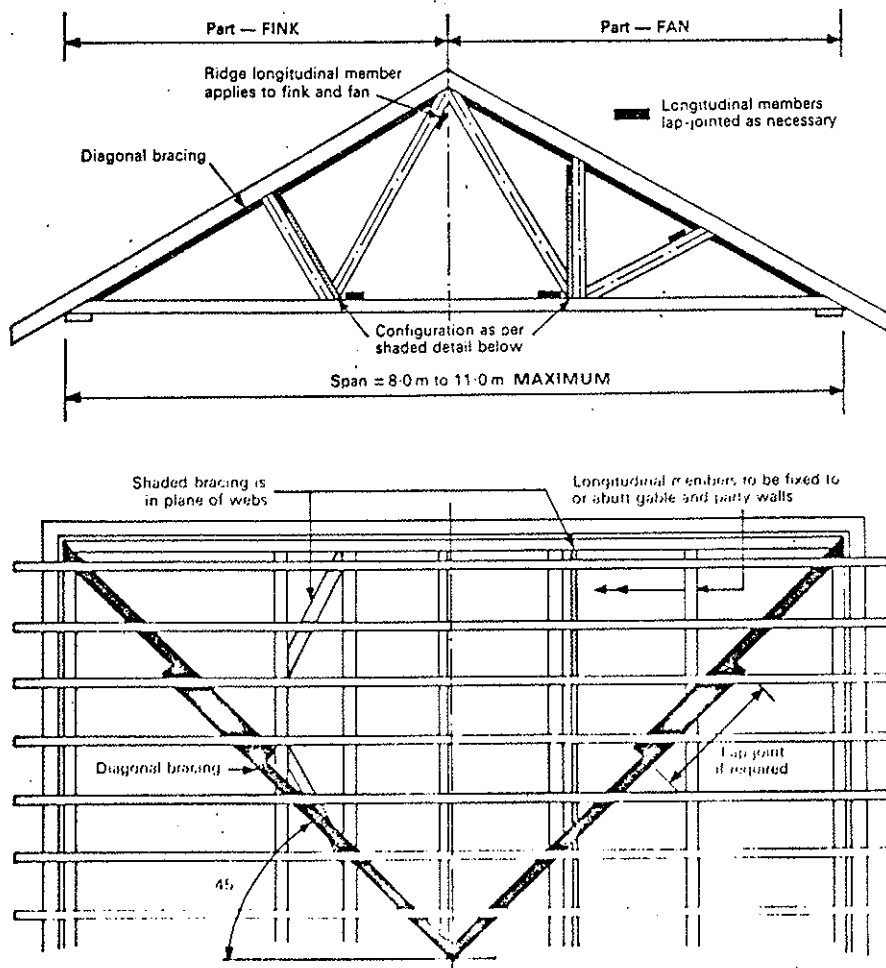

FIG. 9

will not be curved in the same direction, but there will be a residual out-of-balance resulting in a tendency to lateral buckling which is minimised by good construction, and of course the buckling is prevented by an adequate bracing system.

BRACING CALCULATIONS

The following notes deal first with calculations for the remedial bracing of initially unbraced roofs in which lateral buckling has been detected. The calculation of bracing requirements for new roofs is dealt with in a later section; it will be seen that this order is convenient because the calculations for remedial bracing lead to results which are needed in those for the bracing of new roofs.

Remedial bracing of first mode buckling

Buckling in the lowest mode, shown in Fig.6, has been suggested as a type likely to occur and this type has in fact been observed in many unbraced roofs after a number of years in service. First mode buckling is to be expected from the classical theory of buckling¹ applied to columns which are braced only weakly at many points. If full restraint were provided at the tiling batten positions, buckling would occur only between battens. With increasingly weaker restraint, lower modes of buckling would be expected down through those of Figs.7 and 5 until finally with very weak restraint the buckling would be as shown in Fig.6.

A rough indication of the restraint existing in an unbraced roof may be gained from a report of the Princes Risborough Laboratory² giving the results of tests on an unbraced roof with and without tiles as well as on the same roof with different types of bracing added. Without tiles or bracing the restraint was of course extremely low; in engineering calculations it would be taken as zero since a system of trussed rafters with battens pivoted on them would act as a mechanism with no resistance to displacements parallel to the ridge. In the practical construction the joints between battens and rafters do provide a small resistance because of the effect of friction but this would not be taken into account in normal engineering calculations.

With tiles added, the resistance to horizontal displacement was more than six times as great but the added resistance would be frictional. Over a long period in service this type of restraint would tend to be lost due to fluctuation of the wind load and to effects arising from changes in humidity and temperature. The conclusion would still be that even with tiles added the eventual restraint to lateral buckling after long service would be extremely low.

The theory needed to estimate the forces acting in a first-mode buckled roof has been given in a relatively simple form in a previous paper³. At first it deals with the behaviour of a column carrying a lateral distributed load in addition to the end load P , as shown in Fig.10. Later, the restraining forces applied to a laterally buckling trussed rafter will be interpreted as a distributed load on the opposite face of the column.

An initial curvature is assumed, making allowance for defects and other inhomogeneities in addition to actual curvature, and the deflection at any point corresponding to this initial curvature is expressed as

$$y_0 = a \sin \frac{\pi x}{l}$$

where a is the initial deviation from straightness at the centre of the column.

To simplify the calculations, the lateral load is taken as sinusoidal but it may be shown that this leads to a good approximation for uniform loading; in the case of laterally buckled trussed rafters the distribution of the load preventing further buckling is not known with any accuracy but the assumed variation will give the required rough estimate of the bracing forces needed to stabilise a roof.

In Fig.10 the additional deflection due to the lateral load is

$$y_1 = \frac{M}{P_2} \sin \frac{\pi x}{l}$$

and the further deflection y_2 resulting from the longitudinal load may be found from

$$EI \frac{d^2 y_2}{dx^2} = -P(y_0 + y_1 + y_2)$$

$$\text{or } \frac{d^2 y_2}{dx^2} + \frac{P}{EI} y_2 = -\frac{P}{EI} \left(a \sin \frac{\pi x}{l} + \frac{M}{P_2} \sin \frac{\pi x}{l} \right)$$

This equation may be put in the same form as the one for a column without lateral load by taking an enhanced initial deflection

$$a' = a + \frac{M}{P_2}$$

to account for the combined effects of curvature (including defects etc.) and sinusoidal lateral load, giving

$$\frac{d^2 y_2}{dx^2} + \frac{P}{EI} y_2 = -\frac{P}{EI} a' \sin \frac{\pi x}{l}$$

with the complete solution

$$y_2 = A \sin \sqrt{\frac{P}{EI}} x + B \cos \sqrt{\frac{P}{EI}} x + \frac{P}{P_2 - P} a' \sin \frac{\pi x}{l}$$

Since $y_2 = 0$ at $x = 0$ and $x = l$, both A and B are zero so

$$y_2 = \frac{P}{P_2 - P} a' \sin \frac{\pi x}{l}$$

$$\text{or } y_2 = \frac{\alpha}{1 - \alpha} a' \sin \frac{\pi x}{l} \quad \text{where } \alpha = \frac{P}{P_2}$$

The total deflection is found by adding $y_0 + y_1 = a' \sin \frac{\pi x}{l}$
to give

$$y = \frac{a'}{1 - \alpha} \sin \frac{\pi x}{l}$$

and at the centre

$$y_{\max} = \frac{a'}{1 - \alpha} = \frac{a}{1 - \alpha} + \frac{M}{P_2(1 - \alpha)} \quad \text{--- (1)}$$

This expression is the one needed for estimating bracing requirements but the work leads also to the Perry formula which is the basis for column design in BS 5268. The calculations will be taken further to show that the mathematics of column design may be applied also to rafter bracing if extended into a region which would be impractical for column design.

The central bending moment is

$$\begin{aligned} P_y + M &= \frac{Pa}{1 - \alpha} + \frac{PM}{P_2(1 - \alpha)} + M \\ &= \frac{Pa + M}{1 - \alpha} \quad \text{since } \frac{P}{P_2} = \alpha \end{aligned}$$

and the maximum compressive stress is

$$\begin{aligned} \frac{P}{A} + \frac{Pa}{(1 - \alpha)} \frac{h}{A r^2} + \frac{M}{(1 - \alpha)} \frac{h}{A r^2} \\ = C_a + \frac{C_a \eta}{1 - \alpha} + \frac{f_a}{1 - \alpha} \end{aligned}$$

For column design, the need to limit this sum to the permissible compressive value C_g when f_a is zero and to the bending value f_p when C_a is zero led to adopting the revised expression

$$1 = \frac{C_a}{C_g} + \frac{C_a \eta + f_a}{f_p \left(1 - \frac{C_a}{C_g}\right)} \quad \text{--- (2)}$$

which can be solved for c_a to find the maximum longitudinal stress allowed when there is a lateral load giving a maximum bending stress f_a .

Without lateral load

If f_a is zero the expression for a column without lateral load is

$$1 = \frac{c_p}{c_g} + \frac{c_p \eta}{f_p (1 - \frac{c_p}{c_e})} \quad \text{--- (3)}$$

where c_a is replaced by c_p which is the maximum longitudinal stress ($\frac{P}{A}$) sustainable by the same column without lateral load. This quadratic equation when solved for c_p gives the 'modified Perry formula'

$$c_p = \frac{1}{2} c_g + \frac{1}{2} (1 + \frac{c_g}{f_p} \eta) c_e - \sqrt{\left\{ \frac{1}{2} c_g + \frac{1}{2} (1 + \frac{c_g}{f_p} \eta) c_e \right\}^2 - c_g c_e} \quad \text{--- (4)}$$

$$\text{or } \frac{c_p}{c_g} = \frac{1}{2} + \frac{1}{2} (1 + \frac{c_g}{f_p} \eta) \frac{c_e}{c_g} - \sqrt{\left\{ \frac{1}{2} + \frac{1}{2} (1 + \frac{c_g}{f_p} \eta) \frac{c_e}{c_g} \right\}^2 - \frac{c_e}{c_g}} \quad \text{--- (5)}$$

Interaction equation

Eliminating η between equations (1) and (2) leads to the interaction formula

$$\frac{f_a}{f_p (1 - \frac{c_p}{c_g} \frac{c_a}{c_e})} + \frac{c_a}{c_p} = 1 \quad \text{--- (6)}$$

in which $\frac{c_p}{c_g}$ has been written as K_{29} in BS 5268, allowing the use of tabulated values of $\frac{c_p}{c_g}$ to find the value of either f_a or c_a when the other is given.

Application of column design formula

The variation of f_a with c_a may be plotted using either equation (2) or equation (6). This is done in the upper part of Fig.11 using the following numerical values for S2-SS timber with medium term load and with load sharing:

$$\begin{aligned} \frac{l}{r} &= 100 \\ c_g &= 7.0 \times 1.25 \times 1.1 = 9.625 \frac{N}{mm^2} \\ f_p &= 6.9 \times 1.25 \times 1.1 = 9.4875 \text{ .} \\ \eta &= 0.005 \frac{l}{r} \\ E_{\text{mean}} &= 8900 \end{aligned}$$

When used in connection with BS 5268, equation (6) incorporates the 'minimum' value of E divided by a load factor of 1.5. Here, however, the 'mean' value is used without a load factor since the eventual aim will be to estimate the average behaviour of a set of trussed rafters deflecting laterally in unison. At the present stage a single member is being considered.

In the design of columns with lateral load, only the upper part of Fig.11 is applicable, down to the horizontal axis where $f_a = 0$ and the permissible compressive stress is c_p , the solution of equation (3) as a quadratic in c_p . However if plotting of equation (2) is continued for values of c_a higher than c_p then negative values are obtained for f_a . In Fig.11 this is done up to the second point at which the curve meets the horizontal axis, $c_a = c'_p$, and this point corresponds to the value obtained from equation (4) by taking a positive sign before the square root instead of a negative.

The curve between c_p and c'_p is obtained in practice by loading the column on the opposite face, that is on the initially convex instead of the initially concave face. Such loading corresponds to the restraint set up in a trussed rafter buckling laterally, so the ordinary theory leading to the Perry formula is all that is needed to cater for the lateral buckling case also.

At first, only the earlier part of the theory up to equation (1) will be needed. The subsequent calculations leading to equation (4) have the object of ensuring that the greatest combined stress at any point in the column does not exceed the permissible value defined by equations (2) and (3). This condition does not arise when limiting the discussion to behaviour in the plane of the rafters, with laterally buckling occurring to only a small degree.

In these circumstances the stress induced is relatively minor and Fig.11 limiting the stress to permissible values may appear not to be relevant to the problem. However some state of combined stress will appear in the buckled member and a diagram similar to Fig.11 would be obtained for the stress concerned. In later work an estimate of this stress will be obtained to examine its contribution to the total including stresses arising

from behaviour in the plane of the truss, but for the present the calculations will be restricted to lateral deflection.

For the purpose of obtaining a rough numerical estimate of the bracing forces needed, the pair of rafters shown in plan in Fig.6 will be taken as a single very slender column with an effective length equal to the entire span from eaves to eaves and carrying an end load equal to the tie force set up by the design load. To produce a diagram of the type of Fig.11, which was drawn for $\frac{l}{r} = 100$, the same material properties will be used, corresponding to S2-SS timber.

Taking a span of 8080 mm, the lateral $\frac{l}{r}$ for 35 x 97 mm rafters will be $\frac{8080}{10.1} = 800$, giving

$$c_e = \frac{\pi^2 \times 8900}{(\frac{l}{r})^2} = 0.1372 \frac{N}{mm^2}$$

and from equation (4)

$$c_p = 0.1296$$

$$c_p' = 10.189$$

With $\eta = 0.005 \frac{l}{r} = 4.0$, equation (2) becomes

$$1 = \frac{c_a}{9.625} + \frac{4.0 c_a + f_a}{9.4875 \left(1 - \frac{c_a}{0.1372}\right)}$$

$$\text{or } f_a = 9.4875 \left(1 - \frac{c_a}{9.625}\right) \left(1 - \frac{c_a}{0.1372}\right) - 4.0 c_a$$

and this is plotted in Fig.12 using a different scale from Fig.11. Comparing the two diagrams, for $\frac{l}{r} = 800$ the region relevant to normal column design has become very small, and such a slender member could not be used as a column in practice since there is an $\frac{l}{r}$ limitation of 180 in BS 5268. The c_e and c_p values are very close together, and very large 'applied bending stresses' f_a are involved over most of the curve - much larger than the permissible value 9.4875. It will be shown that in this form of calculation the bending stress may be many times the permissible and the compressive stress many times the Euler stress because the two counteract each other so that the permissible combined stress is not exceeded.

Limitation of lateral deflection

A requirement in remedial bracing is to decide what degree of lateral deformation calls for bracing to prevent further buckling, any deformation greater than this limit requiring replacement of the roof. Having decided on a limitation, the problem then is to calculate what bracing will be adequate. For the following calculation a limitation of 40 mm will be imposed, this being additional to the initial central displacement corresponding to an assumed 'curvature' of $0.005 \frac{l}{r}$. The central displacement 'a' for the numerical example is found as usual from

$$\begin{aligned} \eta &= 0.005 \frac{l}{r} = a \frac{h}{r^2} \\ \text{i.e.} &= 0.005 \frac{l}{r} = \frac{6a}{d} \text{ for a rectangular member} \\ a &= \frac{0.005 l}{\sqrt{3}} \\ &= 0.00289 l \\ &= 0.00289 \times 8080 \\ &= 23.35 \text{ mm} \end{aligned}$$

From equation (1) the total deflection is ...

$$y = \frac{a}{1-\alpha} + \frac{M}{P_e(1-\alpha)} \quad \text{where } \alpha = \frac{P_a}{P_e}$$

$$\text{giving } M = P_e \left[y \left(1 - \frac{c_a}{c_e} \right) - a \right] \quad \text{--- (7)}$$

In the numerical example

$$P_e = 0.1372 \times 35 \times 97 = 465.8 \text{ N}$$

For a low pitch truss the assumed span of 8080 mm will correspond to a tie force of about 11000 N, so

$$\frac{c_a}{c_e} = \frac{P_a}{P_e} = \frac{11000}{465.8} = 23.62$$

$$1 - \frac{c_a}{c_e} = -22.62$$

With total deflection $y = a + \text{limitation} = 23.35 + 40 = 63.35 \text{ mm}$,

$$\begin{aligned} M &= 465.8 \left[63.35 \times (-22.62) - 23.35 \right] \\ &= -465.8 \times 1456 \\ &= -678,205 \text{ N.mm} \end{aligned}$$

$$\begin{aligned} \text{and } f_a &= \frac{M}{Z_y} = - \frac{678,205}{19,804} \\ &= -34.25 \frac{\text{N}}{\text{mm}^2} \end{aligned}$$

If M is the central value of the sinusoidal moment distribution

$$m = M \sin \frac{\pi x}{l}$$

with x measured from one end, the corresponding load is

$$q = - \frac{d^2 m}{dx^2} = \frac{\pi^2}{l^2} M \sin \frac{\pi x}{l}$$

When $x = \frac{l}{2}$,

$$\begin{aligned} q_{\max} &= \frac{\pi^2}{l^2} M \\ &= \frac{\pi^2 \times 678,205}{(8080)^2} \\ &= 0.1025 \frac{\text{N}}{\text{mm}} \end{aligned}$$

The total restraint load on the whole span from eaves to eaves is

$$\begin{aligned} Q &= \int_0^l q dx = q_{\max} \int_0^l \sin \frac{\pi x}{l} dx \\ &= -q_{\max} \frac{l}{\pi} \left[\cos \frac{\pi x}{l} \right]_0^l \\ &= \frac{2l}{\pi} q_{\max} \\ &= \frac{2 \times 8080}{\pi} \times 0.1025 \\ &= 527 \text{ N} \end{aligned}$$

A formula giving this result directly is obtained from $Q = \frac{2l}{\pi} q_{\max} = \frac{2l}{\pi} \cdot \frac{\pi^2}{l^2} M$ to give instead of (7)

$$Q = \frac{2\pi}{l} P_e \left[y \left(1 - \frac{c_a}{c_e} \right) - a \right]$$

Restraint load for zero initial curvature

The case without initial curvature is considered partly because the effect of initial curvature may be largely eliminated when a number of trussed rafters buckle in unison, and partly because it gives a comparison with the classical theory for initially straight columns, which will be needed in considering higher buckling modes.

The classical theory makes use of the modulus of the elastic foundation providing the lateral restraint. In the above case if $a = 0$,

$$\begin{aligned} M &= P_e y \left(1 - \frac{c_a}{c_e} \right) \\ q_{\max} &= \frac{\pi^2}{l^2} P_e y \left(1 - \frac{c_a}{c_e} \right) \\ \frac{q_{\max}}{y} &= \frac{\pi^2 \times 465.8}{(8080)^2} (1 - 23.62) \\ &= - \frac{\pi^2 \times 465.8 \times 22.62}{(8080)^2} \\ &= -0.001593 \end{aligned}$$

The value $-\frac{q_{\max}}{y}$ is the modulus of the foundation, i.e. the force per unit length when the deflection is unity. For low values of the modulus, the ideal column buckles as a single half sine wave and the load at which buckling occurs is given by

$$P_{cr} = P_e + \frac{\beta l^2}{\pi^2} \quad \text{where } \beta \text{ is the modulus.}$$

With the above numerical values

$$\begin{aligned} P_{cr} &= 465.8 + \frac{0.001593 \times (8080)^2}{\pi^2} \\ &= 11,004 \end{aligned}$$

- in agreement with the applied axial force (11,000 N). Thus when $a = 0$ the theory above does reduce to the classical result. This can be shown more clearly by writing from above

$$\begin{aligned} \frac{v_{max}}{y} &= -\beta = \frac{\pi^2}{l^2} P_2 \left(1 - \frac{C_0}{C_2}\right) \\ &= \frac{\pi^2}{l^2} P_2 \left(1 - \frac{P_{cr}}{P_2}\right) \\ -\frac{l^2}{\pi^2} \beta &= P_2 - P_{cr} \end{aligned}$$

$$P_{cr} = P_2 + \frac{\beta l^2}{\pi^2}$$

as in the classical theory.

The theory shows that the ideal column buckles in the first mode if the foundation modulus is less than the value given by

$$\begin{aligned} \beta &= \frac{4\pi^4 EI}{l^4} \\ &= \frac{4\pi^4 \times 8900 \times 0.3466 \times 10^6}{(8080)^4} \\ &= 0.0002820. \end{aligned}$$

There is an apparent discrepancy between this value and the much higher value 0.001593 found for the initially curved column buckled to a displacement of 40 mm. The theory for an ideal column indicates that with a foundation modulus of 0.001593 the initially straight column would not buckle in first mode but in a higher mode. The corresponding theory has not been worked out for an initially curved column; even if it was developed and gave indications similar to those for the ideal column, it is possible that the nominally zero restraint in an unbraced roof would lead to first mode buckling which remains when a higher restraint builds up owing to the locking together of tiles and batten-to-rafter joints together with any other actions which hold the roof in its first-mode buckled state.

Foundation modulus from tests

With no bracing the test at the Princes Risborough Laboratory found a lateral deflection of about 5 mm at the ridge under a total force of 1 kN. Taking this deflection as the peak value of a sinusoidal variation over the span length of 7750 mm, the results above may be used to estimate the value of the corresponding modulus as follows

$$\text{Total lateral force } Q = \frac{2l}{\pi} q_{\max}$$

$$q_{\max} = \frac{\pi}{2l} Q$$

$$= \frac{\pi \times 1000}{2 \times 7750} = 0.2027 \text{ N/mm}$$

$$\begin{aligned} \text{Modulus} &= \frac{q_{\max}}{y} = \frac{0.2027}{5} \\ &= 0.04054 \frac{\text{N}}{\text{mm}^2} \end{aligned}$$

The force 1000 N was the total for the 9 trusses incorporated in the test. For a single truss the modulus would be

$$\frac{0.04054}{9} = 0.004504 \frac{\text{N}}{\text{mm}^2}$$

This value is derived from a test with tiles in place. It has been suggested above that in the long term the frictional effects contributing to the stiffness measured in tests would be lost. The test on the same roof without tiles gave a ridge-level deflection of 5 mm with a total horizontal load of about $\frac{1}{6}$ kN, corresponding to a modulus for one truss equal to

$$\frac{\pi \times 167}{2 \times 7750 \times 5 \times 9} = 0.0007522 \frac{\text{N}}{\text{mm}^2}$$

- i.e. about a sixth of the value with tiles. The relaxing of batten-to-rafter stiffnesses in the long term might well reduce the restraint to the level indicated by ideal column theory for first-mode buckling, and of course it may be that with initially curved members such a reduction would not be necessary for first-mode buckling to occur.

Bracing for a set of trussed rafters

The total sinusoidally distributed restraint load found above for a single trussed rafter was

$$Q = \frac{2\pi}{l} P_e \left[y \left(1 - \frac{c_a}{c_e} \right) - a \right] = 527 \text{ N}$$

- the numerical result being based on an initial deviation from straightness of 23.35 mm and a total deflection $y = 40 + 23.35 = 63.35$ mm.

In a set of trussed rafters forming a roof the initial deflections would tend to balance out, but working on the conservative side it will be supposed that the 527 N per truss is a realistic figure that could occur in service, especially as the calculations were based on the mean E value.

For nine trussed rafters the total restraint load required would be $527 \times 9 = 4743$ N. In the buckled roof this load is already applied by the different factors that have been discussed, but these adventitious restraints will be regarded as unreliable in the long term so that they should be replaced by bracing giving the same restraint multiplied by a load factor.

Design of bracing

One remedial bracing method that has been applied for low pitch Fink trusses is shown in Figs.13 and 14. Runners are fitted at all internal nodes (if not already in position) and diagonal braces are added to convert the planes containing the internal struts and the diagonal ties into four girders enabling the three rafter nodes to be held stationary by forces applied from the strengthened ceiling plane.

It will be assumed for the present that the forces applied at the batten attachment points can be collected into the rafter nodes, and means of doing this will be examined later. The forces applied at the nodes may then be found as follows:

$$\begin{aligned} \text{Load at } \frac{1}{4} \text{ point} &= \int_{\frac{l}{8}}^{\frac{3l}{8}} q \, dx = q_{\max} \int_{\frac{l}{8}}^{\frac{3l}{8}} \sin \frac{\pi x}{l} \, dx \\ &= -q_{\max} \frac{l}{\pi} \left[\cos \frac{3\pi}{8} - \cos \frac{\pi}{8} \right] \\ &= \frac{0.1025 \times 8080 \times 0.5412}{\pi} \\ &= 142.7 \text{ N} \end{aligned}$$

$$\begin{aligned}
 \text{Load at centre} &= \int_{\frac{3}{8}l}^{\frac{5}{8}l} q dx = -q_{\max} \frac{l}{\pi} \left[\cos \frac{5\pi}{8} - \cos \frac{3\pi}{8} \right] \\
 &= \frac{0.1025 \times 8080 \times 0.7654}{\pi} = 201.8 \text{ N} \\
 \text{Load at end} &= \int_0^{\frac{l}{8}} q dx = -q_{\max} \frac{l}{\pi} \left[\cos \frac{\pi}{8} - \cos(0) \right] \\
 &= \frac{0.1025 \times 8080 \times 0.0761}{\pi} = 20.06 \text{ N}
 \end{aligned}$$

For a check $(142.7 \times 2 + 201.8 + 20.06 \times 2) = 527.3$ agreeing with the total restraint force 527 N.

The values are marked on Fig.15(a) and for general application they are given under the diagram as fractions of the total.

Internal strut

In Fig.15(b) the force transmitted by a 45° brace is $143\sqrt{2} = 202 \text{ N}$.

With two 3.25 x 75 mm nails,

$$\text{load per nail} = 101 \text{ N}$$

$$\text{J3 permissible load per nail} = 300 \text{ N medium term}$$

$$\text{load factor} = 3$$

Load transferred into ceiling plane = 143 N per truss, without load factor.

Diagonal tie

At the ridge the force 202 N per truss divides into two diagonal tie planes, but each brace caters for two trusses so the horizontal load applied to each brace is still 202 N as marked in Fig.15(c). The force transmitted by a brace at 45° is $202\sqrt{2} = 286 \text{ N}$.

With two 3.25 x 75 mm nails,

$$\text{load per nail} = 143 \text{ N}$$

$$\text{load factor} = \frac{300}{143} = 2.1$$

Load transferred into ceiling plane = 202 N per brace
= 101 N per truss .

Load on ceiling plane

Total load at each $\frac{1}{3}$ point

$$\text{on the ceiling} \quad = 101 + 143 = 244 \text{ N}$$

Taking a roof with 9 trussed rafters, the loading on the ceiling plane will be as shown in Fig.16, with no allowance made for a load factor.

In the roof tested at the Princes Risborough Laboratory the ceiling diaphragm could carry the total load 4.4 kN of Fig.16 with a deflection of about 3 mm. The test was only taken up to about 5.5 kN and it seems possible from the appearance of the load-deflection curve that higher values could have been achieved. To ensure a satisfactory load factor when resisting the load in Fig.16, the bracing system shown in Fig.16 could be applied over the ceiling joists. The ceiling plane also has to cater for wind load on the gable walls, but this will be relatively low with the $17\frac{1}{2}^{\circ}$ pitch being examined.

In Fig.16 the truss stabilising forces are applied along the length of the runner at each $\frac{1}{3}$ point of the ceiling. In the 'structure' shown in the diagram, the junction between a diagonal and a runner would strictly appear at the end of the runner although in practice the second ceiling joist would also be able to transfer force from the runner to the diagonal. For the bare structure shown, the load transferred into the diagonal by two 3.25 mm nails would be only 0.6 kN for medium term load. The load in the diagonal in Fig.16 is $1.1\sqrt{2} = 1.556$ kN, so the bracing with only two nails would leave nearly two-thirds of the 2.2 kN load to be transmitted into the ceiling plane. However taking account of the second ceiling tie it should be possible to justify transfer of half the load to the diagonal, and the remaining half transmitted into the ceiling plane would still leave capacity for resisting wind load on the gable wall.

Collection of rafter stabilising forces to node points

With the rafter nodes braced as shown in Fig.13, it is still possible for buckling between node points to take place giving the fourth mode appearance shown in Fig.4. Here again it is assumed that the adventitious restraint will disappear in the long term and must be replaced by a calculated means of lateral support.

The calculation for first mode buckling used the tie force in conjunction with the distance from eaves to eaves. That for rafter buckling between nodes will be based on the actual distance between nodes together with the rafter thrust calculated as $\frac{11,000}{\cos 17\frac{1}{2}^\circ} = 11,530$ N. The internode distance for the span of 8080 mm used above is 2118 mm.

For the 35 x 97 mm rafter,

$$\begin{aligned}\frac{l}{r_y} &= \frac{2118}{10.1} = 209.7 \\ c_e &= \frac{\pi^2 \times 8900}{(l/r)^2} = 1.998 \frac{\text{N}}{\text{mm}^2} \\ P_e &= 1.998 \times 35 \times 97 = 6783 \text{ N}\end{aligned}$$

$$\begin{aligned}\text{Take again } \gamma &= 0.005 \frac{l}{r} \\ a &= 0.00289 l = 0.00289 \times 2118 \\ &= 6.121 \text{ mm}\end{aligned}$$

$$\frac{c_a}{c_e} = \frac{P_a}{P_e} = \frac{11,530}{6783} = 1.70$$

With first mode sinusoidal curvature over the whole span, the maximum deviation from straightness between the rafter node and the ridge would be about 3 mm for a ridge displacement of 40 mm. Assuming there is local distortion greater than this, a deflection of 6 mm will be taken in addition to 'a', giving

$$\gamma = 6.121 + 6 = 12.121 \text{ mm}$$

$$\begin{aligned}Q &= \frac{2\pi}{l} P_e \left[\gamma \left(1 - \frac{c_a}{c_e} \right) - a \right] \\ &= \frac{2\pi}{2118} \times 6783 \left[12.121 (1 - 1.70) - 6.121 \right] \\ &= - \frac{2\pi \times 6783 \times 14.606}{2118} \\ &= -293.3 \text{ N for one truss} \\ &= 2640 \text{ N for nine trusses}\end{aligned}$$

This degree of restraint may easily be provided by nailing plywood under a pair of adjacent rafters to form a single-skin nailed web beam spanning between node positions as shown in Fig.17. The beam should be formed at about the centre of the roof to minimise the build-up of force in the tiling battens as they gather forces from each trussed rafter in turn

to transmit them to the beam. The force of 293.3 N transferred from each truss to perhaps five battens in each internode space will load each batten nail to only $\frac{293.3}{5} = 58.7$ N compared with the permissible medium-term load of 300 N for a 3.25 mm diameter nail in J3 timber.

The beam also will be lightly loaded with the total restraint force of 2640 N. A single row of 3.25 mm nails at 100 mm spacing will be adequate, using 9 mm plywood of any of the types shown in BS 5268. At the ends of each piece of plywood, filler pieces of 35 x 97 mm timber should be fitted between the rafters to reduce twisting effects caused by applying the batten forces at the top of the rafters while the resisting plywood sheet is on their underside.

SECOND MODE BUCKLING
OF A ROOF WITH INADEQUATELY FASTENED
DIAGONAL BRACES

Second-mode lateral buckling failure has been observed in a number of roofs of one type where sub-standard bracing was fitted and in addition a spine partition below the ridge prevented any tendency to first mode behaviour. The bracing was sub-standard in that only one nail per 'crossing' was applied instead of two. The work above gives a basis for calculations explaining the gross distortions which occurred in this case where some provision was made for lateral restraint.

Fig.18(a) shows the tiling batten displacement in an inadequately braced roof buckling in mode 2. In Fig.18(b) the battens are removed but their positions are marked by arrows representing the forces applied to the diagonal braces by the buckling rafters. This view is taken as a structural model of the rafter planes, the two sides of the roof being folded down to lie in the plane of the paper, and the rafters are shown in plan in the drawing.

The contribution of the rafter stiffnesses to their own lateral restraint is already taken into account in the calculation method, so the rafters will be modelled as having negligible resistance to lateral bending. They do however act as props to the loaded diagonal braces, which will be treated as four-span continuous beams with sinking supports, simply supported at their ends. The axial forces in the rafters are transmitted to them by an inefficient process using a single nail between batten and top of rafter, then a double nail between the bottom of the rafter and the diagonal brace.

In Fig.18(b) the load is antisymmetric so that for every downward load in the left-hand half of the diagram there is an upward load of the same magnitude at the corresponding point of the right-hand half. In the rafter ABCD, if the length AB is shortened by the action of the load then the section CD will be lengthened to the same extent. The part BC and similar parts of other rafters are therefore unaltered in length and may be removed without altering the structural action of the model. To minimise the number of node points in a computer analysis, a quarter of the diagram may then be isolated as shown by Fig.18(c).

To estimate the forces applied to the bracing system and appraise its effectiveness, an initial lateral curvature must be assumed for the rafters, and this will again be taken as $0.005 \frac{l}{r}$. With a pitch of $17\frac{1}{2}^\circ$ and a roof span of 8080 mm as in the previous calculations, the rafter length will be

$$l = \frac{8080}{2 \cos 17\frac{1}{2}^\circ} = 4236 \text{ mm}$$

$$\frac{l}{r} = \frac{4236}{10.1} = 419.4$$

$$C_2 = \frac{\pi^2 \times 8900}{(l/r)^2} = 0.4994 \frac{\text{N}}{\text{mm}^2}$$

$$P_c = 0.4994 \times 35 \times 97 = 1695 \text{ N.}$$

With a rafter axial force of 11,530 N as before,

$$\frac{C_a}{C_2} = \frac{P_a}{P_c} = \frac{11,530}{1695} = 6.802$$

The equivalent initial deviation from straightness for sinusoidal curvature is

$$\begin{aligned} a &= 0.00289 l = 0.00289 \times 4236 \\ &= 12.242 \text{ mm} \end{aligned}$$

In the design of the bracing the additional lateral deflection that may be tolerated must also be specified, and this will be taken as about the same as the initial 'deflection' (a), with the value 12 mm. Then the total deflection is

$$\begin{aligned} y &= a + \text{limitation} = 12.242 + 12 \\ &= 24.242 \text{ mm} \end{aligned}$$

The formula derived above for the total restraint load was

$$\begin{aligned} Q &= \frac{2\pi}{l} P_c \left[y \left(1 - \frac{C_a}{C_2} \right) - a \right] \\ &= \frac{2\pi}{4236} \times 1695 \left[24.242 (1 - 6.802) - 12.242 \right] \\ &= -322.8 \text{ N for one truss} \\ &= 2905 \text{ N for 9 trusses} \end{aligned}$$

As there are two diagonal braces resisting this load, the total to be distributed to each is 1452 N. A sinusoidal distribution will again be taken, giving the values shown for each batten point in Fig.18(c).

Allowance for nail slip

Where the brace crosses each rafter, allowance may be made for nail slip in the computer calculation by altering the cross-sectional area of the rafter. There is also a component of slip perpendicular to the rafter but it may be disregarded because the rafter is taken as having negligible resistance to displacement in this direction.

If x is the component of nail slip parallel to the rafter, the section area A is modified to the value A' giving a change of length equal to the actual change of length plus the nail slip. A' is found from

$$\frac{FL}{A'E} = \frac{FL}{AE} + x$$

$$\text{i.e. } A' = \frac{l}{\frac{l}{A} + \frac{Ex}{FL}}$$

A first run of the computer analysis gave rafter forces starting from the top one as 573, 1028 and 638 N. The corresponding nail slips are worked out using a long-term slip modulus of $600 \frac{\text{N}}{\text{mm}}$, giving for the top member for example

$$\text{long term slip} = \frac{673}{600} = 0.955 \text{ mm}$$

Then the modified area for this member is

$$A' = \frac{l}{\frac{l}{35 \times 97} + \frac{600 \times 0.955}{573 \times 1059}}$$

where 1059 is the member length. With the other two rafter lengths altered similarly, a second computer run gave the new force values 693, 974 and 684 N. Little difference is made to A' if it is altered using the new values because the first term in the denominator is small compared with the second term so that

$$A' = \frac{FL}{Ex} \text{ approximately}$$

and this remains unchanged when a new load is inserted because the slip x is proportional to the load F so that $\frac{F}{x}$ is constant and L and E are also constant. The loads 693, 974 and 684 could therefore be taken as final values if the ends of the diagonal brace were firmly supported and the brace-to-rafter connections could actually transmit these loads.

In fact the connections are overloaded when only one nail per crossing is used as with the sub-standard bracing which was associated with roof failures, and much larger slips would occur corresponding to the overload. The permissible medium term load for a 3.25 mm nail is only 300 N, so in ordinary design three nails per crossing would be called for in the upper and lower connections and four nails in the middle one.

The method of adjusting the area A' using a slip modulus of 600 N/mm is valid for nails which are not overloaded, so the results correspond to adequate nailing at each crossing. With adequate nailing the deflection at the centre of the brace is only about 3 mm. This would be acceptable in ordinary design and would not account for the large deflection observed in the defective roofs even if allowance were made for the severe effect of overload.

When the end fixings of the brace are examined, however, overloading of the single nail at each point is so severe that the supports would be expected to fail completely if the full loading of Fig.18(c) were applied. The resultant nail load is approximately 1380 N, calling for 5 nails at each end.

Fig.19 gives the average load-deflection curve for $2\frac{1}{2}$ in. x 10-gauge nails in standard two-member joints tested at the Princes Risborough Laboratory⁵. An estimate could be made of the deflection at the overloaded rafter nails by using the same factor as at design load for converting from test duration to long term loading, although this might be very inaccurate. In the case of the end nails carrying 1380 N it is evident that they would fail completely even in the short term if full design load were applied.

From what has been written above on first-mode failure, it is clear that for a time the lateral buckling in a newly constructed roof will be resisted by frictional effects. As these are gradually overcome, increasing load will be borne by the bracing system in Fig.18(c) until the end nail fixings become overloaded and give way at an increasing rate until the bracing is completely ineffective and the resistance to lateral buckling falls to a value which for design purposes must be regarded as zero. Lateral buckling of the severity observed in inspections will occur, to a varying extent in different buildings as already discussed.

If adequate nailing can be provided to resist loads of the magnitudes calculated then the opposite is the case and safe behaviour can be expected indefinitely. The rafter bending moments calculated with a nail slip appropriate to the correct nail design load are as shown in Fig.20.

The greatest bending moment is 48,230 N-mm with an accompanying thrust of 158.8 N. There is no greater thrust shown by the computer output, so this combination is the worst. For a 25 x 100 member bending on edge the bending stress is only

$$f_a = \frac{M}{Z} = \frac{48,230}{41,667} = 1.158 \frac{\text{N}}{\text{mm}^2}$$

Evidently a combined stress calculation would show the member to be only lightly stressed and as mentioned already the brace deflection, measured vertically in Fig.18(c), is only about 3 mm.

It should be emphasised at this stage that the discussion so far has been seeking to account for the behaviour of roofs observed to be failing by lateral buckling, and to provide a basis for remedial bracing. The calculation above would not be valid for bracing which is adequately nailed because it assumed a displacement of 12 mm in addition to the initial displacement, whereas the calculation for a well-nailed brace gives only 3 mm. With inadequate nailing leading to greater deflections the state of loading in the calculations would be reached at some time in the life of the roof. With progressively increasing deflection the restraint load required would also increase and the calculation is valid only for a particular stage in the progress of deflection.

Because of the gradually increasing deflection, evaluating its progress and the associated variation of restraint load would be a very complicated matter. Before any deflection takes place, the total sinusoidally distributed restraint load corresponding to the assumed initial curvature (which may not represent the actual lack of straightness very well) may be worked out by putting $y = a$ in the expression for Q to give

$$\begin{aligned} Q &= \frac{2\pi}{l} P_a \left[a \left(1 - \frac{c_a}{c_e} \right) - a \right] \\ &= \frac{2\pi}{l} a P_a \end{aligned}$$

where $P_a = c_a \times A = 11,530$ giving

$$\begin{aligned} Q &= - \frac{2\pi}{4236} \times 12.242 \times 11,530 \\ &= - 209.4 \text{ N for one truss} \end{aligned}$$

compared with 323 N when an additional deflection of 12 mm occurs. The smaller value of Q is still more than adequate to account for runaway deflection of the brace due to overloading of the end nails.

DESIGN FOR ADEQUATE BRACING
OF NEW ROOFS

The above notes have concentrated on the remedial bracing of roofs which are buckling laterally in mode 1 or mode 2.

A calculation method may also be developed for designing the initial bracing to be incorporated in new roofs, but an additional difficulty is introduced because the mode of buckling has to be determined before calculations can be made to ensure the stability of a single half-wave. With remedial work this difficulty does not arise because the mode of buckling is known from inspection of the roof concerned.

In a long column with a number of equally-spaced braces, the mode of buckling is governed by the stiffness of the braces. The usual design objective is to make them stiff enough, and also strong enough, to ensure that buckling under design load multiplied by a suitable load factor would take place between the restraints. The mathematical theory involved leads to complicated results, but simple methods have been presented by Winter⁶ to enable a conservative estimate to be made of the bracing stiffness required and the corresponding brace strength.

Before applying the method, an estimate is required for the brace stiffness in a rafter plane with diagonal bracing of the standard type, fastened in the recommended way with two nails per 'crossing'. Such an estimate can be obtained using the deflections computed for second-mode buckling in relation to Fig. 18(c).

The total force applied to the bracing system was 1452N and the share taken by each of the three braces may be found by multiplying this by the coefficients in Fig.15 as shown in the following table. The vertical force applied to each brace is then divided by the vertical deflection found for each propping point by the computer run, to give the brace stiffness in the table.

	Vertical force at propping point.	Vertical deflection mm	Brace Stiffness N/mm	Stiffness per rafter N/mm
$0.2706 \times 1452 =$	393N	2.23	176	39.1
$0.3827 \times 1452 =$	556N	3.2	174	38.7
$0.2706 \times 1452 =$	393N	2.29	172	38.2

The resulting stiffness values with the average value 174 N/mm give the resistance to displacement perpendicular to the rafters, but the figure 1452N was for $4\frac{1}{2}$ rafters, the two braces in the half roof providing for 9 rafters. The value per rafter is given in the right-hand column of the table.

The brace stiffness required for an ideal column may be worked out from the formula

$$k_{id} = \frac{3.41 P_e}{l}$$

in which the numerical coefficient is applicable to the case with three braces shown in Fig.18(c). As the ridge line may be regarded as held stationary by the bracing system modelled in Fig.18(b), it seems appropriate to consider only the length of one rafter buckling into four half-waves rather than take the whole distance from eaves to eaves in eighth mode buckling. Little difference would be made by taking the latter course, for which a numerical coefficient of 3.85 would be applicable instead of 3.41.

The term P_e in the formula is the Euler load for the interbrace length, incorporating Young's modulus if the l/r value is relatively high or the tangent modulus for smaller values. To avoid the complication involved in the use of the tangent modulus, Winter suggests multiplying the design axial force in the rafter by the same safety factor as used in the U.S.A. for steel column design, and inserting the result as P_e in the formula.

In the case of timber special consideration will be given to the manner of preventing lateral buckling, but for the present the brace stiffness will be found for a P_e value equal to the rafter axial force of 11530N used in connection with second-mode buckling.

$$\begin{aligned}
 k_{id} &= \frac{3.41 P e}{\ell} \\
 &= \frac{3.41 \times 11530}{1059}
 \end{aligned}$$

- where $\ell = 1059$ is a quarter of the rafter length 4236mm used earlier, giving

$$k_{id} = 37.1 \text{ N/mm}$$

- i.e. the required bracing stiffness is very similar to the available stiffness per rafter calculated in the table above. However this is not really an encouraging result. It is the value needed for an ideal column and the figure for an initially curved column which in addition is permitted a certain amount of deflection will be greater. Also, it is calculated for the value 11530N whereas Winter's method requires the design load to be multiplied by a load factor which might have the value 1.5 for a timber column although this question is to be considered later.

To cater for imperfections, the initial curvature will again be taken as

$$0.00289 \ell = 0.00289 \times 1059 = 3.061\text{mm}$$

The symbol d_o instead of a will be used for this value, in agreement with Winter's usage. In considering remedial bracing for first-mode and second-mode buckling, an acceptable further deflection of similar magnitude was adopted. The same will be done here, but it will refer to deflection of the brace and not of the column between braces. Continuing with Winter's symbols, a value $d = 3\text{mm}$ will be allowed. The bracing stiffness required for the column with initial imperfections will then be

$$\begin{aligned}
 k_{req} &= k_{id} \left(\frac{d_o}{d} + 1 \right) \\
 &= 37.1 \left(\frac{3.061}{3} + 1 \right) \\
 &= 75 \text{ N/mm}
 \end{aligned}$$

The required strength of the brace is

$$\begin{aligned}
 \delta_{req} &= k_{req} d = k_{id} (d_o + d) \\
 &= 37.1 (3.061 + 3) \\
 &= 225 \text{ N}
 \end{aligned}$$

With a permissible medium-term load of 300N for a 3.25mm nail, the brace strength available with two nails may be found using the computer output for the structural model in Fig.18(c). The total vertical load gathered into each of the three braces is given in the Table above as 393, 556 and 393N. The forces in the braces found in the computer calculation were 693, 974 and 684N respectively, starting from the top in the diagram. From these figures, the force in a brace may be taken as roughly 1.75 times the vertical load transmitted to it, so a vertical load of 225N will produce a brace force of 394N. With two nails, the actual brace strength is $2 \times 300 = 600\text{N}$, providing a reserve of capacity to resist the 394N brace force.

The calculation of brace strength has been made as though the actual stiffness was equal to the required stiffness $k_{\text{req}} = 75\text{N/mm}$. In fact even without a load factor the stiffness has only about half the value needed. The stiffness required could perhaps be achieved in the short term since much of the calculated deflection comes from using a long term slip modulus of 600N/mm. The slip modulus is used as though the design load were applied in the long term, but only about half of the design load will be of long duration.

Also to be considered are the value 3.061mm given to the initial deflection, and the additional deflection of 3mm. This amounts to an assumption that in a set of connected trussed rafters, where some are initially curved in a way tending to counteract the curvature of others, there will be a residual total initial curvature amounting to an average of 3.061mm per rafter. This does not seem an excessive value to assume in conservative design. The additional deflection of 3mm seems very small as the brace displacement occurring in a rafter over 4m long if overloaded to force it into a laterally buckled shape of four half-waves. Both the values are really part of a design convention on the basis suggested by Winter, with a magnitude for the initial 'curvature' of $d_0 = 0.00289$ times the length compared with his proposal of 0.002 to 0.004 times the length for steel members. The additional

deflection d is taken by Winter as equal to d_0 , and approximately the same course was adopted in the calculation above.

In view of the above arguments, it does seem that a stiffer bracing system is needed for the type of roof discussed, which is typical of many trussed rafter roofs of normal domestic size.

Another important point in connection with eighth-mode buckling as discussed in relation to a particular example is that it leaves a laterally unsupported rafter length equal to three spaces between tiling battens. This can be seen in Fig.21 where lines representing battens have been superimposed on the simplified structural model. The battens shown by solid lines are restrained against movement parallel to the ridge because they pass over points where the diagonal brace crosses rafters. Those shown dotted are not restrained but can move freely parallel to the ridge, so the laterally unrestrained length of each rafter is equal to three batten spaces.

By displacing one of the two braces in the diagram parallel to the ridge through half the distance between trusses, the unrestrained length can be reduced to twice the batten spacing, and with other brace arrangements it is possible to reduce the unrestrained length to a value close to the batten spacing although precise agreement cannot generally be achieved because of interference with internal truss members. This would call for precise specification and close supervision of construction, but perhaps more important is that it would require a severe increase in brace stiffness. The formula above was

$$k_{id} = \frac{3.41Pe}{l}$$

for the case in Fig.18(b) with three braces. Limiting the unrestrained length to the batten spacing in Fig.21 would correspond to buckling in twelve half-waves in the half-roof with a required brace stiffness for the ideal column of approximately

$$\begin{aligned} k_{id} &= \frac{4Pe}{l} \\ &= \frac{4 \times 11530}{353} \\ &= 131 \text{ N/mm} \end{aligned}$$

instead of 37.1 N/mm found for four half-waves in the half-roof.

If the type of bracing in Fig.21 is regarded as a suitable basis for upgrading to provide adequate stiffness for a buckling length of three times the batten spacing, then for a buckling length equal to a single batten spacing three superimposed systems of the type in Fig 21 would have to be upgraded to a still higher level since the new requirement is more than three times the former one.

DESIGN CALCULATIONS FOR RAFTER
BUCKLING IN FOUR HALF-WAVES IN THE HALF ROOF

In the design of trussed rafters it has generally been assumed that adequate lateral restraint for the rafter will be provided at each batten position. The buckling length was then so short that it was felt that the effect of lateral buckling could be ignored although strictly it should be taken into account. The design calculation for a rafter considered only its in-plane behaviour with the objective of limiting the combined stress due to bending moment and thrust to an acceptable level.

With the limitation applied by the standard combined stress formula, the combined stress at the most severely stressed point of the rafter reaches the permissible value under design load, leaving no scope for any addition due to lateral bending. If the design has to cater for a laterally unsupported rafter length equal to three batten spaces in the example considered then provision must be made for a contribution to combined stress caused by lateral buckling.

A calculation making this possible can be based on a theory by Larsen and Theilgaard which provides for initial deviations from straightness in both the elevation of the rafter and its plan. Where displacement in the lateral direction is negligible, the derived equations reduce to those adopted for column design in the CIB code and in BS 5268. In their general form they provide for lateral as well as vertical deflection and for torsional rotation of intermediate cross-sections. The theory leads to a complex expression giving acceptable combinations of bending moment and compressive force, and its authors point out that this would be too complicated for ordinary engineering practice. They give specimen diagrams of a type that would simplify the calculations and go on to present two simple approximate formulae of which the one expressed as follows in CP112 symbols has been selected as the basis of the calculation below:

$$\frac{f_a}{f_r} + \frac{C_a}{C_p} = 1$$

where f_a = applied bending stress
 f_p = permissible bending stress
 c_a = applied compressive stress
 c'_p = permissible compressive stress limited by simultaneous bending in both stiff and weak directions, with the value given by the following expression:

$$c'_p = \left[1 - \left(1 - \frac{c_{py}}{c_s}\right) \left(1 - \frac{c_{py}}{c_{ey}}\right) \frac{c_{ey}}{c_{ex}} \right] c_{py}$$

in which c_{py} = permissible compressive stress for buckling in the weak direction

c_s = permissible compressive stress for a very short column
 c_{ex} = Euler stress for buckling in the strong direction
 c_{ey} = Euler stress for buckling in the weak direction

For a rectangular section with greater dimension d and smaller dimension b ,

$$\frac{c_{ey}}{c_{ex}} = \frac{b^2}{d^2}$$

It is found that for the range of cross-sections used for trussed rafters the expression in square brackets does not differ greatly from unity, so c'_p may be approximated by c_{py} and the design equation limiting the combination of bending and compressive stresses will be based on the modified expression

$$\frac{f_a}{f_p} + \frac{c_a}{c_{py}} = 1$$

The following calculation is made in relation to the diagram in Fig.22 where the battens restraining the rafter against lateral buckling are marked by crosses.

With half fixity, the maximum bay moment is

$$M = \frac{0.8809 \times (2020)^2}{18.5} = 0.1943 \times 10^6 \text{ N-mm}$$

For a 41 x 97 section, $Z = \frac{41 \times (97)^2}{6} = 64,300$

$$f_a = \frac{M}{Z} = \frac{0.1943 \times 10^6}{64,300} = 3.022$$

$$\begin{aligned}
 f_p &= 10.0 \times 1.25 \times 1.1 = 13.75 \\
 C_a &= 11,530 \text{ as used in previous calculations} \\
 c_a &= \frac{11,530}{41 \times 97} = 2.899
 \end{aligned}$$

$$\text{lateral } \frac{l}{r} = \frac{1059 \times 3.464}{41} = 89.47$$

With factor '1.5' dividing E_{\min}

$$\frac{C_e}{C_a} = \frac{\pi^2 \times 6700}{1.5 \times (89.47)^2 \times 11.875} = 0.4638$$

$$\eta = 0.005 \times 89.47 = 0.4474$$

$$\begin{aligned}
 \text{Term for } K_y = A &= \frac{1}{2} + \frac{1}{2} (1 + \eta) \frac{C_e}{C_a} \\
 &= 0.5 + (0.5 \times 1.4474 \times 0.4638) \\
 &= 0.8357
 \end{aligned}$$

$$\begin{aligned}
 \frac{C_{py}}{C_a} = K_y &= A - \sqrt{A^2 - \frac{C_e}{C_a}} \\
 &= 0.8357 - \sqrt{(0.8357)^2 - 0.4638} \\
 &= 0.3513
 \end{aligned}$$

$$\begin{aligned}
 c_{py} &= 0.3513 \times 11.875 \times 1.1 \\
 &= 4.589
 \end{aligned}$$

$$\begin{aligned}
 \frac{f_a}{f_p} + \frac{C_a}{C_{py}} &= \frac{3.022}{13.75} + \frac{2.899}{4.589} \\
 &= 0.2198 + 0.6317 = \underline{0.8515} \text{ compared with 1.0 permissible.}
 \end{aligned}$$

The 41 x 97 section is adequate but a similar calculation shows the 35 x 97 size to be too small.

Calculation with no lateral buckling

The following calculation assuming full lateral restraint is provided for comparison.

$$\begin{aligned} \text{For a } 35 \times 97 \text{ section, } c_a &= \frac{11,530}{35 \times 97} = 3.396 \\ Z &= \frac{35 \times (97)^2}{6} = 54,890 \\ f_a &= \frac{M}{Z} = \frac{0.1943 \times 10^6}{54,890} = 3.540 \\ \text{In plane } \frac{\ell}{r} &= \frac{0.8 \times 2.118 \times 3.464}{97} = 60.51 \end{aligned}$$

Including '1.5' load factor,

$$c_e = \frac{\pi^2 \times 6700}{1.5 \times (60.51)^2} = 12.040$$

$$\frac{c_e}{c_a} = \frac{12.040}{11.875} = 1.0139$$

$$\eta = 0.005 \times 60.51 = 0.3026$$

Term for K_g ,

$$\begin{aligned} A &= 0.5 + (0.5 \times 1.3026 \times 1.0139) \\ &= 1.1604 \end{aligned}$$

$$\begin{aligned} \frac{c_p}{c_a} = K_g &= 1.1604 - \sqrt{(1.1604)^2 - 1.0139} \\ &= 0.5837 \end{aligned}$$

$$\begin{aligned} \text{In plane } c_p &= 0.5837 \times 11.875 \times 1.1 \\ &= 7.625 \end{aligned}$$

$$\begin{aligned} \frac{f_a}{f_p \left(1 - K_g \frac{c_a}{c_e}\right)} + \frac{c_a}{c_p} &= \frac{3.540}{13.75 \left(1 - 0.5837 \times \frac{3.396}{12.040}\right)} + \frac{3.396}{7.625} \\ &= 0.3082 + 0.4454 \\ &= \underline{0.7536} \text{ compared with 1.0 permissible.} \end{aligned}$$

Thus the 35 x 97 section is found adequate when ignoring the lateral buckling effect but has to be raised to 41 x 97 to allow for lateral buckling of an unrestrained length of rafter equal to three times the batten spacing in the example considered.

COMBINATION OF WIND LOAD WITH
BRACING FORCES

All the notes above have been written without reference to wind load on the gable wall, taking account only of the forces applied to the diagonal braces by the tendency to lateral buckling of the rafters. The bracing system shown in Fig.8 above is intended only to prevent lateral buckling and may not be adequate to resist wind loads on walls. The following calculations give a method of estimating the ability of the diagonal braces to cater for wind load on the gable end as well as providing stability for the rafters.

Calculation of wind load

With the ceiling plane attached to the gable wall as required by the revised trussed rafter code prepared as Part 3 of BS 5268, the loaded area supported at rafter level may be taken as that shown shaded in Fig.23. For continuing the numerical example followed throughout this report, the factors in CP3: Chapter V will be taken as $S_1 = 1$, $S_2 = 0.7$ and $S_3 = 1$ giving a design wind speed

$$\begin{aligned} V_s &= V \times S_1 \times S_2 \times S_3 \\ &= V \times 0.7 \text{ m/s} \end{aligned}$$

where V is the basic wind speed.

$$\begin{aligned} \text{Dynamic wind pressure} &= 0.613 V_s^2 \\ &= 0.3V^2 \text{ N/m}^2 \end{aligned}$$

For a semi-detached house of a common shape, 0.7 times this pressure may be taken as acting on the gable wall, i.e.

$$\begin{aligned} \text{wind load per m}^2 \text{ on wall} &= 0.3 \times 0.7V^2 \\ &= 0.21V^2 \text{ N/m}^2 \end{aligned}$$

The shaded area in Fig.23 is $\frac{l^2}{8} \tan \theta$ so the total wind force at rafter level is

$$\begin{aligned} F &= 0.21V^2 \cdot \frac{l^2}{8} \tan \theta \\ &= 0.02625V^2 l^2 \tan \theta \end{aligned}$$

For the example with span 8.08 m and pitch $17\frac{1}{2}^{\circ}$, taking the basic wind speed as 48 m/s,

$$\begin{aligned} F &= 0.02625 \times (48)^2 \times (8.08)^2 \tan 17\frac{1}{2}^{\circ} \\ &= 1245 \text{ N} \end{aligned}$$

With a load per square metre of $0.21V^2 = 483.84 \text{ N/m}^2$ on the shaded area, the force at each of the quarter points in the half roof will be as shown in the diagram. For simplicity these points are taken at the positions where the brace crosses each rafter in Fig.22.

It will be assumed that the load 291.83 at the gable peak is resisted by axial forces in the diagonal members of Fig.18(b), leaving three loads (77.81, 155.63 and 233.44) to be resisted by the brace acting as a beam. For estimating their contribution to the combined action of lateral and axial forces on the brace, it will be a great convenience to take the wind load as sinusoidally distributed. This is not correct but will give a means of estimating roughly the combined effect of wind and bracing loads for design purposes.

The assumption may be supported by the fact that the wind loading is not antisymmetrical and the 233.44 N load has a stiffer mechanism resisting it than the 77.81 N load. In Fig.18(b) rafter lengths such as BC are removed when the load is antisymmetrical to produce the model in Fig.18(c). The same model can be justified approximately for wind load only because the 'shortening' of members such as AB in the model arises mainly from nail slip. When applying the same model for wind load, the section removed near the centre of the diagram (load 233.44 N) is shorter than the one remote from the centre (load 77.81 N); in the actual structure the 233.44 N will have the greater resistance because of the shorter section removed at the point where it acts.

Taking a sinusoidal wind load distribution with a peak value of 155.63, the wind forces acting on the brace will be as shown in Fig.24 after halving their values because there are two braces in the half roof. The effect of wind loading on the brace is two-fold:

- (1) it causes additional deflection of the brace, allowing the axial rafter forces to apply greater bracing loads,

- (2) it applies extra bending moment to the brace acting as a beam.

The wind load will be applied at different times throughout the service life of the structure, but its most severe effect will occur when the greatest degree of lateral deflection has taken place after long service. Two cases will be considered, one where the wind effect is added to the eventual effect of long-term load, and one where the wind effect is added to the eventual effect of medium term load.

Long term load plus wind

Taking the long-term load as half of the full design load, the forces and deflections in the Table on page 33 will be halved, but of course the stiffness at each of the three propping points will remain the same at approximately 38.7 N/mm per rafter.

The long-term force in the rafter is $\frac{11,530}{2} = 5765$ giving the required bracing point stiffness for an ideal column as

$$k_{id} = \frac{3.41 \times 5765}{1059}$$

$$= 18.58$$

- i.e. half the value 37.1 found on page 34.

In the theory for a laterally loaded column given on pages 11 to 13, the effect of a sinusoidally-distributed lateral load was allowed for by taking an increased initial curvature. The same may be done to allow for the wind load, adding the deflection it causes to the assumed initial deviation from straightness, d_0 in the formula at the bottom of page 34.

The wind load deflection for the loading in Fig.24 may be estimated using a short-term slip modulus of 2600 N/mm for the nails, this value actually corresponding to the duration of the tests from which the long-term modulus of 600 N/mm was derived⁴. After modifying member areas in the manner described on page 28 to allow for nail slip, a computer analysis for the loading in Fig.24 gives the wind deflection as 0.1389 mm in a direction perpendicular to the rafters at the centre propping point. Using the symbol d_w for wind deflection in a modified formula, the required brace stiffness is

$$\begin{aligned}
 k_{req} &= k_{id} \left(\frac{d_o + d_w}{d} + 1 \right) \\
 &= 18.58 \left(\frac{3.061 + 0.139}{3} + 1 \right) \\
 &= 38.4 \text{ N/mm}
 \end{aligned}$$

This is very similar to the available stiffness 38.7 N/mm, but again no load factor has been applied to the rafter thrust of 5765 N arising from the long term load.

Medium term load plus wind

The medium-term calculation will consider full design load in conjunction with a medium-term brace stiffness to allow for the expected deflection after long service, and the short-term wind deflection to be added will have the same value as already found, 0.139 mm.

To find the available medium-term brace stiffness, an intermediate slip modulus of 1200 N/mm is applied for the loading in Fig.24, and a computer run gives the deflections in column 2 of the following Table:

Vertical force at propping point N	Vertical deflection mm	Brace stiffness N/mm	Stiffness per rafter N/mm
55	0.1685	326.4	72.5
77.8	0.2450	317.6	70.6
55	0.1780	309.0	68.7

The average propping-point stiffness is 70.6 N/mm.

The value of k_{id} using the full design load rafter force of 11530 for medium-term load is the same as found on page 34, 37.1 N/mm. Then

$$\begin{aligned}
 k_{req} &= k_{id} \left(\frac{d_o + d_w}{d} + 1 \right) \\
 &= 37.1 \left(\frac{3.061 + 0.139}{3} + 1 \right) \\
 &= 76.7 \text{ N/mm}
 \end{aligned}$$

The available medium-term stiffness (70.6) is nearly enough to match the required stiffness, but no load factor has been applied to the rafter thrust of 11530 N due to the combination of dead and snow loading.

Conclusions

The critical case is that for medium-term load, but with a greater proportion of dead to imposed load the long-term loading might be found critical. In this example with 8.08 m span and $17\frac{1}{2}^{\circ}$ pitch, the short-term wind load does not have much effect on the results. However with higher spans and pitches it would have an important effect.

In view of the low span and pitch considered, with a basic wind speed of 48 m/s, the results confirm the importance of supporting the gable wall at ceiling level in all cases to reduce the proportion of the wind load carried at rafter level. Bearing in mind the discussion on page 35 and the fact that no load factor has been applied to the rafter thrust in the calculations, it appears that even with a modest span and pitch where the wind load has only a small effect, it is difficult to justify the adequacy of 25 x 100 mm braces with two nails per crossing even if they are repeated throughout the length of a long roof with no interval between sets of bracing.

FURTHER CONSIDERATION OF WIND LOAD EFFECT

The wind load deflection 0.1389 mm at the foot of page 45 may be regarded as derived from the 'most pessimistic stiffness' of the bracing system under wind loading. It is based on the model in Fig.24 which was chosen as appropriate for the antisymmetric loading of Fig.18(b). When applied for wind loading, the model assumes that turbulence at some time during the erratically-changing wind behaviour will give rise to a loading approximating that in Fig.18(b), implying that pressure is applied to one half of the gable and suction to the other half.

Another possibility giving the 'most optimistic stiffness' is to analyse the structure in Fig.25(a) under wind loading taken here as uniform across the gable. For studying only the bending tendency of the brace, a quarter of the structure may be analysed as shown by Fig.25(b). As before the rafters are given a very low inertia in the computer input and their areas are modified to allow for nail slip which again plays an important part even with the high slip modulus of 2600 N/mm taken for wind loading. The modified area with two parts to the rafter at each propping point is given by

$$A' = \frac{1}{\frac{1}{A} + \frac{E\alpha(L_1+L_2)}{L_1 L_2 F}}$$

in comparison with page 28 for the case with one-part props. The symbols L_1 and L_2 are taken as referring to the left-hand and right-hand parts of each rafter in Fig.25(b).

The loads in Fig.25(b) are the actual values in Fig.23 rather than a sinusoidal replacement distribution, but are halved because there are two braces in the half roof. The load 291.83 N at the ridge is omitted.

The computer output gives the forces and deflections at each propping point, measured at right angles to the rafter, as shown in the following Table.

Point No.	Vertical force at propping point N	Vertical deflection mm	Brace stiffness N/mm	Stiffness per rafter N/mm
2	38.9	0.0715	544	120.9
5	77.8	0.1424	546	121.3
8	116.7	0.1691	690	153.3

The corresponding Table for Fig.24 is as follows:

Point No.	Vertical force at propping point N	Vertical deflection mm	Brace stiffness N/mm	Stiffness per rafter N/mm
2	55	0.0929	592	131.6
4	77.8	0.1389	560	124.4
6	55	0.1035	531	118.0

Comparing the two tables, it can be seen that for the upper two propping points the stiffness referred to as the 'most optimistic' (upper table) is actually lower than for the 'most pessimistic' antisymmetric sinusoidal loading although of similar magnitude. The full nail slip corresponding to the prop load is inserted in either case, and its dominant effect must swamp the effects of the different configurations and loadings.

The central deflection of the brace in the two tables is not too dissimilar, so it seems that the antisymmetric sinusoidal loading is a reasonable replacement for the uniform gable loading. This could be argued not only for its simplicity but also as a realistic estimate of a type of disturbance likely to occur sporadically under wind gust loading, so the conclusions in the previous section of this report will be retained as unaffected by this further discussion.

1. TIMOSHENKO, S.P. AND J.M. GERE - Theory of Elastic Stability, 2nd Edition, 1961.
2. MAYO, A.P. - Trussed rafter roofs - load distribution and lateral stability. BRE Information Sheet IS 24/78, November 1978.
3. BURGESS, H.J. - Ties with lateral load. (Reviews column theory before going on to tension members). Proceedings of the International Union of Forestry Research Organisations, Oxford, April 1980.
4. BURGESS, H.J. - Nail deflection data for design. Paper No.13-7-6, Conseil International du Bâtiment, Working Commission W18 (timber structures), Helsinki, June 1980.
5. BROCK, G.R. - The strength of nailed joints. Forest Products Research Bulletin No.41, 1957.
6. WINTER, G. - Lateral bracing of columns and beams. Jl. Struct. Div., ASCE, Paper 1561, March 1958.
7. LARSEN, H.J. and THEILGAARD, E. - Laterally loaded timber columns. Jl. Struct. Div., ASCE, July 1979.

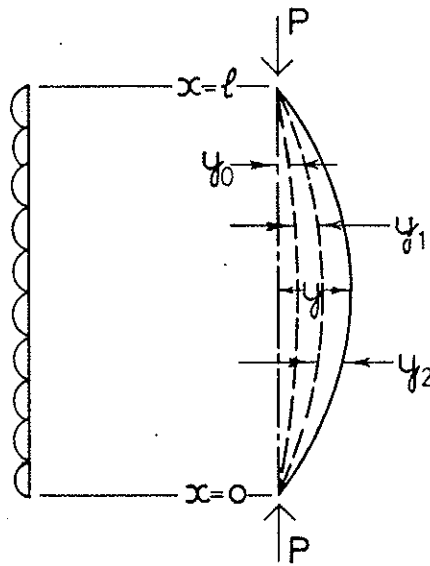

COLUMN WITH LATERAL LOAD

Fig. 11

LIMITATION OF COMPRESSION
ON INITIALLY CONCAVE FACE
 $\frac{L}{r} = 100$

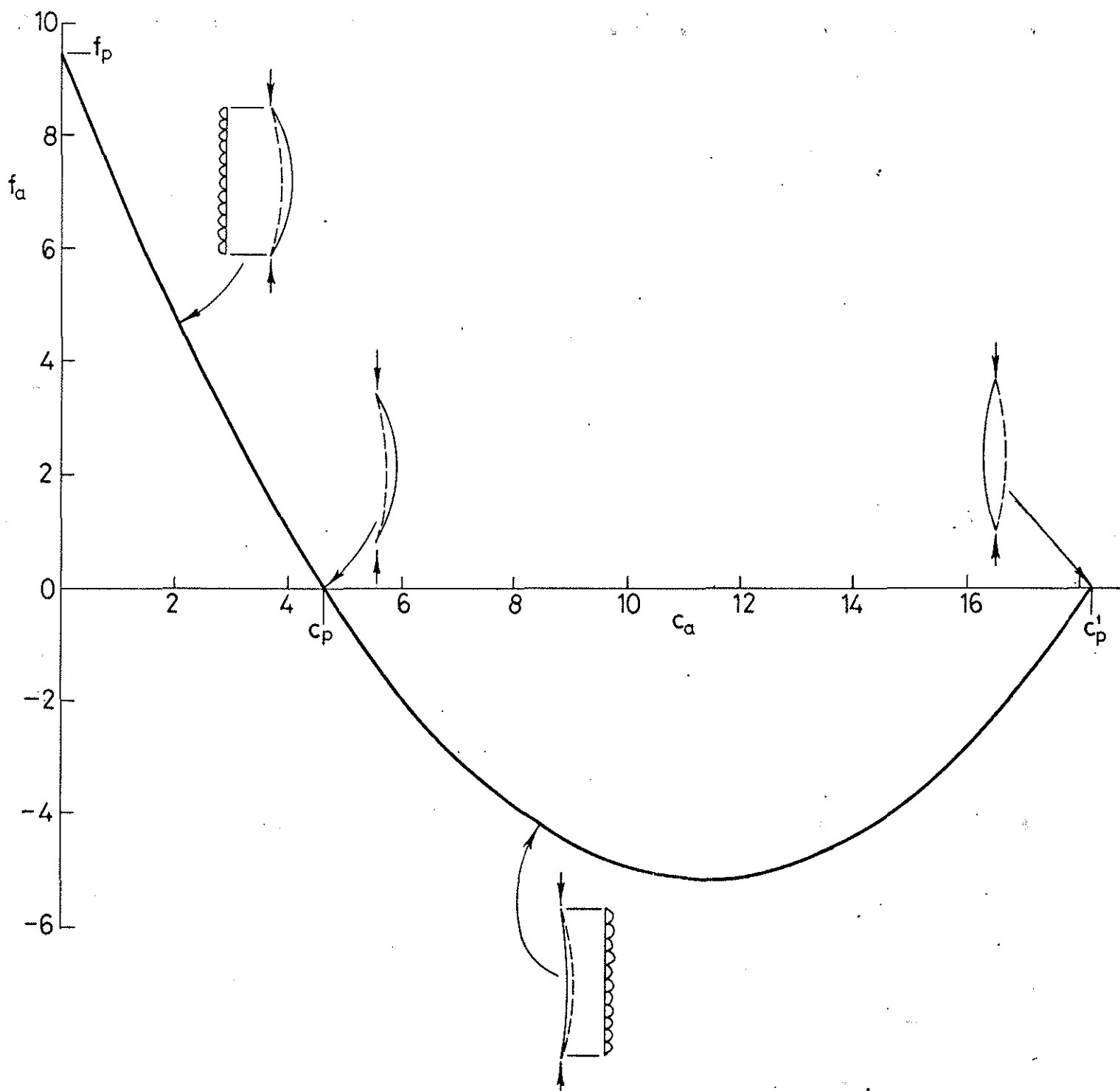
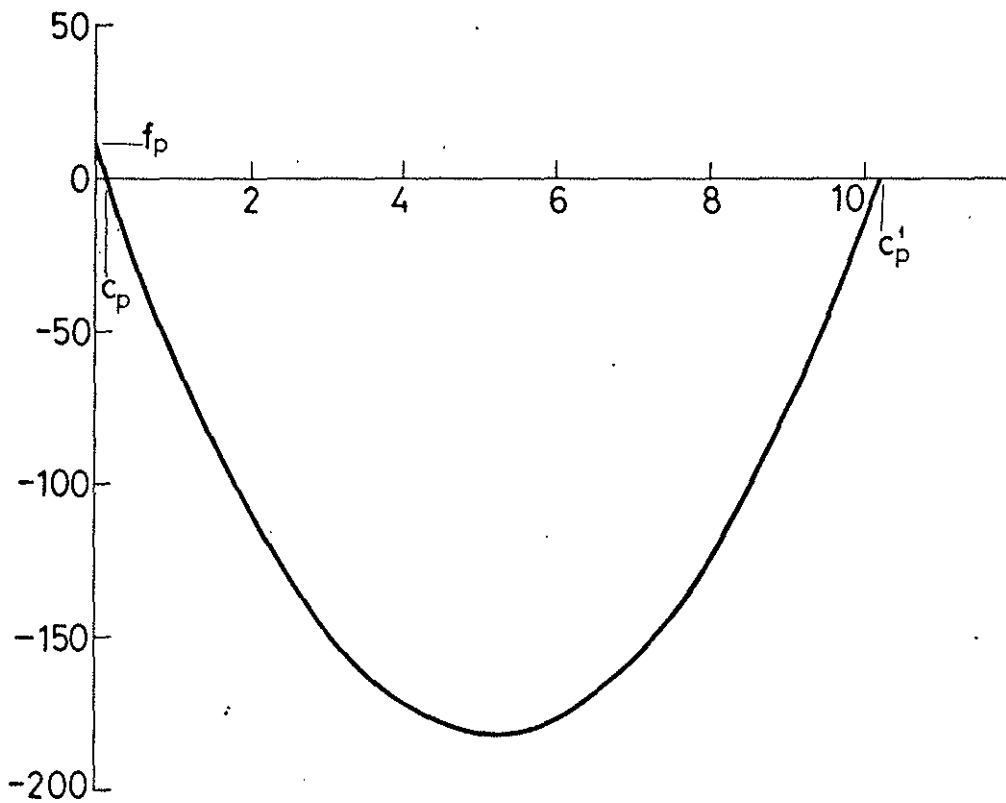
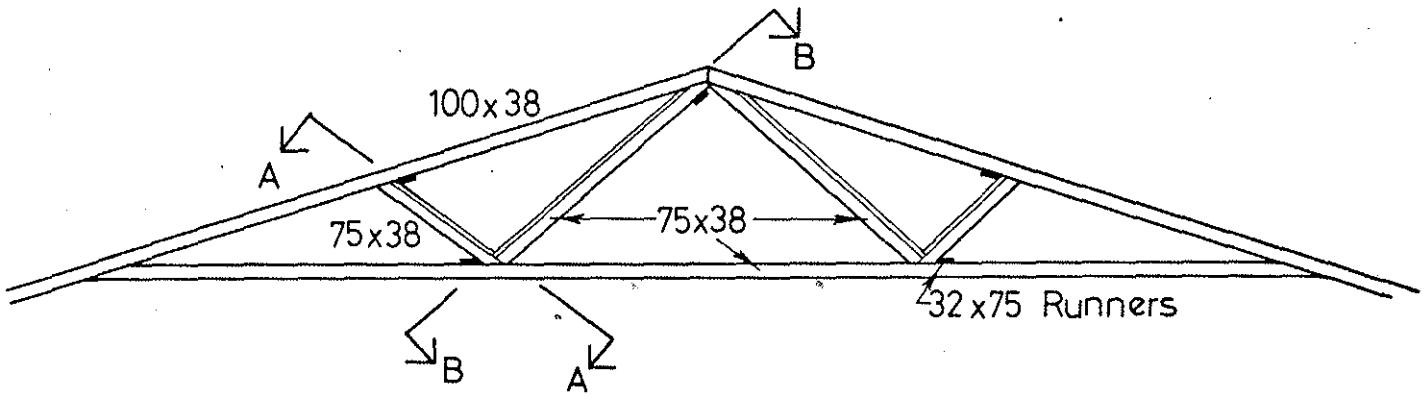

Fig. 12

LIMITATION OF COMPRESSION
ON INITIALLY CONCAVE FACE

$$\frac{e}{r} = 800$$





Fink truss

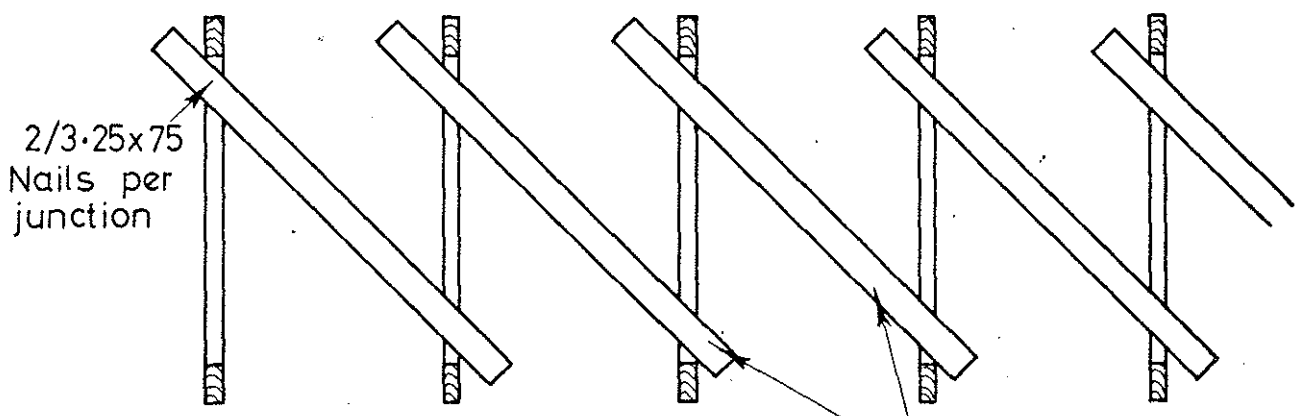

Section AA (Runner omitted)

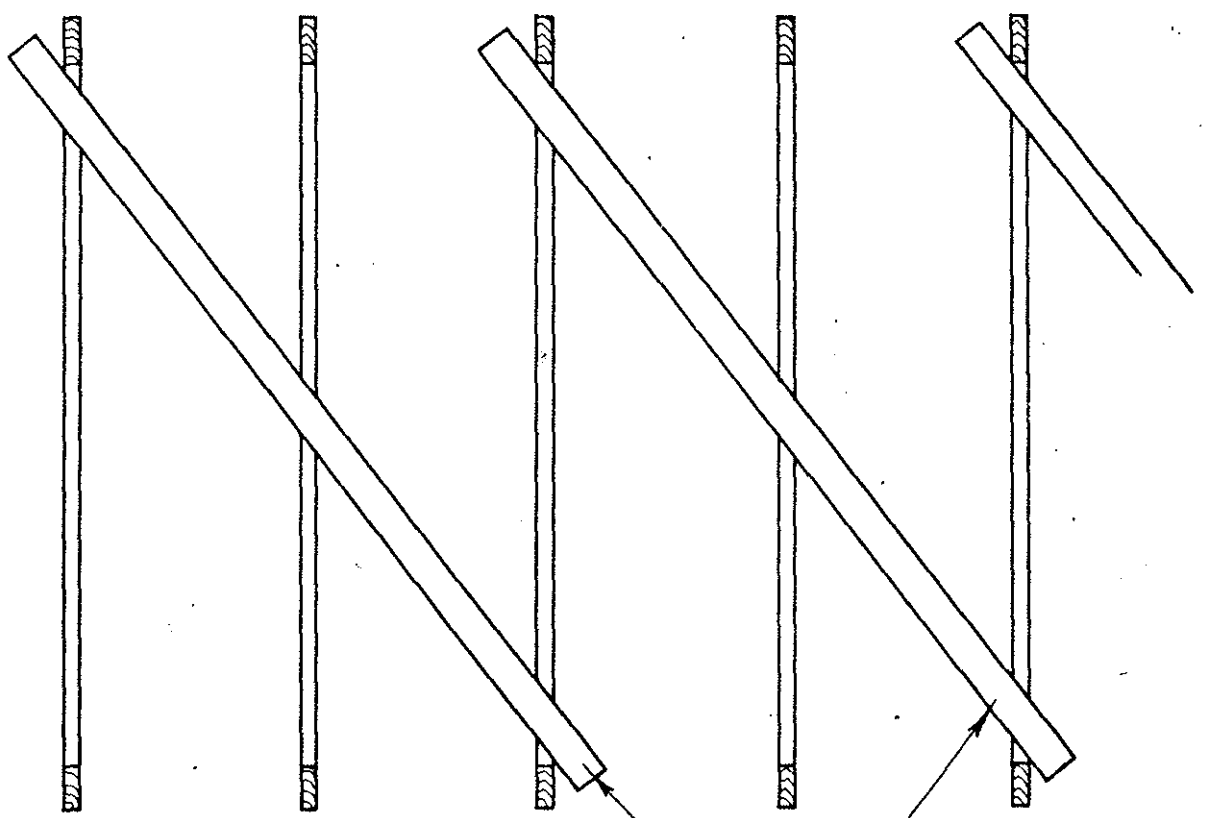

Section BB

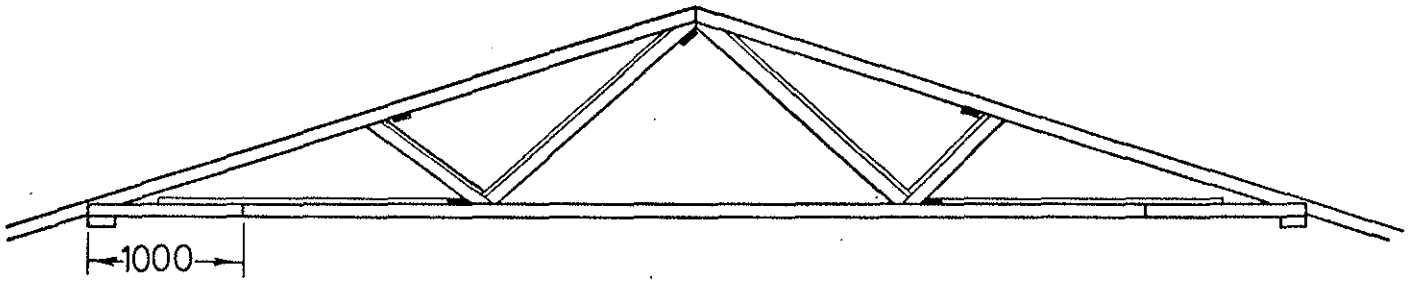

Elevation - Fink truss

All bracing fixed with 2/3-25x75 nails per junction

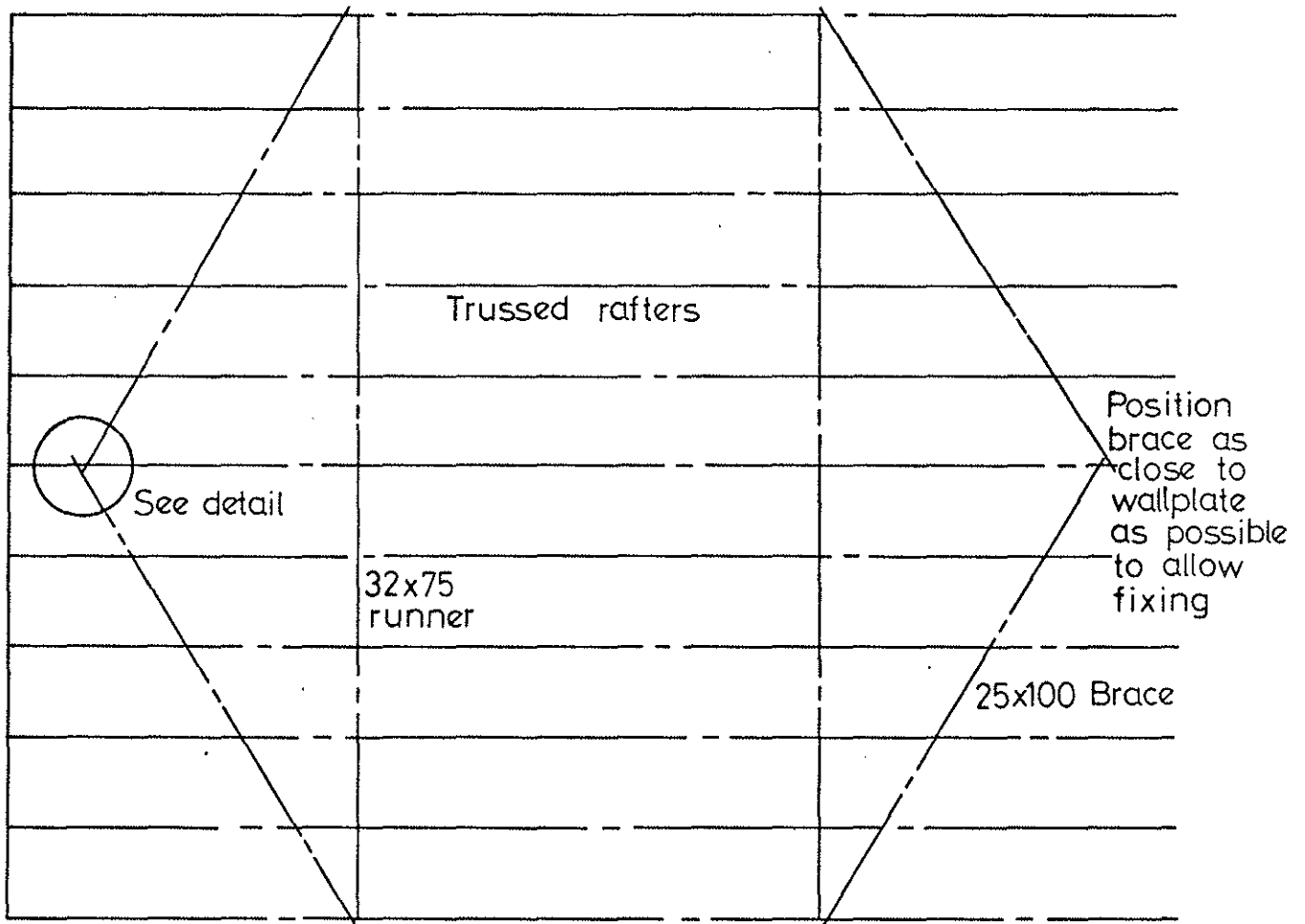

Plan - bracing in ceiling plane

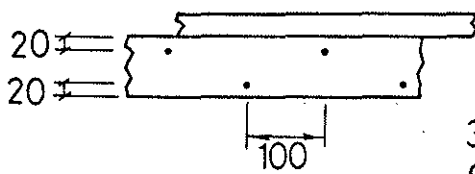

Nailing pattern to continue as close as practical to eaves, use 3-25x75 nails.

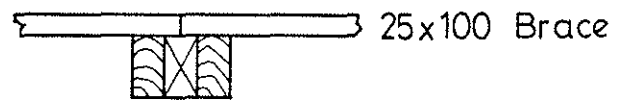

38x75 members nailed to ceiling tie, placed as close as possible to wallplate.

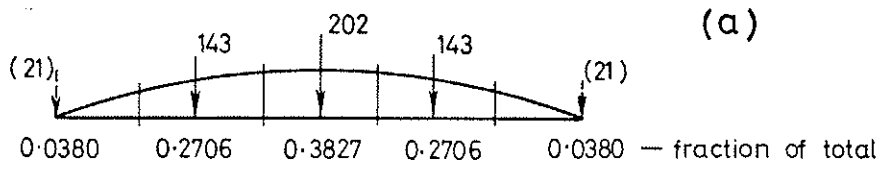

Section A-A of Fig. 13

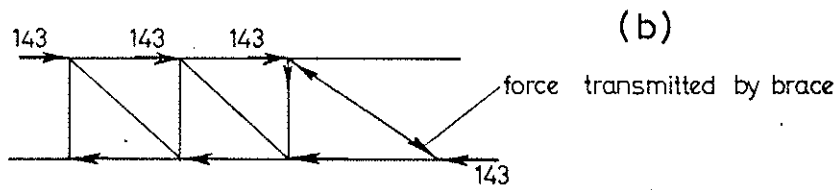

Section B-B of Fig. 13

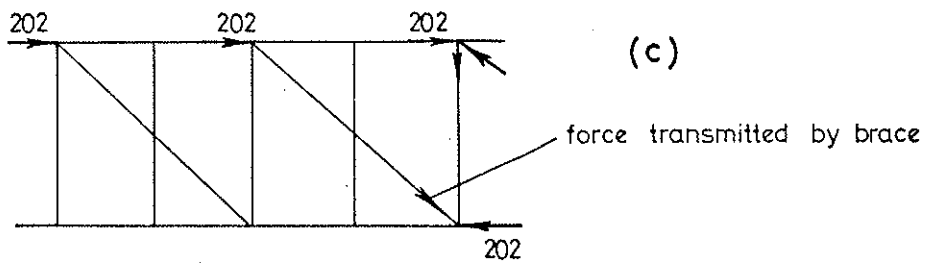
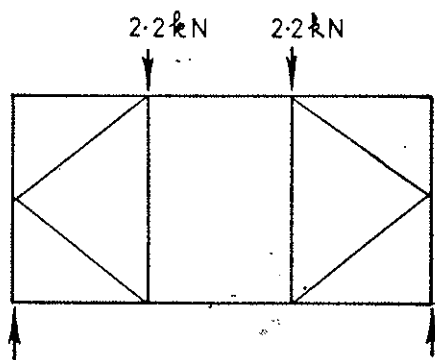
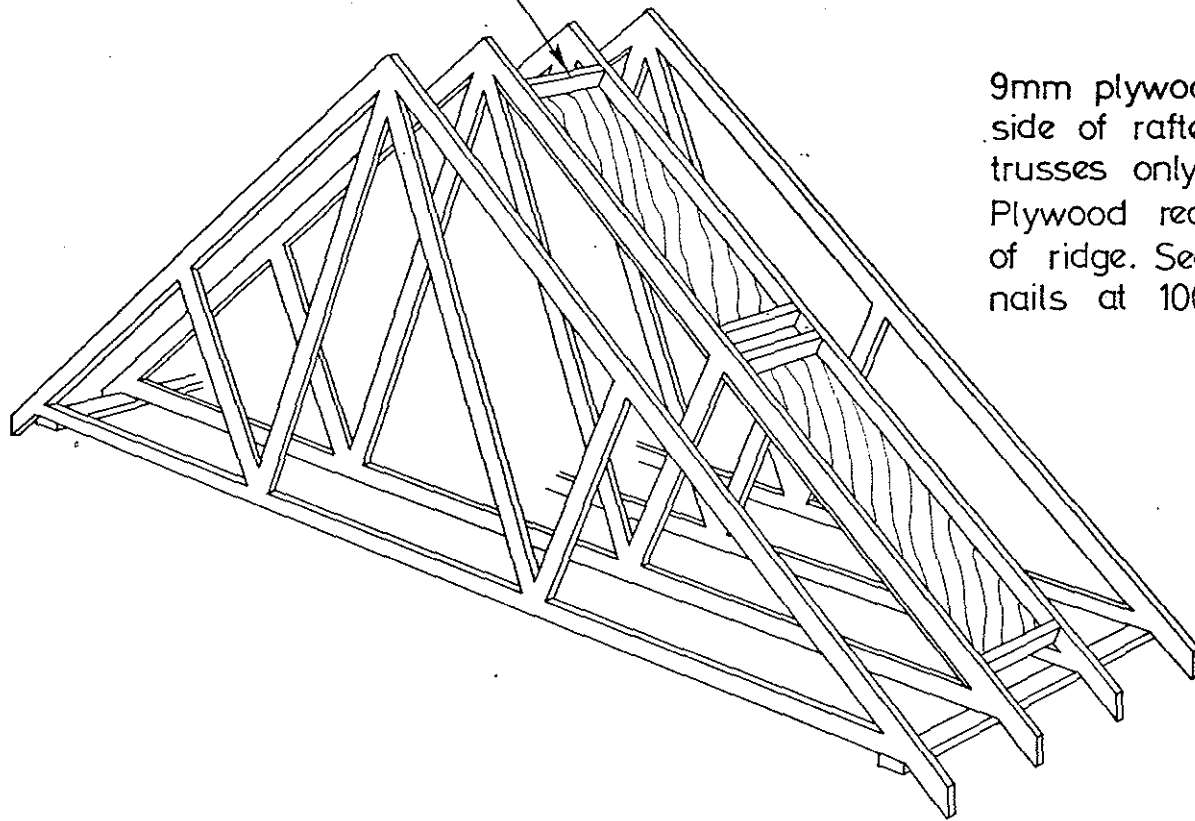

Fig. 16



Filler pieces same
section as rafters



9mm plywood sheets on under
side of rafters for one pair of
trusses only, near centre of roof.
Plywood required on both sides
of ridge. Secure with 3.25mm
nails at 100mm centres.

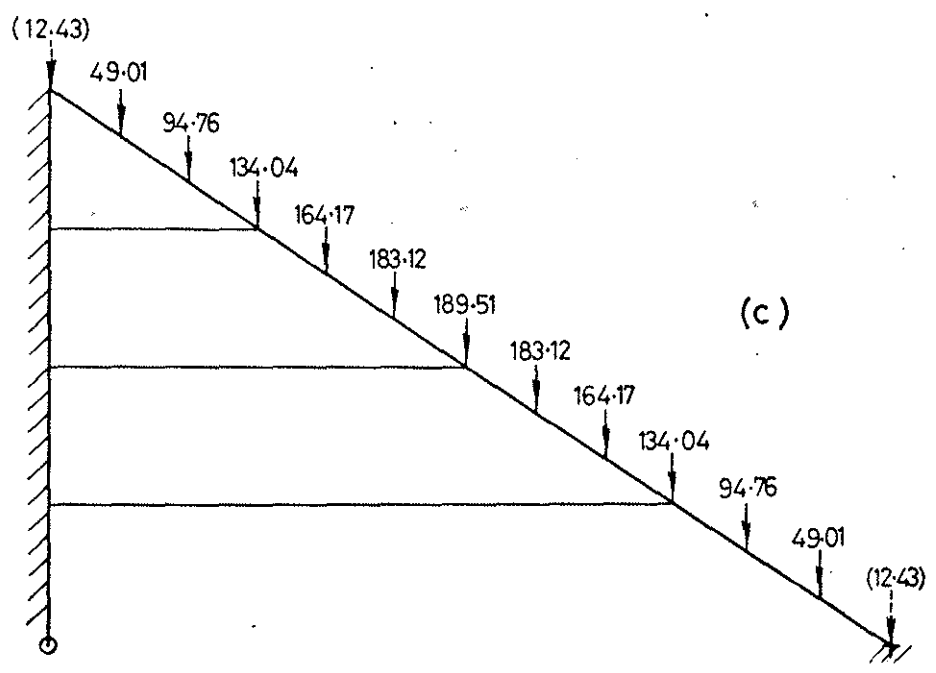
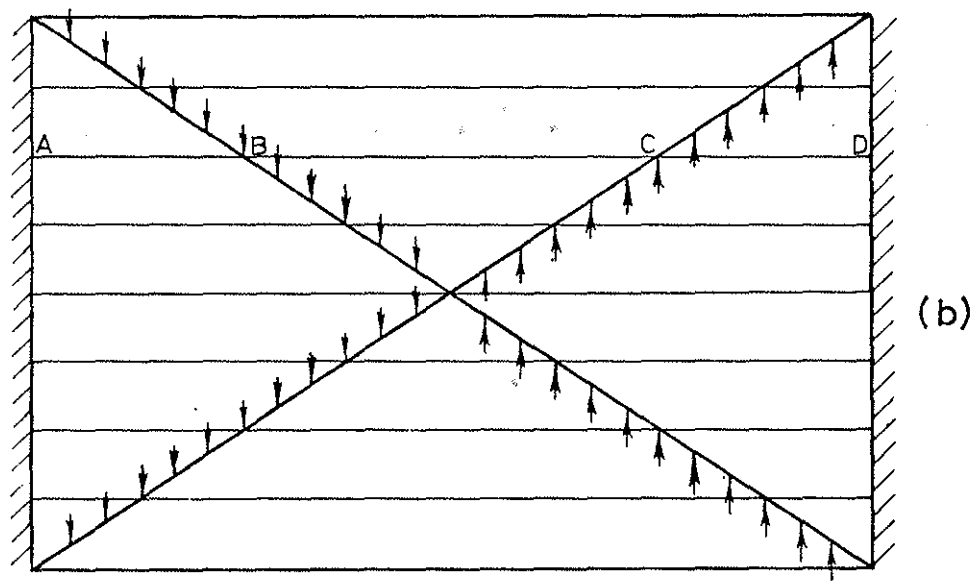
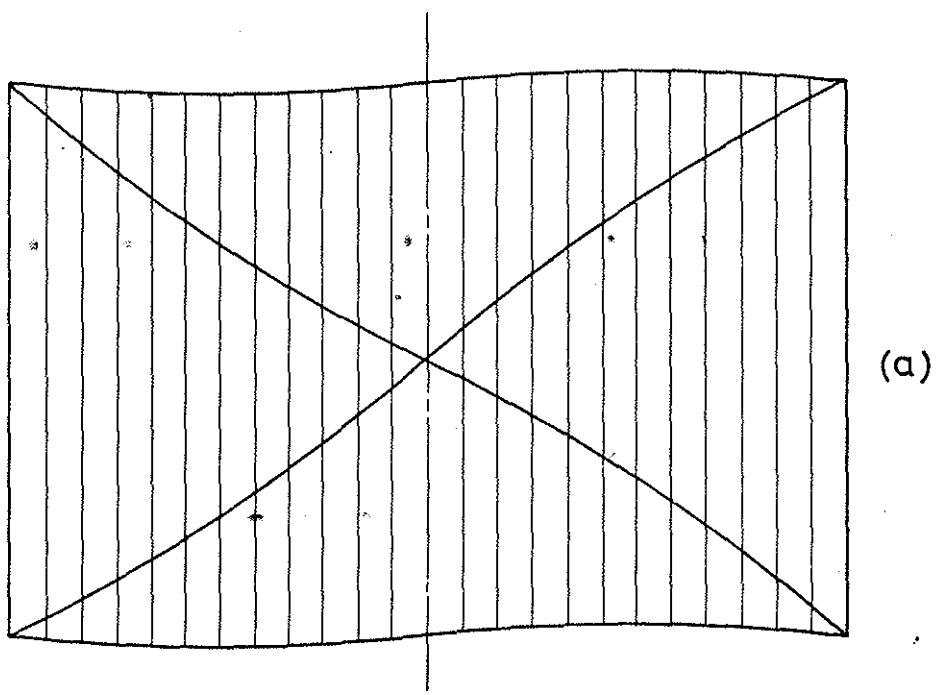

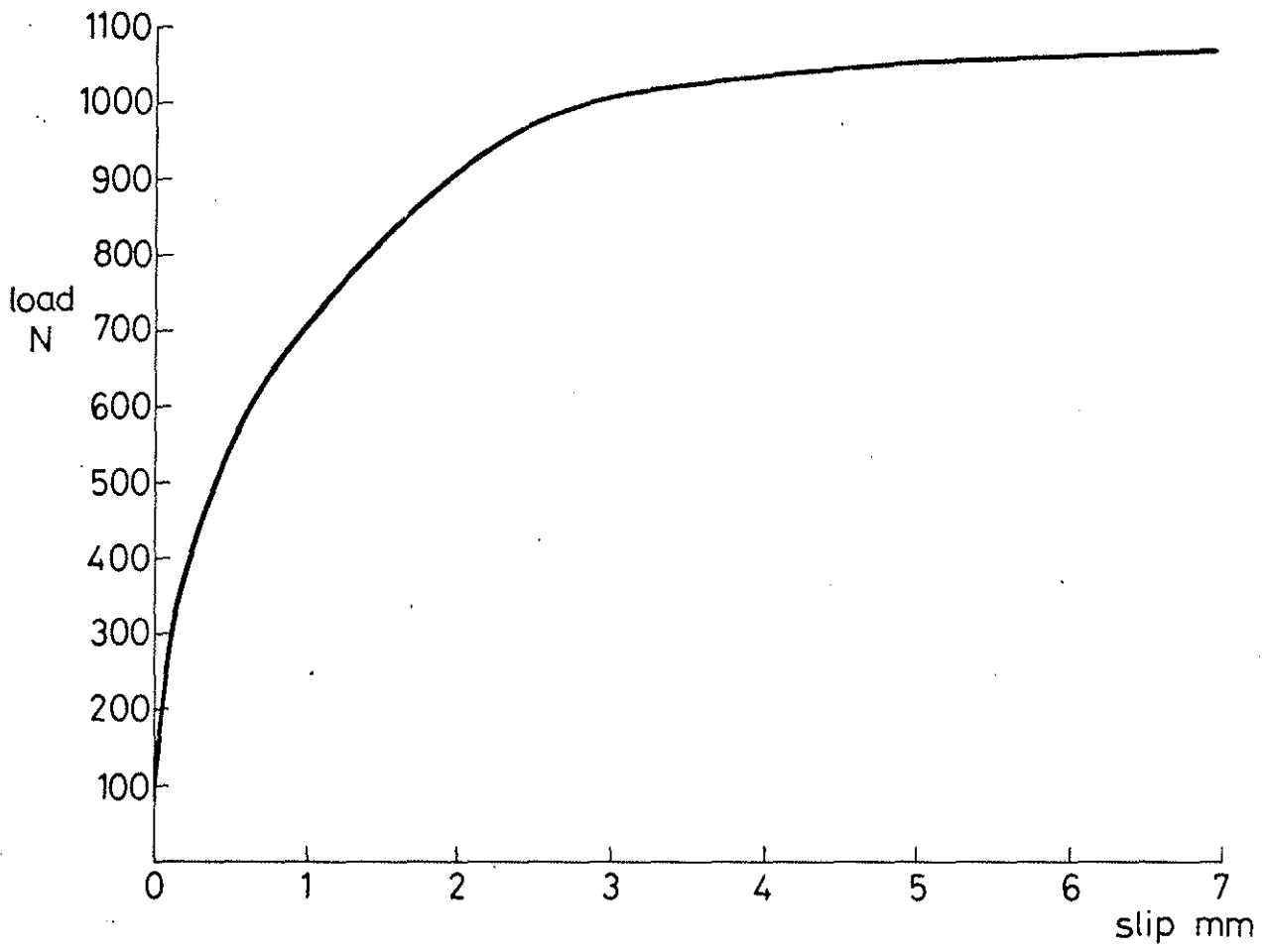

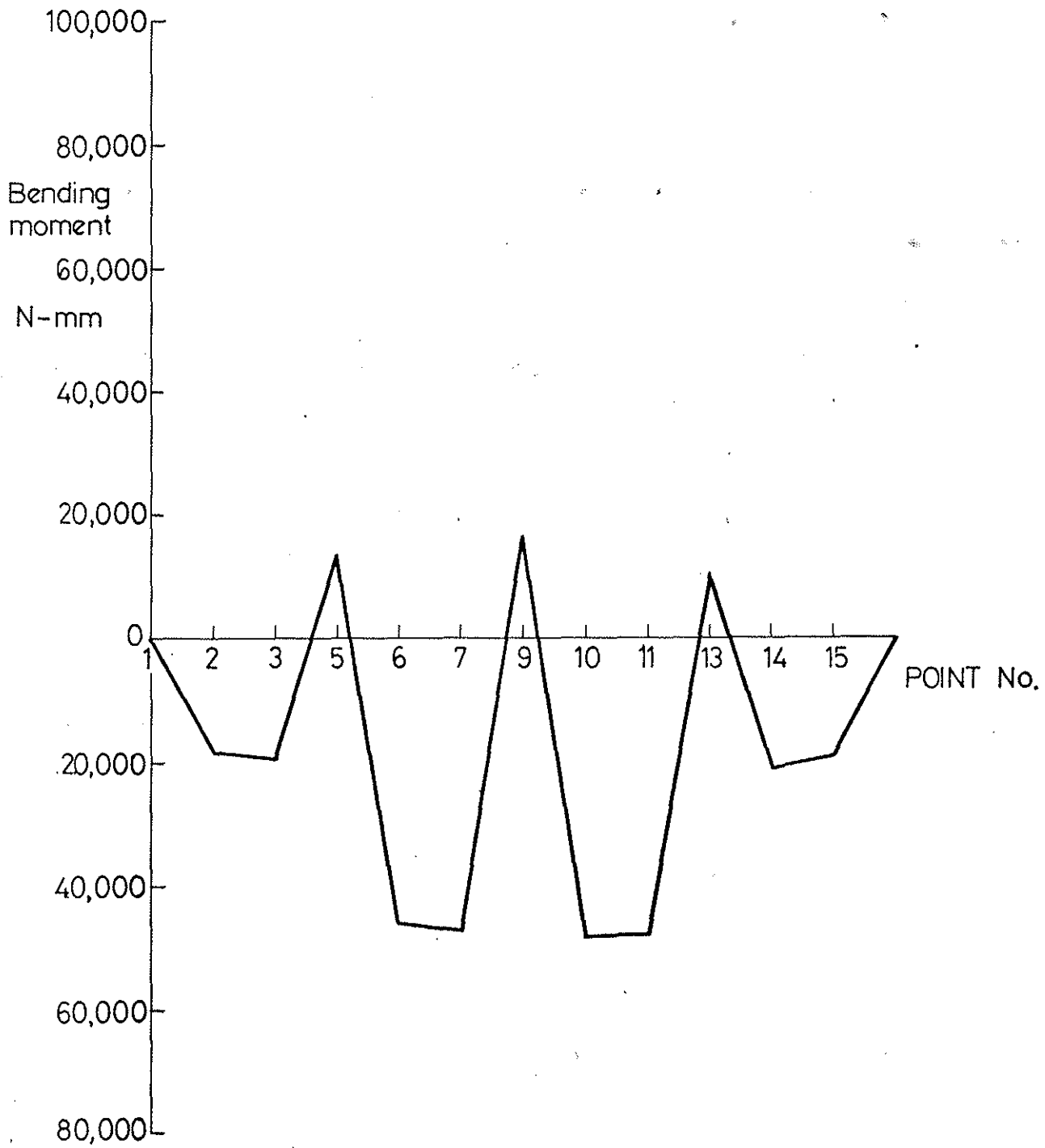

Fig. 21

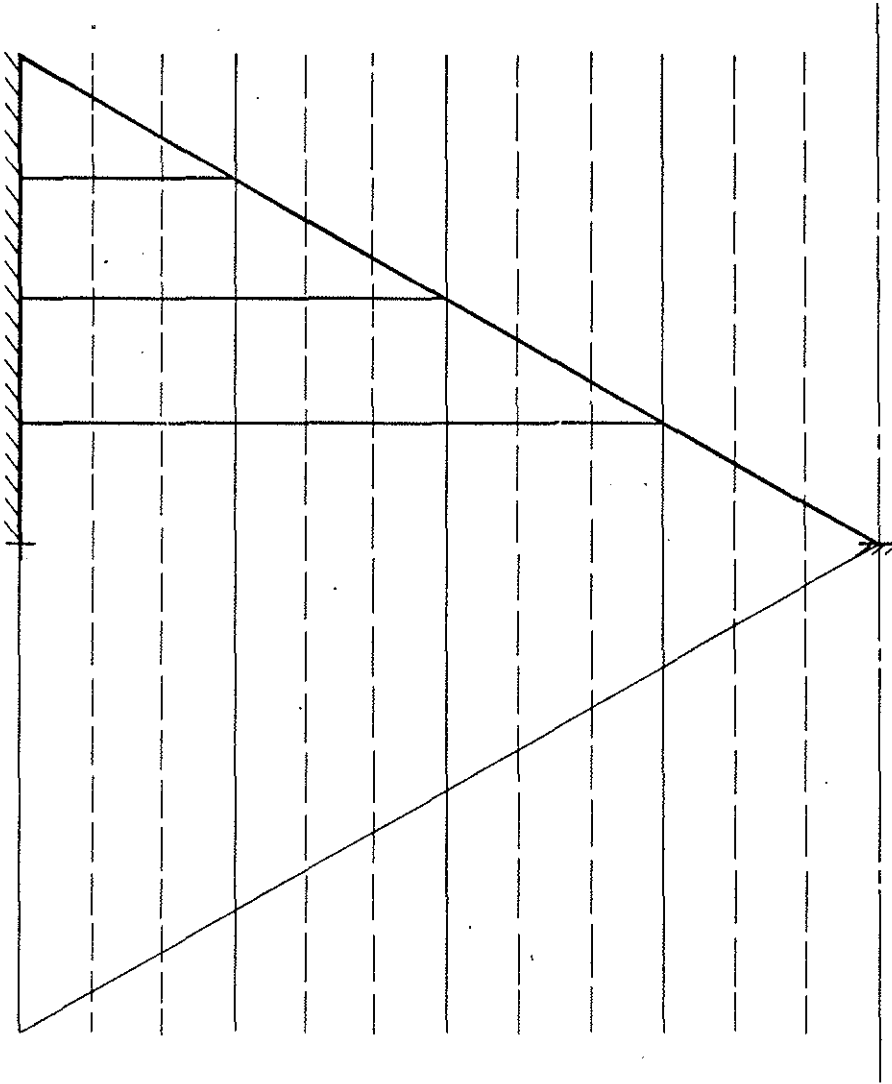
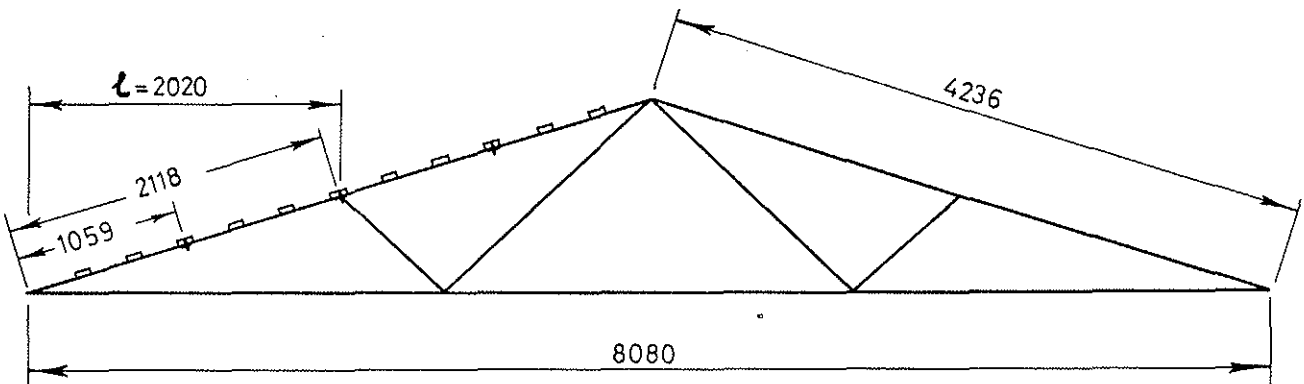

Fig. 22



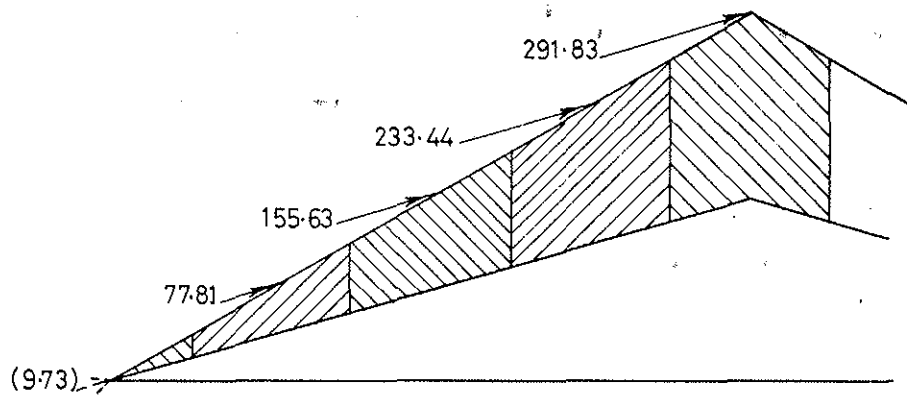

Fig. 24

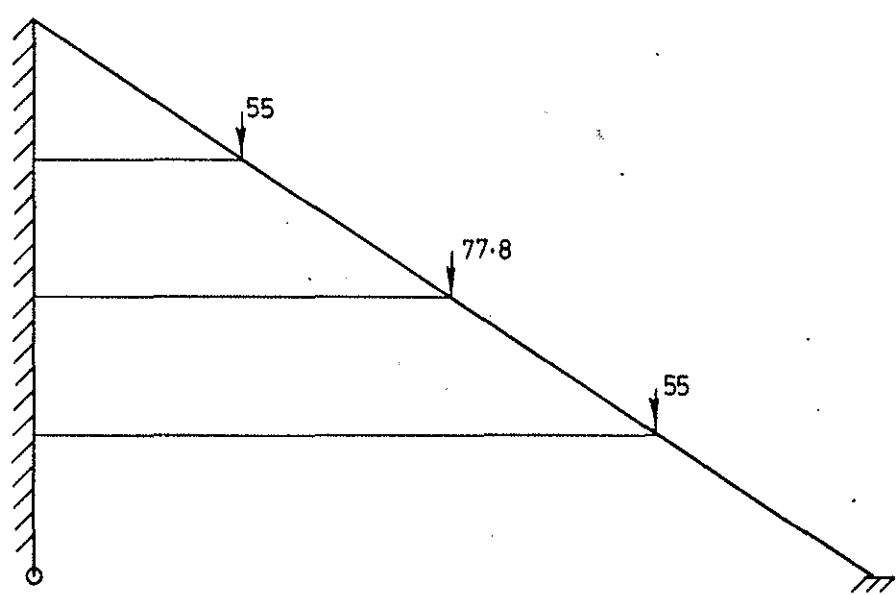

Fig. 25(a)

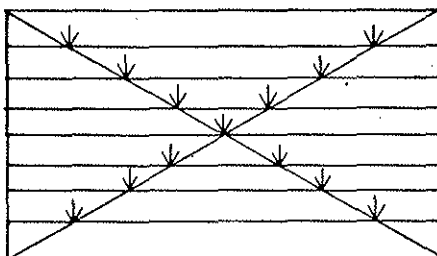
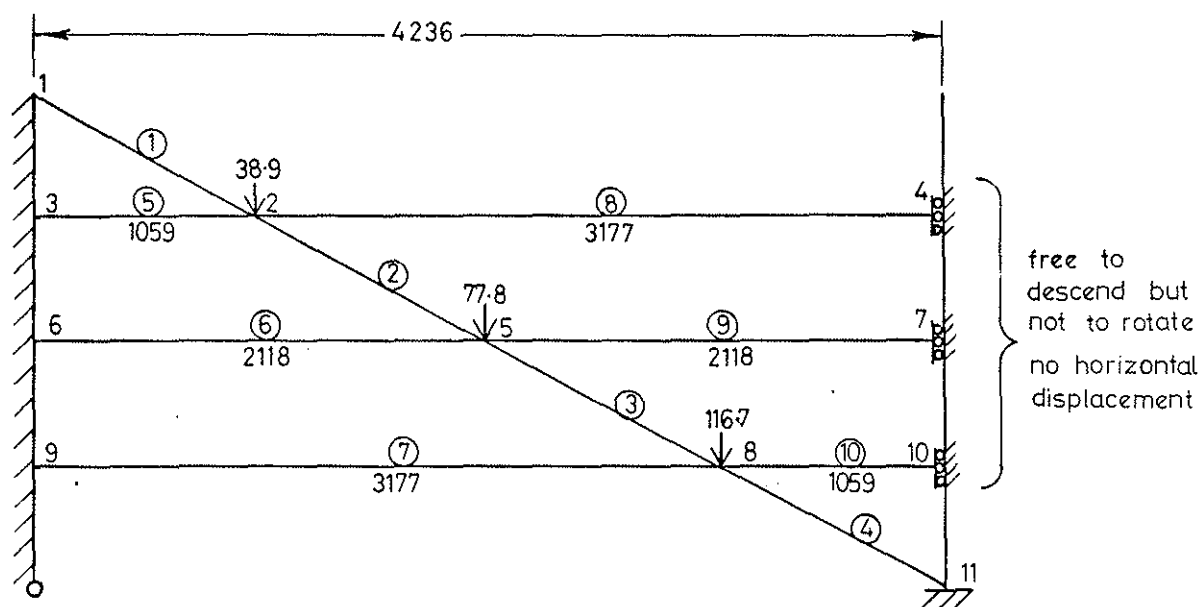

Fig. 25 (b)



6000
2000
1000

INTERNATIONAL COUNCIL FOR BUILDING RESEARCH STUDIES AND DOCUMENTATION

WORKING COMMISSION W18 - TIMBER STRUCTURES

THE DESIGN OF CONTINUOUS MEMBERS
IN TIMBER TRUSSED RAFTERS
WITH PUNCHED METAL CONNECTOR PLATES

by

P O Reece
United Kingdom

KARLSRUHE
FEDERAL REPUBLIC OF GERMANY

JUNE 1982

The design of continuous members in timber trussed rafters with punched metal connector plates

Phillip O. Reece, OBE, CEng, FStructE, MICE, MIMunE, FIWSc

Preface

When timber trussed rafters were first introduced in the UK some 16 years ago, they were constructed to span tables produced by the Princes Risborough Laboratory from a programme of tests on prototype units. The resulting roof constructions, as well as using the materials efficiently, have been shown by time to be satisfactory in service.

Since then a number of design methods have been developed in attempts to extend the scope of the tables, while retaining the efficiency of the system. These have involved calibration against the recommended spans and the introduction of 'adjustment factors' to reconcile theory with experience. The methods have not, however, been entirely satisfactory. Some have required a prohibitive data input, and all have been subject to uncertainties in the extrapolation of the 'adjustment factors' to other truss configurations and other specifications of material strength.

The quest for a general, and practical, method of design continues and, in this paper, Mr Phillip Reece has presented a new approach that merits full consideration. In it, design is concentrated on the behaviour of inter-node lengths of rafters and ceiling ties, and although developed in detail from information on trussed rafters of Fink configuration, the method can be applied generally. As is shown it has the added advantage that it can be abbreviated to a simple procedure suitable for inclusion in design guides and Codes.

W. T. CURRY
Structural Design Section
Princes Risborough Laboratory
Building Research Establishment

Synopsis

On the principle of superposition, bays of continuous members are regarded as simply supported at the node points with end-couples superimposed to simulate the effects of continuity in an indeterminate structure subjected to the simultaneous action of axial and lateral forces. From the generalised theorem of three moments elaborated by Berry¹ an expression for the maximum bending moment is derived, and this is regarded as a function of the true bending moment induced under test conditions. Similarly, an expression is derived for the moment of resistance, and this also is regarded as a function of the true moment of resistance. By determining from published span tables the ratio of the calculated bending moment to the calculated moment of resistance, factors are determined that represent the permissible bending moment per unit of moment of resistance as calculated. An additional factor is introduced limiting the longitudinal strain to a fixed proportion of the strain induced at the Euler critical load in both tension and compression.

Notation

A	is the cross-sectional area of a member or the support point at the heel of a truss (Fig 1) according to context
$a(u)$	is a Berry function (see equation (13))
B	is the node point at the first interior support from the heel joint (Fig 1)
$b(u)$	is a Berry function (see equation (13))

C	is a constant in a linear regression or the node point at the second interior support from the heel joint (Fig 1) according to context
$c(u)$	is a Berry function (see equation (13))
E	is the Code minimum value of modulus of elasticity
F	is a modification factor, a performance characteristic, the limiting value of M_B/M_r
F_1, F_2	are factors
f_a	is an actual stress in bending
f_p	is permissible stress in bending
I	is a moment of inertia or second moment of area
j	is the ratio M_C/M_B
k	is the ratio M_A/M_B
l	is the distance between node points of a member regarded as simply supported at the node points
M	is a bending moment
M_A, M_B, M_C	are bending moments at the points A, B, and C (Fig 1)
M_L	is the bending moment at midspan of a simply supported member subjected to axial force (see Fig 2)
M_M	is the positive moment at midspan of a member subjected to axial force but restrained at the ends (see Fig 2)
M_{max}	is a maximum bending moment
M_0	is the bending moment in a member with zero axial force
M_r	is the moment of resistance fZ
m	is a factor in the linear regression $y = mx + c$
N	is the ratio P_{cr}/P
P	is an axial force in tension or compression
P_{cr}	is the Euler critical load $\pi^2 EI/l^2$
P_a	is an actual axial stress P/A
P_p	is a permissible axial stress in tension or compression
u	$= \frac{l}{2} \sqrt{\frac{P}{EI}}$ (rad)
u_1, u_2	are values of u in bays 1 and 2 respectively, i.e. bays AB and BC (Fig 1)
W	is a point load
ω	is the unit intensity of uniformly distributed load
ω_1, ω_2	are values of ω in bays 1 and 2, respectively, i.e. bays AB and BC (Fig 1)
ω_c	is a uniformly distributed load producing the same maximum bending moment as a point load W
X, Y	are symbols representing combinations of Berry functions
y	is a deflection
Z	is a modulus of section

Introduction

A trussed rafter is apparently a very simple structure, but in fact it presents a complex of problems including:

- the indeterminate nature of the support system;
- the distribution of bending moments in a closed circuit of rafters and ties subjected to the combined action of bending and compression, and bending and tension;
- the continuous increase of axial stress down the length of a rafter due to incremental loading between the node points;

- the effect of combined bending and axial forces on the non-linear moment-rotation of plated joints;
- the unknown and variable eccentricity of axial loading;
- the magnitude and effect of deflection;
- the magnitude and effect of sinking supports to continuous members;
- the degree and effect of variation of strength properties along the length of a member;
- the unsatisfactory state of knowledge regarding the effect of combined axial and bending stresses in an anisotropic material;
- the unknown effect of depth factors;
- acknowledged deviations from the basic assumptions of elastic theory in terms of isotropicity, homogeneity, Hooke's Law, plane sections, etc.

The only data available that may be regarded as automatically taking into account all the considerations listed above are those to be derived from the prototype testing of trussed rafters carried out by, or under the supervision of, the Princes Risborough Laboratory. However, owing to the number of different assumptions that have to be made in current design procedures, no single assumption can be verified by reference to the observed performance of the total structure.

The problem to which this paper is addressed is that of developing a design method in which unverifiable assumptions may be replaced by a single performance characteristic.

Design is concerned with prediction, and the validity of any particular design method rests on the extent to which its predictions can be confirmed by performance. If we examine the results of a single test, a relationship may be established between a selected performance characteristic and its value as predicted by any design procedure whatever, even if totally irrational. The difficulty arises when, and if, we apply the same design procedure to other tests and find totally different relationships. The more irrational the design procedure the greater will be the variations in relationships and the greater the number and complexity of the adjustments required to secure agreement.

If performance be predicted from some assumed principle of behaviour, the difference between the predicted and observed performance will be a measure of the difference between the assumed and operative principles. More particularly, if from a theory of elastic behaviour, making no more assumptions than are required in respect of isotropicity, homogeneity, Hooke's Law, etc., we predict a specific performance characteristic, then the difference between prediction and performance will represent the cumulative effect of all the indeterminate factors involved, including inelastic behaviour and errors in assumptions.

A systematic approach on these lines presupposes some underlying order in both performance and prediction, the former requiring statistical analysis, the latter a cohesive and comprehensive theory. Individual test results are likely to appear capricious and scattered but a sufficient number of tests generally display a broad but recognisable pattern. Perfect and symmetrical order is a statistical concept rather than a natural phenomenon and an orderly array of results is achieved only by the acceptance of limits of tolerance rather than from direct observation. Such an array is provided by the published span tables and these will be used instead of selected test results to take advantage of the tolerance limits that have been determined by the Princes Risborough Laboratory and that have proved acceptable in service in the performance of some 30m trusses over a period of some 16 years. In this way, inductive reasoning from organised and proven data is given preference over deductive reasoning from what might appear to be merely self-evident or questionable axiomatic principles.

The existence of an underlying order in prediction is less easy to demonstrate as the current design method is based, not on a rigorous mathematical development of a theory of the simultaneous action of bending and axial forces, but on separate analogies of beam and column or beam and tie. In a rafter, for instance, the deflection assumed for the purpose of determining a permissible compressive stress in the member regarded as a column bears no relation whatever to the deflection effectively assumed when regarding the same member as a beam. The assumptions are inconsistent with one another, the analogies are disparate and disconnected. They cannot be deemed to represent an underlying order and, like most analogies, may have to be abandoned when pushed to the point at which they can be made to work only by increasing complication and elaboration.

It is concluded that, in developing a method of design, regard has to be paid to what are considered to be essential requirements:

- The method should within itself be rational and consistent throughout its various parts.
- The assumptions made should be consistent with one another and with such assumptions as might reasonably be made about the structure as a whole.
- Causal relationships, where not amenable to rigorous proof, should be deemed established only by very high coefficients of correlation derived from a very broad range of data.
- The method should produce results consistent with observed performance, wherever performance data may be available.
- The method should be simple for simple problems but capable of development for problems of greater complexity.

Equations

The resultant of any system of loads on a panel length in a framework may be resolved into components perpendicular and parallel to the axis of the member, the former inducing lateral bending moments M_0 , the latter contributing to the axial force P which induces an axial bending moment Py where y is the deflection. We may then say that the bending moment at any point x in a member subjected to a lateral moment M_0 and an axial force P is given by:

$$M_x = EI \frac{d^2y}{dx^2} = M_0 \pm Py \quad \dots (1)$$

where P has the positive sign in compression and negative in tension. Solutions to the differential equations for different conditions of loading are fairly well documented and proofs of the equations used will be offered in this paper only when they are not readily available in the works listed under 'Acknowledgements and references'.

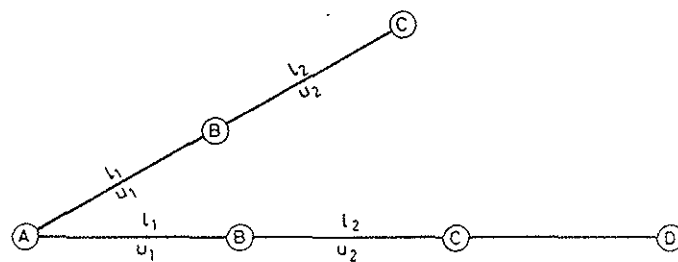

From Timoshenko⁷ we have:

- (i) For a simply supported beam subjected to axial compression and carrying a uniformly distributed load the moment M at midspan is given by:

$$M = \frac{\omega l^2}{8} \times \frac{2(1 - \cos u)}{u^2 \cos u} \quad \dots (2c)$$

- (ii) As above but carrying a centrally applied point load W :

$$M = \frac{Wl}{4} \times \frac{\tan u}{u} \quad \dots (3c)$$

- (iii) As above but subjected to end-couples M_A and M_B :

$$M = \frac{M_A + M_B}{2 \cos u} \quad \dots (4c)$$

In equation (4c) and all subsequent references, M_A refers to the moment at the plated ends of rafter and ceiling tie (heel joint), M_B to the next interior support moment, and M_C to the moment at the second interior support or terminal joint according to configuration (see Fig 1).

In bending and tension P is negative and the solutions appear in terms of hyperbolic instead of trigonometrical functions and from Pippard & Baker⁵ we may rewrite equations (2c) to (4c) as:

- (i) Uniformly distributed load:

$$M = \frac{\omega l^2}{8} \times \frac{2(\cosh u - 1)}{u^2 \cosh u} \quad \dots (2t)$$

(ii) Centrally applied point load:

$$M = \frac{Wl}{4} \times \frac{\tanh u}{u} \dots (3t)$$

(iii) End-couples M_A and M_B

$$M = \frac{M_A + M_B}{2 \cosh u} \dots (4t)$$

It will be clear from equations (2) to (4) that the midspan moment is the moment due to the lateral component M alone, multiplied by a trigonometrical or hyperbolic factor entirely dependent on the value of u which is given by:

$$u = \frac{l}{2} \sqrt{\frac{P}{EI}} = \frac{1}{2} \sqrt{\frac{Pl^2}{EI}} = \frac{\pi}{2} \sqrt{\frac{Pl^2}{\pi^2 EI}}$$

$$= \frac{\pi}{2} \sqrt{\frac{P}{P_{er}}} = \frac{\pi}{2} \sqrt{\frac{1}{N}} \dots (5)$$

where P_{er} is the Euler critical load and N is a factor expressing the ratio of the Euler load to the applied load P .

The complete solution of the problem of a continuous beam subjected to the simultaneous action of axial and lateral loading was given by Booth & Bolan in 1915. Their solution proved to be too cumbersome in form for general use and, in the following year, Arthur Berry¹ published a simplification of the method.

The notation Berry used is not thought to have the same practical advantages as that used by Timoshenko⁷ and adopted in this paper. Substituting Timoshenko's notation in Berry's equation no. 28, and rearranging the terms as suggested by Pippard & Baker⁵, we may write:

$$M_x = \frac{\omega l^2}{4u^2} - \left(\frac{\omega l^2}{4u^2} - \frac{M_A + M_B}{2} \right) \frac{\cos \frac{2ux}{l}}{\cos u}$$

$$+ \left(\frac{M_A - M_B}{2} \right) \frac{\sin \frac{2ux}{l}}{\sin u} \dots (6)$$

where M_x is the bending moment at any point x measured in the positive direction from an origin at midspan.

If we put $x = 0$ in equation (6) we have

$$M_M = \frac{\omega l^2}{4} \times \frac{1 - \cos u}{u^2 \cos u} - \frac{M_A + M_B}{2 \cos u} \dots (7)$$

where M_M is the positive moment at midspan of a continuous member.

It will be noted that the first term on the right-hand side of equation (7) is the same as equation (2c) while the second term is the same as equation (4c). It follows from this that the principle of superposition applies and that the bending moment at any point in a continuous member may be determined by regarding it as simply supported at the node points but subjected to restraining couples at A and B.

If we put M_L as the moment on the simply supported member, then the relationship between M_L , M_M , M_A , and M_B , will be as shown diagrammatically in Fig 2 (a) and (b) where

$$\left. \begin{aligned} M_L &= M_M + \frac{M_A + M_B}{2 \cos u} = M_M + \frac{(k+1)M_B}{2 \cos u} \\ M_L &= M_M + \frac{M_A + M_B}{2 \cosh u} = M_M + \frac{(k+1)M_B}{2 \cosh u} \end{aligned} \right\} \dots (8)$$

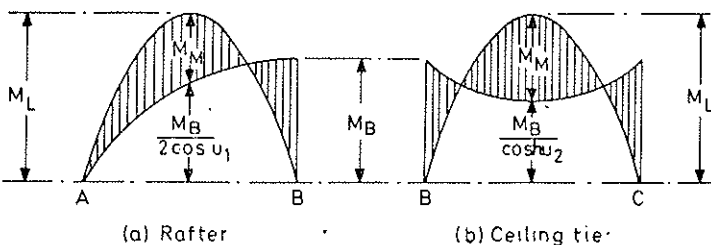

where

$$M_A = k M_B \text{ and } M_L = \frac{\omega l^2}{8} \times \frac{2(1 - \cos u)}{u^2 \cos u}$$

$$\text{or } M_L = \frac{l^2}{8} \times \frac{2(\cosh u - 1)}{u^2 \cosh u}$$

M_M is the maximum positive moment only when $M_A = M_B$ or $M_B = M_C$ as in the centre bay of a ceiling tie in a Fink truss, i.e. when $k = 1.00$. With any other value of k , Pippard & Baker⁵ show that the maximum positive moment occurs when:

$$\tan \frac{2ux}{l} = \frac{\frac{M_A - M_B}{2}}{\frac{\omega l^2}{4u^2} - \frac{M_A + M_B}{2}} \times \cot u \dots (9)$$

and

$$M_{\max} = \frac{\omega l^2}{4u^2} - \frac{\frac{\omega l^2}{4u^2} - \frac{M_A + M_B}{2}}{\cos \frac{2ux}{l} - \cos u} \dots (10)$$

As shown in Fig 1, M_A is deemed to be the moment at the heel joint and M_B the moment at the first interior support, whether rafter or tie. Now the end-restraint M_B is due to the continuity of the member over a support and can be provided only by the available moment of resistance of the section at that point. If p_a be the stress due to the axial load and p_p the permissible stress at the point of restraint, i.e. the support, then the unused part of the permissible axial stress available for conversion to a bending stress at B will be $(p_p - p_a)$. In an anisotropic material like timber we do not know what the conversion rate should be but it is possibly governed by a limiting strain. On this assumption the strain that could be added to that produced by the axial stress is $(p_p - p_a)/E_p$ where E_p is the modulus of elasticity in the axial direction. Equating this to a permissible strain in bending we have

$$\frac{p_p - p_a}{E_p} = \frac{f_a}{E_f}$$

$$\text{and } f_a = \frac{E_f}{E_p} (p_p - p_a)$$

where f_a is the corresponding bending stress and E_f the appropriate modulus of elasticity.

The Code of Practice does not differentiate between E_f and E_p but gives one value for E . If we assume that

$$E_f : E_p :: f_p : p_p$$

$$\text{then } \frac{E_f}{E_p} = \frac{f_p}{p_p}$$

$$\text{and } f_a = \frac{f_p}{p_p} (p_p - p_a)$$

This is the same as assuming that the unused portion of the axial stress bears the same relationship to the permissible axial stress as the corresponding bending stress f_a bears to the permissible bending stress, i.e.

$$\frac{p_p - p_a}{p_p} = \frac{f_a}{f_p} \text{ or } \frac{p_a}{p_p} + \frac{f_a}{f_p} = 1.00$$

$$\text{and } M_r = f_a Z = f_p Z \left(\frac{p_p - p_a}{p_p} \right) \dots (11)$$

It is emphasised that p_p is here regarded as a permissible axial stress in either compression or tension. It is the permissible stress parallel to the grain of a member of unit length, not to be confused with an end-stress derived from some assumed condition at some point in the length other than the point concerned, i.e. at the support.

Substituting for Timoshenko's⁷ notation and using the Latin alphabet in preference to the Greek, Berry's¹ equation for his generalised theorem of three moments for uniformly distributed load, constant moment of inertia, and level supports, is given by:

$$M_A l_1 a(u_1) + 2 M_B \left[l_1 b(u_1) + l_2 b(u_2) \right] + M_C l_2 a(u_2) = \frac{\omega_1 l_1^3}{4} c(u_1) + \frac{\omega_2 l_2^3}{4} c(u_2) \dots (12)$$

where the subscripts 1 and 2 in u_1, u_2, w_1, w_2 and l_1, l_2 refer to the spans AB and BC, respectively, and the values of the Berry functions $a(u), b(u)$, and $c(u)$, are given by:

In compression:

$$\left. \begin{aligned} a(u) &= \frac{3}{u} \left(\frac{1}{\sin 2u} - \frac{1}{2u} \right) \\ b(u) &= \frac{3}{2u} \left(\frac{1}{2u} - \frac{1}{\tan 2u} \right) \\ c(u) &= \frac{3(\tan u - u)}{u^3} \end{aligned} \right\} \dots (13)$$

In tension:

$$\left. \begin{aligned} a(u) &= \frac{3}{u} \left(\frac{1}{2q} - \frac{1}{\sinh 2u} \right) \\ b(u) &= \frac{3}{2u} \left(\frac{1}{\tanh 2u} - \frac{1}{2u} \right) \\ c(u) &= \frac{3(u - \tanh u)}{u^3} \end{aligned} \right\}$$

The Berry functions of equations (13) are tabulated with u (in rad) for compression in Timoshenko⁷ and for tension in Pippard & Baker⁵. Even with the use of tables, however, the calculations have proved too complicated and tedious for general adoption but after some 65 years of comparative neglect, experience now suggests this situation could be entirely changed by the advent of the modern programl w/sz calculator, let alone the extended use of computers.

Putting $M_A = kM_B$ and $M_C = jM_B$ it will be found convenient to rearrange equation (12) thus:

$$M_B = \frac{\frac{\omega_1 l_1^3}{4} \cdot c(u_1) + \frac{\omega_2 l_2^3}{4} \cdot c(u_2)}{kl_1 a(u_1) + 2 \left[l_1 b(u_1) + l_2 b(u_2) \right] + jl_2 a(u_2)} \dots (14)$$

Application

A trussed rafter is not a highly refined structure in which cross-sections are proportioned to the forces coming on them; by contrast, it is a relatively crude assemblage of prismatic members continuous through adjacent bays, the same member sustaining forces of very different magnitudes at different points along its length. The differentiation that occurs is a differentiation of stress rather than section, with the result that some sections become critical. In a continuous member the bays in which the maximum stresses occur are readily identifiable and these will be the critical bays which will be deemed to have governed the design of the member as a whole, irrespective of the number of bays the member may pass through. Extending this to a generalisation, it will be assumed that at some point or points in a structure for which a limiting span has been determined, a critical condition of stress or strain will have occurred which will have effectively determined that limiting span in the conditions in which it was established.

If, from the span tables, we calculate the axial forces on the assumption of a pin-jointed framework loaded at the node points and convert the limiting span into a distance between the node points of the most highly stressed bays, we may then consider a length of rafter or ceiling tie in isolation from the framework of which it was part and, in the light of the conclusions reached previously, may be deemed to be the length of such a

member simply supported at the node points, but subjected to calculable end-moments.

The ultimate solution of a design problem has to be sought by equating a moment of resistance to a bending moment. Equation (11), in common with other summation or interaction formulae, is a hypothesis without proof but, in applying it in the interpretation of span tables, it becomes experimental rather than axiomatic. It is not regarded as self-evident, and the most that is claimed for it is that it represents some substantial element of the true moment of resistance and that we may write:

$F_1 M_r$ = the true moment of resistance where M_r is given by equation (11) and F_1 is some unknown factor probably varying with grade and species, Poisson's ratios, moduli of elasticity, moisture content, depth, and the ratio of axial to bending stresses.

In contrast to equation (11) for the moment of resistance, equation (14) for the bending moment is supported by rigorous mathematical proof but is based on assumptions that entirely ignore the indeterminate factors given in the introduction. Following the procedure of the previous paragraph, it will be assumed that taking into account all the indeterminate factors we may write:

$F_2 M_B$ = the true moment at B

and therefore

$$\begin{aligned} F_1 M_r &= F_2 M_B \\ \text{or } F &= \frac{F_1}{F_2} = \frac{M_B}{M_r} \dots (15) \end{aligned}$$

From equation (15) it will be seen that although F_1 may be a miscellany of elastic constants and F_2 a miscellany of incalculable factors, F_1/F_2 or F is unequivocally the ratio of a calculable M_B to a calculable M_r . F is then a factor that, if derived from a known limiting span, represents the permissible limit of calculated bending moment per unit of calculated moment of resistance for a given section and that may be regarded as the single performance characteristic envisaged previously.

The use of the theorem of three moments in either Berry's generalised form or Clapeyron's leaves the residual problem of determining the terminal moment at a plated joint. Work currently in hand at Strathclyde University should throw some light on this, but in the absence of reliable data on the moment-rotation of plated joints it is necessary to follow some alternative approach. From a study of Mayo's⁴ paper on long-term performance tests, it may be concluded that, because of sinking supports over a long period of time, there is a slow but continuous transfer of moment from the intermediate supports to the endplates. It seems unlikely that the moment of resistance of the plated joint will attain 100 % efficiency, i.e. equal to the moment of resistance of the section, and in view of the possibility that the rate of transfer may determine the useful life of the structure it is here decided to treat the end-moment as one of the many indeterminacies listed in the introduction and reflected in derived values of F .

If, from equations (11), (14), and (15), we write:

$$F = \frac{M_B}{M_r} = \frac{\frac{\omega_1 l_1^3}{4} \cdot c(u_1) + \frac{\omega_2 l_2^3}{4} \cdot c(u_2)}{kl_1 a(u_1) + 2 \left[l_1 b(u_1) + l_2 b(u_2) \right] + jl_2 a(u_2)} \cdot \frac{1}{f_p Z \left(\frac{p - p_a}{p_p} \right)}$$

then for any given values of f_p, Z and p_p (i.e. for any given grade and section), F is some function of ω, l , and p_a . But M_B itself is a function of ω, l , and p_a , and the analysis of span tables has therefore been directed towards checking the validity of the hypothesis that F may be expressed as a regular and consistent function of M_B calculated for slopes of trusses from 15° to 35°.

If we consider the rafter of a Fink truss with zero axial load, we have a symmetrical arrangement with plated joints at A and C and continuous over a centre support at B, loaded only with the lateral component of the uniformly distributed load. If, for the purposes of illustrating a principle, we assume the rigidity of the plated end-joints to be equal, we may write:

$$M_A = M_C = kM_B$$

Substituting this notation in equation (14) and putting $\omega_1 l_1 = \omega_2 l_2 = \omega l$ and $j = k$ we have:

$$M_B = \frac{\left[\frac{\omega l^2}{4} c(u_1) + c(u_2) \right]}{k \left[a(u_1) + a(u_2) \right] + 2 \left[b(u_1) + b(u_2) \right]}$$

$$= \frac{\frac{\omega l^2}{4} \left[\frac{c(u_1) + c(u_2)}{a(u_1) + a(u_2)} \right]}{k + 2 \left[\frac{b(u_1) + b(u_2)}{a(u_1) + a(u_2)} \right]}$$

or $M_B = \frac{\frac{\omega l^2}{4} \cdot X}{k + Y}$

where X and Y represent the Berry functions for any particular condition of axial loading.

From equations (15) and (16) we may now write:

$$F = \frac{M_B}{M_r} = \frac{\frac{\omega l^2}{4} \cdot X}{M_r (k + Y)}$$

or

$$\frac{\frac{\omega l^2}{4} \cdot X}{F \cdot M_r (k + Y)} = 1$$

In any given limiting span $\frac{\omega l^2}{4}$, X , M_r and Y are known, fixed, and invariable. If we accept that k varies because of the sinking support at B then, as the left-hand side of the equation equals unity, F and k are related variables, i.e. for any particular value of k there is a corresponding value of F . It is concluded from this that, although their absolute values may not be of enduring significance, their specific relationship is. If, therefore, a standard value be adopted for k , the corresponding value of F will be a valid criterion, provided it is used only in conjunction with the standard value of k from which it was derived originally. The only standard value of k that will automatically ensure that the sum of the moments at the heel joint A shall be zero is when $k = 0$ and this value has been adopted in the derivation of moments. This is not to say that the moment at A is necessarily zero at any particular time; it merely asserts that, on the assumption that $k = 0$ the corresponding value of M_B/M_r is a valid criterion of the performance of a given section.

In the analysis of rafter spans, from equations (11), (14), (15), and (2c) and (8), values of M_r , M_B , F , M_{M1} and M_t have been calculated for each of 14 sections of M50 and M75 at nine different slopes from 15° to 35° in 2.5° increments, putting $k = j = 0$. The relationship between F and M_B has been treated as a linear regression, although a straight line is not necessarily the best fit. The plot of F against M_B suggests that a better fit could be achieved by curves concave upwards, flattening out as the sections increase in size but a linear regression has been adopted not only for simplicity but also because the errors involved are very small compared with inevitable experimental errors and to ensure that any extension or extrapolation beyond the known data will be on the side of safety.

Putting $F = mM_B + C$ values of m and C calculated from span tables are given in Table 1, together with their coefficients of correlation. It will be noted that the correlation improves as the sections get larger. It is also to be noted that the maximum errors are all negative and all occur at the minimum slope of 15° where the apparent curve of F values slopes sharply upwards above the regression line. The correlation coefficients for M75 38 x 75 and 50 x 75 are necessarily suspect. Nevertheless, if the figures for the 15° slope are ignored, the mean errors for the remainder are only 1.90% and 1.38%, respectively.

The procedure described in the previous paragraph has been followed in the preparation of Table 2 for ceiling ties with the necessary adjustments for taking into account the point load which was omitted from the rafters. The point load raises two special problems:

—The Berry equations refer to distributed loading

—Owing to the lack of headroom in the end bay of a Fink truss the maximum axial stress and maximum bending stress due to the point load, do not occur in the same bay.

The point load is dealt with by substituting a uniformly distributed load producing the same bending moment, thus:

From equation (2t)

$$M = \frac{\omega l^2}{8} \cdot \frac{2(\cosh u - 1)}{u^2 \cosh u}$$

From equation (3t)

$$M = \frac{Wl}{4} \cdot \frac{\tanh u}{u}$$

TABLE 1—Rafters

Values of m and C in $F = mM_B + C$

Section (mm)	m 10 ⁻³	C	Corr. coeff.	Errors %		u_1 Mean
				Max.	Mean	
M50						
38 x 75	2.1404	1.0566	0.9241	5.68	2.09	1.0049
38 x 100	1.2964	0.7504	0.9640	4.06	1.55	0.8864
38 x 125	0.8871	0.6151	0.9718	3.85	1.43	0.8193
38 x 150	0.6279	0.5250	0.9793	3.43	1.31	0.7719
50 x 75	1.7326	0.8497	0.9613	4.13	1.52	1.0470
50 x 100	1.0969	0.5681	0.9825	3.42	1.25	0.9278
50 x 125	0.7797	0.4116	0.9914	2.81	1.01	0.8417
M75						
38 x 75	-0.3315	1.5815	-0.2206	6.24	2.38	1.1270
38 x 100	0.5676	0.7078	0.8782	3.49	1.33	0.9589
38 x 125	0.4931	0.4849	0.9732	2.28	0.84	0.8622
38 x 150	0.4520	0.3016	0.9913	2.28	0.84	0.8044
50 x 75	-0.1308	1.2387	-0.1317	4.84	1.77	1.0983
50 x 100	0.5556	0.4936	0.9556	2.66	1.01	0.9564
50 x 125	0.4422	0.3411	0.9839	2.24	0.84	0.8781

u_1 mean = 0.9275

TABLE 2—Ceiling ties

Values of m and C in $F = mM_B + C$

Section (mm)	m 10 ⁻³	C	Corr. coeff.	Errors %		u_1 Mean
				Max.	Mean	
M50						
38 x 75	3.2309	0.4241	0.9977	2.32	0.71	0.9302
38 x 100	1.8305	0.3427	0.9981	1.19	0.69	0.9504
38 x 125	1.2946	0.2488	0.9996	1.10	0.39	0.9456
38 x 150	0.9338	0.1808	0.9997	0.52	0.28	0.8871
50 x 75	2.5642	0.2834	0.9994	1.32	0.44	1.0025
50 x 100	1.4816	0.2001	0.9997	0.99	0.32	0.9903
50 x 125	1.0120	0.1378	0.9999	0.47	0.21	0.9542
50 x 150	0.7332	0.0806	1.0000	0.32	0.14	0.9134
M75						
38 x 75	1.7022	0.4149	0.9931	1.95	0.71	1.0856
38 x 100	0.9806	0.3478	0.9943	1.94	0.71	1.1285
38 x 125	0.7130	0.2592	0.9943	2.18	0.81	1.1208
50 x 75	1.4553	0.2846	0.9980	1.35	0.47	1.1952
50 x 100	0.8761	0.1942	0.9990	1.24	0.44	1.1829
50 x 125	0.4413	0.2467	0.9972	0.49	0.27	1.0827

u_1 mean = 1.0264

If ω_c be the equivalent uniformly distributed load, then

$$\frac{\omega_c l^2}{8} = \frac{2(\cosh u - 1)}{u^2 \cosh u} = \frac{Wl}{4} \cdot \frac{\tanh u}{u}$$

and

$$\omega_c = \frac{W}{l} \cdot \frac{u \sinh u}{\cosh u - 1} \dots (18)$$

By symmetry, we may put $M_A = M_D = kM_B = 0$ and $M_B = M_C = jM_B$ where j is unity. Putting $\omega_2 = \omega_1 + \omega_c$ we may insert appropriate values in equation (14) and determine values for M_r , M_B , F , etc., as described earlier.

It is to be noted that the correlation of M_B and F is much better and more consistent for the ceiling ties of Table 2 than for the rafters of Table 1. Again, it is to be noted that in all but three out of the 14 cases the maximum error occurs at the 15° slope and in these cases the errors are all less than 0.50 %.

Design

In considering the implications of the factor N in equation (5) Robertson's⁶ remark that the Euler load is not strictly a collapsing load, has particular relevance; it is, on the contrary, a particular end-load which will maintain the stability of a long, slender strut in a state of neutral equilibrium in various circumstances. It is here regarded as a load producing a particular state of strain whether in compression or tension, a definitive yardstick by which to measure the performance of members in which the ideal circumstances of symmetry, homogeneity, elasticity, etc., are not necessarily realised.

Although N is not a load factor in the ordinary sense of the term, regarded as a limit for acceptable strain it would seem to be an equally valid criterion. If 2.50 be regarded as a suitable minimum load factor in the Code, it would not seem unreasonable to adopt the same figure for a limiting strain. In such a case the upper limit for u would be given by:

$$u = \frac{\pi}{2} \sqrt{\frac{1}{2.5}} = 0.9935$$

As will be seen from Tables 1 and 2 the mean value for rafters is 0.9275 and for ceiling ties 1.0264. The difference is probably attributable to one or both of two causes:

- a significant difference between the true values of E in tension and compression, here assumed to be the same;
- the fact that axial force increases the bending moment in compression but reduces it in tension.

The direct effect of u on bending moment is ignored in the current Code of Practice, yet it is marked and significant. In a rafter, for example, it may be shown from equation (2c) that the 'free' bending moment of $\omega l^2/8$ should be increased by 70 % when $u = 1.00$. If the value of u be raised to 1.10, the increase is 99 %. In tension the effect of u will produce a slight reduction in moment but u is a measure (in rad) of an angular deformation and as such is an element of deflection that may be controlled at source.

Although probably conservative, for the purposes of this paper, it is proposed to adopt upper limits for u of 1.00 in rafters and 1.10 in ceiling ties. It is acknowledged that, if adopted generally, this would involve some curtailment of span tables for all 75 mm rafters and a significant proportion of M75 ceiling ties.

In equation (15), if F be the limiting value of M_B/M_r , it is by definition the maximum permissible calculated bending moment per unit of calculated moment of resistance for a given section in a service condition when both M_B and M_r are subjected to the same axial force.

F is then a physical property that may be determined by experiment. It is a *sine qua non* of research that any physical property or constant determined by testing will be conditioned by the nature of the test itself. In applying a value for F determined by a particular experiment, we have to consider whether the experiment simulates in any appropriate degree the likely conditions in service. In acknowledging this, it must also be remembered that what we are seeking is a limiting value for moment rotation per unit of the moment of resistance of a given section; in this sense, we are not so concerned with how the moment may be induced but with a measure of its intensity.

The kind of test we require is one in which a limiting length may be

determined for a given section when subjected to known lateral and axial loads with all the indeterminacies associated with a trussed rafter, whether listed in the introduction or not. We cannot test a single member in isolation from its environment in a truss, and the possible variations of truss configuration are without limit. In such circumstances, an appropriate course of action would appear to be to determine the limit of acceptability by reference to a standard test procedure and define that limit by a single criterion, F , which is then capable of verification by testing in any particular design.

The only reliable performance data available are those derived from the prototype testing of Fink trusses. If we regard the Fink as a piece of experimental equipment designed to apply a very wide range of lateral and axial forces to the continuous members, we will have taken some account of the indeterminacies given in the introduction.

The factor F as derived from the span tables for Fink trusses is presented as a property of a section expressed as a function of an applied moment. If we apply it to other configurations then, irrespective of changes in M_B , the ratio of M_B to M_r will be the same as in a Fink truss designed in accordance with the limiting span tables. If some margin of safety higher (or lower) than is given by the standard Fink is required, this may be achieved by lowering (or raising) the limiting value of F by the required margin.

The main difference between one configuration of truss and another lies in the different distribution and magnitude of bending moments. This problem is made easier by the fact that the moment at any point is the moment that would occur with zero axial load multiplied by a trigonometrical or hyperbolic factor determined independently.

It is to be noted that equation (14) is a valid statement in itself, and if we can assign values to k and j there will be no need to get involved with a large number of simultaneous equations cluttered up with Berry functions. In a normal truss the maximum moment in a continuous rafter or tie will occur at the first interior support, i.e. M_B . Adopting the convention given in 'Application', and putting $k = 0$, the remaining problem is the determination of j . This may be decided on considerations of symmetry, as in the case of the centre bay of the ceiling tie in a Fink truss, by the use of standard tables, or calculation by any of the ordinary methods of structural analysis, e.g. Clapeyron's theorem, slope deflection, moment distribution, etc., or even by engineering judgment.

For unequal bays and unsymmetrical configurations, there is probably no alternative but to use one or other of the analytical methods referred to above and substitute in equation (14), but for the simple cases of equal loads on equal bays, and for the point load, there is scope for considerable simplification. For such cases, values of j , for the condition of equal loading on equal bays and for bay BC only loaded with the equivalent point load, may be taken from Table 3.

Tables 4 and 5 have been calculated by inserting appropriate values in equation (14) for rafters and ceiling ties, respectively. These give appropriate bending moment coefficients for 2, 3, 4, 5 and over, bays.

The key data for the Berry functions and equivalent point load used in the computation of the tables are given in Tables 6 and 7. It may be noted that although the increments between one u value and the next are sufficient to warrant some tedious interpolation, when the same functions are used in the more complex form of equation (14), as in the preparation of Tables 4 and 5, the increments are small enough to justify taking the u value as accurate to the first place of decimals only.

A further simplification is made in the adoption of a standard value of $j = 1.00$ in the case of the equivalent point load. For four bays and over a

TABLE 3

j factors for uniformly distributed loads on equal bays

where $j = M_C/M_B$

System	All bays loaded	Bay BC only loaded
2 Bay	$j = 0$	$j = 0$
3 Bay	$j = 1.00$	$j = 1.00$
4 Bay	$j = 0.6667$	$j = 1.0909$
5 Bay	$j = 0.75$	$j = 1.0976$
6 Bay	$j = 0.7273$	$j = 1.0980$
7 Bay	$j = 0.7333$	$j = 1.0981$

TABLE 4—Rafters

Bending moment coefficients n_1 for equal bays and uniformly distributed loading where
 $M_{B1} = \omega l^2/n_1$

u_1	No. of bays	u_2						
		0.50	0.60	0.70	0.80	0.90	1.00	1.10
0.50	2	7.7293	7.6674	7.5888	7.4904	7.3679	7.2145	7.0216
	3	9.7637	9.7690	9.7754	9.7825	9.7910	9.8002	9.8102
	4	9.0856	9.0685	9.0456	9.0185	8.9833	8.9383	8.8807
	5+	9.2551	9.2436	9.2287	9.2095	9.1852	9.1538	9.1131
0.60	2	7.6674	7.6084	7.5335	7.4396	7.3224	7.1752	6.9893
	3	9.6506	9.6856	9.6682	9.6795	9.6931	9.7087	9.7267
	4	8.9895	8.9752	8.9567	8.9329	8.9029	8.8642	8.8142
	5+	9.1548	9.1460	9.1346	9.1195	9.1005	9.0753	9.0423
0.70	2	7.5888	7.5335	7.4632	7.3748	7.2641	7.1245	6.9474
	3	9.5081	9.5192	9.5328	9.5490	9.5688	9.5921	9.6197
	4	8.8683	8.8573	8.8430	8.8243	8.8006	8.7695	8.7290
	5+	9.0283	9.0228	9.0154	9.0055	8.9927	8.9752	8.9517
0.80	2	7.4904	7.4396	7.3748	7.2931	7.1903	7.0599	6.8937
	3	9.3308	9.3455	9.3637	9.3856	9.4126	9.4449	9.4841
	4	8.7174	8.7102	8.7007	8.6881	8.6719	8.6499	8.6207
	5+	8.8707	8.8691	8.8665	8.8625	8.8571	8.8487	8.8365
0.90	2	7.3679	7.3224	7.2641	7.1903	7.0970	7.9779	6.8249
	3	9.1114	9.1301	9.1534	9.1818	9.2169	9.2596	9.3122
	4	8.5303	8.5276	8.5236	8.5179	8.5130	8.4990	8.4831
	5+	8.6756	8.6782	8.6811	8.6839	8.6869	8.6892	8.6904
1.00	2	7.2145	7.1752	7.1245	7.0599	6.9779	6.8724	6.7355
	3	8.8389	8.8619	8.8906	8.9260	8.9701	9.0244	9.0922
	4	8.2975	8.2996	8.3019	8.3040	8.3060	8.3071	8.3066
	5+	8.4328	8.4402	8.4491	8.4595	8.4721	8.4864	8.5030
1.10	2	7.0216	6.9893	6.9474	6.8937	6.8249	6.7355	6.6180
	3	8.4990	8.5262	8.5604	8.6029	8.6563	8.7229	8.8073
	4	8.0065	8.0139	8.0227	8.0333	8.0459	8.0605	8.0776
	5+	8.1297	8.1419	8.1571	8.1756	8.1985	8.2261	8.2600

more accurate value is 1.10, but the ultimate difference is very small, (about 2.5 %) and on the side of safety. For practical purposes the advantage of putting $M_B = M_C$ is considerable as it avoids using the complex equations (9) and (10).

Tables 8 and 9 have been prepared on this basis, and it is to be noted that, although the point load has not been applied to rafters, provision has been made for this in Table 8.

Equation (11) assumes that the support moment M_B is the maximum moment on the section, i.e. it is not exceeded by either M_M or the M_{max} of equation (10). This is regarded as an objective of design insofar as it makes provision for the inevitable sinking of the support B and the consequent transfer of moment to other parts of the same section. M_B , as determined from the span tables, is consistently greater than M_M , the ratio M_M/M_B reaching its maximum value of 0.9856 in an M50 38 x 75 mm ceiling tie with point loading on the middle bay at a slope of 15°.

The span tables limit continuity in rafters to two bays and ceiling ties to three. For continuity over four equal bays and over, the bending moment coefficient for M_B remains more or less constant, but with unequal bays and unequal loading it is possible for M_B to be reduced while the 'free' moment of equation (2) may remain constant or actually increase. From equations (8) and (14) it may be shown that, for any given values of k and j , the ratio M_M/M_B varies with u . It may therefore be stated as a limiting condition that M_M shall not exceed M_B as the ratio M_M/M_B may be varied at will by changing the section and consequently the value of u .

Recommendations

The following recommendations apply to the design of timber rafters and ceiling ties plated together at a heel joint and continuous over one or more interior supports provided by the web framing of the truss.

The critical conditions that may be deemed to determine a limiting span

for any grade and size of timber are the axial forces in the first and second interior bays from the heel joint and the included support moment M_B (see Fig 1).

For the purposes of these recommendations, members should be deemed to be simply supported at the node points and axial forces in tension and compression should be calculated on the assumption of a pin-jointed framework loaded at the node points. For the purposes of calculating axial forces, the point load should be applied at the first interior node point of the ceiling tie, i.e. point B in Fig 1.

Design stresses should not exceed those laid down in the appendices of BS 5268: Part 2, the modulus of elasticity being the minimum value specified. In addition to the permissible stresses, upper limits are set for the values of u and F hereinafter described, and also for the ratio M_M/M_B .

The value of u (in rad) should be calculated from the formula:

$$u = \frac{l}{2} \sqrt{\frac{P}{EI}}$$

The value of M_B should be deemed to be the sum of the moments M_{B1} and M_{B2} where M_{B1} is due to the uniformly distributed load and M_{B2} due to the point load when applied. M_{B1} should be calculated from the formula:

$$M_{B1} = \frac{w_1 l_1^3}{4} \cdot C(u_1) + \frac{\omega_2 l_2^3}{4} \cdot C(u_2) \\ 2 [l_1 b(u_1) + l_2 b(u_2)] + j l_2 a(u_2)$$

All symbols used are as defined in the notation. The quantity $j = M_C/M_B$ may be taken from appropriate tables or calculated by any of the normal

TABLE 5—Ceiling ties

Bending moment coefficients n_2 for equal bays and uniformly distributed loading where $M_{B1} = \omega l^2/n_2$

u_1	No. of bays	u_2						
		0.50	0.60	0.70	0.80	0.90	1.00	1.10
0.50	2	8.2631	8.3189	8.3813	8.4488	8.5203	8.5944	8.6691
	3	10.2308	10.2347	10.2390	10.2430	10.2472	10.2512	10.2541
	4	9.5749	9.5961	9.6198	9.6450	9.6716	9.6989	9.7258
	5+	9.7388	9.7558	9.7746	9.7945	9.8155	9.8370	9.8579
0.60	2	8.3189	8.3770	8.4419	8.5123	8.5869	8.6644	8.7425
	3	10.3251	10.3310	10.3375	10.3440	10.3507	10.3575	10.3632
	4	9.6564	9.6797	9.7057	9.7334	9.7628	9.7931	9.8230
	5+	9.8235	9.8425	9.8636	9.8861	9.9098	9.9342	9.9580
0.70	2	8.3813	8.4419	8.5098	8.5834	8.6616	8.7430	8.8251
	3	10.4310	10.4392	10.4484	10.4577	10.4675	10.4774	10.4865
	4	9.7478	9.7735	9.8022	9.8329	9.8655	9.8993	9.9327
	5+	9.9186	9.9399	9.9637	9.9831	10.0160	10.0438	10.0712
0.80	2	8.4488	8.5123	8.5834	8.6607	8.7430	8.8286	8.9153
	3	10.5462	10.5570	10.5691	10.5816	10.5950	10.6086	10.6216
	4	9.8471	9.8754	9.9072	9.9413	9.9776	10.0153	10.0528
	5+	10.0219	10.0458	10.0727	10.1014	10.1320	10.1640	10.1950
0.90	2	8.5203	8.5869	8.6616	8.7430	8.8296	8.9201	9.0118
	3	10.6690	10.6827	10.6981	10.7142	10.7315	10.7493	10.7665
	4	9.9528	9.9841	10.0193	10.0571	10.0975	10.1396	10.1816
	5+	10.1318	10.1587	10.1890	10.2214	10.2560	10.2920	10.3279
1.00	2	8.5944	8.6644	8.7430	8.8286	8.9201	9.0157	9.1129
	3	10.7971	10.8140	10.8329	10.8531	10.8747	10.8971	10.9191
	4	10.0629	10.0974	10.1363	10.1783	10.2231	10.2699	10.3170
	5+	10.2464	10.2766	10.3105	10.3470	10.3860	10.4267	10.4675
1.10	2	8.6691	8.7425	8.8251	8.9153	9.0118	9.1129	9.2158
	3	10.9275	10.9477	10.9706	10.9950	11.0212	11.0486	11.0757
	4	10.1747	10.2126	10.2554	10.3018	10.3514	10.4033	10.4557
	5+	10.3629	10.3964	10.4342	10.4751	10.5188	10.5646	10.6107

methods of structural analysis on the assumption of zero axial force. Key values of $a(u)$, $b(u)$ and $c(u)$ are given in Tables 6 and 7.

For constant, uniformly distributed loading on equal bay lengths, the bending moment coefficients n_1 and n_2 for members continuous over 2, 3, 4, 5, and over, bays may be as given in Tables 4 and 5 for rafters and ceiling ties, respectively, where

$$M_{B1} = \omega l^2/n_1 \text{ or } \omega l^2/n_2$$

A point load may be expressed as the equivalent load uniformly distributed over the bay in which it occurs. This is assumed to be the second interior bay of the ceiling tie (BC in Fig 1). The equivalent load in bending and tension may be taken as

$$\omega_e = \frac{W}{l} \frac{u_2 \sinh u_2}{\cosh u_2 - 1}$$

TABLE 6—Key data for rafters

$$u = \frac{l}{2} \sqrt{\frac{P}{EI}}; a(u) = \frac{3}{u} \left[\frac{1}{\sin 2u} - \frac{1}{2u} \right]; b(u) = \frac{3}{2u} \left[\frac{1}{2u} - \frac{1}{\tan 2u} \right];$$

$$c(u) = \frac{3(\tan u - u)}{u^3}; \omega_e = \frac{W}{l} \times \frac{u \sin u}{1 - \cos u}; M = \frac{wl^2}{8} \times \frac{2(1 - \cos u)}{u^2 \cos u}$$

u (rad)	$a(u)$	$b(u)$	$c(u)$	$\frac{u \sin u}{1 - \cos u}$	$\frac{2(1 - \cos u)}{u^2 \cos u}$
0.50	1.1304	1.0737	1.1113	1.9582	1.1160
0.60	1.1979	1.1114	1.1686	1.9396	1.1757
0.70	1.2878	1.1610	1.2445	1.9177	1.2549
0.80	1.4078	1.2266	1.3445	1.8922	1.3604
0.90	1.5710	1.3148	1.4821	1.8631	1.5030
1.00	1.7993	1.4365	1.6722	1.8305	1.7016
1.10	2.1336	1.6124	1.9491	1.7941	1.9911

TABLE 7—Key data for ceiling ties

$$u = \frac{l}{2} \sqrt{\frac{P}{EI}}; a(u) = \frac{3}{u} \left[\frac{1}{2u} - \frac{1}{\sinh 2u} \right]; b(u) = \frac{3}{2u} \left[\frac{1}{\tanh 2u} - \frac{1}{2u} \right];$$

$$c(u) = \frac{3(u - \tanh u)}{u^3}; \omega_e = \frac{W}{l} \times \frac{u \sinh u}{\cosh u - 1}; M = \frac{wl^2}{8} \times \frac{2(\cosh u - 1)}{u^2 \cosh u}$$

u (rad)	$a(u)$	$b(u)$	$c(u)$	$\frac{u \sinh u}{\cosh u - 1}$	$\frac{2(\cosh u - 1)}{u^2 \cosh u}$
0.50	0.8945	0.9391	0.9092	2.0415	0.9054
0.60	0.8542	0.9155	0.8743	2.0596	0.8692
0.70	0.8107	0.8897	0.8364	2.0810	0.8298
0.80	0.7652	0.8625	0.7967	2.1055	0.7884
0.90	0.7189	0.8344	0.7560	2.1332	0.7462
1.00	0.6728	0.8060	0.7152	2.1640	0.7039
1.10	0.6278	0.7777	0.6751	2.1977	0.6623

Values of $u_2 \sinh u_2 / (\cosh u_2 - 1)$ are given in Table 7. For equal bay lengths the bending moment coefficient n_4 may be as given in Table 9 where $M_{B2} = Wl/n_4$.

The moment of resistance of a section should be calculated by the formula:

$$M_r = f_p Z \left[1 - \frac{p_a}{p_p} \right]$$

The limiting value of M_B / M_r for any given grade and section is given by the formula:

$$F = m M_B + C$$

where m and C are constants for the grade and section given in Tables 1 and 2 for rafters and ceiling ties, respectively. These constants are based on the assumption of zero bending moment at the heel joint A (Fig 1) and should be used only in conjunction with values of M_B calculated on the same assumption.

The moment at the middle of the length of a member should be calculated (see Fig 2):

(a) For the bottom length of a rafter AB:

$$M_M = M_L - \frac{M_B}{2 \cos u_1}$$

$$\text{where } M_L = \frac{\omega_1 l_1^2}{4} - \frac{1 - \cos u_1}{u_1^2 \cos u_1}$$

(b) For the second interior bay of a ceiling tie BC:

$$M_M = M_L - \frac{M_B}{\cosh u_2}$$

$$\text{where } M_L = (\omega_2 + \omega_c) \frac{l^2}{4} \times \frac{\cosh u_2 - 1}{u_2^2 \cosh u_2}$$

Key values of $\frac{1 - \cos u}{u^2 \cos u}$ and $\frac{\cosh u - 1}{u^2 \cosh u}$

are given in Tables 6 and 7, respectively.

The requirements of these recommendations are deemed to be satisfied when:

- u is not greater than 1.00 in rafters and 1.10 in ceiling ties
- M_B / M_r is not greater than $F = m M_B + C$
- M_M is not greater than M_B

Examples

The following stresses are used:

Grade	Rafters			Ceiling ties		
	E (10^3 N/mm ²)	f_p (N/mm ²)	p_p (N/mm ²)	E (10^3 N/mm ²)	f_p (N/mm ²)	p_p (N/mm ²)
M75	6.7	13.75	14.85	6.7	13.75	9.625
M50	5.5	9.075	9.7625	5.5	9.075	6.325

Example 1—Rafter

Specification: $P_1 = 10$ kN; $P_2 = 9$ kN; l (over two equal bays) = 2.5m
 $\omega = 720$ N/m,

Assuming u_1 should not exceed 1.00 l required = $\frac{Pl^2}{4E}$

$$M75 \text{ } l \text{ required} = \frac{10 \times 2.5^2}{4 \times 6.7} = 2.3321 \times 10^6 \text{ mm}^4$$

$$M50 \text{ } l \text{ required} = \frac{10 \times 2.5^2}{4 \times 5.5} = 2.8409 \times 10^6 \text{ mm}^4$$

TABLE 8—Point loading rafters

Bending moment coefficients n_3 for equivalent point loading where $M_{B2} = Wl/n_3$

$u_1 \backslash u_2$	0.50	0.60	0.70	0.80	0.90	1.00	1.10
0.50	9.9721	9.8263	9.6493	9.4399	9.1957	8.9118	8.5857
0.60	10.1107	9.9593	9.7757	9.5584	9.3049	9.0104	8.6720
0.70	10.2931	10.1344	9.9419	9.7142	9.4486	9.1400	8.7854
0.80	10.5342	10.3659	10.1618	9.9204	9.6386	9.3125	8.9355
0.90	10.8585	10.6772	10.4575	10.1975	9.8942	9.5420	9.1373
1.00	11.3059	11.1068	10.8654	10.5799	10.2468	9.8600	9.4157
1.10	11.9525	11.7276	11.4551	11.1326	10.7564	10.3198	9.8181

TABLE 9—Point loading ceiling ties

Bending moment coefficients n_4 for equivalent point loading where $M_{B2} = Wl/n_4$

$u_1 \backslash u_2$	0.50	0.60	0.70	0.80	0.90	1.00	1.10
0.50	9.7388	9.7558	9.7746	9.7945	9.8155	9.8370	9.8579
0.60	9.8235	9.8425	9.8636	9.8861	9.9098	9.9342	9.9580
0.70	9.9186	9.9399	9.9637	9.9891	10.0160	10.0438	10.0712
0.80	10.0219	10.0458	10.0727	10.1014	10.1320	10.1640	10.1950
0.90	10.1318	10.1587	10.1890	10.2214	10.2560	10.2920	10.3279
1.00	10.2464	10.2766	10.3105	10.3470	10.3860	10.4267	10.4675
1.10	10.3629	10.3964	10.4342	10.4751	10.5188	10.5646	10.6107

Available sections:

- M75 38 × 100 $I = 2.66 \times 10^6$ mm⁴
- M50 50 × 100 $I = 3.57 \times 10^6$ mm⁴

Try M75 38 × 100

$$u_1 = \frac{2.5}{2} \sqrt{\frac{10}{6.7 \times 2.66}} = 0.9363$$

$$u_2 = \frac{2.5}{2} \sqrt{\frac{9}{6.7 \times 2.66}} = 0.8883$$

$$\text{From Table 4 } M_B = \frac{\omega l^2}{n_1} = \frac{720 \times 2.5^2}{7.097} = 634 \text{ Nm}$$

$$M_r = f_p Z \left[1 - \frac{p_a}{p_p} \right] = 13.75 \times 54.9 \left[1 - \frac{10}{3.40 \times 14.85} \right] = 605 \text{ Nm}$$

$$F \text{ required} = M_B/M_r = 634/605 = 1.0479$$

$$\text{From Table 1, } F \text{ permissible} = \left[\frac{0.5676}{10^3} \times 634 \right] + 0.1078 = 1.0677$$

As F required is less than permissible, the necessary recommendation is satisfied.

$$M_M = M_L - \frac{M_B}{2 \cos u_1} = \frac{\omega l^2}{4} \frac{1 - \cos u_1}{u_1^2 \cos u_1} - \frac{M_B}{2 \cos u_1}$$

$$= \frac{720 \times 2.5^2}{4} \times \frac{1 - 0.5928}{0.9363^2 \times 0.5928} - \frac{634}{2 \times 0.5928}$$

$$= 881 - 535 = 346 \text{ Nm}$$

This is less than M_B so the section satisfies all the necessary requirements.

Try M50 x 100

$$u_1 = \frac{2.5}{2} \sqrt{\frac{10}{5.5 \times 3.57}} = 0.8921$$

$$u_2 = \frac{2.5}{2} \sqrt{\frac{9}{5.5 \times 3.57}} = 0.8463$$

$$\text{From Table 4 } M_{B1} = \frac{\omega l^2}{n_1} = \frac{720 \times 2.5^2}{7.1903} = 626 \text{ Nm}$$

$$M_r = f_p Z \left[1 - \frac{p_a}{p_p} \right] = 9.075 \times 73.7 \left[1 - \frac{10}{4.56 \times 9.7625} \right] = 519 \text{ Nm}$$

$$F \text{ required} = M_B/M_r = 626/519 = 1.2062$$

$$\text{From Table 1, } F \text{ permissible} = \left[\frac{1.0969}{10^3} \times 626 \right] + 0.5681 = 1.2548$$

As F required is less than permissible, the necessary recommendation is satisfied.

$$M_M = M_L - \frac{M_B}{2 \cos u_1} = \frac{\omega l^2}{4} \frac{1 - \cos u_1}{u_1^2 \cos u_1} - \frac{M_B}{2 \cos u_1}$$

$$= \frac{720 \times 2.5^2}{4} \times \frac{1 - 0.6278}{0.7958 \times 0.6278} - \frac{626}{2 \times 0.6278}$$

$$= 838 - 499 = 339 \text{ Nm}$$

This is less than M_B so this section also satisfies all the requirements.

Example 2—Ceiling tie

Specification: $P_1 = 12\text{kN}$; $P_2 = 10\text{kN}$; l (continuous over three equal bays) = 3 m; $\omega = 300 \text{ N/m}$ with point load on centre bay corrected for medium term stresses = 825 N.

$$\text{Assuming } u_1 \text{ should not exceed } 1.10 \text{ } l \text{ required} = \frac{P l^2}{4 E u^2}$$

$$M75 \text{ } l \text{ required} = \frac{12 \times 3^2}{4 \times 6.7 \times 1.1^2} = 3.3305 \times 10^6 \text{ mm}^4$$

$$M50 \text{ } l \text{ required} = \frac{12 \times 3^2}{4 \times 5.5 \times 1.1^2} = 4.0571 \times 10^6 \text{ mm}^4$$

Available sections:

$$M75 50 \times 100 \text{ } l = 3.57 \times 10^6 \text{ mm}^4$$

$$M50 38 \times 125 \text{ } l = 5.04 \times 10^6 \text{ mm}^4$$

Try M75 50 x 100

$$u_1 = \frac{3}{2} \sqrt{\frac{12}{6.7 \times 3.57}} = 1.0625$$

$$u_2 = \frac{3}{2} \sqrt{\frac{10}{6.7 \times 3.57}} = 0.9699$$

$$\text{From Table 5 } M_{B1} = \frac{\omega l^2}{11.0486} = \frac{300 \times 3^2}{11.0486} = 244 \text{ Nm}$$

$$\text{From Table 9 } M_{B2} = \frac{W l}{10.5646} = \frac{825 \times 3}{10.5646} = 234 \text{ Nm}$$

$$M_B = M_{B1} + M_{B2} = 478 \text{ Nm}$$

$$M_r = f_p Z \left[1 - \frac{p_a}{p_p} \right] = 13.75 \times 73.7 \left[1 - \frac{10}{4.56 \times 9.625} \right] = 782 \text{ Nm}$$

$$F \text{ required} = M_B/M_r = 478/782 = 0.6113$$

$$\text{From Table 2, } F \text{ permissible} = \left[\frac{0.8761}{10^3} \times 478 \right] + 0.1942 = 0.6130$$

As F required is less than permissible, the necessary recommendation is satisfied.

$$\omega_e = \frac{W}{l} \frac{u_2 \sinh u_2}{\cosh u_2 - 1} = \frac{825}{3} \times \frac{0.9699 \times 1.1293}{1.5084 - 1} = 592 \text{ N/m}$$

$$\text{and } \omega + \omega_e = 300 + 592 = 892 \text{ N/m}$$

$$M_M = M_L - \frac{M_B}{\cosh u_2} = (\omega + \omega_e) \frac{l^2}{4} \frac{\cosh u_2 - 1}{u_2^2 \cosh u_2} - \frac{M_B}{\cosh u_2}$$

$$= \frac{892 \times 3^2}{4} \times \frac{1.5084 - 1}{0.9699^2 \times 1.5084} - \frac{478}{1.5084}$$

$$= 719 - 317 = 402 \text{ Nm}$$

This is less than M_B so the section satisfies all the requirements.

Try M50 38 x 25

$$u_1 = \frac{3}{2} \sqrt{\frac{12}{5.5 \times 5.04}} = 0.9869$$

$$u_2 = \frac{3}{2} \sqrt{\frac{10}{5.5 \times 5.04}} = 0.9009$$

$$\text{From Table 5 } M_{B1} = \frac{\omega l^2}{10.8747} = \frac{300 \times 3^2}{10.8747} = 248 \text{ Nm}$$

$$\text{From Table 9 } M_{B2} = \frac{W l}{10.386} = \frac{825 \times 3}{10.386} = 238 \text{ Nm}$$

$$M_{B1} + M_{B2} = 486 \text{ Nm}$$

$$M_r = f_p Z \left[1 - \frac{p_a}{p_p} \right] = 9.075 \times 84 \left[1 - \frac{10}{4.2 \times 6.325} \right] = 475 \text{ Nm}$$

$$F \text{ required} = M_B/M_r = 486/475 = 1.0232$$

$$\text{From Table 2, } F \text{ permissible} = \left[\frac{1.2946}{10^3} \times 486 \right] + 0.2488 = 0.8780$$

The value of F required is greater than the permissible value for the section and does not therefore satisfy the requirements.

Acknowledgements and references

1. Berry, A.: *Calculation of stresses in aeroplane wing spans*, London, The Royal Aeronautical Society, 1919
2. Cross & Morgan: *Continuous frames of reinforced concrete*, John Wiley & Sons Inc.; London, Chapman & Hall Ltd., 1932
3. Euler, L.: *Elastic curves*, translation by Oldfather, Ellis & Brown, Urbana, Illinois, 1932
4. Mayo, A. P.: *Long-term performance tests on trussed rafters*, Princes Risborough Laboratory, Building Research Establishment, 1980
5. Pippard & Baker: *The analysis of engineering structures*, London, Edward Arnold & Co., 1936
6. Robertson, A.: 'The strength of struts', *Selected engineering paper no. 28*, ICE, 1925
7. Timoshenko, S.: *Theory of elastic stability*, New York and London, McGraw-Hill, 1936

Paper: Reece

Acknowledgements and references

1. Berry, A.: *Calculation of stresses in aeroplane wing spans*, London, The Royal Aeronautical Society, 1919
2. Cross & Morgan: *Continuous frames of reinforced concrete*, John Wiley & Sons Inc.; London, Chapman & Hall Ltd., 1932
3. Euler, L.: *Elastic curves*, translation by Oldfather, Ellis & Brown, Urbana, Illinois, 1932
4. Mayo, A. P.: *Long-term performance tests on trussed rafters*, Princes Risborough Laboratory, Building Research Establishment, 1980
5. Pippard & Baker: *The analysis of engineering structures*, London, Edward Arnold & Co., 1936
6. Robertson, A.: 'The strength of struts', *Selected engineering paper no. 28*, ICE, 1925
7. Timoshenko, S.: *Theory of elastic stability*, New York and London, McGraw-Hill, 1936

Paper: Reece

Acknowledgements and references

1. Berry, A.: *Calculation of stresses in aeroplane wing spans*, London, The Royal Aeronautical Society, 1919
2. Cross & Morgan: *Continuous frames of reinforced concrete*, John Wiley & Sons Inc.; London, Chapman & Hall Ltd., 1932
3. Euler, L.: *Elastic curves*, translation by Oldfather, Ellis & Brown, Urbana, Illinois, 1932
4. Mayo, A. P.: *Long-term performance tests on trussed rafters*, Princes Risborough Laboratory, Building Research Establishment, 1980
5. Pippard & Baker: *The analysis of engineering structures*, London, Edward Arnold & Co., 1936
6. Robertson, A.: 'The strength of struts', *Selected engineering paper no. 28*, ICE, 1925
7. Timoshenko, S.: *Theory of elastic stability*, New York and London, McGraw-Hill, 1936

Paper: Reece

Acknowledgements and references

1. Berry, A.: *Calculation of stresses in aeroplane wing spans*, London, The Royal Aeronautical Society, 1919
2. Cross & Morgan: *Continuous frames of reinforced concrete*, John Wiley & Sons Inc.; London, Chapman & Hall Ltd., 1932
3. Euler, L.: *Elastic curves*, translation by Oldfather, Ellis & Brown, Urbana, Illinois, 1932
4. Mayo, A. P.: *Long-term performance tests on trussed rafters*, Princes Risborough Laboratory, Building Research Establishment, 1980
5. Pippard & Baker: *The analysis of engineering structures*, London, Edward Arnold & Co., 1936
6. Robertson, A.: 'The strength of struts', *Selected engineering paper no. 28*, ICE, 1925
7. Timoshenko, S.: *Theory of elastic stability*, New York and London, McGraw-Hill, 1936

Paper: Reece

Acknowledgements and references

1. Berry, A.: *Calculation of stresses in aeroplane wing spans*, London, The Royal Aeronautical Society, 1919
2. Cross & Morgan: *Continuous frames of reinforced concrete*, John Wiley & Sons Inc.; London, Chapman & Hall Ltd., 1932
3. Euler, L.: *Elastic curves*, translation by Oldfather, Ellis & Brown, Urbana, Illinois, 1932
4. Mayo, A. P.: *Long-term performance tests on trussed rafters*, Princes Risborough Laboratory, Building Research Establishment, 1980
5. Pippard & Baker: *The analysis of engineering structures*, London, Edward Arnold & Co., 1936
6. Robertson, A.: 'The strength of struts', *Selected engineering paper no. 28*, ICE, 1925
7. Timoshenko, S.: *Theory of elastic stability*, New York and London, McGraw-Hill, 1936

INTERNATIONAL COUNCIL FOR BUILDING RESEARCH STUDIES AND DOCUMENTATION

WORKING COMMISSION W18 - TIMBER STRUCTURES

A RAFTER DESIGN METHOD MATCHES U.K. TEST
RESULTS FOR TRUSSED RAFTERS

by

H J Burgess

Timber Research and Development Association
United Kingdom

KARLSRUHE
FEDERAL REPUBLIC OF GERMANY

JUNE 1982

A RAFTER DESIGN METHOD MATCHING U.K. TEST RESULTS FOR TRUSSED RAFTERS

In Figs.3 to 5 the results of U.K. prototype tests are shown by plotted crosses for the 35 mm rafter thickness and crosses in circles for the 47 mm thickness. The straight line through the origin represents the results of calculations based on the British Code of Practice CP112: 1971, Part 3 - Trussed Rafters for Roofs of Dwellings.

For the lowest rafter depths the test results agree well with the calculations but at greater section depths the plotted points diverge from the straight line, and use of the CP112 Part 3 method would give lower safety factors than for shallow sections.

The following notes extracted from an October 1980 report describe the procedure by which the curved lines are fitted to the higher plotted points in Figs.3 to 5.

DEVELOPMENT OF DESIGN METHODS

The earliest attempts to match calculated and test spans related to the composite grade and a difficulty was found in that values calculated by ordinary simple engineering methods were far below those found in tests. The calculated values could be expected to fall below test results for reasons connected with the method of test rather than the inadequacy of design methods, but nevertheless attempts were made to improve calculated spans by applying more sophisticated design methods.

Reduced moment coefficients were already available from the Truss Plate Institute, giving a simple approximate method of making some allowance for fixity at the eaves and ridge with continuity of members and sinking of intermediate supports. Fig.1 indicates the type of variations in rafter moments produced by these effects. With pinned joints and no member continuity the moments would be as shown in Fig.1 (a). With a continuous rafter, Fig.1 (b), there is no reduction in maximum moment but it now occurs at the intermediate support and this is advantageous in design since Part 3 allows a very low l/r ratio at this point together with a combined stress factor of 1.0 instead of 0.9.

With continuity at the eaves and ridge and with the intermediate support sinking to an extent calculated by Hansen's method, the rafter moments appear as in Fig.1(c). Another important effect included in this diagram is that of the eccentric action of the rafter thrust at the eaves joint, providing support for both rafter and tie. Without eccentricity the eaves moment in this example would be 21 Nm tending to increase rafter deflection instead of 201 Nm supporting it. Assuming some rotation at the top of the rafter to reduce the moment there, it is not difficult to envisage a redistribution in the moments of Fig.1 (c) as provided by the TPI recommendations or by the half-fixity provision in Part 3.

Brynildsen and Booth included allowance for the effect of joint rotation by a theoretical analysis incorporating semi-rigid elements, making possible a more accurate assessment of the mode of failure and the amount of deflection in a trussed rafter under test. Egerup made calculations and tests to establish a rational design procedure by allowing a degree of rigidity and plasticity for the ability of the joint to transmit forces and moments between members.

More recent Scandinavian work has shown an emphasis on the development of theoretical models representing semi-rigid joints by connected bars in arrangements yielding moment distributions close to those found in tests.

In the United Kingdom effort has been concentrated on large-scale series of tests on trusses of machine-graded material to establish span tables for these, together with studies to devise design methods yielding the maximum spans found in the tests. Grainger's earlier work had already shown that increasing member depth did not lead to the proportionate increase in span that would be expected from simple theory. The effect is implicit in the chart he used when deriving spans for the composite grade, shown in Fig.2. Only a small part of it could be explained by the depth factor in CP112 which is shown plotted on the same diagram. Brynildsen's work on trussed rafters led to the steeper curve also shown using the factor

$$\frac{6.3}{z^{0.14}}$$

to multiply the bending stress, but this still does not match the variation shown by Grainger's curves.

Another type of depth factor introduced by Green in 1976 was reported by Davies and Fairbairn following tests on sixty M75 trusses at Edinburgh University. Green expressed his factor as

$$\frac{7.05E}{10^3 D}$$

multiplying the compressive stress for the M50, MSS and M75 grades, and

$$\frac{7.16E}{10^4}$$

multiplying the bending stress for the M75 grade. Factors of similar appearance were put forward by Davies and Fairbairn together with factors of the type suggested by Brynildsen.

RECOMMENDED DESIGN METHOD

The curling-away of the lines for test span in the graphs of Figs. 3 to 5 is such a preponderant effect that providing for it must form an important part of a recommended design method. No theoretical model for analysis as an elastic plane frame can help in this, since the usual frame analysis excluding instability effects will always lead to straight-line graphs through the origin and it is the departure from such straight lines that is the significant effect to be examined.

In doing so, three possibilities may be mentioned:

- (1) Additional eaves joint eccentricity when deeper members are used.
- (2) Depth-effect formulae established empirically.
- (3) Lateral and torsional instability of the rafters.

The first arises from considering the consequence of elementary theory that increasing the member depth should result in a proportionate increase in span. As it does not, it should be asked what dimension of the elevation does not increase its size proportionately, to account for this deviation from the rules of structural similarity. The only such feature that can be found is the fixed size of the supporting wall plate, causing a reduced relative eccentricity of the rafter thrust in deeper members. Although this must make some contribution to the effect being sought it seems unlikely to be significant.

The empirical depth effect is a valid outcome of the study of truss performance, and has been used in practice to validate designs for acceptance by approving authorities. However it has the disadvantage of not yet forming a part of the body of accepted engineering procedures, and a theory making use of established engineering methods would be more desirable for a code of practice.

The fact that greater depth members of a given breadth depart from linear behaviour gives a strong indication that the third possibility, lateral and torsional instability, is the one that should be emphasised in developing a design method. The present design procedure assumes that the rafter is braced laterally in such a way that only the in-plane behaviour of the loaded truss need be considered. However the restraint applied by tiling battens is imperfect, partly because it is applied at the top of the rafters and cannot prevent torsional deflection and partly because the degree of fixing and the flexibility of the overall bracing system allow some lateral deflection to take place.

When a trussed rafter under test is loaded to between 2 and 2.5 times its design load, there is a deflection of perhaps 25 mm or more causing the restraining battens to tilt and partially withdraw the nails while considerable distortion and sometimes snaking occur in the rafters. It is at this stage of the test that the load factor is determined, and a design method devised to match test results must make allowance for the effects likely to arise in these conditions.

General theory for unbraced beam-column

The theory needed may be derived by combining the conclusions of two published papers, one on unbraced beam-columns and one on truss members with flexible bracing. A paper by Larsen and Theilgaard on unbraced timber beam-columns considers a member which for the purposes of the present work will be interpreted as carrying a bending moment causing deflection in the stiff direction as in a trussed rafter, together with an axial compressive force. The theory provides for initial deviations from straightness in both the elevation of the rafter and in its plan, together with an initial torsional displacement in the unloaded state.

Where displacement in the lateral (less stiff) direction is negligible, the derived equations reduce to those adopted as the basis for column design in the CIB code and in BS 5268. In their general form they provide for lateral as well as vertical deflection and for torsional rotation of intermediate cross-sections.

The theory leads to a complex expression giving acceptable combinations of bending moment and compressive force, and Larsen & Theilgaard point out that this would be too complicated for ordinary engineering practice. They give specimen diagrams of a type that would simplify the calculations and go on to present two simple approximate formulae of which the one expressed as follows in CP112 symbols has been selected as the basis of the work below:

$$\frac{f_a}{f_p} + \frac{c_a}{c'_p} = 1$$

where f_a = applied bending stress

f_p = permissible bending stress

c_a = applied compressive stress

c'_p = permissible compressive stress limited by simultaneous bending in both stiff and weak directions together with torsional deflection, with the value given by the following expression:

$$c'_p = \left[1 - \left(1 - \frac{c_{py}}{c_s} \right) \left(1 - \frac{c_{py}}{c_{ey}} \right) \frac{c_{ey}}{c_{ex}} \right] c_{py}$$

in which c_{py} = permissible compressive stress for buckling in the weak direction

c_s = permissible compressive stress for a very short column

c_{ex} = Euler stress for buckling in the strong direction

c_{ey} = Euler stress for buckling in the weak direction

For a rectangular section with greater dimension d and smaller dimension b ,

$$\frac{c_{ey}}{c_{ex}} = \frac{b^2}{d^2}$$

It is found that for the range of cross-sections used for trussed rafters the expression in square brackets does not differ greatly from unity, so c'_p may be approximated by c_{py} and the design equation proposed for limiting the combination of bending and compressive stresses will be based on the modified expression

$$\frac{f_a}{f_p} + \frac{c_a}{c_{py}} = 1$$

with the value of c_{py} adjusted to allow for the effect of lateral bracing.

Allowance for flexible lateral bracing

The proposal for lateral bracing is derived from a paper by Medland giving the results of computations on structures comprising up to six compression members in parallel linked by up to twelve lines of bracing. The paper examines the axial load capacity of the columns as influenced by the stiffness of the bracing, expressing the capacity in terms of the Euler load of the inter-brace length as

$$P = \rho (\pi^2 E I_y / a^2)$$

where a is the inter-brace length. Design values for ρ are given, and of course these are generally well below unity for bracing of low stiffness although they can actually exceed unity if the axial load is non-uniform because with high bracing stiffness a higher axial load is required to force the column into buckling modes which are produced more easily with uniform load.

The paper does not deal with the type of axial load distribution that occurs in trussed rafters; also brace requirements to prevent torsional buckling and the effect of eccentric bracing such as that produced by tiling battens being attached on the top of the rafters are left as topics for further study. Nevertheless useful pointers are given to assist the present investigation.

The paper suggests that if, say, torsional buckling takes place at $\rho = 0.7$ whereas lateral buckling will occur at $\rho = 1.0$, a safety factor on the 0.7 value could be taken to produce a desired working load level, usually about half the ultimate capacity. The diagrams presented in the paper could then be used to determine the brace strength requirements at that working load and the braces designed accordingly.

In trussed rafters the bracing is not designed in this way so it would not be surprising to find ρ values well below unity and such values would explain the departure of test results from calculations producing a linear variation of span with member depth. This purpose would not be served by taking a fraction of the inter-brace Euler load, since in the case of tiling battens this would remain constant with an increase of span. The effect needed would increase with increasing rafter span, so for the purpose of matching span tables with calculations a factor would have to be applied to the Euler load of the unsupported rafter length between nodes. Medland does give scope for departing from the inter-brace length as a basis in his

comparison of the analysis for a large number of discrete braces with that assuming a continuous elastic support.

What is really sought is a combination of actions in the plane of the truss and perpendicular to it, and the paper by Larsen taken in conjunction with the one by Medland gives a good indication of how this can be achieved. In the expression

$$\frac{f_a}{f_p} + \frac{c_a}{c_{py}}$$

the value of c_{py} will be found using a modified l/r ratio for the unsupported rafter length. The prototype tests on trussed rafters may be regarded as a means of determining suitable modification factors. From their results it is found that a factor of the order of 0.5 applied to the effective length will produce calculated spans varying with rafter depth in the manner indicated by test results. For close agreement in the case of 25° pitch a curve-fitting procedure yields the following values for the multiplying factor for the three different grades in the draft Part 3 span tables:

<u>25° pitch</u>	Breadth b =	35	47 mm
	M50	0.433	0.590
	SS/MSS	0.410	0.579
	M75	0.473	0.683

Comparison with span tables

A comparison of span table figures with calculated spans based on the above factors is given in Figs. 3, 4 and 5 for 25° pitch. The straight-line portion of each graph indicates where spans are governed by combined stress at the node. The curved portion shows spans governed by combined stress in the lower rafter using the design equation incorporating c_{py} calculated with the tabulated multiplying factors for effective rafter length. The 'half fixity' allowed by the present Part 3 is adopted for all three graphs.

Spans taken from the draft Part 3 span tables are shown by crosses for the 35 mm breadth and crosses in circles for 47 mm. The agreement of calculated and tabulated spans is very good except in the M75 grade where however the results may still be taken as fulfilling the objectives of the study.

Graphs are given only for 25° pitch but the method has been found applicable over the whole range of pitches for which span tables are given (15° to 35°). The exact manner of applying it will depend on whether the closest possible fit is required for all cases or whether approximate factors are adopted to cover a group of results. For example it appears from the values already given that a factor 0.43 might be thought acceptable for 35 mm and 0.59 for 47 mm, except for M75 grade where 0.47 and 0.68 could be applied.

Further work since the above notes were written has incorporated the revised permissible stress and 'E' values adopted for BS 5268. With other adjustments it has been found that a single expression can be applied to yield a multiplying factor matching the span tables approximately over the whole range of pitches and timber grades. The expression has been put forward in the following form for inclusion in the draft Part 3 of BS 5268.

Effective length (mm)

$$\text{for lateral buckling} = 0.01 brk^{\frac{1}{4}}$$

where b = breadth of rafter (mm)

r = length of bay on slope (mm)

k = $\frac{\text{distance between adjacent bracing systems}}{\text{length of bay}}$

The design method as proposed is no more complicated than that now in use. The combined stress equation for the lower rafter presents much the same appearance as the present one, which would continue to be applied for the node. The method follows established engineering principles taking advantage of recent published work, to give results in keeping with what would be expected from commonsense reasoning.

References

1. BRITISH STANDARDS INSTITUTION - Code of practice for the structural use of timber, CP112: 1971, Part 3 - Trussed rafters for roofs of dwellings, 1973.
2. TRUSS PLATE INSTITUTE - TPI-78 Design specification for metal plate connected wood trusses. Truss Plate Institute Inc., 1978.
3. HANSEN, A.T. - Deflections of wooden roof trusses based on simple joint tests. CIB report No.8 from 1965 symposium 'Modern Timber Joints'. 1967.
4. BRYNILDSEN, O.A. & L.G. BOOTH - Structural analysis of timber trusses with semi-rigid joints. IUFRO conference, Munich 1967.
5. EGERUP, A.R. - Theoretical and experimental determination of the stiffness and ultimate load of timber trusses. Report No. R62, Structural Research Laboratory, Technical University of Denmark, 1975.
6. FELDBORG, T. & M. JOHANSEN - Wood trussed rafter design: Strength and stiffness tests on joints; long-term deflection of W-trussed rafters. Report 118, The Danish Building Research Institute, 1981.
7. GRAINGER, G.D. - The development of trussed rafters in the U.K. Paper to Building Research Establishment symposium, Princes Risborough Laboratory, 1976.
8. GREEN, R.W. - Contribution to Building Research Establishment symposium, 1976.
9. DAVIES, S.R. & D.R. FAIRBAIRN - Proposal for the introduction of a modification factor to allow for different grades of timber and sectional dimensions in the design of fink trussed rafters. Paper to IUFRO wood engineering group meeting, Blokhus, Denmark, 1976.
10. LARSEN, H.J. & E. THEILGAARD - Laterally loaded timber columns. J1. Struct. Div. ASCE, July 1979.

11. CONSEIL INTERNATIONAL DU BATIMENT - CIB structural timber design code, fifth edition, August 1980.
12. BRITISH STANDARDS INSTITUTION - BS 5268, The structural use of timber, February 1982 draft of standard in preparation to replace CP112.
13. MEDLAND, I.C. - Buckling of interbraced beam systems. Eng.Struct. Vol.2, April 1980.

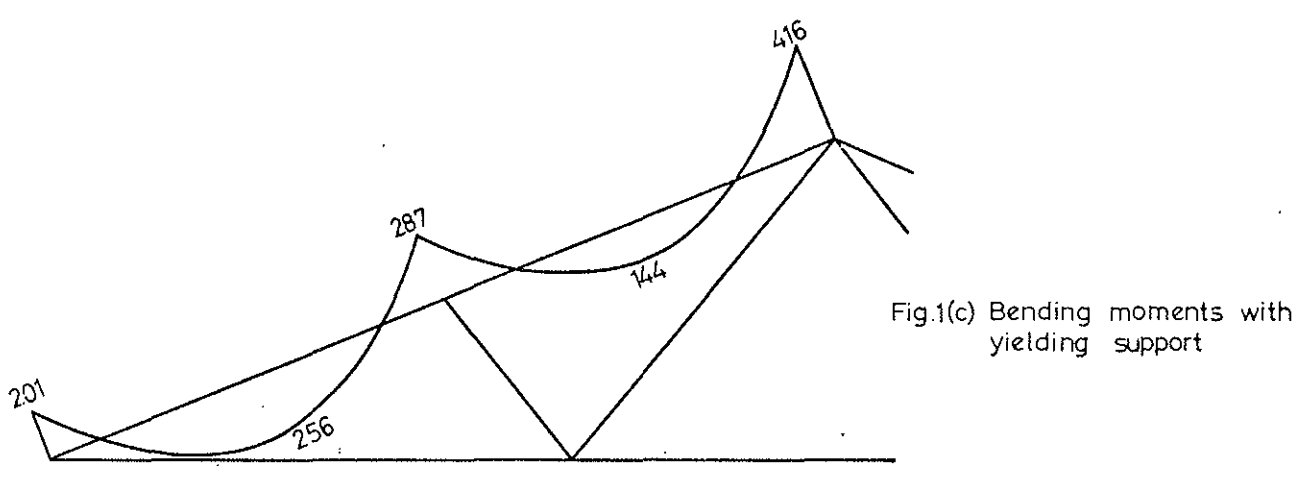
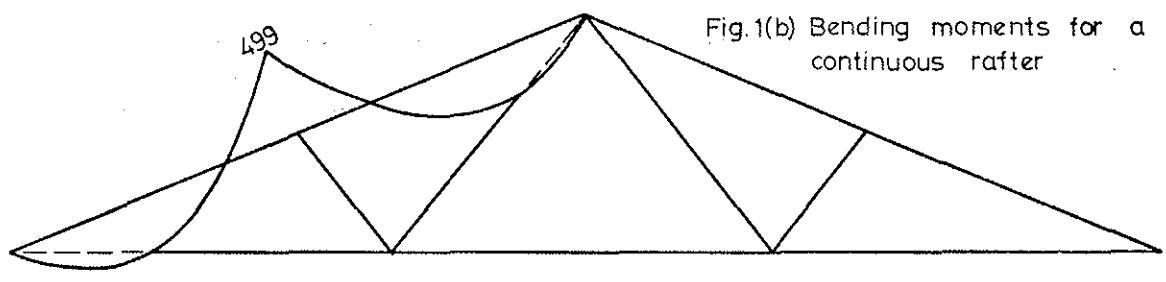
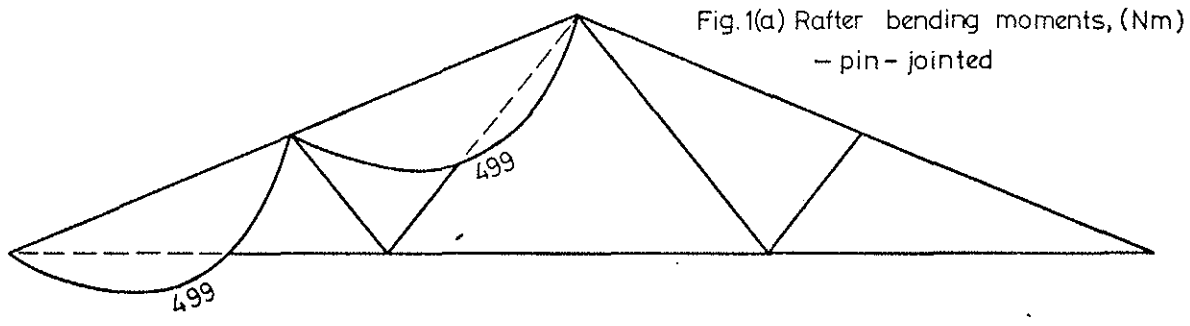

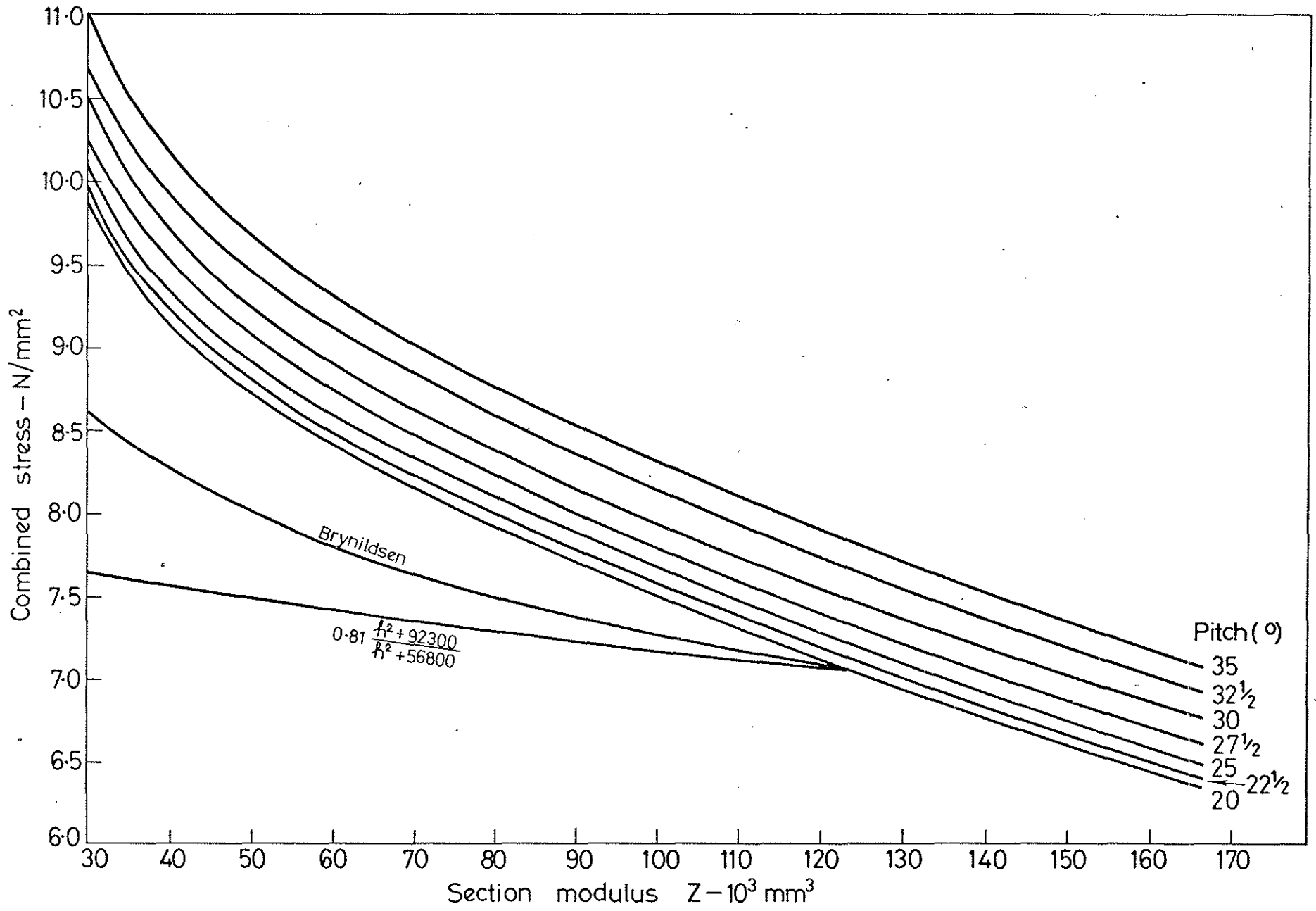

Fig. 2

Fig. 2

25° PITCH M50

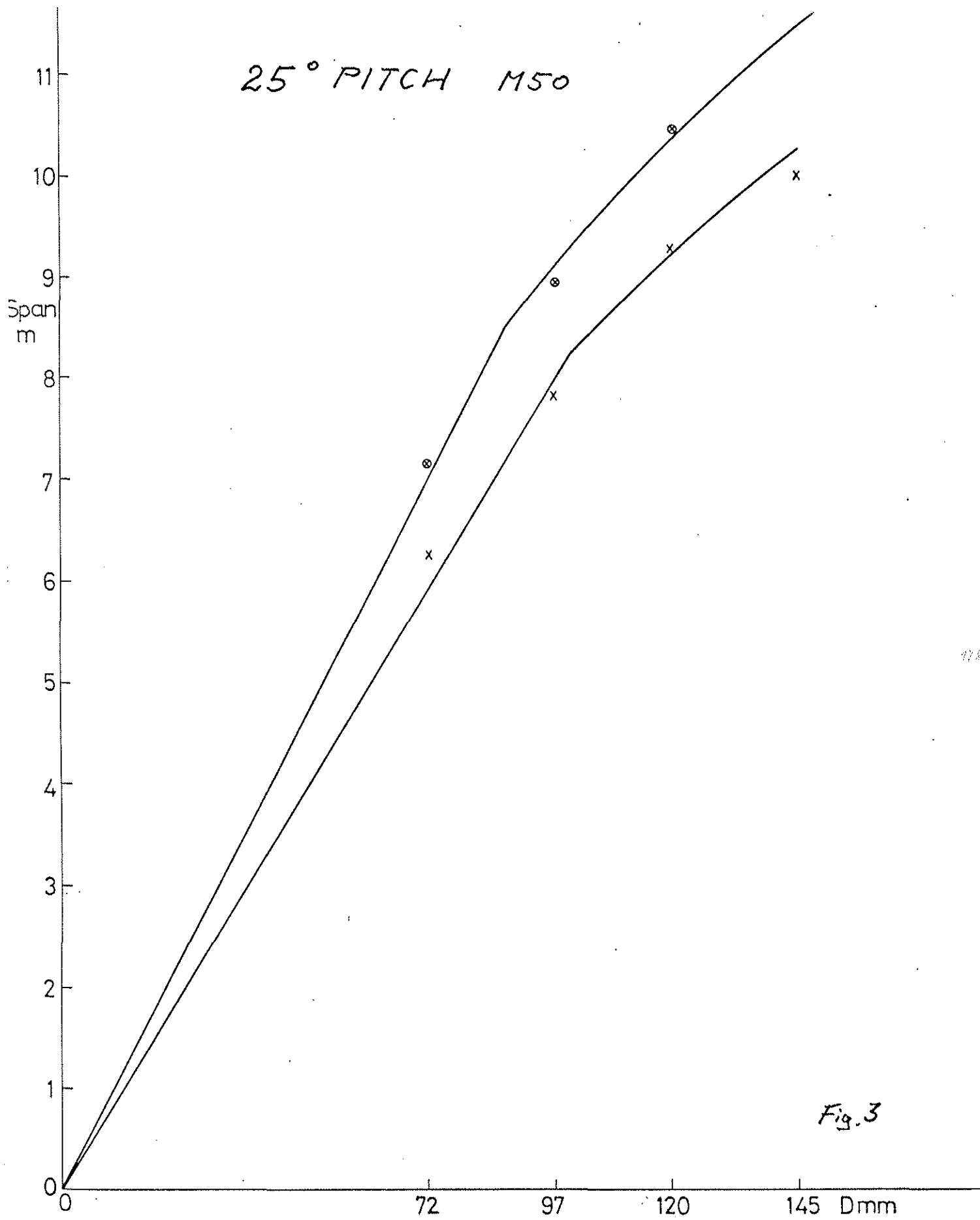

Fig. 3

25° PITCH SSIMSS

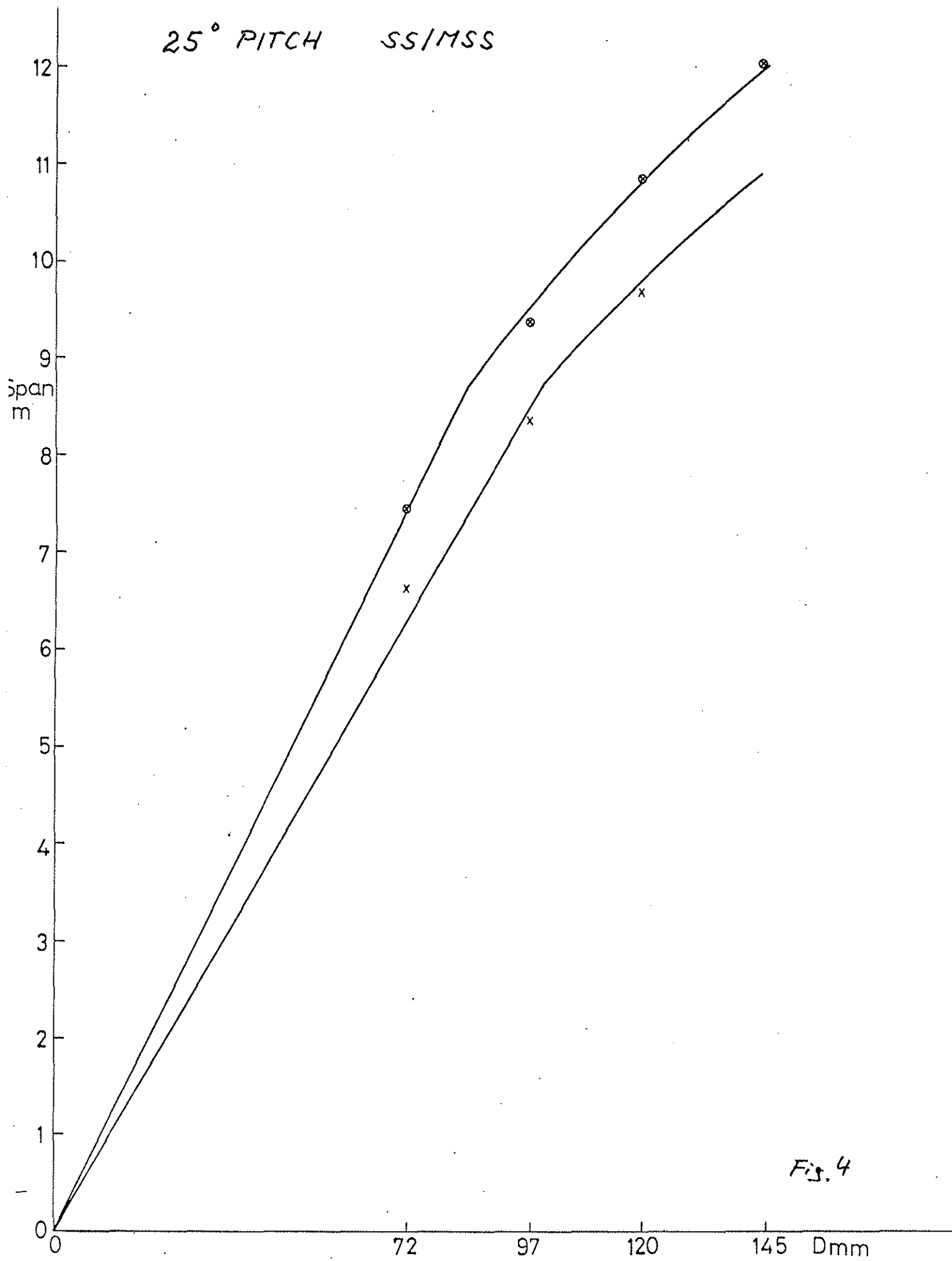

Fig. 4

25° PITCH M75

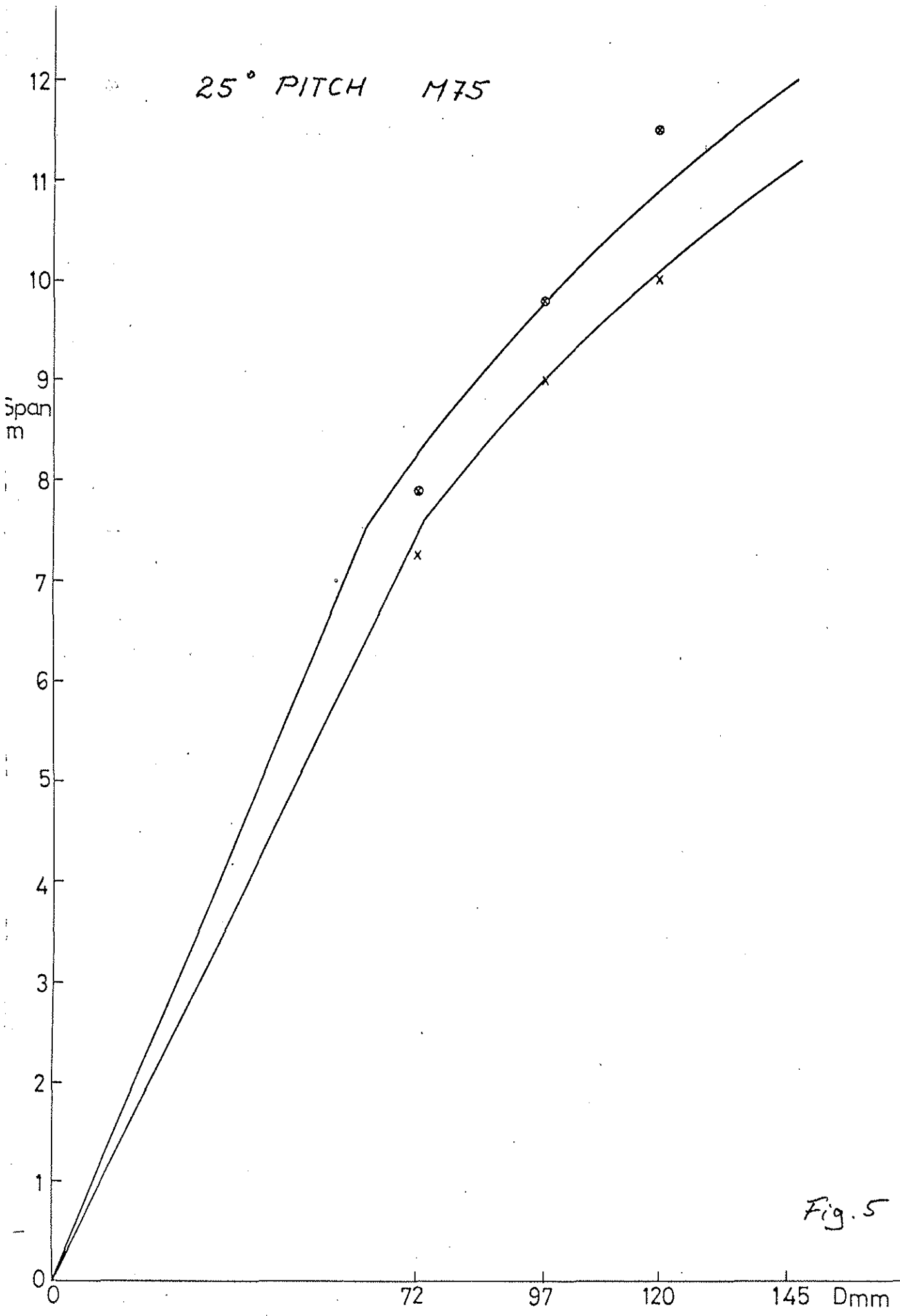

Fig. 5

INTERNATIONAL COUNCIL FOR BUILDING RESEARCH STUDIES AND DOCUMENTATION

WORKING COMMISSION W18 - TIMBER STRUCTURES

RESOLUTIONS OF TC 165-MEETING
IN ATHENS 1981-10-12/13

KARLSRUHE
FEDERAL REPUBLIC OF GERMANY
JUNE 1982



Resolutions of TC 165-meeting in Athens 1981-10-12/13

Resolution No. 15 (Athens No. 1)

The plenary session of TC 165 noted that regrettably the document DIS 6891 (Timber Structures-Joints-Determination of Strength and Deformation Characteristics of Mechanical Fasteners) had not yet been distributed by the Central Secretariat to the member countries. TC 165 expressed the hope that this document would be submitted in both English and French versions immediately.

Resolution No. 16 (Athens No. 2)

The plenary session of TC 165 asked the secretariat to produce a revised version of document N 52 (Timber structures- Solid timber in structural sizes - Determination of some physical and mechanical properties) taking into account the result of the discussion of document N 56 (Comments on document N 52).

The Secretariat was asked to send the revised version to the member bodies for comments and then prepare a DIS for combined voting.

The need was stressed for urgently including of additional test methods, particularly shear, simplified moisture content measurements and density determinations, and the secretariat was asked to produce such methods in cooperation with TC 55. The delegation of USSR expressed reservations with regard to the publication as a DIS prior to the inclusion of the additional test information.

Resolution No. 17 (Athens No. 3)

The plenary session of TC 165 received the report of WG 1, "Grouping of timber based on structural properties" and requested the convener to present a Working Paper of that group as soon as possible, so that the secretariat may distribute it for comment.

Resolution No. 18 (Athens No. 4)

The plenary session of TC 165 noted with satisfaction the formation of the joint Working Group ISO/TC 139 and TC 165 concerning testing of plywood.

It received the report of its representative on the group of the first meeting of the group, and expressed the hope that documents would soon be available for comments under the auspices of TC 139. The secretariat of TC 165 was asked to keep the members informed.

Resolution No. 19 (Athens No. 5)

The plenary session of TC 165 decided to add to the programme of work the preparation of an international standard on testing of joints with integral metal plate connectors. The secretariat was asked to prepare a first draft based on documents produced by RILEM/CIB-W18.

Resolution No. 20 (Athens No. 6)

The plenary session of TC 165 decided to add to the programme of work the preparation of an international standard on the production of glued laminated structures. The secretariat was asked to prepare a first draft based on documents produced by CEI-bois/CIB-W18.

Resolution No. 21 (Athens No. 7)

The plenary session of TC 165 decided to add to the programme of work the preparation of an international standard on testing of timber structures as an alternative to design by calculation. The secretariat was asked to prepare a first draft based on documents produced by RILEM/CIB-W18.

Resolution No. 22 (Athens No. 8)

The plenary session of TC 165 recognized the need of guidance for the protection of timber structures against biological degradation, and decided to set up a small group to review existing information and recommend to the secretariat future actions on this subject.

The group will consist of

Mr. A. Demange, France

Mr. P. Hoffmeyer, Denmark

A delegate from UK (Sunley responsible)

A delegate from Germany (Ehlbeck responsible)

The TC 165 secretariat will act as convener of the first meeting of the group.

Resolution No. 23 (Athens No. 9)

The plenary session of TC 165 decided that method No 4 of the different approaches outlined in document N 54 should as far as possible be taken as the basis for the technical content of the ISO Standards to be established by TC 165.

Resolution No. 24 (Athens No 10)

The plenary session of TC 165 asked the secretariat to reconsider the document N 55 on the basis of the comments received and the discussion during the session and in particular identify unresolved problems and submit these for further consideration by CIB/W18.

INTERNATIONAL COUNCIL FOR BUILDING RESEARCH STUDIES AND DOCUMENTATION

WORKING COMMISSION W18 - TIMBER STRUCTURES

TERMS OF REFERENCE
FOR TIMBER-FRAMED HOUSING SUB-GROUP OF CIB-W18

by

H J Larsen

Danish Building Research Institute

Hørsholm

KARLSRUHE
FEDERAL REPUBLIC OF GERMANY

JUNE 1982

TERMS OF REFERENCEFOR TIMBER-FRAMED HOUSING SUB-GROUP OF CIB-W18

To study structural design practice for timber-framed housing in the different member countries, with consideration to non-structural questions only insofar as they have an effect on structural design.

The aspects to be considered will include the following as particularly related to houses with timber-framed walls:

Roof systems: types of framing-trussed rafter spacing, other possible framing systems, bracing from internal walls, semi-bungalow construction, more complex roofs (intersections, hips and valleys); design of individual structural elements, excluding trussed rafter topics already under discussion in CIB-W18; bracing against wind forces; connections. Available standard designs, computer programs.

Floor systems: means of support; any aspects especially related to timber-framed houses in the manner of design for flooring, joists, beams and calculation methods for horizontal diaphragms. Available design aids - span tables, computer programs.

Walls: framing systems; component design-studs, horizontal members; assurance of racking resistance - test methods, calculation methods; racking data for different sheet materials. Available design aids and computer programs.

Materials: for framing, cladding and lining, and their involvement in structural action; attachment of involved materials.