

INTERNATIONAL COUNCIL FOR BUILDING RESEARCH STUDIES

AND DOCUMENTATION

WORKING COMMISSION W18 - TIMBER STRUCTURES

CIB - W18

F. Litzung

MEETING SEVEN

STOCKHOLM, SWEDEN

28 FEBRUARY/1, 2 MARCH 1977

CONTENTS

Inhaltsverzeichnis
S. 15

	Page
1 LIST OF DELEGATES	2
2 CHAIRMAN'S INTRODUCTION	4
3 CO-OPERATION WITH OTHER ORGANISATIONS	4
4 STRESS GRADING	5
5 JOINTS	6
6 PLYWOOD	8
7 GLUED-LAMINATED STRUCTURES	11
8 LOAD DURATION EFFECTS	11
9 LONG-TERM JOINT TESTS	12
10 TIMBER CODE	12
11 FIBRE BUILDING BOARDS	12
12 BRACING OF STRUTS	13
13 JOINTED BEAMS	13
X 14 TORSIONAL TESTING OF SOLID AND LAMINATED TIMBER	13
15 SWEDISH TIMBER HOUSING	13
16 NEXT MEETING	14
17 PAPERS PRESENTED AT THE MEETING	15
18 CURRENT LIST OF CIB-W18 PAPERS	16
19 ISO TECHNICAL COMMITTEES	23
20 ISO TC 165 MEMBERSHIP	
21 VOLUME ONE: COMMON UNIFIED RULES FOR DIFFERENT TYPES OF CONSTRUCTION MATERIAL	

E 102 / 77a

Standort-Nr.: LH-T217

Inv.-Nr.: E10217

Lehrstuhl für Ingenieurholzbau
und Baukonstruktionen
Universität Karlsruhe
Univ.-Prof. Dr.-Ing. H. J. Bläß

1 LIST OF DELEGATES

AUSTRIA

E Armbruster

European Federation of Building Joinery Manufacturers'
Association, Wien.

BELGIUM

L Montfort
H Riberholt
A Visser

Institute National du Logement, Brussels
Automated Building Components, Brussels
Automated Building Components, Brussels

CANADA

C R Wilson

Council of Forest Industries of British Columbia, Vancouver

DENMARK

M Johansen
H J Larsen

Statens Byggeforskningsinstitut, Horsholm
Instituttet for Bygningstekn, Aalborg

FINLAND

E Niskanen
T Rechartt
U Saarelainen

Technical University, Otaniemi
Technical Research Centre of Finland, Espoo
Technical Research Centre of Finland, Espoo

FEDERAL REPUBLIC OF GERMANY

P Frech
K Mähler
P Taylor

Otto-Graf-Institut, Stuttgart
Universität Karlsruhe, Karlsruhe
American Plywood Association, Sandwiese

NETHERLANDS

J Kuipers

Stevin Laboratory, Delft

NORWAY

P Aune
O Brynildsen
O B Kristiansen

Norges tekniske høgskole, Trondheim
Norsk Treteknisk Institutt, Oslo
Norges Byggstandardiseringsråd, Oslo

FRANCE

P E H Crubile

Centre Technique du Bois, Paris

POLAND

B Bany Centralny Osrodek Badawezo Projektowy, Warsaw
W Nozynski Centralny Osrodek Badawezo Projektowy, Warsaw

REPUBLIC OF SOUTH AFRICA

J Simon Council for Industrial and Scientific Research, Pretoria

SWEDEN

H Edlund Svenska Plywoodforeningen, Stockholm
T Englesson Swedish Forest Products Research Laboratory, Stockholm
B Johannesson Chalmers Tekniska Högskola, Göteborg
C Johansson Chalmers Tekniska Högskola, Göteborg
B Källsner Swedish Forest Products Laboratory, Stockholm
B Norén Swedish Forest Products Laboratory, Stockholm
B Robens Träinformation, Stockholm
T Schmidt Swedish Forest Products Laboratory, Stockholm
B Thunel Swedish Forest Products Laboratory, Stockholm
H Wickholm Träinformation, Stockholm

UNITED KINGDOM

L G Booth Imperial College, London
H J Burgess Timber Research and Development Association, High Wycombe
W T Curry Building Research Establishment, Princes Risborough
P Grimsdale Swedish Timber Council
R March Arup Associates, London
1) J G Sunley Timber Research and Development Association, High Wycombe
2) J R Tory Building Research Establishment, Princes Risborough
T Williams Hydro-Air International, High Wycombe

UNITED STATES OF AMERICA

D H Brown American Plywood Association, Tacoma

- 1) Chairman and Co-ordinator, CIB-W18
- 2) Technical Secretary

2 CHAIRMAN'S INTRODUCTION

The seventh meeting of the commission was opened by the chairman and co-ordinator, MR SUNLEY, who welcomed delegates to Stockholm. He pointed out that the meeting had attracted several new participants and that this meeting would be the largest yet held by the Commission. In particular he welcomed those representing American and Finnish plywood interests, the two delegates from Poland and the representative from the GLULAM sub-group of FEMIB.

3 CO-OPERATION WITH OTHER ORGANISATIONS

ISO/TC 165: PROF LARSEN reported that a preparatory ad hoc meeting of TC 165 had taken place in Copenhagen on 28 September 1976. He said that it had been agreed by the majority of members at that meeting that CIB-W18 should be entrusted with the main drafting work for TC 165. Canada had been opposed to that proposal on the grounds that CIB-W18 was too academic, and Norway had opposed on the grounds of the time that would be taken to produce drafts.

MR SUNLEY said that the drafting of international codes was expensive and the work of W18 was not financed from a central fund. He had made application to the EEC for funds to finance the timber code, he continued, and he was hopeful that EEC would eventually finance the work for ISO. The chairman concluded by saying that he hoped the work on testing joints, solid timber and plywood which were to be discussed at this meeting of W18 would very soon be ready for presentation to ISO.

PROF LARSEN said that he expected EEC to delay funds for a timber code until CEB had produced a code for concrete.

ISO/TC 55: PROF THUNEL explained that the areas of interest of this technical committee were grading and test procedures for solid timber.

The secretary, MR TORY, said that TC 55 had circulated to their members two documents (Document 74 (July 1976) and Document 75 (July 1976) on the testing of structural sized timbers.

DR KUIPERS said that he had not seen these papers but as chairman of RILEM he thought they should be taken into account by RILEM before the joint CIB/RILEM paper was published on the same subject.

ISO/TC 98: It was reported that TC 98 was soon to publish a "Bases for Design".

ISO/TC 139: PROF MOHLER and DR WILSON, both members of this technical committee concerned with plywood had nothing to report.

Secretary's note: The areas of interest of some relevant ISO technical committees and the membership of TC 165 are given elsewhere in this publication.

ECE: The chairman told the meeting that ECE were discussing the harmonisation of building regulations and the unified stress grading of timber. ECE would continue to consult CIB-W18 on matters related to structural timber he said.

IUFRO: The chairman reported that there continued to be close co-operation between CIB-W18 and IUFRO Wood Engineering Group. He reminded delegates that the next IUFRO meeting would be held in Vancouver in August 1978 and would be preceded by a symposium on fracture mechanics.

RILEM: DR KUIPERS reported that RILEM-3TT would be meeting in Stockholm immediately after W18. He hoped that they would be able to agree on the publication of CIB/RILEM documents on joints and testing of structural sized timber. Another paper on plywood testing, to be discussed later at this meeting, was also at an advanced stage, he said.

FEMIB: DR ARMBRUSTER told the meeting that he was representing the GLULAM sub-commission of FEMIB. He explained that GLULAM was an association of manufacturers representing eight European countries. The sub-commission was drafting a two-part code for glulam. The first part, said DR ARMBRUSTER, was involved with design and was nearly complete. The second part, dealing with manufacture, would be discussed at their next meeting in May 1977.

4 STRESS GRADING

MR CURRY made a statement on progress within ECE towards unified visual stress grading rules. He explained that the first draft set of rules, circulated for comment in January 1975, had adopted the knot area ratio system of grading and had made provision for two visual grades EC1 and EC2. In July 1976 the limiting knot ratios for EC1 had been relaxed from $\frac{1}{4}$ margin knot ratio, $\frac{1}{4}$ total knot ratio to $\frac{1}{2}$ margin, $\frac{1}{4}$ total. At that time too, continued Mr Curry the limits for distortion had been relaxed at the request of the North Americans. A meeting to discuss the rules was to take place in London on 7 March 1977 and he asked for the views of the delegates on the proposed grades.

PROF LARSEN spoke against the $\frac{1}{2}$, $\frac{1}{4}$ limits for EC1. He pointed out that although yields increased (compared with $\frac{1}{4}$, $\frac{1}{4}$) stresses fell. He also spoke against the EC2 limits. These were identical to the British GS grade of British Standard 4978 he said and accepted material that was unsuitable for structural use. He thought that for the ECE grades to be acceptable to the Nordic countries the lowest characteristic stress for EC2 would have to be 18 N/mm². Mr Curry's figures, said Prof Larsen, suggested stresses of 17 and 23 N/mm² for EC2 and EC1 ($\frac{1}{2}$, $\frac{1}{4}$ limits) respectively. He would like to see these raised to 18 and 24 with a third, higher grade at 30 N/mm².

MR CURRY explained that in the UK the limits for GS had been largely determined by the timber trade's requirements for low reject rates from mill outturn and commercial Vths; the same starting point for a grading system was equally applicable in ECE. He agreed that GS grade could be poor quality timber but he expected that eventually in the UK SS would be increasingly sought for structural use. A characteristic stress of 30 N/mm² for European redwood/whitewood could only be achieved by introducing a density requirement into the rules, concluded Mr Curry.

MR WILLIAMS supported the $\frac{1}{2}$, $\frac{1}{4}$ limits for EC1. The greatly increased yields, he said, would far outweigh the slight reduction in stresses.

PROF THUNEL said that the yield figures he had seen had nearly all been based on grading only for knots. He expected other defects to affect yields as much as knots and in any case, he continued, there would be substantial differences in yields between different mills. Although stress graded timber was important to engineers he said, it should not be forgotten that it only accounted for about 10 per cent of mill outturn.

PROF LARSEN did not accept that distortion was likely to significantly affect yields and he thought it unlikely that by taking into account defects other than knots increases in characteristic stresses could be achieved.

MR CURRY agreed that most of the work carried out at Princes Risborough on stresses and yields for the ECE grades had been based on results which did not include detailed information on defects other than knots. But the Data Bank at PRL was the largest single source of relevant information he added.

MR SUNLEY wound up the discussion by saying that W18 was naturally interested in these proposals now before ECE since grading was a fundamental part of structural timber

design. The number of grades had not been fixed and it might be necessary to have different grades for North America and for Europe. Mr Sunley undertook to represent W18 at the next Geneva meeting of ECE.

5 JOINTS

PROF LARSEN introduced Timber Standards 06 and 07 (parts of paper 7-100-1 Draft CIB Timber Code/Timber Standard). He drew attention to the Preface where he had admitted that the CIB-RILEM label of the standards was incorrect. In answer to DR NOREN he agreed that there were differences in content between these documents and the papers 6-7-1 and 6-7-3 that had been agreed at Aalborg (meeting 6; June 1976). Prof Larsen explained that he had attempted to translate paper 6-7-1 into the more obligatory form that would eventually be required for ISO.

DR KUIPERS said that in many respects this paper was similar to 6-7-1 though the long duration test had been omitted. RILEM he said would proceed with the publication of paper 6-7-1 in accordance with the agreement at Aalborg.

PROF LARSEN asked for written comments on Standard 07 before the end of April 1977 and he would redraft the Standard for the next meeting.

MR SUNLEY commented that he expected the Aalborg version to form the basis of a British Standard.

MR RIBERHOLT pointed out that Prof Larsen's version required displacement measured at the ultimate load and Dr Kuiper's version measured displacement at 0.4 ult load.

Paper CIB-W18 7-7-1, "Testing of Integral Nail-Plates at Timber Joints" was introduced by PROF MOHLER. This paper had originally been presented at Aalborg (meeting 6; June 1976) but because of problems with translation had not been discussed at that time. The paper was considered page by page and the following comments were made:

Section 1 PROF MOHLER asked if the paper need be confined to integral nail plates. The tests could equally well be applied to nail-through plates.

DR KUIPERS pointed out that the nail bending tests would not apply to plates with separate nails.

MR SUNLEY suggested that a note could be included in the paper requiring only relevant parts of the tests to be carried out.

Section 2 MR WILLIAMS said that a minimum thickness of 1 mm was impractical since this was nearly the upper limit of the tolerance range for the most usual plate thickness. It was agreed that this dimension should be amended to 0.91 mm.

Section 3 DR NOREN suggested that the terminology 'Permissible force' was incorrect. The aim of the tests was to produce a characteristic strength at an ultimate limit state.

PROF LARSEN said that it was unnecessary to mention the purposes of the tests.

DR NOREN disagreed saying that although they may not appear in the final

standard they should be included in CIB papers.

Section 3.C MR BRYNILDSEN would have preferred " $\alpha = 0^\circ$ and $\alpha = 90^\circ$ " to read " $0 \leq \alpha \leq 90^\circ$ ". This he said would permit calculation of the moment capacity of plates.

PROF MOHLER said that there were too many difficulties with gaps and butting ends to allow satisfactory measurement of the moment capacity of plates and in any case these would be difficult to calculate from a tensile test.

MR SUNLEY suggested that there should be an item 3e to introduce long-term testing.

PROF LARSEN pointed out that it would be difficult to decide on suitable climatic conditions for long-term tests.

Section 4.2 DR NOREN asked why corrosion proofing was included.

PROF MOHLER explained that although this would not necessarily influence the testing corrosion proofing was accepted by most countries as necessary to produce satisfactory performance.

MR WILLIAMS asked that the method of manufacture be included in the data. He said that this could significantly influence the results and if it were omitted it could make some comparisons of results meaningless.

MR AUNE suggested that section 6 of Timber Standard 06 paper 7-100-1 be copied into this paper in place of paragraph 1 of section 4.2.

MR BRYNILDSEN asked why different moisture contents were specified for testing and production.

DR KUIPERS said it should not be necessary to specify a moisture content for production.

PROF LARSEN observed that to comply with previously agreed papers climatic conditions should be defined rather than moisture content.

It was agreed that moisture content classes from the Code should be included.

MR CURRY said that it had been agreed some time ago that sampling, testing and analysis should be treated as separate topics. Paragraph 3 Section 4.2 should therefore be deleted.

PROF MOHLER, in answer to a question from MR BRYNILDSEN, explained that the last paragraph of section 4.2 was included to facilitate the comparison of results.

Section 5.1.1 MR AUNE suggested that 'determined' should be replaced by 'recorded'.

Section 5.1.2 MR WILLIAMS did not consider this test necessary. He thought it might be used to produce a measure of plate performance which would be quite unacceptable.

PROF MOHLER agreed that this test was more applicable to a production quality control procedure.

Section 5.2.1.1 a) MR AUNE said that for values of α other than 0° or 90° this would not produce a pure tension test of the plate since moments would be introduced.

MR BRYNILDSEN said that the test as it stood would be useful for testing plates cut at varying angles to the nails.

DR KUIPERS considered the test an acceptable simplification.

There followed a lengthy discussion on the size of the gap between the timber members of the test pieces. MR WILLIAMS thought a gap unnecessary while MR BRYNILDSEN thought it should be increased. It was eventually agreed to retain the 1 mm gap until it could be shown to be unsatisfactory.

Section 5.2.1.2 MR BRYNILDSEN asked that 'l' should always be greater than $0.6 b$.

PROF LARSEN thought this unnecessary since the mode of failure of the joint was more likely to be governed by the width of the plate rather than a small change in its effective length on the specimen.

Section 5.2.1.3 PROF LARSEN asked for this section to be included in a Preface.

Section 5.2.1.4 MR VISSER suggested that this section be deleted. He did not agree that compression shear joints were not allowed; only that they were not very often used.

Fig 4, 5, 6 MR WILLIAMS suggested that the l/b ratios should be determined by preliminary tests to ensure failure in the plates.

MR AUNE and MR BRYNILDSEN agreed since they required a shear value for the plate.

PROF MOHLER said that the purpose of the test was to test the joint and not just the plate.

HERR FRECH said that the load capacity of the nails and the plate were required. Square plates, he continued, would produce shearing of the nails while narrow plates could produce shear in the plates.

It was agreed that this paper should appear as an annexe to the RILEM Standard on Joints.

6 PLYWOOD

DR BOOTH, introducing papers 7-4-1 and 7-4-2 "The Determination of the Mech Properties of Plywood containing Defects" and "Comments received on 7-4-1" explained that this second draft on testing plywood was the result of a united effort by himself,

Dr Kuipers, Dr Noren and Dr Wilson. He thought that the only problems that remained unresolved concerned the rate of loading, specimen size, large deflections with thinner specimens and shear.

DR WILSON introduced "The Effect of Rate of Testing Speed on the Ultimate Tensile Stress of Plywood" (CIB-W18/7-4-3). He explained that both the in-grade and clear plywood specimens higher mean and the five per cent exclusion values were achieved using the 0.003 in/in/min rate of strain rather than the 0.001 in/in/min rate. The choice for rate of loading, he continued, was between a constant rate of strain and a constant time to failure. He preferred constant time to failure. At the 0.001 in/in/min rate of strain average testing time was 4.5 min, at 0.003 in/in/min the time fell to 1.5 min.

PROF LARSEN agreed with Dr Wilson that time to failure should be specified since this would be consistent with the testing of joints.

MR CURRY said that it was not practical to specify a constant rate of strain for joints but it was for solid timber, he favoured a constant rate of cross-head motion.

MR SUNLEY pointed out that time to failure could be open to abuse with loads perhaps applied slowly at first and then more rapidly to achieve failure within the time limit.

PROF MOHLER asked why the test methods proposed by Dr Booth were different to the agreed ISO standards on tension, bending and compression. The ISO standards specified time to failure, he said.

DR BOOTH explained that the ISO standards were for testing defect-free specimens and paper 7-4-1 was concerned with in-grade plywood. The ISO standard required a constant rate of loading with failure within a given time.

DR NOREN said, and it was generally agreed, that a constant rate of loading was impossible, particularly in compression.

DR KUIPERS proposed that an elapsed time of 5 ± 2 mins should be specified together with guidelines on typical rates of cross-head motion to achieve this time. This was accepted.

DR WILSON introduced "Comparison of the Effect of Specimen Size on the Flexural Properties of Plywood using the Pure Moment Test". (CIB-W18/7-4-4). He said that although COFI preferred the full size panel test they recognised the need for test procedures that could be carried out on standard test machines. He suggested that a choice of 300, 450 and 900 mm specimens could be given with correction factors for the size effects.

PROF NISKANEN produced test results to support his case for a 50 mm specimen. He agreed that 300 mm might be the most suitable for spruce plywood but he preferred 50 mm for combi and birch plywoods.

DR BOOTH pointed out that both Dr Wilson and Prof Niskanen's figures had shown a tendency for larger specimens to achieve higher stresses. He favoured the 300 mm specimen for the standard as a compromise between 50 mm and 1200 mm, with conversion factors, if necessary, for these other sizes. Dr Booth offered to draft a foreword that would include provision for these factors and for the testing of larger size specimens.

PROF MOHLER asked if these standard test procedures would be suitable for quality control.

DR BOOTH said that it was envisaged that this standard would only be used for deriving characteristic stresses. In answer to a question from PROF NISKANEN he agreed that the 50 mm specimen was probably more suitable for quality control.

MR SUNLEY assured Prof Niskanen that there would be no question of the United Kingdom asking Finland to carry out large scale tests on 300 mm specimens. He was sure that the extensive work carried out by Finland would retain its value.

DR WILSON asked for positive wording in the body of the standard to permit both 300 and 900 mm specimens. He pointed out that using a 900 mm specimen would reduce the number of tests to be carried out.

MR CURRY favoured only one standard size which would make the definition of characteristic stresses easier.

PROF LARSEN said that there were only two machines in the world capable of testing the 900 mm specimens. It would be absurd to alter the standard to suit them.

DR WILSON said that acceptance of a standard size depended partly on the cutting schedules. Was it possible for the parallel and perpendicular to the grain specimens to be cut from one sheet?

DR BOOTH said that the cutting schedule was included in this document concerned with testing rather than in a sampling document because it was intended to produce a random distribution of defects.

PROF LARSEN suggested that the cutting schedule should appear in an appendix rather than in the main body of the standard.

DR BOOTH asked the meeting for views on the length of the bending specimen. He pointed out that if the length was fixed for all thicknesses of plywood then deflections in some cases could be very large and he drew attention to MR SAARELAINEN'S comments in paper 7-4-2. If on the other hand the specimen length were related to thickness then tests would often be conducted on clear plies.

PROF LARSEN explained that the secondary loading effects noticed by Mr Saarelainen could be overcome by careful attention to details of the supports and loading heads on the test machine.

DR WILSON favoured a fixed specimen length with a constant bending moment span of 450 mm.

DR NOREN proposed that the length of specimen should be related to thickness but there should be a minimum constant bending moment span of 300 mm.

MR SUNLEY agreed with PROF LARSEN that the problems with test machines could be resolved and in any case bending was unlikely to be an important structural property for the thinner plywoods.

DR BOOTH introduced the problem of shear. He explained that from the rolling shear test, common in the UK, only results that were genuine shear failures were accepted. The ASTM two-rail method accepted all results regardless of the mode of failure, and called this shear in the plane of the plies. The choice was either to accept both methods of test or to dispense with one of them. If the ASTM method was to be used, continued Dr Booth, he thought that only genuine shear failure results should be used to determine characteristic stress.

MR BROWN favoured the ASTM method. He did not consider that manufacturing characteristics were fully represented in the rolling shear test.

DR WILSON and DR KUIPERS also spoke in favour of the ASTM method.

PROF MOHLER expressed doubts about the compression test. He thought that by building up the test specimen from several layers of plywood the effects of defects would be completely masked by clear plies.

DR BOOTH agreed but preferred this to the test method used by COFI where buckling was restrained.

It was agreed that paper CIB W18/7-4-1 should now be referred back to the sub-committee for consideration of the particular points that had been discussed.

DR NOREN agreed to produce a paper for the next meeting on sampling plywood and the evaluation of test results.

7 GLUED LAMINATED STRUCTURES

The chairman told the meeting that although it had been intended that glulam should be a major topic of discussion no papers had been received. However he reminded the delegates that the GLULAM sub-commission of FEMIB was now working on design and manufacturing codes and asked for opinions on how W18 should become involved with GLULAM.

PROF LARSEN said that he saw no reason for W18 to become involved in producing grading rules or manufacturing standards for glued laminated structures since these two topics had not been the concern of the commission for plywood.

MR SUNLEY pointed out that design could not be isolated from grading. Before producing standards for glulam it was essential that they ensure suitable grades existed.

DR NOREN said that W18 should discuss how to arrive at characteristic stress values for glulam and this would be more difficult than for solid timber.

DR KUIPERS asked what stress values GLULAM would be using for their designs.

MR CURRY said that since GLULAM was a manufacturing organisation he did not expect their stresses to be acceptable to W18.

PROF LARSEN said that W18 should not co-operate with GLULAM.

DR KUIPERS believed that W18 should be prepared to co-operate with anyone that had constructive ideas to offer, and this included GLULAM.

MR SUNLEY agreed with Dr Kuipers and asked Dr Armbruster if it would be possible for W18 to see the GLULAM design code.

DR ARMBRUSTER said that he would try to produce the code for the next meeting of W18.

DR BANY told the meeting that Poland had recently introduced a new timber design code. He hoped to have an English translation of this code available for the next meeting of W18.

8 LOAD DURATION

PROF LARSEN introduced "Code Rules Concerning Strength and Loading Time" (CIB-W18/7-9-1). He explained that the paper assumed an approximation to the Madison strength/time

relation and all loads were adjusted to the shortest load duration.

After a short discussion it was agreed that this paper should be included in the Timber Code.

MR BRYNILDSEN reported to the Commission on progress in the joint CIB-W18/IUFRO Working Party on Time and Moisture Effects (CIB-W18/7-106-1). He explained that the purpose of the sub-group was to study the work on moisture content and long-term stresses carried out by Prof Madsen, University of British Columbia, and to relate it to European species. Two pilot projects investigating matching techniques were progressing in Sweden and the United Kingdom. If these projects were successful the amount of testing required would be greatly reduced. Mr Brynildsen also told the meeting that it might be necessary to ship material to Vancouver for testing by Prof Madsen since it would be difficult to find adequate facilities in Europe.

9 LONG-TERM JOINT TESTS

DR KUIPERS introduced "Long Duration Tests on Timber Joints" (CIB-W18/7-7-2). He explained that this was an interim report which was not complete in all details. He drew attention to Fig 8, 9, 10 which compared his test results against the 'Madison curve'. Fig 9, said Dr Kuipers, showed that toothed-plate connectors were less influenced by time than the other joints tested.

PROF LARSEN suggested that for nailed joints the square root of the Madison curve should be considered since the joint was dependent on the yield strength of the steel nails. He pointed out that such an adjustment would put the results shown in Fig 10 nearer to their expected values.

10 TIMBER CODE

PROF LARSEN introducing "CIB Timber Code: Chapter 5.3 Mechanical Fasteners" (CIB-W18/7-100-1), drew attention to the inclusion of formula 5.3.1.1a for the calculation of the characteristic load-carrying capacity of nails. He explained that acceptance of this expression would reduce the need for testing and since 'k' would vary with species it should be applicable to both hardwoods and softwoods. For simplicity, loading parallel and perpendicular to the grain had been taken as equal to each other.

DR BOOTH asked how the factors given on page 3 had been derived for board to timber joints.

PROF LARSEN said that much of this code was based on other national codes and engineering judgment. The background work, if any, was not always available.

After a short discussion Prof Larsen agreed that he would redraft this paper for the next meeting and would take into account any written comments he received.

11 FIBRE BUILDING BOARDS

MR BRYNILDSEN introduced "Fibre Building Boards for CIB Timber Code" (CIB-W18/7-13-1) and said that the figures given on page 3 for rolling shear should be factored by 0.5. He drew attention to the factors for long-term loading, page 4, and said that these were applicable to all boards with no distinction between oil-tempered and ordinary fibre boards.

Both PROF LARSEN and MR CURRY said that this paper would not be acceptable to the whole of Europe and pointed out that it should follow the pattern set by plywood;

with testing, sampling and evaluation of results as separate topics.

DR KUIPERS thought that table 4 should be included although in reality the values would probably vary between manufacturers.

DR BOOTH considered it the manufacturers' responsibility to produce details of long-term strength and other properties. He would also have preferred the permanent load factor equal to unity with the other factors related to it.

It was agreed that although this paper provided a useful introduction of fibre building boards to the Commission further discussion would be needed before it was included in the Code.

12 BRACING OF STRUTS

MR SIMON introduced "Lateral Bracing of Timber Struts" (CIB-W18/7-2-1), explaining that the paper was primarily concerned with the failures that had occurred in pre-fabricated trusses in South Africa. Analytical methods had not been satisfactory and rule-of-thumb recommendations based on experience had been substituted. Mr Simon described the experimental work that had been undertaken and how the modes of failure that had been achieved had not been as predicted.

MR BRYNILDSEN said that failures of this type were not a problem in the Nordic countries since sheeting under the tiles provided adequate bracing.

PROF MOHLER and MR SUNLEY expressed interest in the paper saying that there had been failures in Germany and the United Kingdom attributable to inadequate bracing.

At this stage in the meeting Mr Sunley vacated the Chair and by common consent Dr Booth acted as chairman for the remainder of the meeting.

13 JOINTED BEAMS

PROF MOHLER introduced his paper "Tests with Mechanically Jointed Beams with a Varying Spacing of Fasteners" (CIB-W18/7-7-3). He explained that the paper was in support of an amendment to CIB Timber Standard O2 (paper CIB-W18/6-11-1) and proposed that the spacing of fasteners should be defined as $s = 0.75 s_{\min} + 0.25 s_{\max}$.

It was agreed that Standard O2 should be amended.

14 TORSIONAL TESTING OF SOLID AND LAMINATED TIMBER

PROF MOHLER gave a short talk, illustrated by photographic slides, on his paper "Strength and Long-term Behaviour of Lumber and Glued Laminated Timber under Torsion Loads" (CIB-W18/7-6-1). During the discussion that followed Prof Mohler said that many more tests would have to be carried out before the results could be included in either the German or CIB Codes.

15 SWEDISH TIMBER HOUSING

DR NOREN spoke to the delegates on work being carried out at the Swedish Forest Products Research Laboratory by MR B ERIKSSON on timber housing. Although there was nothing new or revolutionary in the system it included many interesting features that made it suitable for all sizes of builders and for varying degrees of automation said Dr Noren. Using slides to illustrate his talk Dr Noren showed how this building

system placed great emphasis on insulation, and on an unbroken vapour barrier between the inner and outer walls of the structure.

DR BOOTH closed the meeting and thanked DR NOREN and MR SCHMIDT, as representatives of the Swedish Forest Products Research Laboratory, for their hospitality and for their invaluable assistance in arranging and running the meeting.

After the meeting the delegates were escorted on a tour of building sites in the suburbs of Stockholm by Tr&Information AB (Swedish Timber Council).

16 NEXT MEETING

MR MONTFORT of Institute National du Logement has kindly undertaken to arrange the next meeting of CIB-W18 for 19, 20, 21 October 1977 in Brussels. Topics for discussion will include:

- 1 Sampling of plywood and evaluation of test results
- 2 Glulam design
- 3 Timber fasteners
- 4 Fibre building boards
- 5 The Polish timber design code

17 PAPERS PRESENTED AT THE MEETING

- ✓ CIB-W18/7-2-1 Lateral Bracing of Timber Struts - J A Simon
- ✓ CIB-W18/7-4-1 Methods of Test for the Determination of Mechanical Properties of Plywood - L G Booth, J Kuipers, B Noren, C R Wilson
- ✓ CIB-W18/7-4-2 Comments received following circulation of CIB-W18/7-4-1
- ✓ CIB-W18/7-4-3 The Effect of Rate of Testing Speed on the Ultimate Tensile Stress of Plywood - C R Wilson, A V Parasin
- ✓ CIB-W18/7-4-4 Comparison of the Effect of Specimen Size on the Flexural Properties of Plywood using the Pure Moment Test - C R Wilson, A V Parasin
- CIB-W18/7-6-1 Strength and Long-term Behaviour of Lumber and Glued-Laminated Timber under Torsion Loads - K Möhler
- ✓ CIB-W18/7-7-1 Testing of Integral Nail Plates as Timber Joints - K Möhler
- ✓ CIB-W18/7-7-2 Long Duration Tests on Timber Joints - J Kuipers
- ✓ CIB-W18/7-7-3 Tests with Mechanically Jointed Beams with a Varying Spacing of Fasteners - K Möhler
- ✓ CIB-W18/7-9-1 Code Rules Concerning Strength and Loading Time - H J Larsen, E Theilgaard
- ✓ CIB-W18/7-13-1 Fibre Building Boards for CIB Timber Code - O Brynildsen
- ✓ CIB-W18/7-100-1 CIB Timber Code; Chapter 5.3 Mechanical Fasteners CIB Timber Standard 06 and 07 - H J Larsen
- ✓ CIB-W18/7-106-1 Meeting of CIB-W18/IUFRO Working Party on Time and Moisture Effects

✓ 7-103-1 ISO Technical Committees and Membership of ISO/TC 165

✓ CIB-W18/7-104-1 Volume 1: Common Unified Rules for Different Types of Construction and Material

18 CURRENT LIST OF CIB-W18 TECHNICAL PAPERS

Technical papers presented to Working Commission W18 - Timber Structures are classified by a code identifying the meeting at which the paper was presented, the subject heading and the number of the paper. The full classification number of a document will start with CIB-W18, although where the context is clear this prefix may be omitted.

Example: CIB-W18/4-102-5

refers to paper 5 (Extract from Norwegian Standard NS 340 - "Timber Structures") on subject 102 (Structural Design Codes) presented at the fourth meeting of W18 (Paris, February 1975).

Published documents emanating from the Commission will simply be numbered in the order in which they appear.

Meetings are classified in chronological order:

- 1 Princes Risborough, England; March 1973
- 2 Copenhagen, Denmark; October 1973
- 3 Delft, Netherlands; June 1974
- 4 Paris, France; February 1975
- 5 Karlsruhe, Federal Republic of Germany; October 1975
- 6 Aalborg, Denmark; June 1976
- 7 Stockholm, Sweden, Feb/March 1977

Subjects are denoted by the following numerical classification:

- 1 Limit State Design
- 2 Timber Columns
- 3 Symbols
- 4 Plywood
- 5 Stress Grading
- 6 Stresses for Solid Timber
- 7 Timber Joints and Fasteners
- 8 Load Sharing
- 9 Duration of Load
- 10 Timber Beams
- 11 Environmental Conditions
- 12 Laminated Members

- 13 Particle and Fibre Building Boards
- 14 Trussed Rafters
- 100 CIB Timber Code
- 101 Loading Codes
- 102 Structural Design Codes
- 103 International Standards Organisation
- 104 Joint Committee on Structural Safety
- 105 CIB Programme, Policy and Meetings
- 106 International Union of Forestry Research Organisations

Listed below, by subjects, are all papers that have to date been presented to W18. When appropriate some papers are listed under more than one subject heading.

LIMIT STATE DESIGN

- 1-1-1 Paper 5 Limit State Design - H J Larsen
- 1-1-2 Paper 6 The use of partial safety factors in the new Norwegian design code for timber structures - O Brynildsen
- 1-1-3 Paper 7 Swedish code revision concerning timber structures - B Norén
- 1-1-4 Paper 8 Working stresses report to British Standards Institution Committee BLC/17/2
- 6-1-1 On the application of the uncertainty theoretical methods for the definition of the fundamental concepts of structural safety - K Skov and O Ditlevsen

TIMBER COLUMNS

- 2-2-1 Paper 3 The Design of Solid Timber Columns - H J Larsen
- 3-2-1 Paper 6 Design of Built-up Timber Columns - H J Larsen
- 4-2-1 Paper 3 Tests with Centrally Loaded Timber Columns - H J Larsen and Svend Sondergaard Pedersen
- 4-2-2 Paper 4 Lateral-Torsional Buckling of Eccentrically Loaded Timber Columns - B Johansson
- 5-9-1 Strength of a Wood Column in Combined Compression and Bending with respect to Creep - B Kälsner and B Norén
- 5-100-1 Design of Solid Timber Columns - H J Larsen
- 6-100-1 Comments on Document 5-100-1, Design of Timber Columns - H J Larsen
- 6-2-1 Lattice Columns - H J Larsen
- 6-2-2 A Mathematical Basis for Design Aids for Timber Columns - H J Burgess
- 6-2-3 Comparison of Larsen and Perry Formulas for Solid Timber Columns - H J Larsen
- 7-2-1 Lateral Bracing of Timber Struts - J A Simon

SYMBOLS

- 3-3-1 Paper 5 Symbols for Structural Timber Design - J Kuipers and B Norén
- 4-3-1 Paper 2 Symbols for Timber Structure Design - J Kuipers and B Norén
- 1 Symbols for Use in Structural Timber Design

PLYWOOD

- 2-4-1 Paper 1 The Presentation of Structural Design Data for Plywood - L G Booth
- 3-4-1 Paper 3 Standard Methods of Testing for the Determination of Mechanical Properties of Plywood - J Kuipers
- 3-4-2 Paper 4 Bending Strength and Stiffness of Multiple Species Plywood - C K A Stieda
- 4-4-4 Paper 5 Standard Methods of Testing for the Determination of Mechanical Properties of Plywood - Council of Forest Industries, BC
- 5-4-1 The Determination of Design Stresses for plywood in the revision of CP 112 - L G Booth
- 5-4-2 Veneer Plywood for Construction - Quality Specification - ISO/TC 139 - Plywood, Working Group 6
- 6-4-1 The Determination of the Mechanical Properties of Plywood Containing Defects - L G Booth
- 6-4-2 In-grade versus Small Clear Testing of Plywood - C R Wilson
- 6-4-3 Buckling Strength of Plywood: Results of Tests and Recommendations for Calculations - J Kuipers and H Ploos van Amstel
- 7-4-1 Methods of Test for the Determination of the Mechanical Properties of Plywood - L G Booth, J Kuipers, B Norén, C R Wilson
- 7-4-2 Comments on Paper 7-4-1
- 7-4-3 The Effect of Rate of Testing Speed on the Ultimate Tensile Stress of Plywood - C R Wilson and A V Parasin
- 7-4-4 Comparison of the Effect of Specimen Size on the Flexural Properties of Plywood using the Pure Moment Test - C R Wilson and A V Parasin

STRESS GRADING

- 1-5-1 Paper 10 Quality specifications for sawn timber and precision timber - Norwegian Standard NS 3080
- 1-5-2 Paper 11 Specification for timber grades for structural use - British Standards BS 4978
- 4-5-1 Paper 10 Draft Proposal for an International Standard for Stress Grading Coniferous Sawn Softwood - ECE Timber Committee.

STRESSES FOR SOLID TIMBER

- 4-6-1 Paper 11 Derivation of Grade Stresses for Timber in UK - W T Curry
- 5-6-1 Standard Methods of Test for Determining some Physical and Mechanical Properties of Timber in Structural Sizes - W T Curry
- 5-6-2 The Description of Timber Strength Data - J R Tory
- 5-6-3 Stresses for EC1 and EC2 Stress Grades - J R Tory
- 6-6-1 Standard Methods of Test for the Determination of some Physical and Mechanical Properties of Timber in Structural Sizes (third draft) - W T Curry
- 7-6-1 Strength and Long-term Behaviour of Lumber and Glued-laminated Timber under Torsion Loads - K Möhler

TIMBER JOINTS AND FASTENERS

- 1-7-1 Paper 12 Mechanical fasteners and fastenings in timber structures - E G Stern
- 4-7-1 Paper 8 Proposal for a Basic Test Method for the Evaluation of Structural Timber Joints with Mechanical Fasteners and Connectors - RILEM, 3TT Committee
- 4-7-2 Paper 9 Test Methods for Wood Fasteners - K Möhler
- 5-7-1 Influence of Loading Procedure on Strength and Slip Behaviour in Testing Timber Joints - K Möhler
- 5-7-2 Recommendations for Testing Methods for Joints with Mechanical Fasteners and Connectors in Load-Bearing Timber Structures - RILEM 3TT Committee
- 5-7-3 CIB Recommendations for the Evaluation of Results of Tests on Joints with Mechanical Fasteners and Connectors used in Load-Bearing Timber Structures - J Kuipers
- 6-7-1 Recommendations for Testing Methods for Joints with Mechanical Fasteners and Connectors in Load-Bearing Timber Structures (seventh draft) - RILEM, 3TT Committee
- 6-7-2 Proposals for Testing Joints with Integral Nail Plates - K Möhler
- 6-7-3 Rules for Evaluation of Values of Strength and Deformation from Test Results - Mechanical Timber Joints - M Johansen, J Kuipers, B Norén
- 6-7-4 Comments to Rules for Testing Timber Joints and Derivation of Characteristic Values for Rigidity and Strength - B Norén
- 7-7-1 Testing of Integral Nail Plates as Timber Joints - K Möhler
- 7-7-2 Long Duration Tests on Timber Joints - J Kuipers
- 7-7-3 Tests with Mechanically Jointed Beams with a Varying Spacing of Fasteners - K Möhler
- 7-100-1 CIB Timber Code Chapter 5.3 Mechanical Fasteners; CIB Timber Standard 06 and 07 - H J Larsen

LOAD SHARING

- 3-8-1 Paper 8 Load Sharing - An Investigation on the State of Research and Development of Design Criteria - E Levin
- 4-8-1 Paper 12 A Review of Load Sharing in Theory and Practice - E Levin
- 4-8-2 Paper 13 Load Sharing - B Norén

DURATION OF LOAD

- 3-9-1 Paper 7 Definitions of Long Term Loading for the Code of Practice - B Norén
- 4-9-1 Paper 14 Long Term Loading of Trussed Rafters with Different Connection Systems - T Feldborg and M Johansen
- 5-9-1 Strength of a Wood Column in Combined Compression and Bending with Respect to Creep - B Källsner and B Norén
- 6-9-1 Long Term Loading for the Code of Practice (Part 2) - B Norén
- 6-9-2 Long Term Loading - K Möhler
- 6-9-3 Deflection of Trussed Rafters under Alternating Loading during a Year - T Feldborg and M Johansen
- 7-6-1 Strength and Long Term Behaviour of Lumber and Glued-Laminated Timber under Torsion Loads - K Möhler
- 7-9-1 Code Rules Concerning Strength and Loading Time - H J Larsen and E Theilgaard

TIMBER BEAMS

- 4-10-1 Paper 6 The Design of Simple Beams - H J Burgess
- 4-10-2 Paper 7 Calculation of Timber Beams Subjected to Bending and Normal Force - H J Larsen
- 5-10-1 The Design of Timber Beams - H J Larsen

ENVIRONMENTAL CONDITIONS

- 5-11-1 Climate Grading for the Code of Practice - B Norén
- 6-11-1 Climate Grading for the Code of Practice - B Norén

LAMINATED MEMBERS

- 6-12-1 Manufacture of Glued Timber Structures - J Kuipers

FIBRE BUILDING BOARDS

- 7-13-1 Fibre Building Boards for CIB Timber Code - O Brynildsen

TRUSSED RAFTERS

- 4-9-1 Paper 14 Long Term Loading of Trussed Rafters with Different Connection Systems - T Feldborg and M Johansen
- 6-9-3 Deflection of Trussed Rafters under Alternating Loading During a Year - T Feldborg and M Johansen
- 7-2-1 Lateral Bracing of Timber Struts - J A Simon

CIB TIMBER CODE

- 2-100-1 Paper 2 A Framework for the Production of an International Code of Practice for the Structural Use of Timber - W T Curry
- 5-100-1 Design of Solid Timber Columns - H J Larsen
- 5-100-2 A Draft Outline of a Code of Practice for Timber Structures - L G Booth
- 6-100-1 Comments on Document 5-100-1; Design of Timber Columns - H J Larsen
- 6-100-2 A CIB Timber Code - H J Larsen
- 7-100-1 CIB Timber Code Chapter 5.3 Mechanical Fasteners; CIB Timber Standard 06 and 07 - H J Larsen

LOADING CODES

- 4-101-1 Paper 19 Loading Regulations - Nordic Committee for Building Regulations
- 4-101-2 Paper 20 Comments on the Loading Regulations - Nordic Committee for Building Regulations

STRUCTURAL DESIGN CODES

- 1-102-1 Paper 2 Survey of status of building codes, specifications etc, in USA - E G Stern
- 1-102-2 Paper 3 Australian codes for use of timber in structures - R H Leicester
- 1-102-3 Paper 4 Contemporary Concepts for Structural Timber Codes - R H Leicester
- 1-102-4 Paper 9 Revision of CP 112 - First draft, July 1972 - British Standards Institution
- 4-102-1 Paper 15 Comparison of Codes and Safety Requirements for Timber Structures in EEC Countries - Timber Research and Development Association
- 4-102-2 Paper 16 Nordic Proposals for Safety Code for Structures and Loading Code for Design of Structures - O A Brynildsen
- 4-102-3 Paper 17 Proposals for Safety Codes for Load-Carrying Structures - Nordic Committee for Building Regulations
- 4-102-4 Paper 18 Comments to Proposal for Safety Codes for Load-Carrying Structures - Nordic Committee for Building Regulations
- 4-102-5 Paper 21 Extract from Norwegian Standard NS 3470 "Timber Structures"

4-102-6 Paper 22 Draft for Revision of CP 112 "The Structural Use of Timber" -
W T Curry

INTERNATIONAL STANDARDS ORGANISATION

- 3-103-1 Paper 2 Method for Preparation of Standards Concerning the Safety of
Structures - Published by International Standards Organisation
(ISO/DIS 3250).
- 4-103-1 Paper 1 A Proposal for Undertaking the Preparation of an International
Standard on Timber Structures - International Standards Organisation
- 5-103-1 Comments on the Report of the Consultation with Member Bodies concerning
ISO/TS/P129 - Timber Structures - Dansk Ingeniorforening
- 7-103-1 ISO Technical Committees and Membership of ISO/TC 165

JOINT COMMITTEE ON STRUCTURAL SAFETY

- 3-104-1 Paper 1 International System of Unified Standard Codes of Practice for
Structures - Published by Comité Européen du Béton (CEB)
- 7-104-1 Volume One: Common Unified Rules for Different Types of Construction
Material - CEB

CIB PROGRAMME, POLICY AND MEETINGS

- 1-105-1 Paper 1 A note on international organisations active in the field of
utilisation of timber - P Sonnemans
- 5-105-1 The Work and Objectives of CIB-W18 - Timber Structures - J G Sunley

INTERNATIONAL UNION OF FORESTRY RESEARCH ORGANISATIONS

- 7-106-1 Time and Moisture Effects - CIB W18/IUFRO S5.02-03 Working Party

INTERNATIONAL COUNCIL FOR BUILDING RESEARCH STUDIES AND DOCUMENTATION

WORKING COMMISSION W18 - TIMBER STRUCTURES

ISO TECHNICAL COMMITTEES

and

MEMBERSHIP OF ISO/TC 165

Stockholm, Sweden

February/March 1977

Inventory of ISO/TCs with which TC 165 should liaise
(Extract from ISO Memento 1976)

a) TCs concerned with timber products and related materials

REF	TITLE AND SCOPE	SECRETARIAT
TC 55	Sawn timber and sawlogs	GOST
	Standardization of sawlogs, non-profiled sawn timber and test methods of mechanical properties of wood.	
SC 1	Test methods of physical and mechanical properties of wood	GOST
SC 2	Coniferous sawn timber	GOST
SC 3	Broadleaved sawn timber	GOST
SC 4	Coniferous sawlogs	GOST
SC 5	Broadleaved sawlogs	AFNOR
TC 89	Fibre building boards	DIN
	Standardization of fibre building boards and other similar board products made from wood or other lignocellulosic fibrous materials, including nomenclatures, specifications and test methods.	
WG 1	Co-ordination and editing	DIN
WG 2	Sampling, cutting of test pieces and inspection	DIN
WG 4	Dimensional stability	DIN
WG 5	Determination of punctural resistance	CSN
WG 6	Dimensions and tolerances	SIS
WG 7	Quality specifications	DIN
WG 8	Technological properties	SIS
WG 9	Internal bond test	AFNOR
WG 10	Soft boards. Special quality requirements	DIN
WG 11	Special quality requirements and terminology	SIS
TC 139	Plywood	DIN
<i>Chairman:</i> <i>Dr. D. Noack</i> <i>Germany</i> <i>(1977)</i>	Standardization of plywood panels, including terminology, classifications, test methods, dimensions and tolerances, and specifications.	
WG 1	Dimensions and tolerances	AFNOR
WG 2	Grading	CSN
WG 4	Sampling, cutting and inspection	DIN
WG 5	Test methods	DIN
WG 6	Specifications for structural plywood	SCC*
WG 7	Core plywood	BSI
TC 151	Particle boards	DIN
<i>Chairman:</i> <i>Dr. D. Noack</i> <i>Germany</i> <i>(1977)</i>	Standardization of particle boards and other similar board products made from wood or other lignocellulosic fibrous materials, including terminology, classifications, test methods, dimensions and tolerances, and specifications.	

Note. — The figures in brackets show the year at the end of which the term of office expires.

* Provisional

b) TCs concerned with general matters

REF.	TITLE AND SCOPE	SECRETARIAT
TC 59	Building construction	AFNOR
<i>Chairman:</i> <i>Mr. G. Blachère</i> <i>France</i> <i>(1976)</i>	Standardization of: <ol style="list-style-type: none"> 1. Terminology in the construction and civil engineering industry. 2. General geometric requirements for buildings, building elements, components and products, including modular co-ordination and its basic principles, joints, tolerances and fits. 3. Other general performance requirements for buildings and building elements (user needs) including the co-ordination of these with performance requirements of building components and products to be used in the construction and civil engineering industry. are excluded: <ul style="list-style-type: none"> - Bases for design of structures (TC 98) - Particular geometric requirements and performance requirements of building components and products which are in the scope of separate ISO technical committees. 	
SC 1	Dimensional and modular co-ordination	SIS
SC 2	Terminology, symbols and unification of language	AFNOR
WG 1	Terminology	NSF
SC 3	Functional/user requirements and performance in building construction	BSI
SC 4	Limits and fits in building construction	DS
WG 1	Tolerances in building. General principles	BSI
WG 2	Measurement procedures in building	SIS
WG 3	Classes of tolerances for the building industry	DIN
SC 5	Joints	AFNOR
SC 6	Structures, external envelopes, internal subdivisions	AFNOR*
WG 1	Pre-fabricated components for floors and roofs, structural framing components and vertical loadbearing components	GOST
WG 3	Curtain walling and panels and vertical non-loadbearing components	AFNOR
WG 4	Staircases and staircase wells	SIS
WG 6	Windows	BSI
WG 7	Pitched (sloping) and flat roof coverings, non structural	AFNOR
WG 8	Floor and wall finishes	AFNOR
WG 9	Ceiling components	AFNOR
SC 7	Equipment, services and drainage	AFNOR
WG 2	Bathrooms and toilets	AFNOR
WG 3	Mechanical transporting systems	AFNOR
WG 4	Accommodation ducts	BSI
SC 8	Jointing products	AFNOR*
SC 9	Building hardware	AFNOR
SC 10	Doorsets	AFNOR*
SC 11	Kitchen equipment	SIS
TC 98	Bases for design of structures	PKNiM
	Standardization of the bases for design of structures irrespective of the material of construction including especially terminology and symbols, loads, forces and other actions and limitations of deformations. Consideration and coordination of basic safety requirements concerning the structures as a whole, including considerations of structures made of particular materials (steel, stone, concrete, wood, etc.) as far as is necessary for the preparation of common systems of safety, and in liaison with the relevant technical committees.	
WG 1	Earthquake forces	JISC
WG 2	Rules for the use of the international system of units for the design of structures	PKNiM
SC 1	Terminology and symbols	AFNOR
WG 1	Terms, definitions and symbols	AFNOR
WG 2	Notations for line printers	—
SC 2	Safety of structures	PKNiM
SC 3	Loads, forces and other actions	GOST
WG 1	Snow loads	NSF
WG 2	Wind loads	DIN
SC 4	Limitation of deformations	BSI

b) 0-members of ISO/TC 165 Timber Structures as per 1977-01-31

AUSTRIA/AUTRICHE (ON)

Österreichisches Normungsinstitut
Leopoldsgasse 4
Postfach 130
A-1021 Wien 2

CHILE/CHILI (INN)

Instituto Nacional de
Normalizacion
Matias Cousino 64-6^o piso
Casilla 995-Correo 1
Santiago

CUBA (NC)

Instituto Cubano de Normalización,
Metrologia y Control de la Calidad
Reina 408
La Habana

ETHIOPIA/ÉTHIOPIE (ESI)

Ethiopian Standards Institution
P.O. Box 2310
Addis Ababa

FINLAND/FINLANDE (SFS)

Suomen Standardisoimiliitto r.y.
P.O. Box 205
SF-00121 Helsinki 12

IRAN (ISIRI)

Institute of Standards and Industrial
Research of Iran
Ministry of Industries and Mines
P.O. Box 2937
Teheran

IRAQ/IRAK (IOS)

Iraqi Organization for Standards
Planning Board
P.O. Box 11185
Baghdad

IRELAND/IRLANDE (IIRS)

Institute for Industrial Research
and Standards
Ballymun Road
Dublin-9

ISRAEL/ISRAËL (SII)

Standards Institution of Israel
42 University Street
Tel Aviv 69977

JAPAN/JAPON (JISC)

Japanese Industrial Standards
Committee
Ministry of International Trade
and Industri
3-1, Kasumigaseki, Chiyodaku
Tokyo

PAKISTAN (PSI)

Pakistan Standards Institution
39 Garden Road, Saddar
Karachi-3

PORTUGAL (IGPAI)

Repartição de Normalização
Avenida de Berna 1
Lisboa-1

SINGAPORE/SINGAPOUR (SISIR)

Singapore Institute of Standards
and Industrial Research
179, River Valley Road
P.O. Box 2611
Singapore 6

SUDAN/SOUDAN (SSD)

Standardization and Quality
Control Department
Ministry of Industry and Mining
P.O. Box 2184
Khartoum

SWEDEN/SUËDE (SIS)

Sveriges Standardiseringskommission
Box 3 295
S-103 66 Stockholm

TURKEY/TURQUIE (TSE)

Türk Standardlari Enstitüsü
Necatibey Caddesi 112
Bakanliklar
Ankara

USA (ANSI)

American National Standards
Institute
1430 Brodway
New York, N.Y. 10018

YOGOSLAVIA/YOUGOSLAVIE (JZS)

Jugoslovenski zavod za
standardizaciju
Slobodana Penezića- Krcuna
br. 35
Post. pregr. 933
11000 Beograd

List of P- and O-MEMBER COUNTRIES OF ISO/TC 165 (with addresses)a) P-members of ISO/TC 165 Timber Structures as per 1977-01-31

AUSTRALIA/AUSTRALIE (SAA)

Standards Association of Australia
Standards House
80-86 Arthur Street
North Sydney-N.S.W.2060

BELGIUM/BELGIQUE (IBN)

Institut belge de normalisation
Av. de la Brabançonne 29
B-1040 Bruxelles

CANADA (SCC)

Standards Council of Canada
International Standardization
Branch
Meadowvale Corporate Centre
2000 Argentia Road,
Suite 2-401
Mississauga, Ontario
L5N 1P7

CZECHOSLOVAKIA/TCHÉCOSLOVAQUIE (CSN)

Úřad pro normalizaci a měření
Václavské náměstí 19
113 47 Praha 1

DENMARK/DANEMARK (DS)

(represented by DIF) (SECRETARIAT)

Dansk Ingeniørforening
Vester Farimagsgade 31
DK 1606 København V

FRANCE (AFNOR)

Association française de normalisation
Tour Europe
Cedex 7
92080 Paris - La Défense

GERMANY/ALLEMAGNE (DIN)

DIN Deutsches Institut für
Normung
Burggrafenstrasse 4-7
Postfach 1107
1 Berlin 30

INDIA/INDE (ISI)

Indian Standards Institution
Manak Bhavan
9 Bahadur Shah Zafar Marg
New Delhi 110001

NETHERLANDS/PAYS-BAS (NNI)

Nederlands Normalisatie-Instituut
Polakweg 5
Rijswijk

NEW ZEALAND/NOUVELLE-ZELANDE (SANZ)

Standards Association of New Zealand
Private Bag
Wellington

NORWAY/NORVÈGE* (NSF)

(represented by NBR)

Norges Byggstandardiseringsraad
Københavngatan 10
N-Oslo 5

ROMANIA/ROUMANIE (IRS)

Institutul Român de Standardizare
Casuta Postala 6214
Bucarest 1

SOUTH AFRICA, REP. of/AFRIQUE DU SUD,
Rép. d' (SABS)

South African Bureau of Standards
Private Bag X191
Pretoria
0001

UNITED KINGDOM/ROYAUM-UNI (BSI)

British Standards Institution
Park Street
London W1A 2BS

USSR/URSS (GOST)

Gosudarstvennyj
Komitet Standartov
Soveta Ministrov S.S.S.R.
Leninsky Prospekt 9b
Moskva 117049

P members - Participating

O members - Observing

INTERNATIONAL COUNCIL FOR BUILDING RESEARCH STUDIES AND DOCUMENTATION

WORKING COMMISSION W18 - TIMBER STRUCTURES

VOLUME 1: COMMON UNIFIED RULES FOR
DIFFERENT TYPES OF CONSTRUCTION AND MATERIAL

STOCKHOLM, SWEDEN - FEBRUARY/MARCH 1977

VOLUME I

COMMON UNIFIED RULES

FOR DIFFERENT TYPES OF CONSTRUCTION AND MATERIAL

Fourth DRAFT - November 1976

CONTENTS

- 1 DESIGN - OBJECTIVES AND GENERAL RECOMMENDATIONS
 - 1.1 Scope
 - 1.2 Aims of Design
 - 1.3 Design Requirements
 - 1.4 Classification according to consequences of failure
- 2 LIMIT STATES - DEFINITION AND CLASSIFICATION
 - 2.1 General
 - 2.2 Ultimate limit states
 - 2.3 Serviceability limit states
 - 2.4 Other considerations
- 3 LIMIT STATE DESIGN
 - 3.1 General
 - 3.2 Levels of limit state design
- 4 ACTIONS
 - 4.1 Definitions
 - 4.2 Qualitative classification of actions
 - 4.3 Actions and situations
- 5 PROPERTIES OF MATERIALS
- 6 GEOMETRICAL DATA
- 7 METHODS OF ANALYSIS
 - 7.1 General
 - 7.2 Analysis - Ultimate limit state
 - 7.3 Analysis - Serviceability limit state
 - 7.4 Model Analysis and Testing
 - 7.5 Experimental development of analytical procedures.
- 8 GENERAL CONDITIONS FOR USE OF MATERIALS AND COMPONENTS
 - 8.1 Standardised Area
 - 8.2 Materials and Components in non-standardised area
 - 8.3 Agrément
- 9 CONTROL AND ACCEPTANCE OF MATERIALS AND COMPONENTS
 - 9.1 General
 - 9.2 Initial Tests
 - 9.3 Production Control
 - 9.4 Quality Control
 - 9.5 Certification of conformity and origin
- 10 THE METHOD OF PARTIAL COEFFICIENTS (LEVEL I)
 - 10.1 General
 - 10.2 Representative values of the Actions
 - 10.3 Combinations of Actions
 - 10.4 Methods of Analysis
 - 10.5 Geometrical Data
 - 10.6 Verification Procedures
- 11 BASIC NOTATIONS
- 12 UNITS
- Appendix I - Level 2 Method
- Appendix II - Proposed methods for derivation of characteristic values for actions
- Appendix III - Variable Actions

1 DESIGN - OBJECTIVES AND GENERAL RECOMMENDATIONS

1.1 - SCOPE

Its primary purpose should be taken as the need to provide an agreed background for the various national committees and international bodies in formulating their own recommendations.

This document deals with a common basis for setting up codes for the design and construction of buildings and civil engineering structures to ensure an adequate and appropriate treatment of safety and serviceability whatever the material or type of construction.

1.2 - AIMS OF DESIGN

The phrase "acceptable probabilities" implies that due account is taken of the technical and economic conditions obtaining at any given time and in any individual country or group of countries. Also the aspect of relevant and useful lives for different categories of structure should be reflected in the probability level.

The aim of design is the achievement of acceptable probabilities that the structure being designed will not become unfit for the use for which it is required during some reference period and having regard to its intended life.

The phrase "degree of safety" implies level of structural reliability.

Thus, all structures or structural elements should be designed to sustain, with an appropriate degree of safety, all loads and deformations liable to occur during construction and proper use, to perform adequately in normal use and to have adequate durability during the life of the structure.

For the purpose of this document, it is assumed that:

- projects are carried out by qualified engineers;
- the required supervision is always available in factories and on site;
- the construction is carried out by personnel having both the required skill and experience.

To achieve this aim, the design method should be based on scientific theories, experimental data, and experience of past design practice, interpreted statistically as far as possible. Further, safety, serviceability and durability are not simply a function of design calculations; they also depend on the quality control exercised in fabrication and the supervision on

It is assumed that the actual conditions of use of the structure during its life do not depart significantly from those specified during the design stage.

It is not generally required that structures should be able to sustain certain accidental loads such as those arising in wars. However, in the case of certain loads or actions such as explosive pressures, vehicle impacts, etc., when their frequency or intensity is ill-defined or unforeseeable, the engineer, or other responsible authority, should ensure that, either in the details of the construction or in the concept of the structure, the risks associated with these effects are limited.

In general, it is not necessary to carry out detailed calculations for each limit state; simple deemed to satisfy requirements will suffice for some limit states.

site, the magnitude and control of unavoidable imperfections, and the qualifications and skill of all the personnel involved.

The maintenance of the conditions of use of the structure during its intended life is also implicitly assumed.

1.3 - DESIGN REQUIREMENTS

The criteria relating to the performance of the structure should be clearly defined; this is most conveniently treated in terms of limit states which, in turn, are related to the structure ceasing to fulfil the function, or to satisfy the conditions for which it was designed.

All relevant limit states should be considered in the design so as to ensure an adequate degree of safety and serviceability. The usual approach will be to design on the basis of the most critical limit state and then to check that the remaining limit states will not be reached.

1.4 - CLASSIFICATION ACCORDING TO CONSEQUENCES OF FAILURE

The consequences of failure may be considered from two viewpoints:

- (i) Risk to life or concern for public reaction (or aversion) to possible failures;
- (ii) Economic consequences due to:
 - (a) loss of use of structure and all ancillary costs;
 - (b) need for replacement or repair.

In the design process or, more accurately, in the codification of that process, the consequences of failure may be classified as:

- Not serious - risk to life negligible and economic consequences small;
- Serious - risk to life exists and economic consequences considerable;
- Very Serious - risk to life great and economic consequences very great.

2 LIMIT STATES - DEFINITION AND CLASSIFICATION

2.1 - GENERAL

A structure, or part of a structure, is considered unfit for use when it exceeds a particular state, called a limit state, beyond which it infringes one of the criteria governing its performance or use.

The limit states can be placed in two categories:

- (a) the ultimate limit states, which are those corresponding to the maximum load-carrying capacity;
- and (b) the serviceability limit states, which are related to the criteria governing normal use and durability.

2.2 - ULTIMATE LIMIT STATES

The ultimate limit state may be reached due to:

- (a) Loss of equilibrium of a part or the whole of the structure considered as a rigid body.
- (b) Rupture of critical sections of the structure or excessive deformation.
- (c) Transformation of the structure into a mechanism.
- (d) Buckling due to elastic or plastic instability.
- (e) Fatigue.

Although this limit state is primarily associated with the maximum load carrying capacity of the structure, it may, in effect, be reached due to gross deformation leading to a substantial change in geometry and, hence, the need to replace the structure. Such may be the case where the sensitivity of the structure to the effects of repetition of loads or to possible resonance under some critical loading is important.

For certain design processes and materials, it may be convenient to define the ultimate limit state by the attainment of the elastic limit at some point in the structure.

Fatigue may cause failure of a structural element, or a structure in certain cases, but the loads associated with this type of failure are essentially those obtaining under service conditions.

Fatigue is only relevant to special types of structure e.g. certain bridges, and its treatment requires the definition of a fatigue loading spectrum and consideration of the fatigue characteristics of the materials, individual structural elements and their connections.

The deformation of certain elements of a structure e.g. roof slabs or units, can cause an increase in loading e.g. due to ponding. In limiting the deformations this aspect should be borne in mind and account taken of it.

Examples of local damage are cracking, spalling, localised yielding or buckling, splitting, slip of bolted friction joint, etc., of parts of the structure or of infilling panels, partitions, etc.

This limit state arises only infrequently and, generally, it is the effects on the occupants or users of the structure which determine the appropriate limitations.

2.3 - SERVICEABILITY LIMIT STATES

(a) Deformation

The deformation of the structure, or any part of the structure, should not adversely affect the appearance or efficiency of the structure.

(b) Local Damage

Damage occurring in specific parts of the structure, which might entail excessive maintenance, or lead to corrosion, and hence adversely affect the appearance or efficiency of the structure, should be limited.

(c) Vibration

Where there is a likelihood of the structure being subjected to vibration from causes such as wind forces or machinery, measures should be taken to prevent discomfort or alarm, or impairment of its proper function.

(d) Other limit states

Where a structure is designed for some special or unusual function other criteria may be introduced to define appropriate limit states.

2.4 - OTHER CONSIDERATIONS

(a) Overall stability and robustness

The general arrangement of the structure and the connection of its various members or elements should be such as to give the structure an appropriate stability and robustness.

In particular, there should be a reasonable probability that the structure will not collapse catastrophically under the effect of misuse or accident. No structure can be expected to be resistant to the excessive loads or forces that could arise due to an extreme cause, but it should not be damaged to an extent disproportionate to the original cause.

In this respect, it is of importance to check that the structure has an adequate resistance to lateral forces. This resistance may result directly from the treatment of wind or seismic actions. However, in any event, the structure should have adequate resistance, at the ultimate limit state, to sustain a horizontal force equivalent to 1% of the mean value of the permanent actions (G). For most structures, appropriate "deemed to satisfy" clauses may be given in the appropriate Volume of the Model Code. This requirement may be achieved, in buildings, by:

(i) designing the structure in such a way that, at each storey in turn, any single load bearing member can become incapable of carrying any load without causing collapse of the structure or any significant part of it;

or (ii) where necessary, ensuring that any essential load carrying member cannot be made ineffective (by design or by protective measures).

Design according to (i) may be treated either by designing the remaining part of the structure such that it will carry a reduced design load or, by designing the remaining part of the structure according to some "deemed to satisfy" rules given in the appropriate volume of the Model Code.

For accidental situations, only a part of the total population of structures will be subject to an accidental action or be exposed to an accidental situation; however, a geographical region could be involved; the rarity of these actions and situations does not permit a statistical definition of the magnitude or probabilities of occurrence or any representative parameters; it is only possible, with respect to them, to assure a reduced probability of survival of the structure.

Thus, the concept of a conditional probability may be introduced when dealing with accidental situations.

Such accidental situations may arise in a structure:

- (a) immediately after the occurrence of a very unlikely action causing localised damage;
- or, (b) immediately after a very unlikely change in its environment, but changing in a significant manner the action effects in, or resistance of, the structure.

The required fire resistance period for the structure should be laid down by appropriate governmental bodies as a function of the use and size of the building.

The actual fire resistance will depend on the overall concept of the building, the actual loading, the interaction of the structural members and, for walls and floors, on the resistance to flame penetration and heat transference.

(b) Fire Resistance

Fire is a primary accidental hazard during which it is necessary to ensure the carrying capacity and integrity of the structure for a defined period of time in order to permit the evacuation of the occupants, to afford appropriate protection for fire fighting services, to prevent the spread of the fire and to protect adjoining property.

The verification of the fire resistance of a structure may be carried out by compliance with appropriate recommendations which are deemed to satisfy, by tests on comparable structures or elements, or by calculations based upon experimental data.

(c) Durability

The durability aspect of any structure is normally treated by attention to the detailed aspects of design, to the specification and control of materials and workmanship, with provision for protection and routine maintenance where necessary; different requirements should be stated to cover the range of environmental conditions met in practice.

3 LIMIT STATE DESIGN

3.1 - GENERAL

The seriousness of attaining a limit state in terms of loss of life, economic consequences and general danger to the community should be considered. This is a vital aspect since it is related to the general state of any particular nation's economy and development; hence government policy is involved and different categories of safety may be envisaged e.g. agricultural buildings to not require the same safety as multi-storey houses. Thus a judgement has to be made of the degree of safety relevant to each category of structure or structural part. In this respect, a classification according to different levels of structural reliability may be appropriate (see 1.4).

In general, the structural analysis will be in two stages, one dealing with the analysis of the structure as a whole to assess the action effects and the other dealing with the analysis of the individual sections of the structural elements under the assessed action effects.

The uncertainties require to be quantified by probability statements, these being made either on the basis of available statistical data or, where such data are inadequate, by past experience and judgement.

Limit state design is the procedure that has been evolved to enable the "Aims of Design" to be accomplished in a logical manner. Since the consequences of attaining a given limit state (and particularly the ultimate limit state) may vary considerably, different safety margins should be accepted for the different safety classes adopted (see 1.4).

In the design process, a calculation model should be established for the specific limit state; this model should incorporate appropriate variables allowing for the uncertainties with respect to actions, the response of the structure as a whole and the behaviour of individual elements of the structure. Further, the significance of the level of workmanship and control should be incorporated. Using such models should permit design, for the different limit states, to acceptable degrees of safety or structural reliability.

Limit state design can therefore be considered as a decision process in which various uncertainties have to be accounted for in assessing the design variables in order to obtain an acceptable failure probability.

3.2 - LEVELS OF LIMIT STATE DESIGN

In the design process it is possible to identify three levels at which the structural safety may be treated and, hence, the design could be carried out; these are:

Level 1: A design method in which appropriate levels of structural reliability are provided, on a structural element (member) basis, by the specification of a number of partial safety factors. Characteristic values are given as functions of mean values, coefficients of variation and distribution types or are assessed on available data and experience. The partial safety factor in a Level 1 method may be derived from Level 2 for any discrete class of structure and can be made identical to Level 2 methods if they are appropriate continuous functions of the means and variances of the basis variables, related to standardised types of distribution, and the safety level. Practical Level 1 methods may be considered as a discretisation of this continuous function.

Clearly Level 1 is, and should continue to be, the basis for most design codes. Simplifications within Level 1 are possible and indeed desirable in the presentation of the various clauses.

Level 1: a semi-probabilistic process in which the probabilistic aspects are treated specifically in defining the characteristic values of loads or actions and strengths of materials and these are then associated with partial factors, the values for which, although stated explicitly, should be derived, whenever possible, from a consideration of the probability aspects.

Level 2: a design method incorporating safety checks only at a selected point (or points) in the data space - rather than as a continuous process. A Level 2 method involves the identification of this safety checking point by a suitable algorithm and the idealisation of the failure boundary in that region. Reliability levels can be defined only by safety indices or equivalent 'operational' probabilities and not in a relative frequency sense.

Formulation of the problem should preferably be made in input rather than output space (i.e. in the space of the functionally independent or 'basic' variables), as this avoids further first order approximations and results in an invariant measure of reliability.

Level 2 should be used principally in assessing appropriate values for the partial safety factors in Level 1; hence it is intended primarily as a tool for code drafting committees. In certain specialised fields it may be the most appropriate design procedure e.g. pylons for overhead electricity cables.

Level 2: a design process in which the loads or actions and the strengths of materials and sections are represented by their known, or postulated distributions, (defined in terms of relevant parameters such as types, mean and standard deviation) and some reliability level is accepted. It is thus a probabilistic design process (see Appendix I).

Level 3 represents a design process based upon an 'exact' probabilistic analysis for the entire structural system, using a full distributional approach, with safety levels based on some stated failure probability interpreted in the sense of relative frequency.

4 ACTIONS

4.1 - DEFINITIONS

In principle, an action is the cause of forces or deformations; in practice only the forces or deformations can be introduced into the calculations. The magnitude of the action-effects also depends on other parameters (for example geometric imperfections) which are not termed actions.

Sometimes it may be useful to distinguish between:

elements of an action (or elementary actions), which can be considered to be independent; and components of an action, which cannot be considered to be independent.

To facilitate calculation of design actions-effects, it may be convenient to regroup several elementary analogous actions into one composite action or to resolve certain actions into a sum or difference of several components.

Actions may be further classified according to whether they are, for example, bounded or unbounded, of short or long duration, and dependent or independent of human activities.

An action is an assembly of:

concentrated or distributed forces
(direct actions);

or

imposed or constrained deformations
(indirect actions);

applied to a structure due to a single cause.

An action is considered to be a single action if it is stochastically independent, in time and space, of any other assembly of forces, or imposed or constrained deformations, acting on the structure.

4.2 - QUALITATIVE CLASSIFICATION OF ACTIONS

Actions may be classified, according to their variation in time, or space, or according to their dynamic nature.

4.2.1 - Classification of actions according to their variation in time

To define the representative values of actions and to determine rules of combinations, the actions may be classified according to their variation in time.

Permanent actions include the selfweight of structures (except possibly during phases of construction), the weight of any controlled superstructure, forces applied by earth pressure excluding the effects of moving loads applied to the ground, prestress, deformations imposed by the mode of construction, actions resulting from shrinkage of welds and concrete and, in certain cases, the forces resulting from water pressure. Support settlement and mining subsidence, evaluated in terms of available methods and information, may, in general, be regarded as permanent actions.

Variable actions include the "working loads" (loads due to use and occupancy), the self-weight of structures during certain phases of construction, erection loads, all moving loads and their effects, forces resulting from wind, snow, ice accretion, earthquakes in regions habitually exposed to them, from water generally, and temperature and its effects.

Additionally, for certain types of structure, special loads, in excess of those used in defining the variable actions, are known to be possible and these should be treated in design with reduced partial safety factors.

Accidental actions include impact forces, explosions, subsidence of subsoil, avalanches of rocks or snow, tornados or earthquakes in regions not normally exposed to them; they are only relevant where the estimated value of the force is neither negligible nor so large that it is unreasonable to assure the integrity of the structure.

Thus, there are:

permanent actions, for which variations are rare (but with likely occurrences of long duration), or negligible in relation to the mean value; or those for which the variation is in one sense and the actions attains some limiting value;

variable actions, for which variations are frequent or continuous, or not monotonic, and not negligible in relation to the mean value;

accidental actions, the occurrence of which, in any given structure, and with a significant value, is unlikely during the reference period, but the magnitude of which could be important for certain structures. They are usually assigned nominal values in assessing the resistance of the structure to them.

Examples and consequences of such classifications are given in the Appendix No. 3.

A load case is defined by fixing the configuration of each of the free actions, for example by means of influence surfaces. Their random magnitude is taken into account by application of the rules of combination (c.f. 10.3).

Free actions cannot be defined by a unique variable, without some idealisation.

In some cases, it is necessary to distinguish within fixed actions ~~and~~ those which are movable or act in a probabilistic way at certain points or on certain part of structures.

In such cases and in the absence of more detailed study, it is generally accepted to consider as different elementary actions, those applied to points or parts recognised, a priori, as the most unfavourable, and those applied to other parts.

Not only variable and accidental actions, but also permanent actions can be fixed or free; for example, the weight of partitions in a building must generally be considered as free, but the weight of the pavement on a bridge can generally be considered as fixed.

4.2.2 - Classification of actions according to their variation in space

To define the load cases to be considered, the actions are divided into two groups:

Fixed actions, whose distribution over the structure is unambiguously defined by deterministic parameters and, possibly, one random parameter. The magnitude of a fixed action may change with time.

Free actions, which may have any arbitrary distribution over the structure within given limits.

Actions not falling within these two groups can be considered to consist of a fixed element and a free element.

4.2.3 - Classification of actions according to their nature

Actions may be of two types:

static actions, which do not cause significant acceleration of the structure or structural member;

In certain cases, the magnitude of an action is dependent on the behaviour of the structure.

In general, most actions may be considered as static actions, taking account of dynamic effects by increasing the magnitude of the actions. Where this is not the case, a special treatment of safety may be required covering the dynamic response of the structure.

For the various situations, relevant representative values for the various actions should be defined; this is particularly the case for the many temporary situations arising during construction.

dynamic actions, which cause significant acceleration of the structure.

Whether or not an action is regarded as a dynamic one is thus dependent on the structural response although the dynamic character is correlated with variation in time of the action.

4.3 - ACTIONS AND SITUATIONS

For convenience in covering all phases in the life of a structure i.e. during construction, normal use and possible misuse, a number of situations may be suggested:

- (a) a permanent situation, the duration of which is of the same order as the reference period, or life, of the structure;
- (b) temporary situations, the durations of which are much less than the reference period, or life, of the structure. These may be either:
 - (i) transient situations, the probability of occurrence being high with their duration being often random;
 - or (ii) accidental situations, the probability of occurrence being very low with their duration being, generally, very short.

The properties of the materials and their statistical variations should be obtained from tests on appropriate standard test specimens. These properties, related to the standard test specimen, should be converted to the relevant properties of the actual material in the structure by the use of conversion factors or functions. The uncertainty of the properties of the material in the structure may be derived from the uncertainties of the standard test results and of the conversion factor or function.

If the strength of the material can be assessed prior to its being incorporated in the structure, the characteristic strength can be evaluated on the basis of an adequate statistical evaluation of the results available.

Where this is not possible, because the material will be produced on site, the achievement of the characteristic strength specified should be ensured by adequate production control and acceptance procedures. In certain cases, it may be necessary to stipulate upper and lower characteristic strength values.

6 GEOMETRICAL DATA

In design, account should be taken of the possible variation of the geometrical data. In most cases, the variability of the geometrical data may be considered to be small, or negligible, in comparison with the variability associated with the actions and the material properties.

Hence, in general, the geometrical data may be assumed to be non-random and as specified in the design.

Where the deviation of certain of the geometrical data from the prescribed values may have a significant effect on the structural behaviour and the resistance of the structure, these should be considered as random variables; the parameters of their variability being determined from the prescribed tolerance limits.

7 METHODS OF ANALYSIS

7.1 - GENERAL

The methods of analysis used in assessing compliance with the requirements of the various limit states should be based on as accurate a representation of the behaviour of the structure as is practicable.

Consideration of the range of possible combinations and configurations of actions is necessary to ensure that the most unfavourable action effects are treated.

For certain non-linear problems, the level of the actions at which the analysis is performed (so-called level of linearisation) may need to be adjusted to ensure a more accurate assessment of the response of the structure and, hence, of the action effects.

In interpreting the results from model tests and in predicting the behaviour of the prototype structure care should be exercised to ensure that all the relevant aspects of safety and serviceability are treated. Where, in the model test, some particular phenomenon is not covered directly, it will be necessary to deal with it by some other procedure involving calculation or judgement.

In this type of testing it is important to ensure that the likely variability of all relevant effects is covered in the testing programme so that the treatment of the safety is consistent with that defined for the conventional procedures set out in this code.

7.2 - ANALYSIS - ULTIMATE LIMIT STATE

Plastic, non-linear and linear elastic theory may be applied depending on the response of the structural material and the structure to load and imposed deformations.

7.3 - ANALYSIS - SERVICEABILITY LIMIT STATES

Normally elastic methods of analysis will be appropriate for these limit states having due regard to the properties of the constructional material.

7.4 - MODEL ANALYSIS AND TESTING

A design may be deemed satisfactory on the basis of results from an appropriate model test coupled with the use of model analysis to predict the behaviour of the actual structure, provided the work is carried out by Engineers with relevant experience using suitable equipment.

7.5 - EXPERIMENTAL DEVELOPMENT OF ANALYTICAL PROCEDURES

A design may be deemed satisfactory if the analytical or empirical basis of the design has been justified by development testing of prototype units and structures relevant to the particular design under consideration.

This demonstration is, in principle, essentially of an experimental order. It can consist of logical deductions on the basis of known and sufficiently established results. The analogous deductions based on observation of the behaviour in service of works built with the aid of similar material or components can be retained as one of the elements of appraisal. The correct application of the principles implies that sufficient tests should be performed to enable one to define the properties of the materials or components by characteristic values, and to appraise the values to be retained for the coefficients γ_m and γ_f (see Section 10).

The technical conditions of the Agrément can concern not only the fabrication but also the placing, and can describe the corresponding controls.

8 GENERAL CONDITIONS FOR USE OF MATERIALS AND COMPONENTS

8.1 - STANDARDISED AREA

The codified uses of standardised materials are covered in Section 9 and in the other Volumes relating to particular materials.

8.2 - MATERIALS AND COMPONENTS IN THE NON-STANDARDISED AREA. NON-CODIFIED USES OF STANDARDISED PRODUCTS.

8.2.1 The use of new or non-standardised materials or components, and the non-codified uses of standardised products can be authorised subject to the reservation that it can be demonstrated that they offer the required safety in the sense of Section 1.

8.2.2 The principles for determining safety, enunciated in the preceding sections, apply in full to these materials and components.

8.2.3 The authorisation can either concern a definite application of isolated character; or assume a general character within the framework of the procedure called Agrément, defined below.

8.3 - AGREEMENT

Agreement is a notice of general scope, acknowledging at the level of principle and within the limitations of use envisaged, the aptitude for use of a non-standardised product, or process, corresponding to certain definitions and specifications.

It may be noted that in the standardised area the Standards and Codes take the place of Agrément.

It is declared by the competent authority within the framework of the directives formulated in 8.2.

It implies regard for technical conditions on which its issue is possibly dependent.

It can depend on the bringing into action of a procedure of Certification of conformity such as is defined in 9.5.1.

It then takes the name connected and marked Agrément.

9 CONTROL AND ACCEPTANCE OF MATERIALS AND PRODUCTS

9.1 - GENERAL

9.1.1 The design of structures includes a specification of the requirements for the properties of the structural materials or products, for the manufacturing methods and for construction. Frequently reference may be made to relevant National and International Standards.

9.1.2 The properties of materials and products are subject to random variability which cannot be forecast precisely at the time of the design. Furthermore, the information on which the production process must be judged contains various uncertainties resulting from the variabilities in sampling and testing. Considering these uncertainties, it is necessary to establish decision rules which adequately take account of the requirements for the safety of structures and the cost of control.

The quality of the materials and products should be specified in terms of statistically defined values (characteristic values) in the probability distributions of one or, alternatively, several properties (e.g.

For the strength of materials the characteristic strength f_k , may generally be taken as the 5% fractile.

The materials or products made and tested in large quantities (e.g. bricks, concrete blocks, etc.) may be classified by means of the characteristic values (e.g. strength classes for concrete, steel, bricks, blocks; stress grades for timber). Somewhat different criteria should be defined for products of large size which can only be tested on a small number

strength, deformation, geometrical deviations, etc.,) of the material or product. The sampling procedure, the shape and size of the samples, their treatment and the methods of testing should be specified.

The properties are to be assessed by tests of attributes or measurements by sampling during the manufacture of the materials or products themselves or on site.

9.1.3 In general, the presentation of the characteristic value as a fractile is sufficient:

$$x_k = F^{-1}(p_k) = m + k \sigma$$

where

x_k = the characteristic value

$F^{-1}(p_k)$ = the inversion of the probability distribution function $F(x)$

p_k = the probability of x_k not being reached or being exceeded

m = the mean value of the population of values

σ = the standard deviation of the population

k = the standardised variable to the probability p_k belonging to F .

9.1.4 The materials or products may be classified in different classes of quality. The number of classes should be kept as low as possible, but should allow adequate freedom in design. The upper limit to the number should be controlled by limitations of statistical methods.

9.1.5 In principle there are three types of control:

- Initial Tests

Tests for estimating the properties of the material or product.

- Production Control

Tests to assess stability and control of the production process.

- Quality Control (Compliance Control)

Tests to decide whether the material or product satisfies the requirements.

These types of control should be carried out independently of each other; the responsibilities should be defined clearly.

The tests may be carried out according to demand by the manufacturer (internal control) while the results of the internal control may be judged by an independent organisation (external control).

These controls may be effected and sanctioned by delivery of the certificate of conformity mentioned in 9.5.1.

9.2 - INITIAL TEST

The initial test serves to estimate the order of magnitude of the properties attainable with the chosen basic materials and, if necessary, with the available production equipment, the personnel and the relevant conditions of manufacture. In special cases, e.g. for the testing of natural elements, the initial test serves for classification purposes.

The consistency may, for example, be proved by means of control cards.

If no precautions are taken against the occurrence of instationary developments the proof of the constancy of the production process is not given.

Suitably installed measuring and control systems can considerably influence the statistical parameters of the product. The variability of the production process can be noticeably reduced.

The amount of quality control has to be kept small for economic reasons. Therefore it is recommended to base the decision on pre-information, e.g. on the standard deviation of the production process.

Two-step testing plans require less random samples.

If the quality is defined as a lower fractile of the population, it is in general convenient to use a decision rule of the type (\ddagger):

$$d(z) \begin{cases} (z_G \leq z: \text{acceptable} \\ (z_G > z: \text{rejection} \end{cases}$$

$$\text{Where } z = z(x_1, x_2, \dots, x_n) = \bar{x}_n - \lambda s_n$$

$x_1 = i.$ element of the random sample

$z = z(x_1, x_2, \dots, x_n) = \text{acceptable function}$

$\bar{x}_n = \text{arithmetic mean of the random sample of size } n$

$s_n = \text{standard deviation of the random sample of size } n$

If the standard deviation of the production is known,

$s_n = \sigma$ may be used.

9.3 - PRODUCTION CONTROL

The production control serves to prove long-term consistency of the production process as well as consistency for production planning with respect to fulfilling the requirements.

9.4 - QUALITY CONTROL

Quality controls serve to decide whether the materials or products satisfy the requirements.

In the quality control process a prescribed number of samples has to be taken independently and at random, these have to be treated and tested in a prescribed manner.

A prescribed number of successive test results has to be set up in one or more acceptance functions. With the aid of a previously agreed decision rule, which contains this acceptance function as well as the appropriate acceptance limits, the decision on acceptance or rejection is made.

λ = acceptance factor

z_G = acceptance limit

(‡) Alternative decision rules are acceptable, if they show approximately the same test characteristic. If "less sufficient" acceptance functions are used, the increased size of the random sample necessary for a decision has to be obtained by an increase in the sampling rate.

Preferably, the acceptance limit has to be given as a linear function of the characteristic value; if necessary, also of the standard deviation. The acceptance limit, z_G , and the relevant parameters n , λ , have to be determined in such a way, that - with regard to the quality to be offered and the previously agreed consequences of negative decisions - it is sufficiently assured that the qualities offered and accepted come up to the requirements of the design engineer. This can be described by a test characteristic which contains the operational characteristic of the decision rule and "a priori" information on the qualities to be offered.

Both in the quality control and in the re-tests, taking into account further information e.g. from measurements of other properties correlatively connected with the chosen characteristic, may lead to a considerable reduction of the total sample size. Such information is to be considered by the application of Bayes' statistics.

In the case of testing by attributes the permissible number (acceptance number) of defectives has to be determined in comparison with the total number of values to be tested.

In the case of negative decisions the amount of material corresponding to the decision may be either refused, reclassified or submitted to further tests (re-tests).

In this case, it is necessary that the tested characteristic of the material is identical or at least strongly correlated, to the characteristic tested first. Then the amount of material under consideration can be finally accepted or rejected.

The permanent character of this agreement does not signify that it is irrevocable.

The Standards, Codes or Agreement establish the consistency of this self-control.

9.5 - CERTIFICATION OF CONFORMITY AND ORIGIN

9.5.1 - Certification of conformity

One designates in this way the agreement of permanent character given to the use of a given product originating from a fixed centre, and sanctioning the statement that this product satisfies the imposed specifications constantly.

Its conferment depends on the exercise of his own control by the producer and on the verification of this control by an organisation independent of him and recognised by the competent authority.

This self-control must have the effect of maintaining at a suitable level the statistical risk called "of the purchaser" (risk of the second kind).

Certification can be sanctioned by putting a mark on the product.

9.5.2 - Certificate of origin

One designates in this way the simple attestation issued by the manufacturer who has made the product or component by himself, and corresponding to the specifications imposed. It does not imply the exercise of control by a third authority.

10.1 - GENERAL

The variability of the actions on a structure is taken into account by defining these in terms of characteristic values; where the necessary data are available these characteristic values are based on a statistical interpretation of that data; where data are not available they are based on an appraisal of experience and, possibly, forecasts of the implications of future developments.

The variability of the strengths and other properties of the construction materials are treated by defining characteristic strengths (and, hence, properties), related to some standard test specimens and procedures, on a statistical basis.

Two types of partial safety factors are introduced, one for the strength of materials and/or elements and the other for the actions or action effects; these partial safety factors γ_m and γ_f vary depending upon the materials, the type of action, the nature of the structure, and its use, and the importance and the consequences, both in human and economic terms, of the limit state being considered. Thus, the design action or action effects are taken as, or derived from, $\gamma_f F_k$, where F_k is the characteristic action, while in the analysis of sections within the structure the design strength is obtained by dividing the characteristic strength by γ_m i.e.

The partial safety factors, γ_m and γ_f , while relevant to all limit states, are primarily relevant to the ultimate limit state. Since it is the safety aspect that is being treated, the design process involves the checking of the structure to ensure that the design actions or action effects can be sustained by the structure when, at critical sections, the design strength of the materials is available. In certain cases, either in defining an action or in deriving the resistance of a member or structure, it may be necessary to define geometrical parameters and tolerance limits (Δ) on them. This will only arise when the particular parameter is of major significance since normal variations in dimensions should be covered by the γ_f and γ_m partial safety factors.

design action (or action effect)

$$= f_{f,k}^F \text{ (or } S(\gamma_{f,k}^F))$$

design strength of sections

$$= \text{function} \left(\begin{array}{l} f \\ \left(\frac{k}{\gamma_m}\right) \end{array} \right)$$

and, possibly, certain geometrical design parameters a_d

$$= a_n + \Delta.$$

The partial safety factory γ_f should be considered as a function of three factors γ_{f1} , γ_{f2} , and γ_{f3} , where:

γ_{f1} takes account of the possibility of unfavourable deviations of the actions from the characteristic values;

γ_{f2} (ψ_0) takes account of the reduced probability of combinations of actions all at their characteristic value; it is thus a combination factor for actions and not a safety factor;

and γ_{f3} takes account of possible inaccurate assessment of the action effects and their significance on safety and variations in the dimensional accuracy achieved in construction, as they affect the action effects.

The partial safety factory γ_m should be considered as taking account of:

the possibility of unfavourable deviations of the strengths of materials or elements from the specified characteristic values;

The breaking down of the partial safety factor γ_f is clearly necessary to enable rational and consistent values for the individual factors to be defined. Further, since γ_{f1} and γ_{f2} are related specifically to the loads or actions, and their combinations, the values derived should obtain irrespective of the constructional material. γ_{f2} takes the value ψ_0 for the ultimate limit state and ψ_1 or ψ_2 for the serviceability limit state. (see 10.3). γ_{f3} , however, is clearly related to the construction material, the design and construction process and the significance of the particular limit state for the material and structure involved.

It also has to take account of the response of the structure to loads or actions and the possibility or redistribution of action effects arising from that response.

γ_m may also be broken down into γ_{m1} and γ_{m2} , or further factors, where this process can be of assistance in treating the various aspects of safety for different materials.

the possible differences between the strength of the material or element in the structure from that derived from control test specimens; the possible local weaknesses in the structural material or element arising principally from, or in, the construction process; the possible inaccurate assessment of the resistance of elements derived from the strength of the material including the variations of the dimensional accuracy achieved in construction as they affect the resistance.

In addition to γ_m and γ_f , a modifying factor, γ_n , may be introduced to adjust either γ_m or γ_f ; γ_n is considered as a function of two factors γ_{n1} and γ_{n2} where:

γ_{n1} takes account of the type of structural failure, namely ductile or brittle

γ_{n2} takes account of the consequences of failure (see 1.4).

This factor, γ_n , takes account of the inherent structural behaviour e.g. structures or parts of structures in which partial or complete collapse can occur without warning, and the seriousness of the consequences of failure.

It should be assumed that the normal situation implicit in existing codes is probably that associated with Serious consequences and Ductile failure.

γ_n should not, however, be used explicitly; it merely serves as a rational way of modifying γ_m of γ_f appropriately.

The definitions are in principle limited to actions whose statistical variation can be represented by a single random variable. However, it is often possible to represent a complex situation by one random variable and deterministic correction factors, by two or more

10.2 - REPRESENTATIVE VALUES OF THE ACTIONS

For verification in the Partial Safety Coefficient Method (Level 1), actions are introduced into the calculations by representative values, i.e. by values corresponding to certain levels of intensity. For different calculations, one may have to distinguish

independent random variables, or by establishing rules for the use of influence surfaces.

It may also be convenient to distinguish representative values during construction from those in service.

For indirect actions the representative values are related to deformations; these may be transferred into forces within the structure.

Nominal values should be associated with the specific representative values which they replace. They are normally obtained from regulations, standards, codes or contract documents and should be stipulated explicitly; for example, the user may assume responsibility for ensuring that certain working loads will not be exceeded.

The object of this sub-classification is to facilitate the treatment of certain phenomena e.g. creep of concrete, and is specific to that treatment. However, permanent actions and quasi-permanent values of variable actions are treated as sustained while accidental actions are treated as transient.

If only one nominal value is given, it is assumed that this value replaces the characteristic value, as well as F_{ser} , and that the usual values of γ_f for actions of the same nature are employed.

In the case of a well defined action (for example passage over a bridge of a precisely known convoy, with controlled position and speed, with no other load) the coefficients γ_f may be reduced slightly, but never below those applicable to the permanent loads.

different representative values of an action, according to its variation in time. The complete set of representative values is as follows:

characteristic values, F_k ;)	
service values, F_{ser} ;)	evaluated
combination values, $\psi_o F_k$;)	mainly on a
frequent values, $\psi_1 F_k$;)	statistical
quasi-permanent values, $\psi_2 F_k$)	basis.

Maximum values and minimum values, which may be zero, are defined when appropriate.

Depending on the variation with time of certain actions, their representative values are sometimes sub-classified as actions of long duration (or sustained actions) or of short duration (or transient actions). In special cases, certain actions have their representative values divided into sustained and transient components.

The above representative values may be replaced by nominal values assessed on a non-statistical basis; such nominal values are in principle multiplied by the same partial safety factors γ_f .

On the basis of judgement and experience; the maximum and minimum values are assessed as the 0.05 and 0.95 fractiles in a population of similar structures; these two values may be replaced by the mean value when neither differs by more than 5% from the mean. Exceptions exist, for example thin members in concrete; in such cases, two values are defined as in (b), by taking into account the single dimensional variability.

The minimum value of the weight of certain non-structural permanent material is often taken as zero. Those responsible for utilisation of the structure will have to ensure that conditions more unfavourable than those foreseen do not occur.

For many structures, only the maximum values of weight of non-structural material and of the active earth pressure, and the minimum value of the passive pressure, are relevant for design.

These values are estimated as the 0.15 and 0.85 fractiles since their scatter, at the critical sections, is practically always simultaneous with that of other actions.

The action of shrinkage during a certain interval of time may be represented by taking into account the nominal values calculated at the beginning and at the end of this interval of time.

10.2.1 - Representative values of permanent actions, G, are either characteristic values or nominal values; the other representative values are, in general, assumed equal to these.

- (a) The selfweight, G_o , of structures is represented by unique nominal value calculated from the drawings of the project and the mean unit weight of the materials
- (b) The weight of non-structural permanent material is represented by two nominal values, a maximum and minimum, assessed by taking into account all variations which are reasonably foreseeable.

In the present state of knowledge, the actions of earth pressure are represented in the same manner.

- (c) The actions of prestress may be represented by two characteristic values, a maximum and minimum; these values depend on the time elapsed since prestressing.
- (d) The deformations imposed by the mode of construction of the structure, by shrinkage, and the forces resulting from a practically constant level of water, are normally represented by unique nominal values. However, the shrinkage varies with time.

Support settlement is generally a composite action representing the global effect of the settlements of various supports. Mining subsidence is generally a succession, sometimes complex, of several forces or imposed deformations. Consideration should be given to possible differential settlement which may be positive or negative.

Some of the values, especially the minimum ones, are often zero or negligible. Others can be unified when their difference is negligible.

The method presented in Appendix 2 represents only the present stage in the development of knowledge.

The majority of actions are not well known and, hence, it is not possible to consider their idealised distribution as sufficiently representative for the derivation of characteristic and extreme values; such values defined by a given fractile or given period of return depend mainly on the idealisation chosen. These values are mainly associated with ultimate limit states.

However, this method is an improvement on previous methods of deriving the desired values. It is estimated that:

for a scalar action, the distribution of which is well known and with a coefficient of variation of the maximum in 50 years not much greater than 0.2, a mean return period of about 120 years would be appropriate;

for a vectorial action in any direction, satisfying the same conditions, a mean return period of about 50 years would be appropriate.

(e) The actions due to settlement and mining subsidence are represented by two nominal values, a likely maximum and a minimum which is often zero.

10.2.2 - Representative values of the variable actions,

Q (or F_{var}), may be, in general, all those given in 10.2.

(a) Choice of characteristic values Q_k ; with the current state of knowledge, the characteristic values should be chosen by a pragmatic method (along the lines given in Appendix 2).

It is clearly possible to choose smaller return periods for the characteristic values, but the values of γ_g would then not be uniform and difficulties in assessment would arise. Moreover, in design it is simpler to adopt uniform γ_g values and characteristic values, the return periods for which, although not well defined, have been fixed in relevant loading codes.

These values are associated with serviceability limit states dependent on a single occurrence of such values.

In any case, nominal values may be laid down by a relevant authority.

Usually, one can take as combination values those with a mean period of return equal to about 30 years. These values may be taken into account with a coefficient γ_{f1} equal to 1. Depending on the form in which the load combinations are presented, adjustments may be necessary to the ψ_0 values to ensure that $\gamma_{f1}\psi_0$ is correct (see 10.4).

These values are mainly associated with serviceability limit states dependent on the repeated occurrence of an action. They are not chosen by reference to their probability of occurrence but to their frequency or duration of occurrence.

- (b) Choice of service values, Q_{ser} ; these values are determined in the same manner as characteristic values; however, no reference is made to clauses 3.32 and 2.41 of Appendix 2.
- (c) Choice of nominal values instead of characteristic and service values; for the working loads, when a sufficient statistical basis is lacking, one can take as nominal values the values which the users will be required not to exceed. Nominal values can also be used when an action is bounded.
- (d) Choice of combination values, $\psi_0 Q_k$; these values are those which, in the usual most unfavourable cases, associated with a value $\gamma_{f1} Q_k$ of another action, lead, for linear functions of the two variable actions, to probabilities close to those corresponding to the occurrence of the values $\gamma_{f1} Q_k$ of the other action.
- (e) Choice of frequent values, $\psi_1 Q_k$; these values have to be judged for each type of action and in relation to their significance with respect to the serviceability limit states.

However, for simplicity, it is possible to deviate from such an estimate, provided that the design action-effects are not in this way significantly modified in the sense contrary to safety. These values are associated with performance criteria dependent on sustained actions.

It is possible to reduce these values during certain phases of short duration and in cases where there is control of the values or of the effects of certain actions.

The coefficients of concentration can often be taken as 1.4 and the supplementary overestimate can often be obtained by multiplying by 1.25.

The representative values of provisional permanent actions of the same type as the definitive permanent actions, and of provisional construction, defined in size and position with the same precision as the definitive permanent actions, are as defined in 10.2.1.

The choices are made:

Either by a decision by competent authorities, determining the level of safety in terms of various criteria of a general nature (notably economic) or by a statement by the engineer that a higher value could only be the result of a gross error by a user.

(f) Choice of quasi-permanent values, $\psi_2 Q_k$; these values are generally determined as the mean value of the action in the course of time.

The following deal with special problems.

(g) Choice of representative values of natural actions in the course of construction (W_{pro} and others); One normally takes the representative values for a mean period of return 50 times less than those accepted in the actual design.

(h) Choice of representative values of site loads, Q_{pro} ; these loads are generally represented, during each phase of construction, by a unique maximum value applied only where their effect is unfavourable; the minimum representative values are zero.

By means of a suitable supplementary overestimate, every maximum representative value is deduced from the most unfavourable probable loads able to be applied during the phase considered, previously increased by a coefficient of concentration and a dynamic coefficient if applicable. Some of them can be represented by nominal values.

10.2.3 - Representative values of accidental actions, F_{acc} , are unique nominal values. These values are chosen as those beyond which there is no longer an assurance of a probability of survival of the structure.

Their service values, their combination values, their frequent values and all their minimum values are considered negligible or zero.

10.3 - COMBINATIONS OF ACTIONS

It should be noted that, in section 10.3, the partial safety coefficient γ_{f3} is not included in the combination rules.

Combinations of actions are assemblies of representative values which, including the coefficients γ_{f1} and ψ , lead to design actions, covering with an acceptable probability the actions resulting from combinations of real values.

A distinction is made between "fundamental combinations" and "accidental combinations".

In the following clauses G_{\max} and G_{\min} designate the unfavourable and favourable permanent actions respectively for the limit state considered; permanent actions represented by a unique value are included in G_{\max} and G_{\min} as appropriate.

10.3.1 - Ultimate Limit States

The combinationa of actions for the ultimate limit should be taken as:

(1) Fundamental Combinations

$$1.2 \sum G_{\max} + 0.9 \sum G_{\min} + 1.4 (Q_{1k} + \sum_{i=2}^n \psi_{oi} Q_{ik})$$

where Q_1 is the basic action in the combination;

$\psi_{oi} Q_{ik}$ is the combination value of the accompanying action;

The combinations are, in general, relevant to the ultimate limit states defined in 2.2 (a)-(d) although certain modifications may be necessary (notable for static equilibrium and buckling).

This formula is pragmatic and practical; the values of γ_{f1} are valid in the vast majority of cases. Certain modifications may be necessary or useful, in particular;

when a permanent action, with a relatively large dispersion, dominates in the combination e.g. earth pressure on a retaining wall, it may be necessary to increase $1.2 G_{\max}$ to $1.3 G_{\max}$;

when the maximum basic action has a coefficient of variation less than 0.1, it is possible to reduce the coefficient 1.4; the reduction may be to 1.3 when the coefficient of variation is zero e.g. for water pressure in a full reservoir.

When the distributions of G and Q do not contain irregularities (multi-modal for example) and their coefficients of variation are not more than those for the common actions (c.f. Appendix 3 for the variable actions), γ_{f1} can be considered as giving defined fractiles of the actions.

In this case the coefficient γ_{f1} applied to the combination values may be reduced to 1.1. In other cases, γ_{f1} is an element of the total safety and includes, in effect, part of the uncertainty normally included in γ_{f3} .

In the application of the formula, with or without modifications, different basic and accompanying actions should be considered to obtain the most unfavourable combinations for the limit state being studied. In general only two accompanying actions need be considered.

It should be noted that the presentation of the combinations is symbolic since the actions may be direct or indirect.

When using various methods to define the envelope of a given action effect it may be convenient to provide the envelopes for $1.2 \sum G_{\max}$ and $0.9 \sum G_{\min}$ adding that for the variable actions Q to whichever is appropriate.

Suggested values for ψ_0 are:

Action	ψ_0
1 Associated with	
Domestic Buildings)	
Office Buildings)	0.5
Retail Premises)	
Parking Garages	0.6
2 Associated with	
Wind	0.55
Snow	0.55
Wind and Snow	0.55 and 0.4

This combination covers both an accidental action in both permanent and transient situations (i.e. excluding the accidental situation) and permanent and variable actions (i.e. excluding accidental actions) in accidental situations.

(2) Accidental Combinations

$$F_{acc} + G_{max} + G_{min} + \psi_1 q_{1k} + \sum_{i=2}^n \psi_{2i} q_{ik}$$

where F_{acc} is the basic action in the combination or zero.

For an accompanying variable action with a quasi-permanent value $\psi_2 q_k$ which is not zero or negligible $\psi_{oi} q_k$ should not be less than $\psi_{2i} q_{ik}$ in (1) or (2).

10.3.2 - Serviceability Limit state

It is not possible to state categorically the number of actions to be considered in the various combinations since this has to be judged dependent on the type of structure, constructional material and which criterion is being assessed.

The suggested values of ψ_1 and ψ_2 are given, for certain actions, in the Table below.

Table of suggested values for ψ_1 and ψ_2

Action	1	2
1. Associated with:		
Domestic Buildings	0.7	0.4
Office Buildings	0.8	0.4
Retail Premises	0.9	0.4
Parking Garages	0.7	0.6
2. Associated with:		
Wind	0.2	0
Snow	Dependent on region	

The combinations of actions for the serviceability limit state should be taken as

- (1) Infrequent combinations

$$1.0 G_{\text{mean}} + 1.0 F_{1k} \text{ (or } F_{\text{ser}}) + \sum_{i=2}^n \psi_{1i} F_{ik}$$

This combination merely includes all relevant variable actions at their frequent values together with a single action at its characteristic, or service, value.

- (2) Quasi-permanent combinations

$$1.0 G_{\text{mean}} + \sum_{i=1}^n \psi_{2i} F_{ik}$$

where $\psi_{2i} F_{ik}$ represents that value for an action deemed to be of a quasi-permanent nature in relation to the criterion governing the long term performance of the constructional material or structure.

- (3) Frequent combinations

$$1.0 G_{\text{mean}} + \psi_1 F_{1k} + \sum_{i=2}^n \psi_{2i} F_{ik}$$

where $\psi_1 F_{1k}$ represents that value for an action deemed to be of frequent occurrence for the assessment of a particular criterion governing the performance of a constructional material or structure. Clearly, this combination may include also any relevant quasi-permanent actions.

10.4 - THE STRENGTH OF MATERIALS

10.4.1 - General

Normally the probability adopted will be that associated with the 5% risk level. However, the actual value adopted will depend on the material and the processes involved in its manufacture and use as a structural material and their variability.

Clearly, the mean strength, and its associated properties, throughout the structure should be used in analysis; this is, in general, not known and hence it is necessary to utilise the only available information, namely, the specified characteristic strength.

Values for γ_m for different materials are stated in the appropriate volumes of the model code.

The characteristic strength of the material (f_k) should be taken as that value of strength below which only a small percentage of the population of all possible strength measurements is expected to fall. In certain cases, it may be necessary to stipulate upper and lower characteristic strength values.

When analysing the structure, or part of the structure, to determine the action effects within the structure, the properties of the materials may be assumed to be those associated with their characteristic strengths, irrespective of which limit state is being considered.

When analysing any cross-section within the structure, the properties of the material should be assumed to be those associated with the design strengths appropriate to the limit state being considered.

10.4.2 - Ultimate limit state

The design strengths of the materials, f_d , are defined by:

$$f_d = \frac{f_k}{\gamma_m}$$

and γ_m will always be greater than or equal to unity for this limit state.

10.4.3 - Serviceability limit states

The same basic equation relates the design strength to the characteristic strengths as in 10.4.2.

See other Volumes of Model Code for tolerances accommodated by the stated values of γ_m and γ_f . Where a discussion is critical to the response of the structure, it may be considered as a parameter as indicated in 10.1.

In the verification process the design actions (or loads) may be taken as a function of γ_{f1} , ψ_1 , F_k and the introduction of γ_{f3} allows for the method of assessment of the action or loading effects by some analytical procedure; thus, using the notation S for the action effects and R for the resistance of the structure, then

$$S \leq R$$

and, depending on the nature of the problem and the associated method of analysis, this may be rewritten as

$$S(\gamma_{f1}, \psi, \gamma_{f3}, F_k) \leq R$$

or $\gamma_{f3} S(\gamma_{f1}, \psi, F_k) \leq R$

10.5 - GEOMETRICAL DATA

In general, the partial safety factors γ_m and γ_f are chosen such that they cover the effects of deviations of the cross-sections, and similar geometrical data; hence, the design is based on nominal values. The tolerances on the geometrical data relevant to the values of γ_f and γ_m should, therefore, be stated.

10.6 - VERIFICATION PROCEDURES

10.6.1 - Ultimate limit states

The assessed action effects on the structure and the elements of the structure should be checked to see that they are less than or equal to the resistance of the structure, or of the elements of the structure; thus

$$\text{function}(\gamma_{f1}, \psi, \gamma_{f3}, F_k) \leq \text{function}\left(\frac{f_k}{\gamma_m}\right)$$

10.6.2 - Serviceability limit states

The design actions to be considered for this limit state are, for the permanent loads, the characteristic values; for those actions which are only of short term duration, or only part of which may be considered as quasi-permanent, appropriate values less than the characteristic values may be taken; thus

$$\text{design action} = G_k + \sum_{i=1} \psi_i F_{ik}$$

where $\psi \leq 1$ and may be ψ_1 or ψ_2 (see

Practical recommended units are:

- For concentrated or distributed loads and forces
..... kN, kN/m, kN/m²
- For stresses and strengths ... MPa = N/mm² = MN/m²
- For moments , , , kN.m

11 BASIC NOTATION

The Notation used should be in accordance with the Standard Notation established by ISO (ISO standard

12 UNITS

Units used should be in accordance with the "International System of Units, S.I." based on the metric decimal system with seven basic units.

The "Rules for the use of the International System of Units, S.I., in Building" established by ISO should be followed.

INTERNATIONAL COUNCIL FOR BUILDING RESEARCH STUDIES AND DOCUMENTATION

WORKING COMMISSION W18 - TIMBER STRUCTURES

LATERAL BRACING OF TIMBER STRUTS

by

J A SIMON

Council for Scientific and Industrial Research

Pretoria

LATERAL BRACING OF TIMBER STRUTS

by

J.A. Simon Pr. Eng*

SYNOPSIS

Current codes of practice give little guidance on the design of bracing and its effect on the strength of struts. Available information on the variables affecting the behaviour of bracing is given, as well as results from a limited amount of analytical and test work done recently by the NTRI.

1. OBJECT OF THIS PAPER

The object of this paper is not to offer draft clauses on the design of bracing for inclusion in codes of practice, but rather to outline the problem areas and to provide a description of the 'state-of-the-art' to be used as a basis for discussion and future research work. There appear to be conflicting results on the effects of the variables involved, and considerable research effort is required before a realistic code for the design of bracing can be compiled. In the near future, the NTRI hopes to commence a project which will be designed to investigate the problem in more detail.

* Senior Research Officer, NTRI, CSIR, Pretoria, South Africa.
Paper presented to CIB-W.18 meeting, Stockholm, March 1977

2. INTRODUCTION

In a recent study of the causes of failure of timber roof structures in South Africa since 1971, it was found that in at least half of the cases investigated, the failure was directly or indirectly a result of inadequate bracing. Tiled roofs supported by prefabricated trusses, in particular, appear to have been a severe problem. Part of the reason for this is that it is common local practice to lay tiles on battens which are nailed direct to the rafters with no cladding or sheathing between the rafters and battens.

Common assumptions implicit in the design of braced struts are that the battens or purlins constitute an effective lateral restraint and that they themselves are sufficiently restrained from longitudinal movement. The effective length, and hence the allowable compressive stress in a rafter is therefore governed by the spacing of the lateral restraints. As the battens on a tiled roof are much more closely spaced than the purlins on a sheeted roof, the allowable compressive stress in the rafters of tiled trusses is considerably higher than that in the rafters of sheeted trusses, and there is therefore a greater need to ensure their stability. Sheeted roofs by their very nature also have a fair amount of lateral rigidity due to the diaphragm action of the sheeting panels, and have not given much trouble in the past.

Bryant³ has identified five basic bracing requirements which are

- . to provide temporary support for trusses during erection until the rest of the roof structure is complete;
- . to prevent lateral buckling of the rafters by longitudinal restraint of the purlins or battens;
- . to prevent bowing of the tie if the truss should twist or if a reversal of stress due to wind uplift should cause it to buckle;

- . to keep the trusses vertical under wind forces at right angles to them;
- . to prevent horizontal distortion of the whole roof structure by wind forces parallel to the trusses.

It is the second requirement which is generally of paramount importance to the designer.

Inspection of codes of practice reveals that there are few, if any, analytical techniques available for ensuring that the bracing is of adequate strength and stiffness to satisfy these requirements. The stiffness aspect is of extreme importance in timber structures since there must be some relative displacement between the strut and the bracing member before any load can be developed on the connection between these two members. This relative displacement generally results in some additional eccentricity in the strut, and hence an increased lateral force on the bracing. Codes for other materials such as steel are also of little help, since the past conservative 'rule-of-thumb' methods appear to have been adequate to ensure structural stability for those materials. As a result it is often difficult or impossible for a designer to prove analytically that a bracing system which he knows from experience is satisfactory, will withstand the specified lateral loads. Leicester⁴ has made recommendations which relate to the maximum grading imperfections allowed for Australian timbers. These recommendations, which have been included in the latest Australian Timber Engineering Code¹, are attached (see Appendix) and as far as is known have not been backed up by any experimental work.

On the other hand, Bryant³ has produced a number of bracing recommendations which are based purely on experience and 'rule-of-thumb' decisions.

A code of practice for the design of bracing for compression members, whether they be columns, compression rafters or the

compression flanges of beams should give guidance on the following points :

(a) Force on lateral restraints

The design force on lateral restraints will be a function of initial eccentricity, joint stiffness, restraint spacing, and number of restraints. In South Africa as in most other countries the following inadequate clause from the Steel Design Code is used as the basis for bracing calculations :

'The lacing of compression members shall be proportioned to resist a total transverse shear force at any point in the length of the member equal to $2\frac{1}{2}$ per cent of the axial force in the member, which shear force shall be considered as divided equally among all transverse lacing systems in parallel planes'. (BS 449 - 1969)²

According to Leicester⁴ (see Figure 3) the restraint stiffness has an effect on the lateral force only for very low values of restraint stiffness (i.e. stiffness < 50 N/mm). Most connections have a stiffness in excess of this value with the result that according to Leicester, under design loads the lateral force is independent of the joint stiffness. Recent computer simulation studies at the NTRI appear to have contradicted this (see Section 3).

These studies have also contradicted Leicester's claim (Figure 4) that the total lateral force reduces with an increase in the number of restraining members.

(b) Maximum eccentricity

Few timber members are perfectly straight, but have distortion due to twist, spring, bow and cup which will affect both the force in the lateral restraints as well as the force in the strut itself. Grading

rules limit these distortions to a particular value, and an initial eccentricity value is generally included in the calculation of permissible compressive stresses using the Perry-Robertson or similar formula. These two eccentricity values are often not identical. Since trusses are very flexible in a horizontal direction, and since the timber can be built into a truss with some bow remaining, a certain amount of lateral eccentricity is often built into the rafters during erection. Some guidance must be given to a site engineer on the magnitude of the eccentricity he can allow in an erected truss or rafter before it is rejected.

(c) Forces on a braced bay

It is common practice on large truss rafter roofs to construct a 'braced bay' with bracing girders in the plane of the rafters and ties. For the calculation of the forces due to the purlins on this bracing girder, some assumption must be made on the magnitude of the cumulative effect of a number of adjacent trusses on the force in a purlin connecting these trusses..

For example, if there are 20 trusses between braced bays and the force on each purlin due to a single truss is calculated to be F , the following completely different assumptions have been found to be applied by designers for the calculation of the force due to a purlin on the bracing girder :

- . The force is cumulative and is therefore equal to $10F$.
- . The force cannot reach a value greater than $5F$ (our interpretation of Australian code).
- . The force cannot reach a value greater than $2F$ (used by many steel designers). This figure may be less valid for timber than it is for steel where the probability of having the initial eccentricity of a number of adjacent members in the same direction is small.

(d) Effect of roofing materials

Due to diaphragm action, different roofing and ceiling materials can have a marked effect on the rigidity of a roof. Bracing rules for tiled roofs should be much more stringent than those for sheeted roofs where, provided the sheets are firmly attached to the purlins, the sheeting will provide better bracing in the plane of the rafters than almost any other form of bracing. Sheathing and ceilings can also have a beneficial effect, which could be allowed for in a code if some knowledge of the magnitude of this effect was available.

(e) Effect of the restraint stiffness on the load capacity of a strut

The buckling mode of a strut with intermediate restraints is highly dependent on the axial and rotational stiffness of the connection between the restraining member and the strut as shown below.

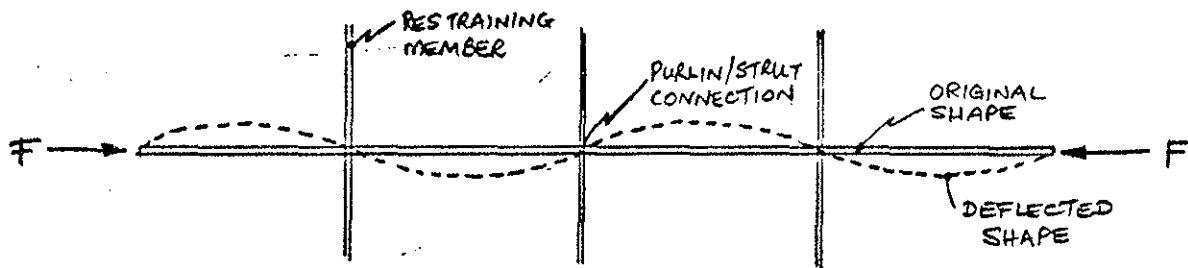

Connections with a high stiffness value

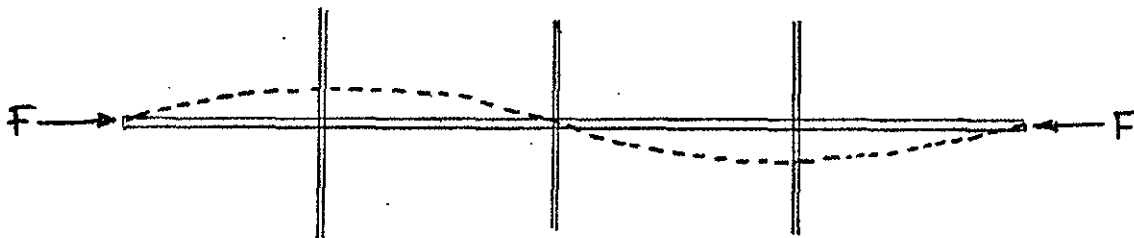

Connections with a low stiffness value

3. WORK BY NTRI

3.1 Computer simulation studies

A number of mathematical models were recently analysed using a stiffness matrix package⁶ in an attempt to investigate the effects of joint stiffness, strut eccentricity, purlin spacing, and number of purlins. These models assumed elastic behaviour of the system.

The results shown in Figures 1 and 2 indicate the following :

- . The 2½ per cent value currently recommended by BS 449 and the South African Standard Building Regulations will yield conservative results (Figure 2).
- . The lateral force is independent of purlin spacing, but is dependent on number of purlins, joint stiffness and initial eccentricity.

3.2 Tests

A series of pilot tests recently completed at Pretoria University⁵ has yielded some interesting results.

Timber struts 2 metres long, planed to cross-sectional dimensions 36 x 111 mm and restrained with 38 x 38 mm purlins were loaded to destruction in an attempt to simulate the behaviour of a rafter in a roof. All struts were machine stress graded in a TRU Timber Grader prior to assembly of the test specimen, and the lateral force on the central purlin was measured by means of a calibrated proving ring. A brief description of the test specimens used and results obtained is given in Figure 5. Load factors were calculated on the basis of the grade stress for the timber, using the Perry-Robertson formula and using the purlin spacing as the effective length for the calculation of slenderness ratio. This assumption is commonly used by local truss designers.

The results of these tests indicate the following.

- . Using the present assumptions, the load factors in braced struts appear to be below the expected minimum value of 2.22.
- . The buckling mode in all cases implies that the effective length used by designers appears to be incorrect since the joints do not have sufficient strength and stiffness to force buckling between adjacent joints.
- . The lateral force in the restraints was more variable than expected, but was of the order predicted by the computer simulation study.
- . If the system behaved elastically, the lateral force in the purlins would be a fixed proportion of the axial force in the strut regardless of the value of this axial force. It was found that the ratio of lateral force to axial force increased with increasing axial force. The values given in Figure 5 are those measured at maximum load.
- . The use of framing anchors at the intersection of the strut and the restraints resulted in only a marginal increase in the ultimate strength of the strut since the stiffness of the large number of small nails used in the framing anchor is roughly equivalent to the stiffness of the few large nails acting alone. The stiffness of the connections was, therefore, not sufficient to develop the predicted ultimate loads.

4. CONCLUSIONS

Implicit in the design of braced struts are a number of assumptions on the degree of lateral restraint offered by the bracing members. The magnitude of this restraining force depends on factors such as initial eccentricity in the strut, number of restraints, and connection stiffness. In many cases connections between rafters and purlins or battens may not have a sufficiently high stiffness to validate the design assumptions. It is therefore possible that rafters and similar members do not always have the factor of safety suggested by the design calculations.

The analysis of the forces in bracing members is currently based on 'rule-of-thumb' calculations resulting in values which bear little resemblance to those actually occurring in the erected roof. Although bracing which has been designed by experienced guesswork rather than by detailed calculation appears to have behaved adequately in the past, it is difficult to prove analytically that it is satisfactory. Some realistic design method, based on the variables involved, must therefore be developed for inclusion in codes of practice.

BIBLIOGRAPHY

1. AUSTRALIAN STANDARDS ASSOCIATION (1975) SAA Timber Engineering Code AS1720-1975. Sydney, NSW.
2. BRITISH STANDARDS INSTITUTION (1969) The use of structural steel in Building. BS 449, Part 2.
3. BRYANT, P.A.V. (1976) Notes on the construction and erection of timber truss roofs. CSIR Special Report HOUT 123, Pretoria, South Africa.
4. LEICESTER, R.H. (1975) Design of bracing systems for timber structures. IUFRO Wood Engineering Group Proceedings, Delft, Holland.
5. SCHUTTE, C.H. (1976) The bracing of timber roofs. Final year project report. Dept. of Civil Engineering, University of Pretoria, South Africa.
6. WASSERSTEIN, L. & J.A. SIMON (1976) The computerised design of timber structures including a description of a program for the analysis and design of plane frames. CSIR Special Report HOUT 125, Pretoria, South Africa.

MODEL ANALYSED:

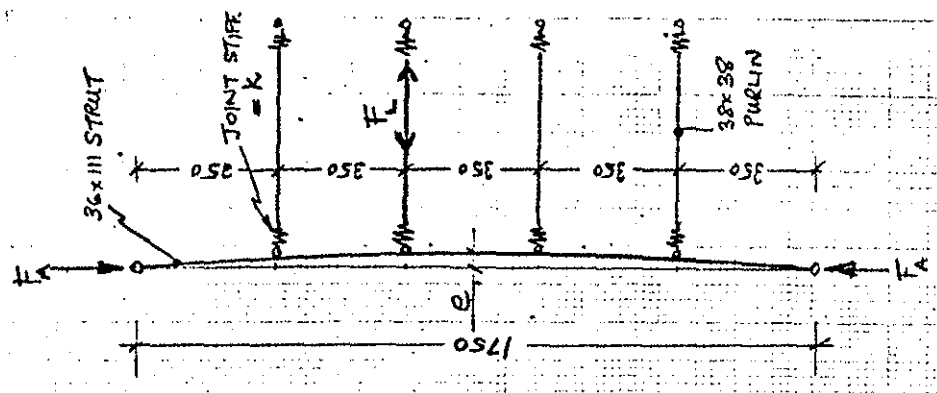
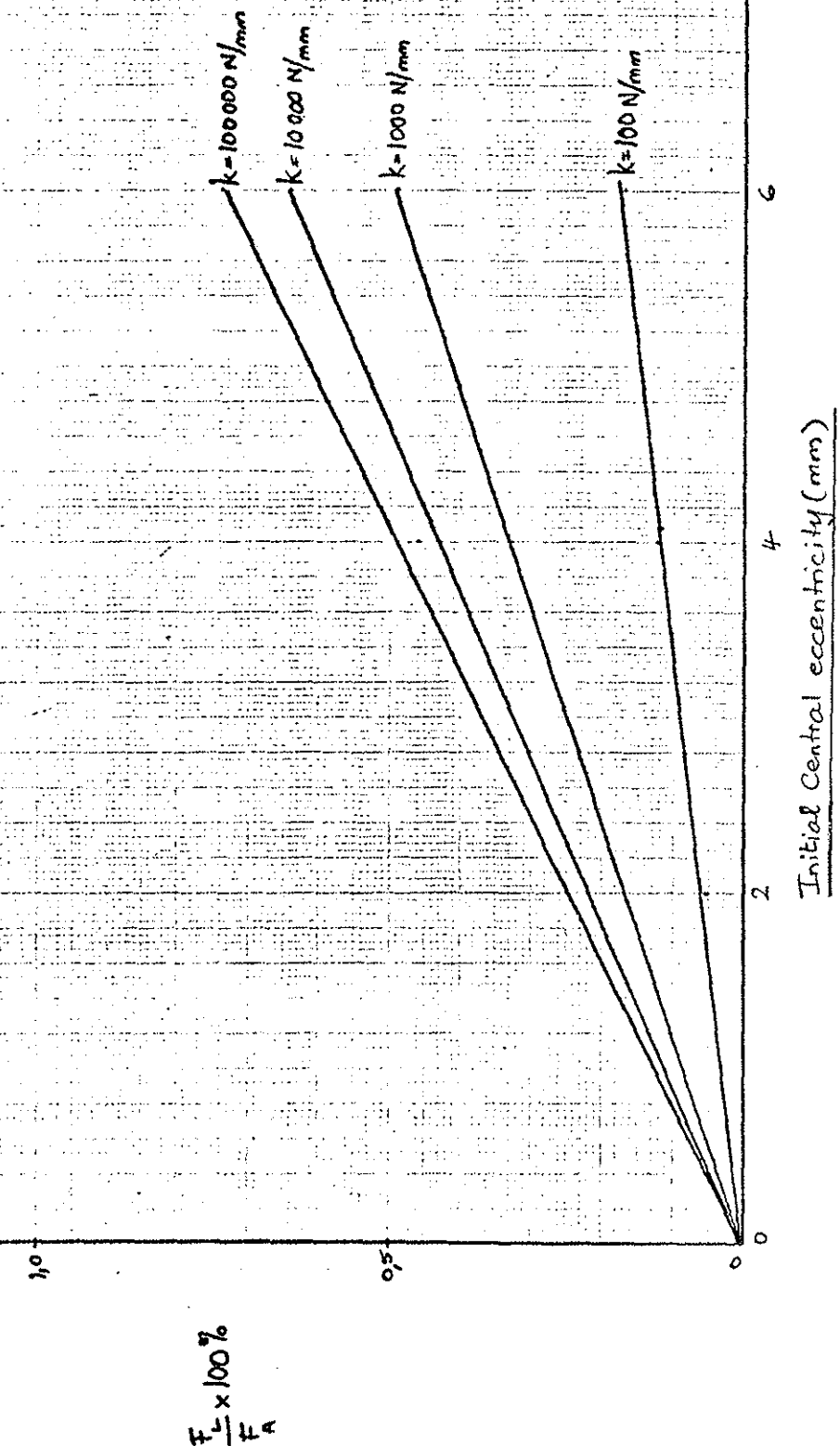

FIG 1: EFFECT OF JOINT STIFFNESS AND CENTRAL ECCENTRICITY ON LATERAL FORCE



$\frac{F_L}{F_A} \times 100\%$

Initial Central eccentricity (mm)

FIG. 2: LATERAL FORCE ON BRACING PURLINS
(COMPUTER ANALYSIS)

— PURLIN SPACING = 350 mm
— PURLIN SPACING = 500 mm

2 1/2% VALUE CURRENTLY ALLOWED BY BS 449

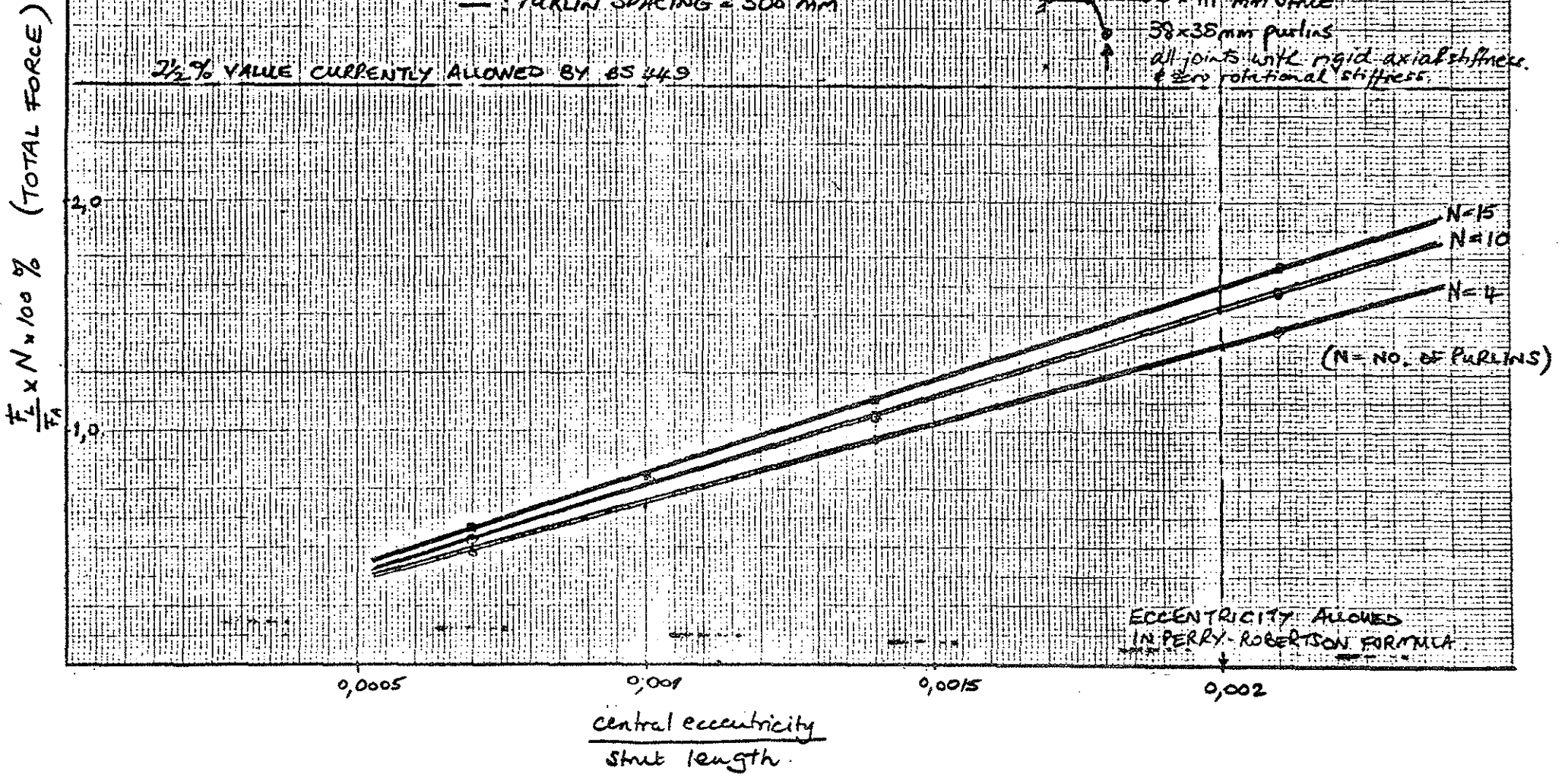
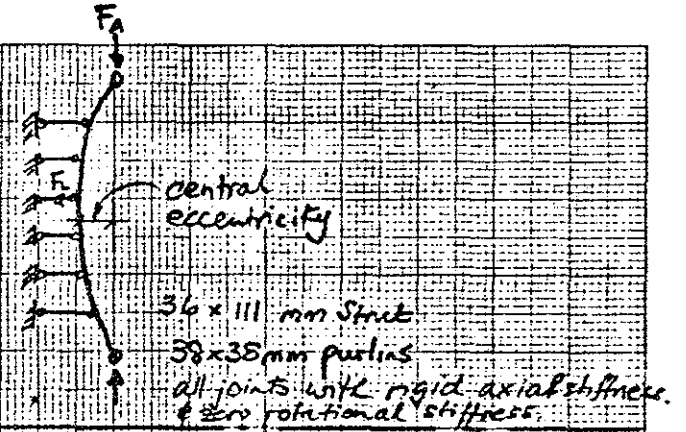

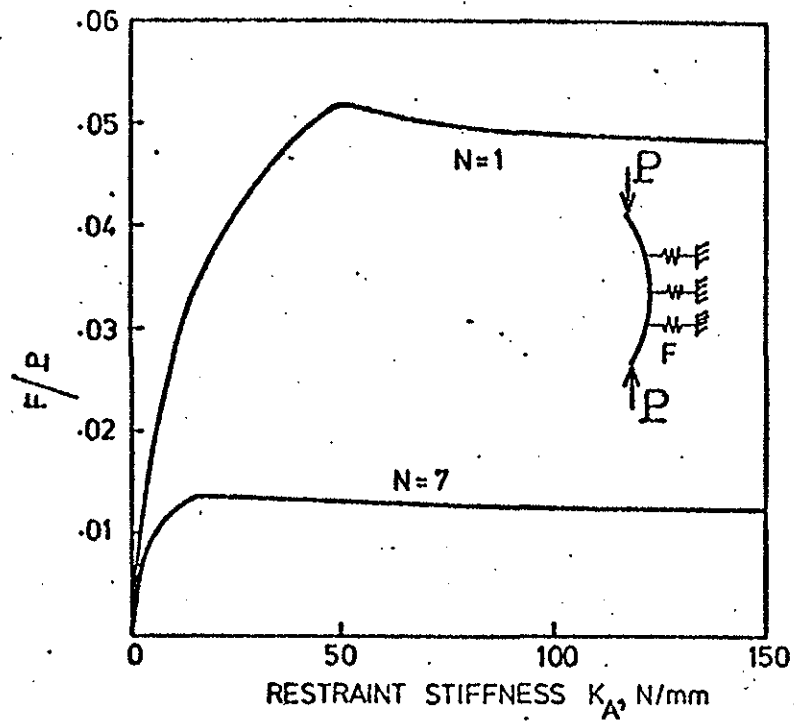

FIG. 3 MAXIMUM RESTRAINT FORCE F AT DESIGN LOAD †

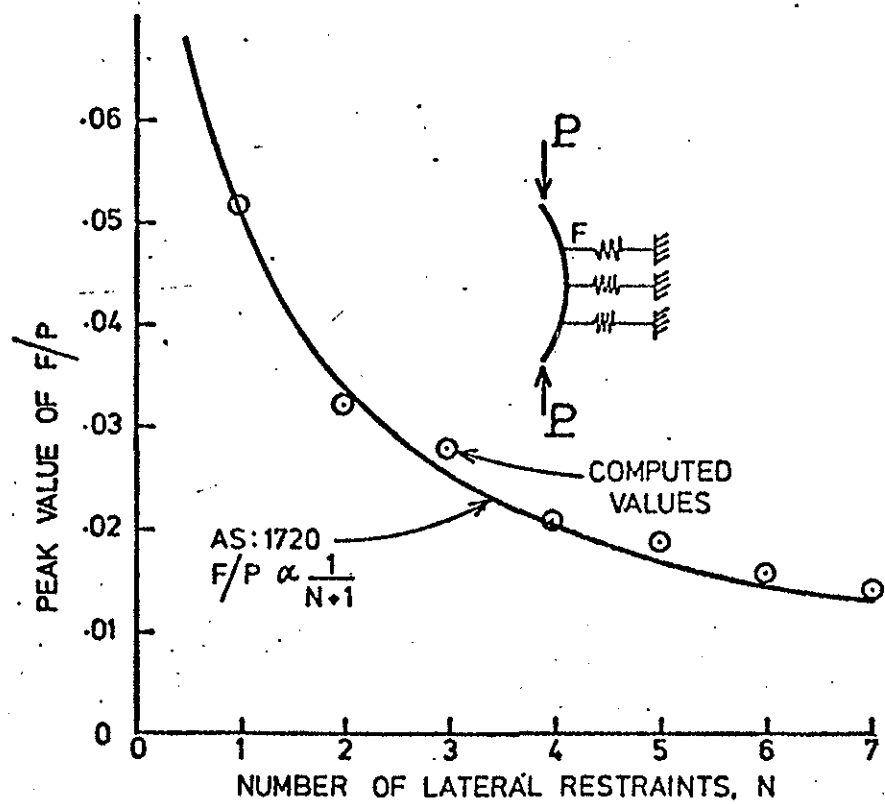
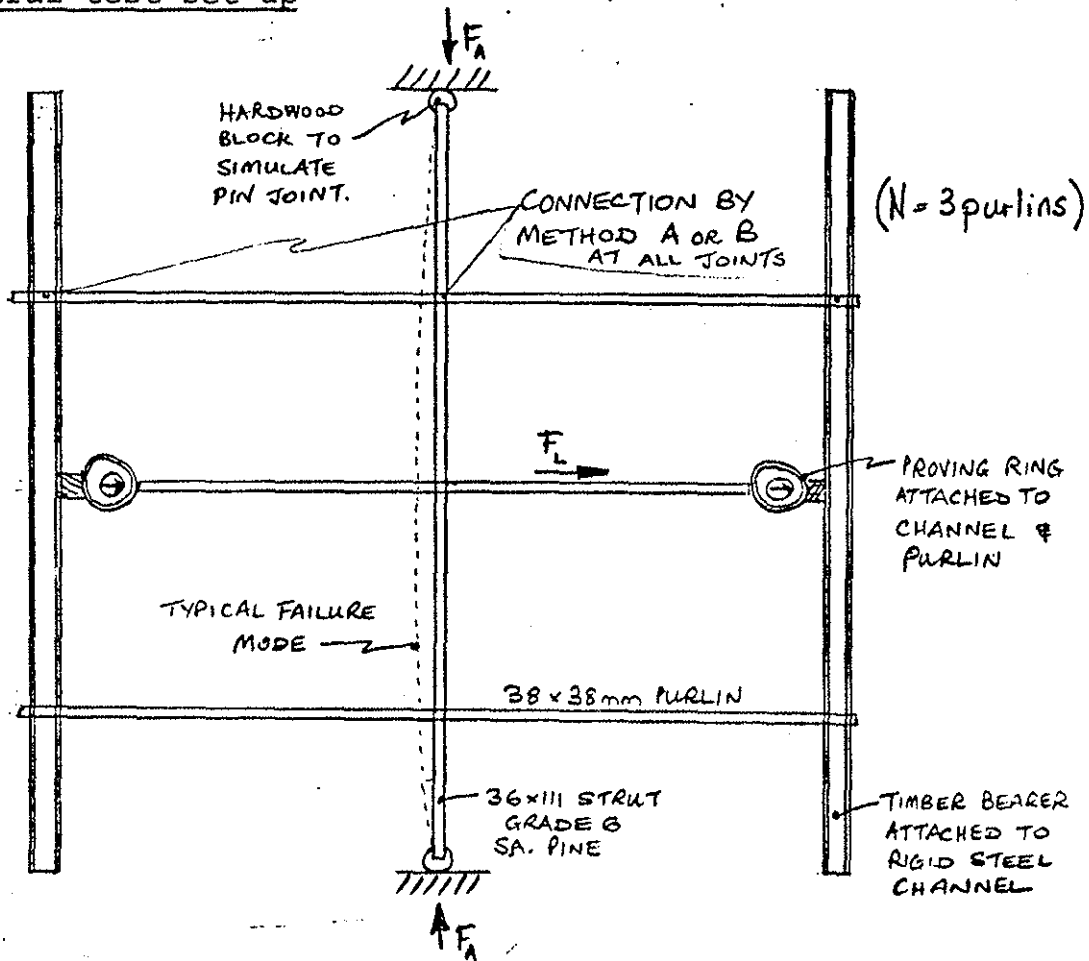

FIG. 4 PEAK RESTRAINT FORCE †

FIGURE 5 : Summary of tests on restrained struts

General test set-up



Connection

Method A = 2 no. 100 mm long nails - skew nailed

Method B = 2 no. framing anchors connected with 8 no. 38 mm long nails.

Tests

Sample no.	Purlin spacing (mm)	No. of purlins (N)	Load factor	$\frac{F_L}{F_A} \times N \times 100\%$
3A1	500	3	1,05	0,777
3A2	500	3	1,59	2,925
3A3	500	3	0,82	0,735
4A1	350	4	1,31	0,624
4A2	350	4	1,51	2,196
4A3	350	4	1,51	0,892
3B1	500	3	1,30	0,261
3B2	500	3	1,30	1,389
3B3	500	3	1,83	0,576
4B1	350	4	1,68	0,420
4B2	350	4	1,45	0,804
4B3	350	4	1,39	0,808

LATERAL AND TORSIONAL BUCKLING RESTRAINTS

The following method may be used for a design of slender beams having equally spaced buckling restraints. The restraint systems considered are either lateral or torsional ones as shown in Fig. D1, where the restraint stiffnesses K_A and K_B are defined as follows:

$$F_A = K_A \Delta_A \dots \dots \dots (D1)$$

$$T_B = K_B \theta_B \dots \dots \dots (D2)$$

where F_A and T_B are the restraint force and torque respectively that occur when the point of attachment of the restraint to the beam undergoes a displacement Δ_A and rotation θ_B . It is assumed that the end of beams are effectively restrained against torsional rotation (see Section E2.1).

Notation to be used in the design formulas are defined as follows:

- $K_{36} = 1.0$ when loads are live loads only
- $= 1.5$ when loads are dead load only and timber is initially dry
- $= 2.0$ when loads are dead loads only and timber is initially green
- NOTE: Values of K_{36} for other conditions may be obtained by linear interpolation.
- $K_{37} = 1.0$ for sawn timber members
- $= 0.4$ for laminated and other carefully fabricated timber members

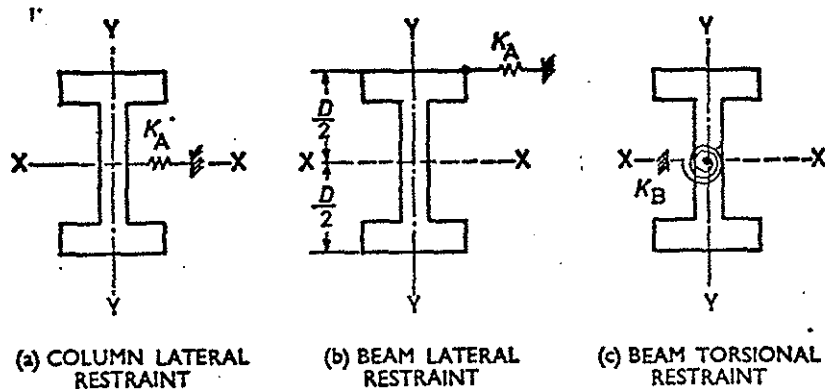

Fig. D1. INTERMEDIATE RESTRAINTS

$$K_{38} = \text{lesser of } \frac{m+1}{2} \text{ and } 5$$

m = number of members supported by each restraint system

n = number of equally spaced intermediate restraints

S_{max} = slenderness coefficient if there are no restraints

S_{min} = slenderness coefficient if the restraints are effectively rigid.

D2 COLUMNS.

D2.1 Load Capacity. In computing the load capacity of a column of length L with n intermediate lateral restraints as shown in Fig. D1 (a), the slenderness coefficient S_3 may be taken as —

$$S_3 = \frac{S_{max}}{(\alpha_1)^{1/4}} \dots \dots \dots (D3)$$

but not less than S_{min} and not more than S_{max} , and where —

$$\alpha_1 = \frac{(n+1) K_A S_{max}^2 L}{2AE} K_{38} \dots \dots \dots (D4)$$

D2.2 Force on Lateral Restraints. The design force F_A on the lateral restraints may be taken to be given by —

$$F_A = \frac{0.1 P_a}{(n+1)} K_{36} K_{37} K_{38} \dots \dots \dots (D5)$$

where P_a is the applied axial load.

D3 BEAM WITH LATERAL RESTRAINTS.

D3.1 Load Capacity. In computing the load capacity of a beam of length L with n intermediate lateral restraints as shown in Fig. D1 (b), the slenderness coefficient S_1 may be taken as —

$$S_1 = \frac{S_{max}}{(\alpha_2)^{1/6}} \dots \dots \dots (D6)$$

but not less than S_{min} and not more than S_{max} , where —

$$\alpha_2 = \frac{(n+1) K_A D L S_{max}^2}{E Z_x} K_{38} \dots \dots \dots (D7)$$

D3.2 Force on Lateral Restraints. The design force F_A , on each lateral restraint may be taken to be given by —

INTERNATIONAL COUNCIL FOR BUILDING RESEARCH STUDIES AND DOCUMENTATION

WORKING COMMISSION W18 - TIMBER STRUCTURES

METHODS OF TEST FOR THE DETERMINATION
OF MECHANICAL PROPERTIES OF PLYWOOD

by

L G BOOTH, Imperial College, London

J KUIPERS, Technische Hogeschool, Delft

B NOREN, Svenska Träforskningsinstitutet, Stockholm

C R WILSON, Council of Forest Industries, Vancouver

CIB/RILEM

Standard

Second draft: July 1976

METHODS OF TEST FOR THE DETERMINATION OF MECHANICAL PROPERTIES OF PLYWOOD

FOREWORD

(to be prepared when standard is agreed)

METHODS OF TEST

1 SCOPE

This CIB/RILEM Standard covers procedures for measuring the mechanical properties of commercial plywood containing defects permitted by the manufacturing specification. The tests described may be used to obtain characteristic strengths for design purposes, to determine the effect on strength of various natural and manufacturing defects, to ascertain properties in relation to grain or fibre direction in the material, to compare the properties of different species and for other similar purposes.

Methods are described for determining the following properties:

bending (clause 4), compression (clause 5), tension (clause 6), panel shear (clause 7), modulus of rigidity (clause 8), rolling shear (clause 9), shear in plane of plies (clause 10), moisture content (clause 11) and density (clause 12).

Any of these tests, or part of them, may be undertaken.

Tests of the glue in plywood are not included in this Standard.

Clear plywood, defined as that manufactured from veneers containing no strength reducing defects and with no manufacturing features that will influence strength (eg core gaps), may be tested in accordance with this Standard but in general it will be more economical to test it in accordance with ISO 0000.

Recommendations for the sampling of the panels from which the test specimens are cut are given in CIB 0000.

Recommendations for the evaluation of the test results are given in CIB 0000.

2 TEST SPECIMENS

2.1 Sampling of panels:

The panels from which the test specimens are cut shall be sampled in accordance with CIB 0000, or by other methods which are adequate for the purpose of the testing.

2.2 Sampling of test specimens from panels:

Specimens shall be cut from the panels in accordance with the cutting schedule given in Figure 1. Specimens for test may be selected either with the long dimension parallel to the face grain or with the long dimension perpendicular to the face grain. Alternative schedules may be developed when the specimens are cut at an angle to the grain.

3 CONDITIONING AND TESTING CLIMATES

All specimens shall normally be conditioned, prior to final machining and testing, to constant mass and moisture content in a conditioning chamber maintained at a relative humidity of 60 ± 2 per cent and at a temperature of $23 \pm 3^{\circ}\text{C}$. Constant mass is considered to be reached when two successive weighing operations, carried out at an interval of 24 hours, do not differ by more than 0.1 per cent of the mass of the test piece.

Where possible, conditions of testing should be the same as those in the conditioning chamber, but where this is not possible tests should be undertaken immediately after the specimens have been removed from the conditioning chamber.

Other climates at which testing may also be undertaken are defined in paper CIB-W18/6-11-1.

4 BENDING

4.1 Test Specimen:

4.1.1 Measurements: The method of taking measurements and the type of equipment to be used shall be in accordance with ISO/DIS 3804: Plywood - Determination of dimensions of test pieces.

The specimen thickness shall be measured to the nearest 0.02 mm at four points, two on each edge 100 mm from each end, and the average recorded. The specimen width shall be measured to the nearest 1 mm at two points 100 mm from each end, and the average recorded.

When needed for the interpretation of test results, the thickness of each ply in the test panel shall be measured to the nearest 0.02 mm.

4.1.2 Size of specimen: The test specimen shall be rectangular in cross-section. The depth of the specimen shall be equal to the thickness of the plywood and the width shall be 300 mm. The length of the specimen will depend on the method of applying the load (see clause 4.2) but shall be sufficient to ensure that the length of the zone subjected to the uniform moment shall be not less than 300 mm.

4.1.3 Sampling of test specimens from a panel: Three test specimens shall be cut from each panel in accordance with the schedule given in Figure 1. Unless otherwise specified, an estimate shall be made of the worst face of the specimen and this face shall be stressed in tension during the bending test.

4.2 Loading method and equipment:

The method of applying the load shall be such that a zone of length 300 mm shall be subjected to a uniform moment. The load may be applied as equal and opposite pure moments at the ends of the specimen, or at the third points of the span, or by other equivalent methods.

The method of applying the load shall be such that direct tension or compression forces are not applied to the specimen at large deformations.

4.3 Test procedure:

4.3.1 Rate of application of load: The load shall be applied with a continuous motion throughout the test. The rate of load application shall be such that the unit rate of fibre strain is equal to 0.000 05 mm per mm of outer fibre length per second, within a permissible variation of ± 25 per cent.

The time taken from the beginning of the loading to the maximum load shall be measured and recorded to the nearest 30 seconds.

4.3.2 Measurement of deformation: The deformation of the specimen shall be measured between two points on the longitudinal axis of the specimen located in the zone of uniform moment and spaced as far apart as possible consistent with maintaining adequate clearance between the gauges and the loading frame. The deformation data shall be measured to an accuracy of not less than 1½ per cent of the proportional limit values.

The curvature data may be obtained from measurements by either the mid-ordinate deflection method or the angular rotation at the ends of the zone of uniform moment. The mid-ordinate method uses readily available equipment and is satisfactory for most test programmes. The angular rotation method requires special instruments which are not usually available.

The mid-ordinate deflection shall be measured to the nearest 0.02 mm.

4.4 Calculations:

4.4.1 Bending stiffness and modulus of elasticity: The bending stiffness of the specimen shall be calculated from

$$EI = \frac{\Delta M}{\Delta K}$$

where EI = bending stiffness of the specimen, N.mm²
ΔM = increment of moment on the straight line portion of the moment-curvature curve, N.mm²
ΔK = increment of curvature corresponding to ΔM, mm⁻¹.

If the curvature is obtained from the mid-ordinate method

$$\frac{1}{K} = \frac{L^2}{8\delta} + \frac{\delta}{2}$$

where K = curvature, mm⁻¹
L = chord length for measuring mid-ordinate or deflection, mm
δ = mid-ordinate or deflection, mm

If a value for the bending modulus of elasticity (E) is subsequently calculated from the bending stiffness, the method of specifying the second moment of area (I) (eg full cross-sectional area, parallel plies only) must be stated.

4.4.2 Ultimate moment capacity and ultimate bending stress: The ultimate moment capacity (M) of the specimen is the maximum moment resisted by the specimen.

If a value of the ultimate bending stress is subsequently calculated from the ultimate moment capacity it shall be calculated from

$$\sigma = \frac{M}{W}$$

where σ = ultimate bending stress, N/mm²
M = maximum moment, N.mm
W = section modulus, mm³

The method of specifying the section modulus (eg full cross-sectional area, parallel plies only) shall be stated.

4.5 Moisture content and density:

After each test, samples which are to be used to measure the moisture content and density shall be cut from the specimen. The samples shall have a minimum volume of 50 000 mm³ and shall be free of visible knots, knot holes, core gaps and other voids in any ply.

The moisture content and density of each test specimen shall be determined in accordance with clauses 11 and 12.

5 COMPRESSION

5.1 Test specimen:

5.1.1 Measurements: The method of taking measurements and the type of equipment to be used shall be in accordance with ISO/DIS 3804: Plywood - Determination of dimensions of test pieces.

The specimen thickness shall be measured to the nearest 0.02 mm at four points, two on each edge 100 mm from each end, and the average recorded. The specimen width shall be measured to the nearest 1 mm at two points 100 mm from each end, and the average recorded.

When needed for the interpretation of test results, the thickness of each ply in the test panel shall be measured to the nearest 0.02 mm.

5.1.2 Size of specimen: The test specimen shall be rectangular in cross-section. Care shall be taken in preparing the test specimens to make the end surfaces smooth and parallel to each other and at right angles to the length.

The width of the specimen shall be 200 mm and its length shall be 400 mm.

In order to eliminate buckling several pieces of the plywood to be tested shall be glued face to back until the thickness of the test specimen is not less than 40 mm.

5.1.3 Sampling of test specimens from a panel: The test specimen shall be made from each panel in accordance with the schedule given in Figure 1.

5.2 Loading method and equipment:

The load shall be applied through a hinged connection on the upper head of the testing machine to allow for any deviation from parallel of the ends of the specimen, and permit adjustment to the end of the specimen in one direction. The specimen shall be loosely held by the side restraining rail. An apparatus suitable for making compression tests is shown in Figure 2.

5.3 Test procedure:

5.3.1 Rate of application of the load: The load shall be applied with a continuous motion of the movable head to maximum load at a rate of 0.000 05 mm per mm of length of the specimen per second within a permissible variation of \pm 25 per cent.

The time taken from the beginning of the loading to the maximum load shall be measured and recorded to the nearest 30 seconds.

5.3.2 Measurement of deformation: Data for load-deformation curves may be taken to determine the modulus of elasticity. The deformation shall be read to the nearest 0.002 mm. The deformation shall be taken over the central portion on both sides of the specimen using a gauge length of not less than 125 mm. The average of the two readings shall be used in the calculation of the specimen stiffness and modulus of elasticity.

5.4 Calculations

5.4.1 Compression stiffness and modulus of elasticity: The compression stiffness of the specimen shall be calculated from

$$EA = \frac{\Delta FL}{\Delta L}$$

where EA = compression stiffness of the specimen, N

ΔF = increment of load on the straight line portion of the load-deformation curve, N

L = gauge length, mm

ΔL = increment of deformation corresponding to ΔF over the gauge length L, mm

If a value for the compression modulus of elasticity (E) is subsequently calculated from the compression stiffness, the method of specifying the cross-sectional area (A) (eg full cross-sectional area, parallel plies only) shall be stated.

5.4.2 Ultimate compression capacity and ultimate compression stress: The ultimate compression capacity (F) of the specimen is the maximum compression force resisted by the specimen.

If a value of the ultimate compression stress is subsequently calculated from the ultimate compression capacity it shall be calculated from

$$\sigma = \frac{F}{A}$$

where σ = ultimate compression stress, N/mm²

F = maximum compression force, N

A = cross-sectional area, mm²

The method of specifying the cross-sectional area (A) (eg full cross-sectional area, parallel plies only) shall be stated.

5.5 Moisture content and density:

After each test, samples which are to be used to measure the moisture content and density shall be cut from the specimen. The samples shall have a minimum volume of 50 000 mm³ and shall be free of visible knots, knot holes, core gaps and other voids in any ply.

The moisture content and density of each test specimen shall be determined in accordance with clauses 11 and 12.

6 TENSION

6.1 Test specimen:

6.1.1 Measurements: The method of taking measurements and the type of equipment to be used shall be in accordance with ISO/DIS 3804: Plywood - Determination of dimensions of test pieces.

The specimen thickness shall be measured to the nearest 0.02 mm at four points, two on each edge 300 mm from each end, and the average recorded. The specimen width shall be measured to the nearest 1 mm at two points 300 mm from each end, and the average recorded.

When needed for the interpretation of test results, the thickness of each ply in the test panel shall be measured to the nearest 0.02 mm.

6.1.2 Size of specimen: The test specimen shall be rectangular in cross-section.

The width of the specimen shall be 250 mm and its length shall be 1200 mm.

6.1.3 Sampling of test specimens from a panel: Three test specimens shall be cut from each panel in accordance with the schedule given in Figure 1.

6.2 Loading method and equipment:

The specimen shall be held in grips which apply the required forces to the specimen with the minimum influence on load at, or location of, failure. Such devices shall not apply a bending moment to the test section, allow slippage under load, or inflict damage or stress concentrations to the test section. (Figure 3 illustrates the test grips.)

For ideal test conditions, the grips should be self aligning. When self-aligning grips are not available, the specimen may be clamped in the heads of a universal type testing machine with wedge-type jaws.

6.3 Test procedure

6.3.1 Rate of application of the load: The load shall be applied with a continuous motion of the movable head to the maximum load at a rate of 0.000 05 mm per mm of net length of specimen per second, within a permissible variation of ± 25 per cent. The net length of the specimen shall be taken as distance between the inside faces of the grips.

The time taken from the beginning of the loading to the maximum load shall be measured and recorded to the nearest 30 seconds.

6.3.2 Measurement of deformation: Data for load-deformation curves may be taken to determine the modulus of elasticity. The deformation shall be read to the nearest 0.002 mm. The deformation shall be taken over the central portion on both sides of the specimen using a gauge length of not less than 125 mm. The average of the readings shall be used in the calculation of the stiffness and the modulus of elasticity.

6.4 Calculations

6.4.1 Tension stiffness and modulus of elasticity: The tension stiffness of the specimen shall be calculated from:

$$EA = \frac{\Delta FL}{\Delta L}$$

where EA = tension stiffness of the specimen, N

ΔF = increment of load on the straight line portion of the load-deformation curve, N

L = gauge length, mm

ΔL = increment of deformation corresponding to ΔF over the gauge length L, mm

If a value for the tension modulus of elasticity (E) is subsequently calculated from the tension stiffness, the method of specifying the cross-sectional area (A) (eg full cross-sectional area, parallel plies only) must be stated.

6.4.2 Ultimate tension capacity and ultimate tension stress: The ultimate tension capacity (F) of the specimen is the maximum tension force resisted by the specimen.

If a value of the ultimate compression stress is subsequently calculated from the ultimate compression capacity it shall be calculated from:

$$\sigma = \frac{F}{A}$$

where σ = ultimate tension stress, N/mm²
F = maximum tension load, N
A = cross-sectional area, mm²

The method of specifying the cross-sectional area (A) (eg full cross-sectional, parallel plies only) shall be stated.

6.5 Moisture content and density:

After each test, samples which are to be used to measure the moisture content and density shall be cut from the specimen. The samples shall have a minimum volume of 50 000 mm³ and shall be free of visible knots, knot holes, core gaps and other voids in any ply.

The moisture content and density of each test specimen shall be determined in accordance with clauses 11 and 12.

7 ULTIMATE STRESS IN PANEL SHEAR

7.1 Test specimen

7.1.1 Measurements: The method of taking measurements and the type of equipment to be used shall be in accordance with ISO/DIS 3804: Plywood - Determination of dimensions of test pieces.

The specimen thickness shall be measured to the nearest 0.02 mm at four points, two on each edge 100 mm from each end and the average recorded. The specimen length shall be measured to the nearest 1 mm at two points 50 mm from each side, and the average recorded.

When needed for the interpretation of test results the thickness of each ply in the test panel shall be measured to the nearest 0.02 mm.

7.1.2 Size of specimen and method of manufacture: The dimension of the test specimen shall be as shown in Figure 4.

The plywood specimen to which the rails are glued shall be 600 mm long and not less than 430 mm wide. The distance between the rails shall be 200 mm.

The face grain of the plywood may be either parallel or perpendicular to the rails. For thin plywood it may be necessary to orientate the face grain perpendicular to the rails in order to preclude failure through buckling. Any specimen that fails in buckling shall be rejected.

Rails having minimum dimensions of 35 mm by 115 mm by approximately 700 mm long shall be glued to both sides of the plywood sample at each edge. The width of the rails may be increased to eliminate a shear failure between the rails and the plywood. The rails shall be spaced 200 mm apart with their ends even with the plywood sample at two diagonally opposite corners as shown in Figure 4.

Prior to gluing, the rails and the specimen shall be conditioned to the approximate moisture content at which the specimen is to be tested.

After gluing, a bevel of 14 deg shall be cut on the end of both pairs of rails where the major compression load is to be applied.

It is recommended that the time between gluing of rails and testing be only long enough to ensure adequate curing of the adhesive.

7.1.3 Sampling of test specimens from a panel: Three test specimens shall be cut from each panel in accordance with the schedule given in Figure 1.

7.2 Loading method and equipment:

The load shall be applied so that the resultant of the forces applied to a pair of rails shall be a single force acting along the longitudinal axis of the test specimen both in the plane of the specimen and in the thickness direction. The load on the rails shall be applied by separating the machine crossheads.

A suitable apparatus for applying equal loads to the rails is shown in Figure 5. The opposing collinear forces applied to pins located on the longitudinal axis of the specimen and perpendicular to its plane are divided into two components: (1) a major compression force applied to the end of the rail by a loading yoke free to pivot about the pin; and (2) a minor lateral force applied to the projecting end of the rail by a block that keeps the pin spaced the correct distance from the rail it loads. The major compressive load is applied through a two-way rocker and bearing plate arrangement to distribute the load uniformly to the rail end. The rigid block applying the lateral force to the projecting rail ends ensures that the pin remains perpendicular to the plane of the specimen.

7.3 Test procedure

7.3.1 Rate of application of the load: The movement of the crosshead of the testing machine shall be continuous at a rate of 0.0333 mm/s \pm 25 per cent.

The time taken from the beginning of the loading to the maximum load shall be measured and recorded to the nearest 30 seconds.

7.3.2 Acceptable test results: Any specimen that fails in buckling or in shear at the interface of the rails and the plywood shall be rejected.

7.4 Calculations

7.4.1 Ultimate panel shear stress: The ultimate panel shear stress shall be calculated from

$$\tau = \frac{F}{Lt}$$

where τ = ultimate panel shear stress, N/mm²
F = maximum load, N
L = length of shear area, mm
t = thickness of shear area, mm

7.5 Moisture content and density

After each test, samples which are to be used to measure the moisture content and density shall be cut from the specimen. The samples shall have a minimum volume of 50 000 mm³ and shall be free of visible knots, knot holes, core gaps and other voids in any ply.

The moisture content and density of each test specimen shall be determined in accordance with clauses 11 and 12.

8 MODULUS OF RIGIDITY IN PANEL SHEAR

8.1 Test specimen

8.1.1 Measurements: The method of taking measurements and the type of equipment to be used shall be in accordance with ISO/DIS 3804: Plywood - Determination of dimensions of test pieces.

The specimen thickness shall be measured to the nearest 0.02 mm at the mid-points of the four sides and the average recorded.

The length and width of the specimen shall be measured to the nearest 1 mm. When needed for the interpretation of test results the thickness of each ply in the test panel shall be measured to the nearest 0.02 mm.

8.1.2 Size of specimen: The test specimen shall be square and the length and width not less than 25 nor more than 40 times the thickness.

8.1.3 Direction of grain: The grain direction of the individual plies shall be parallel or perpendicular to the edges of the test specimen.

8.1.4 Sampling of test specimens from a panel: Specimens shall be reasonably flat. Any showing excessive initial curvature shall be rejected.

Two test specimens shall be cut from each panel in accordance with the schedule given in Figure 1.

8.2 Loading method and equipment

The test specimen shall be supported on rounded supports, having a radius of curvature not greater than 6 mm at the opposite ends of a specimen diagonal and loaded in a similar manner on the opposite ends of the other diagonal. In order that the loads may be applied at the corners, metal plates shall first be attached as shown in Figure 6. The loading and supporting frame shall be rigid.

8.3 Test procedure

8.3.1 Rate of application of the load: The load shall be applied with a continuous and uniform motion of the movable head at a rate of 0.000 05 times the length of the specimen in mm/s, within a permissible variation of ± 25 per cent.

The time taken from the beginning of the loading to the maximum load shall be measured and recorded to the nearest 30 seconds.

8.3.2 Measurements of deformation: The deformation shall be measured to the nearest 0.02 mm at two points on each diagonal equidistant from the centre of the specimen. These measurements shall be made at the quarter points of the diagonals. The specimen shall not be stressed beyond its elastic range. To eliminate the effects of any slight initial curvature, two sets of data shall be obtained, the second set with the specimen rotated 90° about an axis through the centre of the specimen and perpendicular to the plane of the plies. The two results shall be averaged to obtain the modulus of rigidity for the specimen. A satisfactory arrangement for measuring relative deformations is indicated in figures 6 and 7; the dial readings in this case give twice the average deflection of the four points.

8.4 Calculations

8.4.1 Modulus of rigidity in panel shear: The modulus of rigidity shall be calculated from:

$$G = \frac{3a^2 \Delta F}{2t^3 \Delta w}$$

where G = modulus of rigidity, N/mm^2

ΔF = increment of load applied at each corner on the straight line portion of the load - deformation curve, N

t = thickness of the specimen, mm

Δw = increment of deflection relative to the centre, mm specimen

a = distance from the centre of the specimen to the point where the deflection is measured, mm (see Figure 7).

8.5 Moisture content and density

After each test, samples which are to be used to measure the moisture content and density shall be cut from the specimen. The samples shall have a minimum volume of

50 000 mm³ and shall be free of visible knots, knot holes, core gaps and other voids in any ply. The moisture content and density of each test specimen shall be determined in accordance with clauses 11 and 12.

Where additional tests are to be made on the specimen a separate matched moisture specimen shall be provided when the specimen is cut out, in which case this moisture specimen shall be subjected to the same conditioning as the specimen itself.

9 ROLLING SHEAR

9.1 Test specimen

9.1.1 Measurements: The method of taking measurements and the type of equipment to be used shall be in accordance with ISO/DIS 3804: Plywood - Determination of dimensions of test pieces. The test specimen is shown in Figure 8.

The thickness of the two central strips and the two cover plates shall be measured to the nearest 0.02 mm at the mid-point of their areas, and the average recorded. The widths of the central strips and the cover plates shall be measured to the nearest 0.1 mm at the mid-point of the length of the smaller area of overlap (ie at section XX in Figure 8). The length of the smaller area of overlap shall be measured to the nearest 0.1 mm at the centre line of the specimen.

When needed for the interpretation of test results, the thickness of each ply in the test panel shall be measured to the nearest 0.02 mm.

9.1.2 Size of specimen and method of manufacture: The test is made on the double lap tension specimen shown in Figure 8. The specimens comprise two 50 mm wide cover plates having the face grain perpendicular to their length. The cover plates are positioned so that there is a 50 mm double lap joint at one end and a 100 mm double lap joint at the other; the gap between the ends of the central strips is 5 mm. The centre strips both have the face grain parallel to their lengths. The plywood strips are conditioned as required before assembly and the assembled specimens are again conditioned before testing.

9.1.3 Sampling of test specimens from a panel: Three test specimens shall be made from each panel. The knife checks in the face veneer of the cover plates shall be oriented so that they open during the application of the load. The face veneers of the cover plates shall contain no natural or manufacturing defects.

9.2 Loading method and equipment

The load shall be applied in tension along the length of the specimen. The specimen shall be held in grips which apply the required forces to the specimen without slipping and which do not apply a bending moment to the overlapping areas. Suitable apparatus is shown in Figure 9.

9.3 Test procedure

9.3.1 Rate of application of the load: The movement of the crosshead of the testing machine shall be continuous at a rate of 0.01 mm/s \pm 25 per cent.

The time taken from the beginning of the loading to the maximum load shall be measured and recorded to the nearest 30 seconds.

9.3.2 Acceptable test results: Any specimen which fails in a manner other than in rolling shear in the shorter lap shall be rejected.

9.4 Calculations

9.4.1 Ultimate rolling shear stress: The ultimate rolling shear stress shall be calculated from:

$$\tau = \frac{F}{2A}$$

where τ = ultimate rolling shear stress, N/mm²
F = maximum applied force, N
A = smaller area of overlap, mm²

9.5 Moisture content and density

After each test the whole of the test specimen shall be used to measure the moisture content. The moisture content shall be determined in accordance with clause 11.

The density, if required, may be found from samples matched to those from which the test specimens are made, or on samples cut after test from the longer tension tab ('A' in figure 8) clear of the area affected by the toothed grip.

10 SHEAR IN PLANE OF PLYS

10.1 Test specimen

10.1.1 Measurement: The method of taking measurements and the type of equipment to be used shall be in accordance with ISO/DIS 3804: Plywood - Determination of dimensions of test pieces.

The specimen thickness shall be measured to the nearest 0.02 mm at four points, two of each edge 100 mm from each end and the average recorded. The specimen length shall be measured to the nearest 1 mm at two points 50 mm from each side, and the average recorded.

When needed for the interpretation of test results the thickness of each ply shall be measured to the nearest 0.02 mm.

10.1.2 Size of specimen and method of manufacture: The test is made on the specimen shown in Figure 10.

The plywood specimen to which the side metal plates are glued shall be 450 mm long and 150 mm wide.

The face grain of the plywood shall be parallel to the length of the specimen. The knife edges of the loading plates shall be oriented to cause opening of the knife checks during loading in the core of a 3 ply specimen as shown in Figure 11: in the case of 5 or more ply material the knife checks in at least one of the two veneers adjacent to the face veneer shall open during loading (see Figure 11). The steel plates shall be 450 mm long, 150 mm wide and 25 mm thick. The plates shall be bonded to the plywood with an adhesive sufficiently rigid to preclude a significant contribution of adhesive creep to the measured deformation. One end of each plate shall be provided with a knife edge projecting 6 mm beyond the end of the specimen as shown in Figure 10.

10.1.3 Sampling of test specimens from a panel: Three test specimens shall be cut from panel in accordance with the schedule given in Figure 1.

10.2 Loading method and equipment

The load shall be applied through V blocks so that it is uniformly distributed along the knife edges. Pivots permitting rotation about an axis parallel to the knife edge or spherical seats free to pivot in this manner shall not be used as they create unstable loading which may cause violent ejection of the specimen from the machine and hazard to operating personnel. The V blocks shall be vertically positioned in the machine, one above the other, causing the forces applied to the specimen to act parallel to the axis of the machine. The specimen itself will be slightly inclined when placed in the machine.

10.3 Test procedure

10.3.1 Rate of application of the load: The load shall be applied continuously throughout the test at constant rate of cross-head motion determined as follows:

$$N = 0.00012 (\Sigma t_{||} + R \Sigma t_{\perp})$$

where N = crosshead speed, mm/sec

$\Sigma t_{||}$ = total thickness of plies having grain parallel to direction of shear force
mm

R = 8 (assumed ratio of shear modulus of parallel plies to shear modulus of perpendicular plies), and

Σt_{\perp} = total thickness of plies having grain perpendicular to the direction of shear force, mm

The time taken from the beginning of the loading to the maximum load shall be measured and recorded to the nearest 30 seconds.

10.3.2 Measurement of deformation: Data for load-deformation curves may be taken to determine the effective modulus of rigidity.

The slip between the steel plates shall be read to the nearest 0.002 mm. A suitable method of measuring the slip is shown in Figure 10.

10.3.3 Acceptable test results: Any specimen that fails in the bond between the metal plates and the plywood shall be rejected. Failure may occur in rolling shear, or in shear parallel to the grain, or as a combination of these failure modes with the failure plane crossing a glue line. The type of failure shall be recorded.

10.4 Calculations

10.4.1 Effective modulus of rigidity: The effective modulus of rigidity of the specimen shall be calculated from

$$G = \frac{\Delta F}{\Delta a} \frac{t}{Lb}$$

where G = effective modulus of rigidity of the specimen, N/mm²

ΔF = increment of load on the straight line portion of the load deformation curve, N

Δa = increment of slip corresponding to ΔF on the straight line portion of the load deformation curve, mm

t = thickness of specimen, mm

L = length of specimen, mm

b = width of specimen, mm

10.4.2 Ultimate shear in plane of plies stress: The ultimate shear in plane of plies stress of the specimen shall be calculated from

$$\tau = \frac{F}{Lb}$$

where τ = ultimate shear in plane of plies stress of the specimen, N/mm²

L = length of specimen, mm

b = width of specimen, mm

10.5 Moisture content and density

After each test, samples which are to be used to measure the moisture content and density shall be cut from the ply which has failed. The samples shall have sufficient volume of material to be representative of the failed ply and shall be

free of visible knots, knot holes, core gaps and other voids.

The moisture content and density of each test specimen shall be determined in accordance with clauses 11 and 12.

11 MOISTURE CONTENT

11.1 Procedure

After each test a sample which is to be used to measure the moisture content shall be cut from the body of the specimen near to the point of failure. For specimens of thin material or of small size it may be desirable to use the entire specimen as a moisture sample. Where it is not possible to use the test specimen or a part of it for moisture content measurement, a separate matched moisture specimen shall be provided when the specimen is cut out. The matched specimen shall be taken from the same portion of the board as the test specimen and shall be subjected to the same conditioning.

Reference should be made to the clauses relating to each individual test for further instruction on the size of the sample and on moisture measurement.

The moisture sample shall be weighed immediately and dried in an oven at $103 \pm 2^{\circ}\text{C}$ until approximately constant mass* is attained. After drying the sample shall be weighed immediately to an accuracy of not less than ± 0.2 per cent.

12 DENSITY

12.1 Procedure

A rectangular sample taken from the test specimen or the same portion of the board as the test specimen, shall be used to determine the density. Where suitable, the specimen which is prepared for moisture content measurement (12.1) may also be used to determine density.

Reference should be made to the clauses relating to each individual test for further instructions on the size of the sample.

The sample shall be measured and weighed to an accuracy of not less than ± 0.2 per cent.

12.2 Calculation of density

The nominal density shall be calculated from:

$$D_o = \frac{10^6 M_o}{Lbt}$$

where M_o = mass of sample, g
 L_o = length of sample, mm
 b = width of sample, mm
 t = thickness of sample, mm
 D_o = nominal density, kg/m^3

Note:

The above density is based on the volume at test and the mass when oven-dry. If the density is obtained on a different basis, then the basis of the density value with respect to volume and moisture content shall be stated.

* Constant mass is considered to be reached when two successive weighing operations, carried out at an interval of 24 hours, do not differ by more than 0.1 per cent of the mass of the test piece.

13 REPORT

The report shall include details of the test material, the method of test, and the test results. The amount of detail given under each of these headings will depend on the purpose of the tests.

The following material data shall normally be given: the species and nominal thickness of each veneer, the grain direction, the adhesive, the overall thickness, the number of veneers, the surface treatment, the manufacturing standard and the grade of the panels from which the specimens were cut.

The following data concerning the test conditions shall normally be given: the type of test, the accuracy and method of loading, the accuracy of measurements of deformation, the temperature and relative humidity at the time of test.

For individual specimens the following data shall be given: specimen dimensions, moisture content, time to failure, maximum loads, description of failure, and the calculated values of stiffness and capacity. When moduli of elasticity and ultimate stresses are calculated the basis on which they have been determined (parallel plies only, full cross-section, etc) shall be stated.

Additional data may be required in some cases. This may include the following: full details of method of manufacture, actual thickness of each veneer, full details of any natural defects or manufacturing features which influence the test results, density and load-deformation diagrams. If the test specimens are cut with their long dimension other than parallel or perpendicular to the face grain, details of the cutting schedule from the panel shall be given.

The number of specimens tested for each property shall be stated in the test report, and if a statistical treatment of the data is possible then the value of the standard deviation or coefficient of variation for each property shall also be given, as well as the mean.

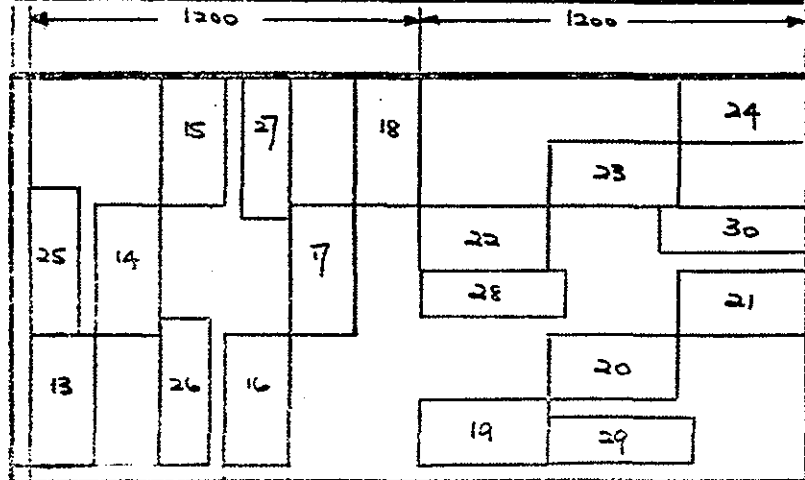
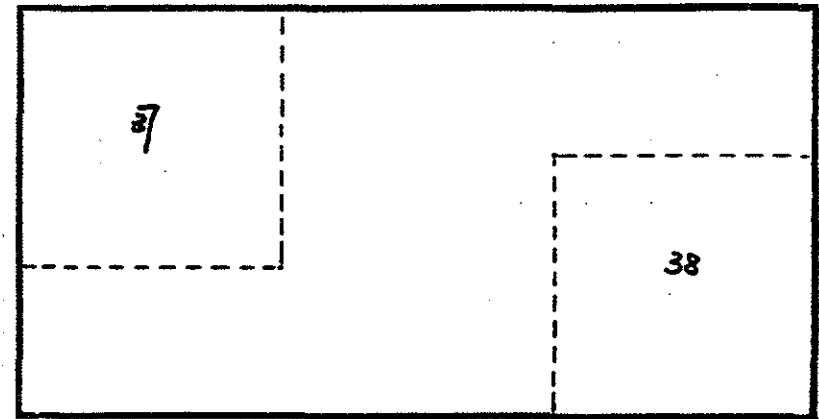
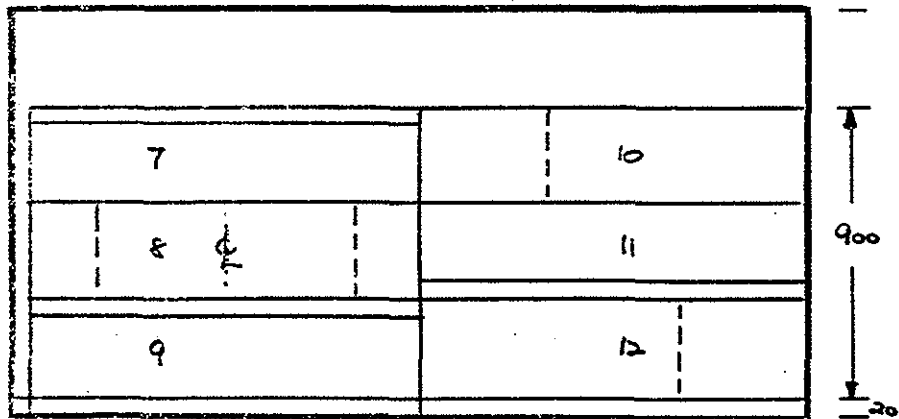
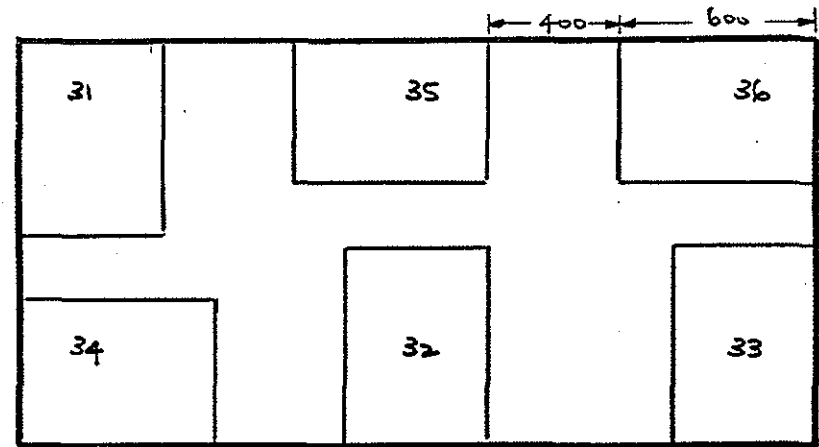
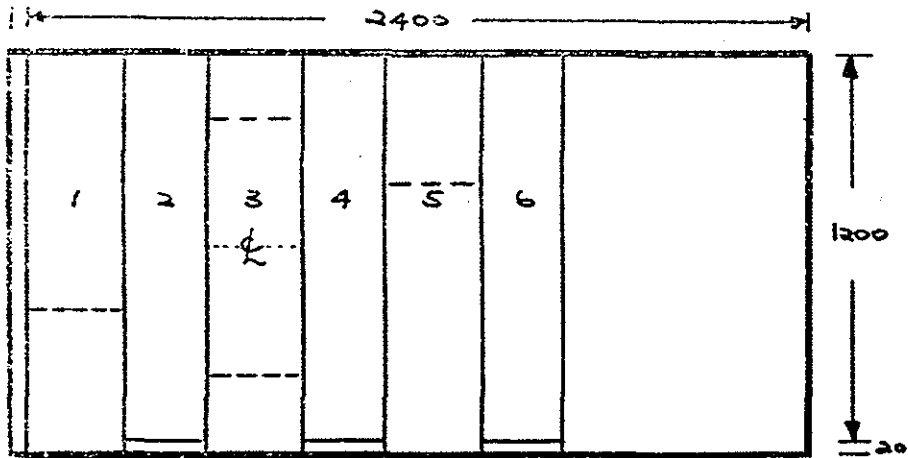

- Bending: 1, 3, 5, 8, 10, 12
- Tension: 2, 4, 6, 7, 9, 11
- Compression: (13 + 14), (19 + 20)
- Shear in plane of plies: 25, 26, 27, 28, 29, 30
- Panel shear: 31, 32, 33, 34, 35, 36
- Modulus of rigidity: 37, 38
- Rolling shear: at random from clear material

Figure 1 Cutting Schedule

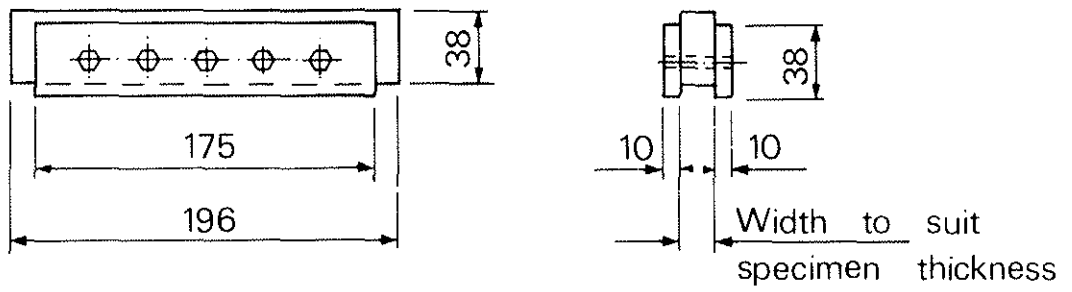

Specimen loading blocks - 2 required

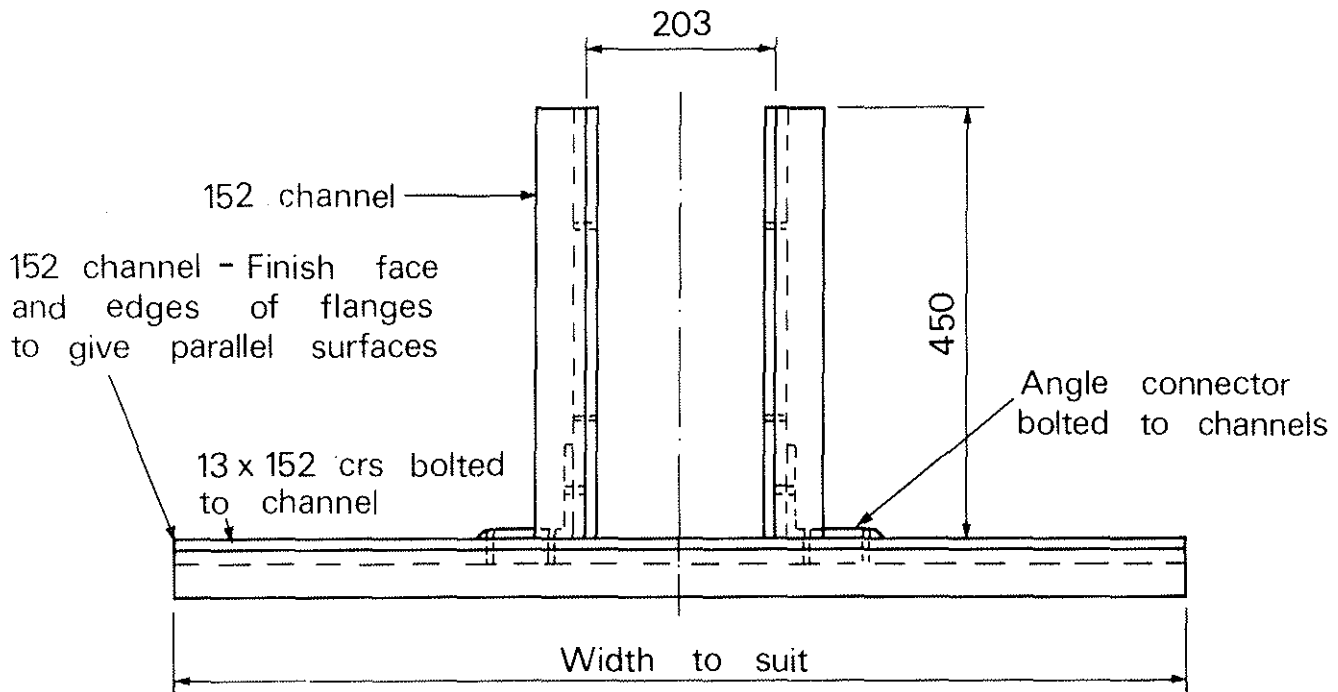
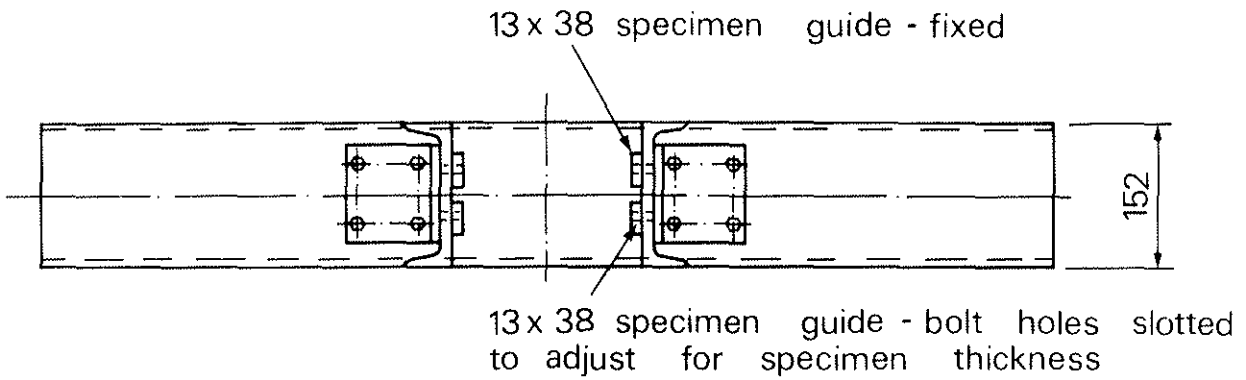

All dimensions in mm

Fig. 2. Compression test loading frame

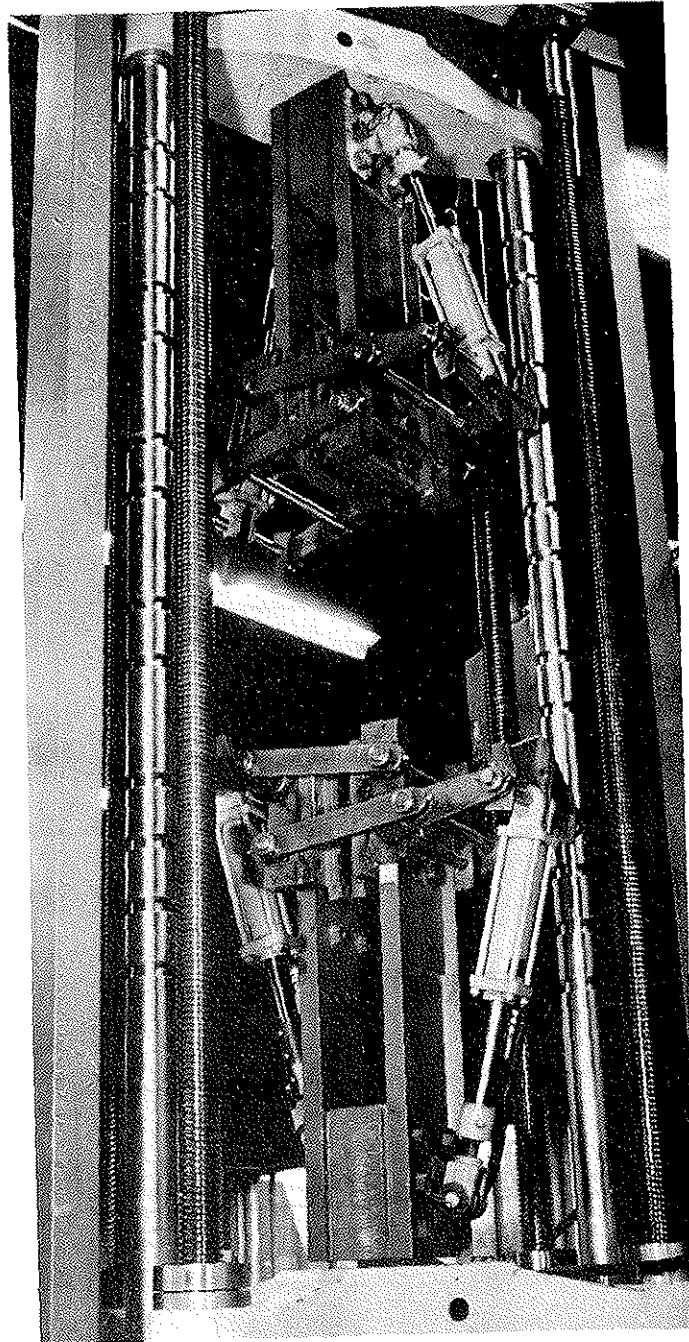

Figure 3 Grips Suitable for Tension Tests

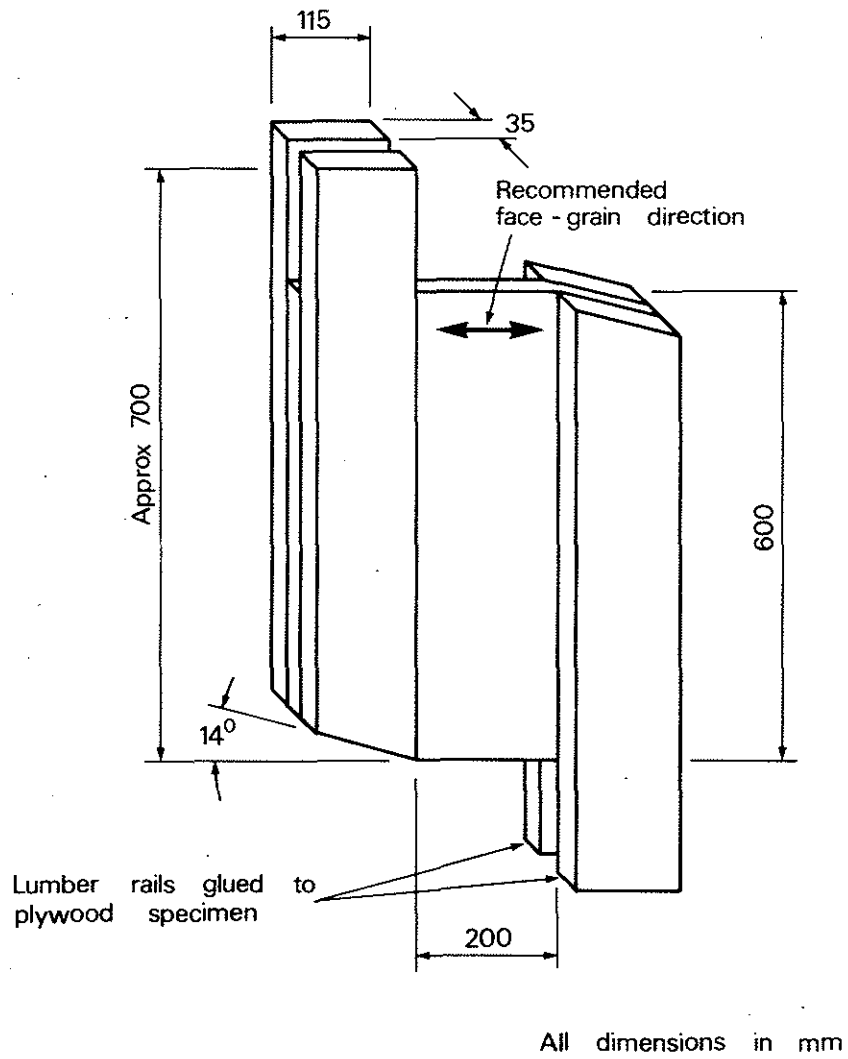

Fig. 4. Details of two - rail shear test specimen

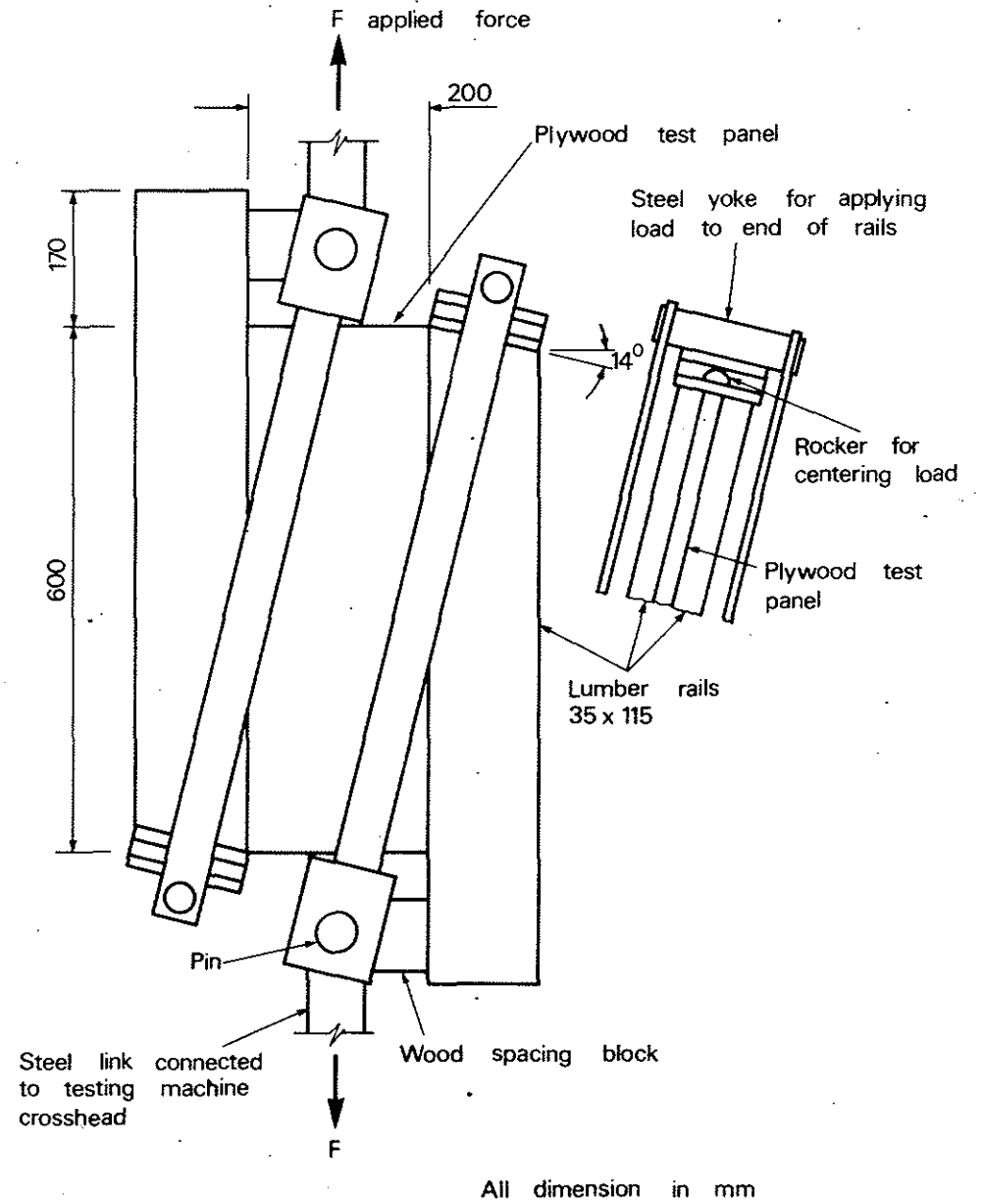
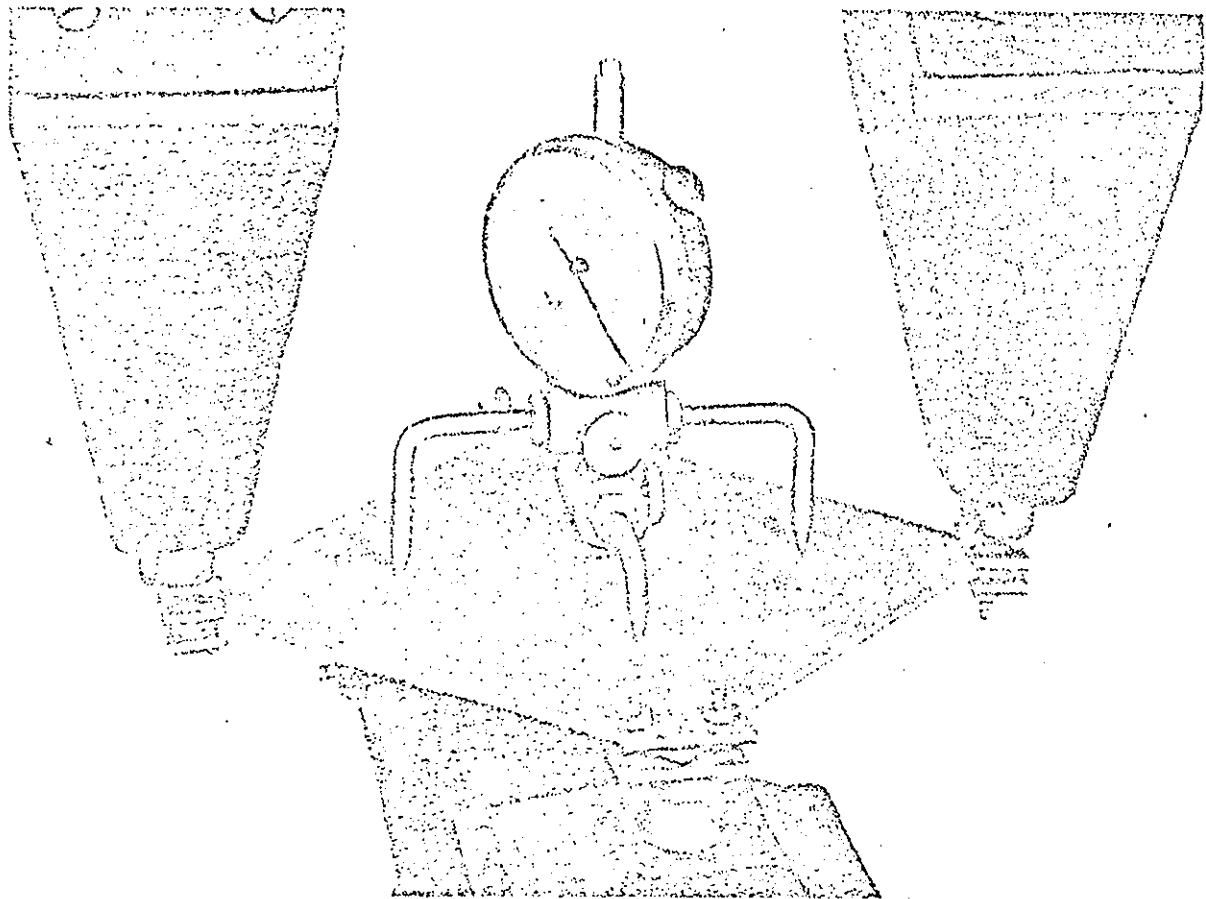

Fig. 5. Loading apparatus for two rail shear test specimen



6
Figure ~~12~~ Modulus of rigidity test of plywood showing method of loading and measuring differential deformation along the two diagonals

At the time of printing no suitable photograph was available for reproduction.

Refer to: ASTM D805; Fig 13 or British Standard 4512; Fig 9

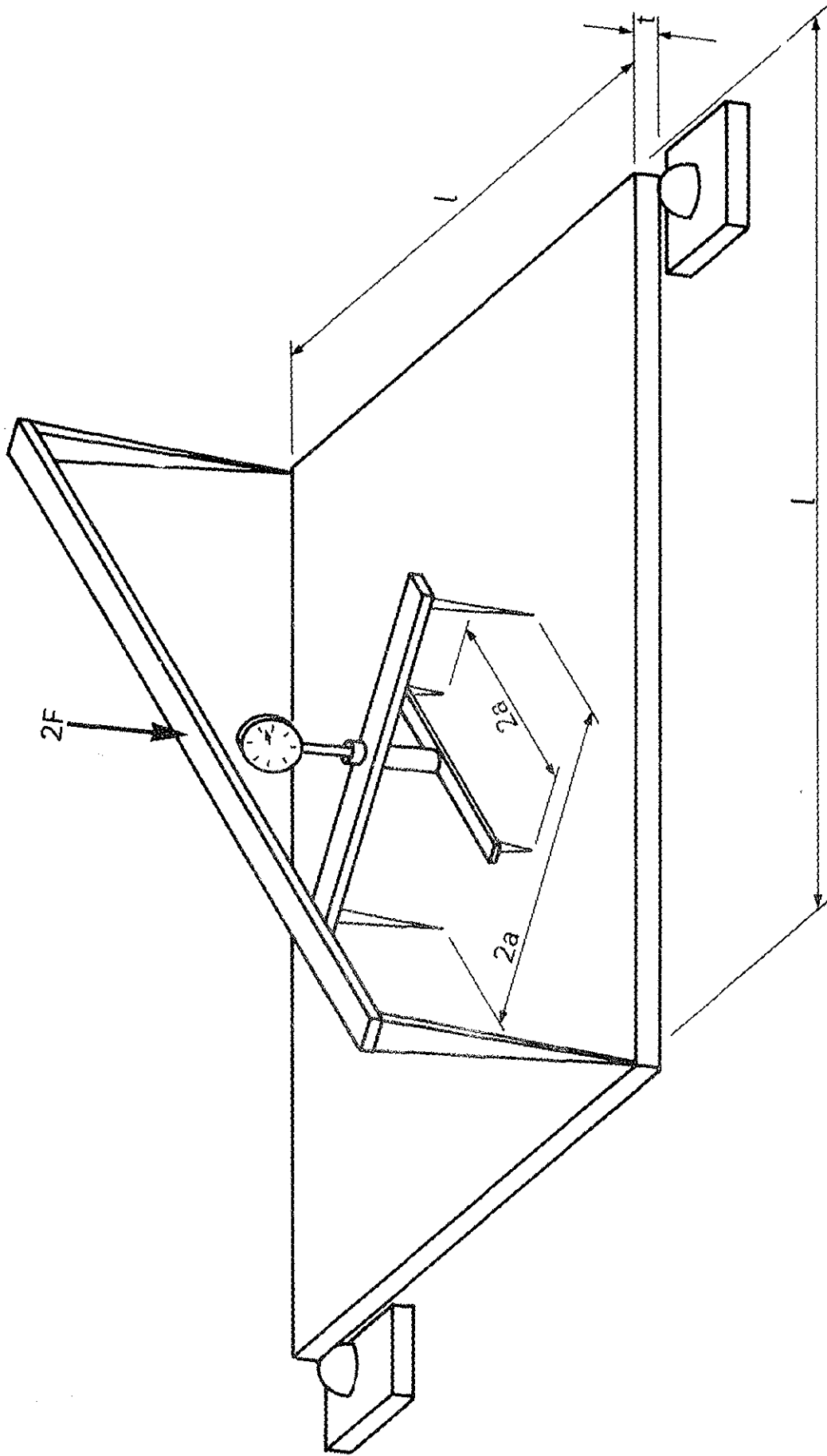
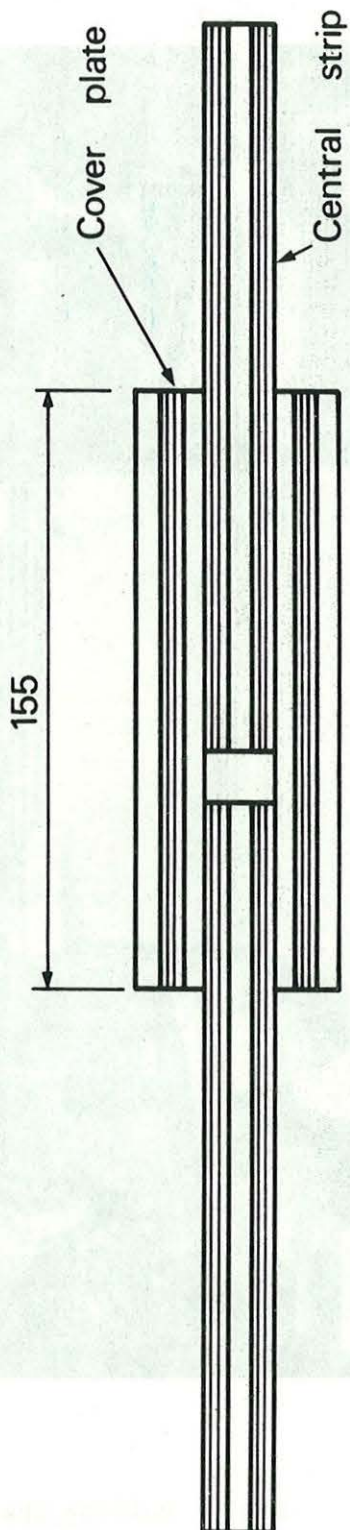
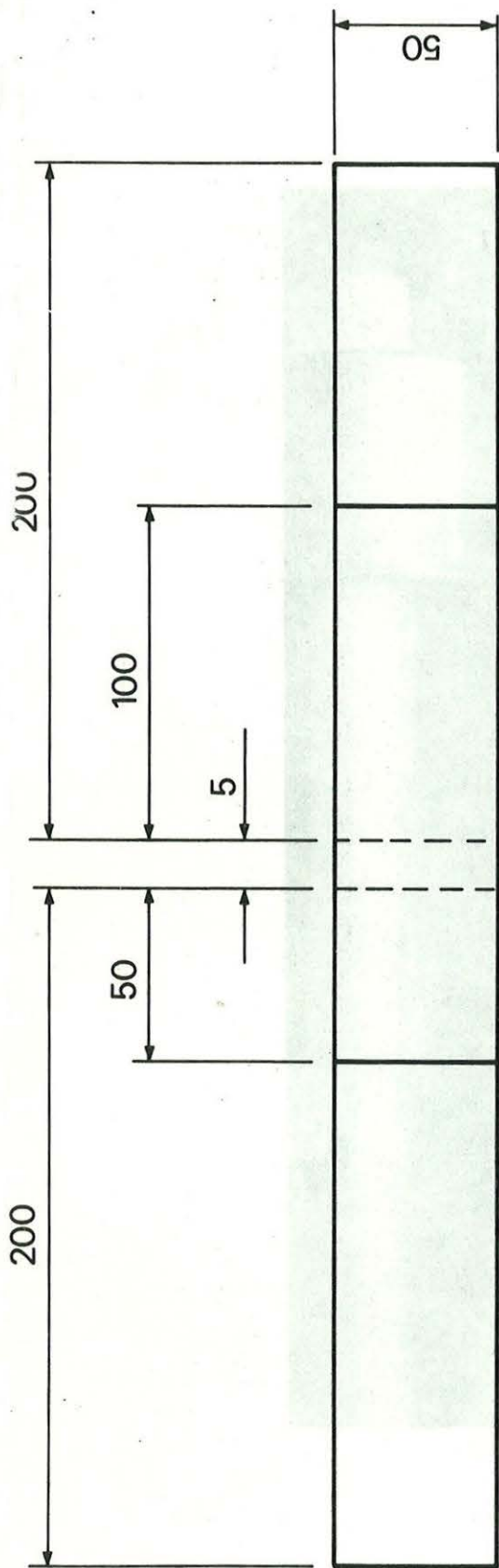



Fig. 7. Modulus of rigidity of plywood showing method of measuring deformation



-  Grain parallel to length
-  Grain perpendicular to length

All dimensions in mm

Fig. 8. Rolling shear test specimen

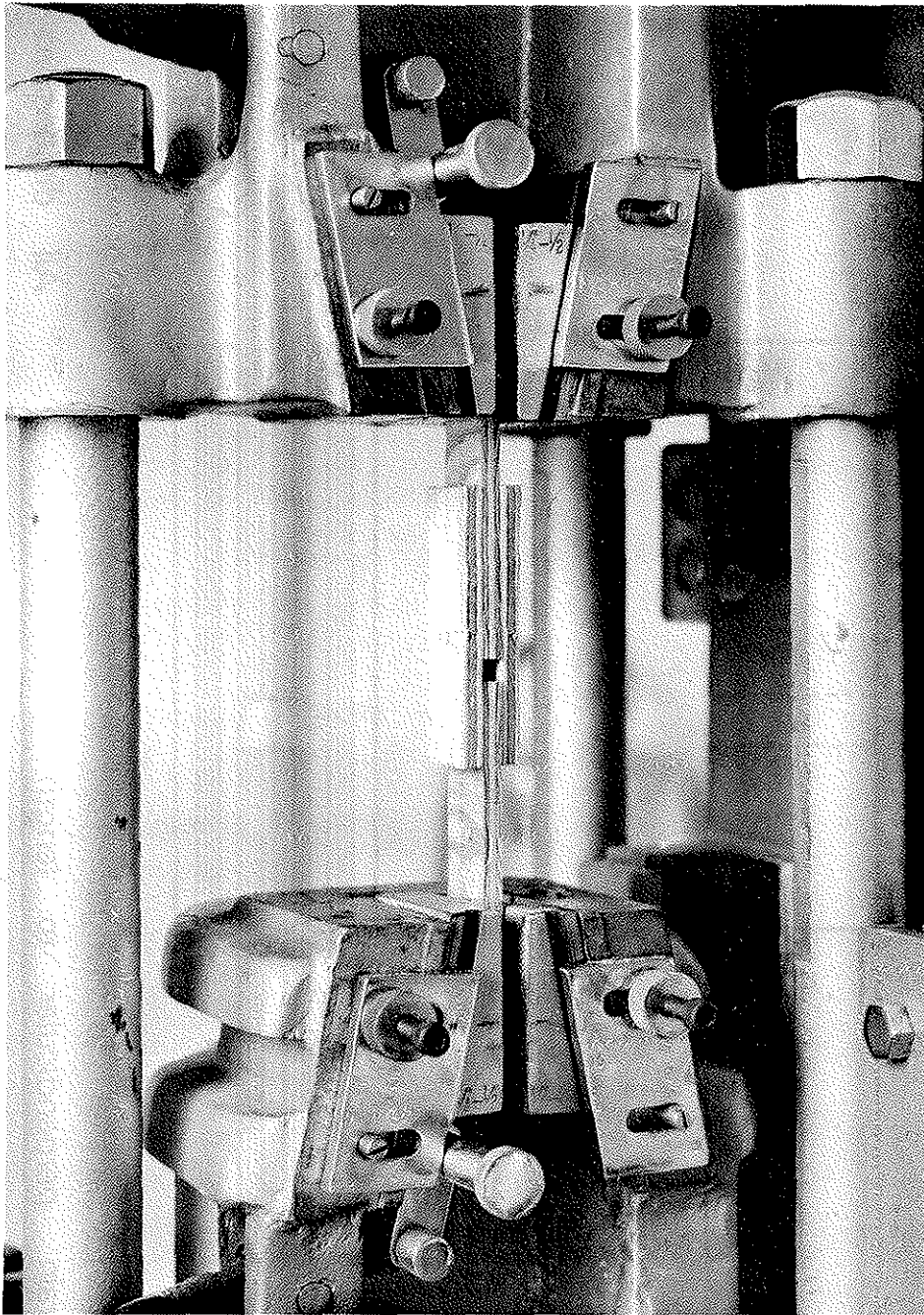
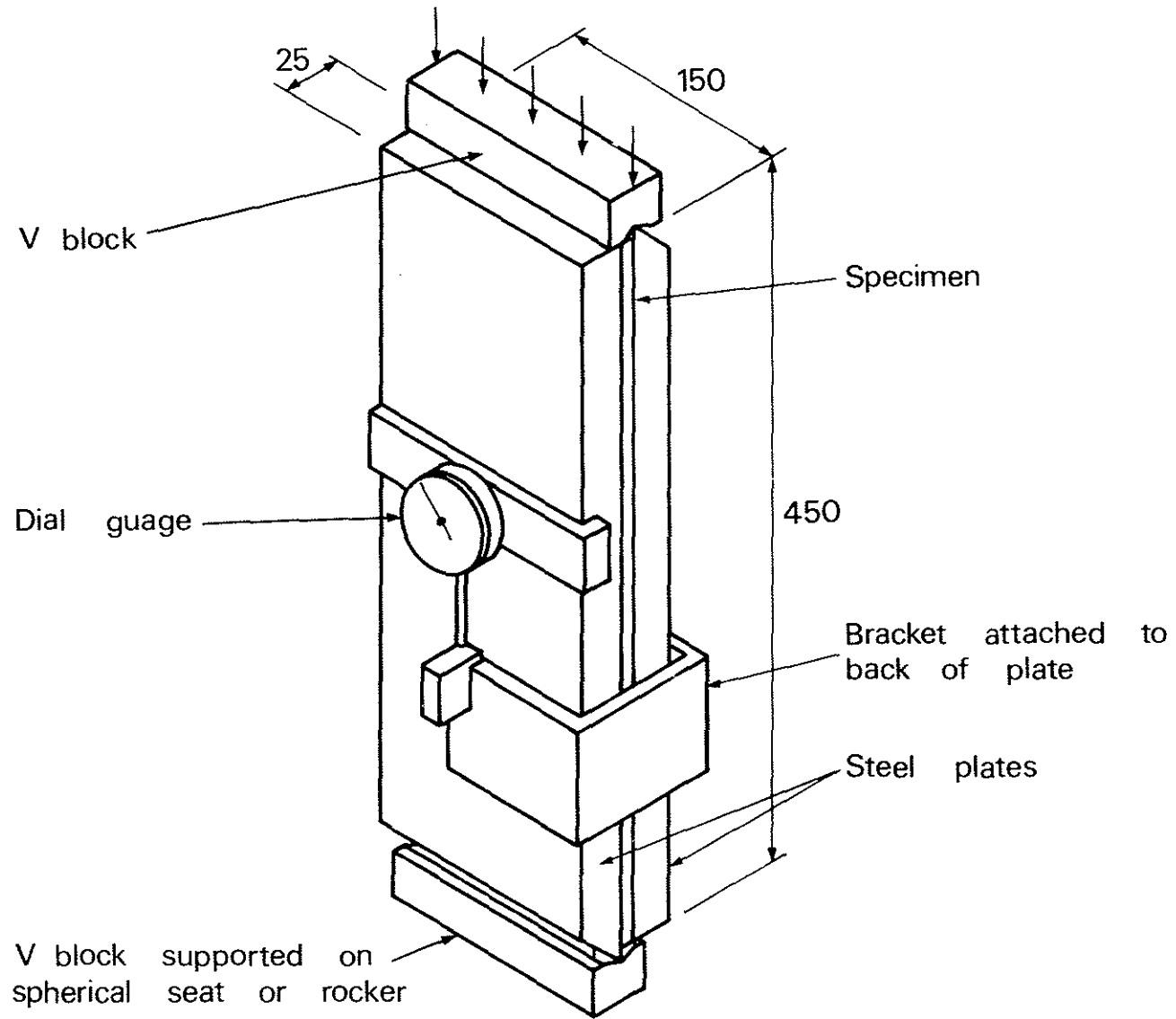

Fig 9 Rolling Shear Test



All dimension in mm

Fig. 10. Rolling shear test using a dial gauge for measuring plate slip

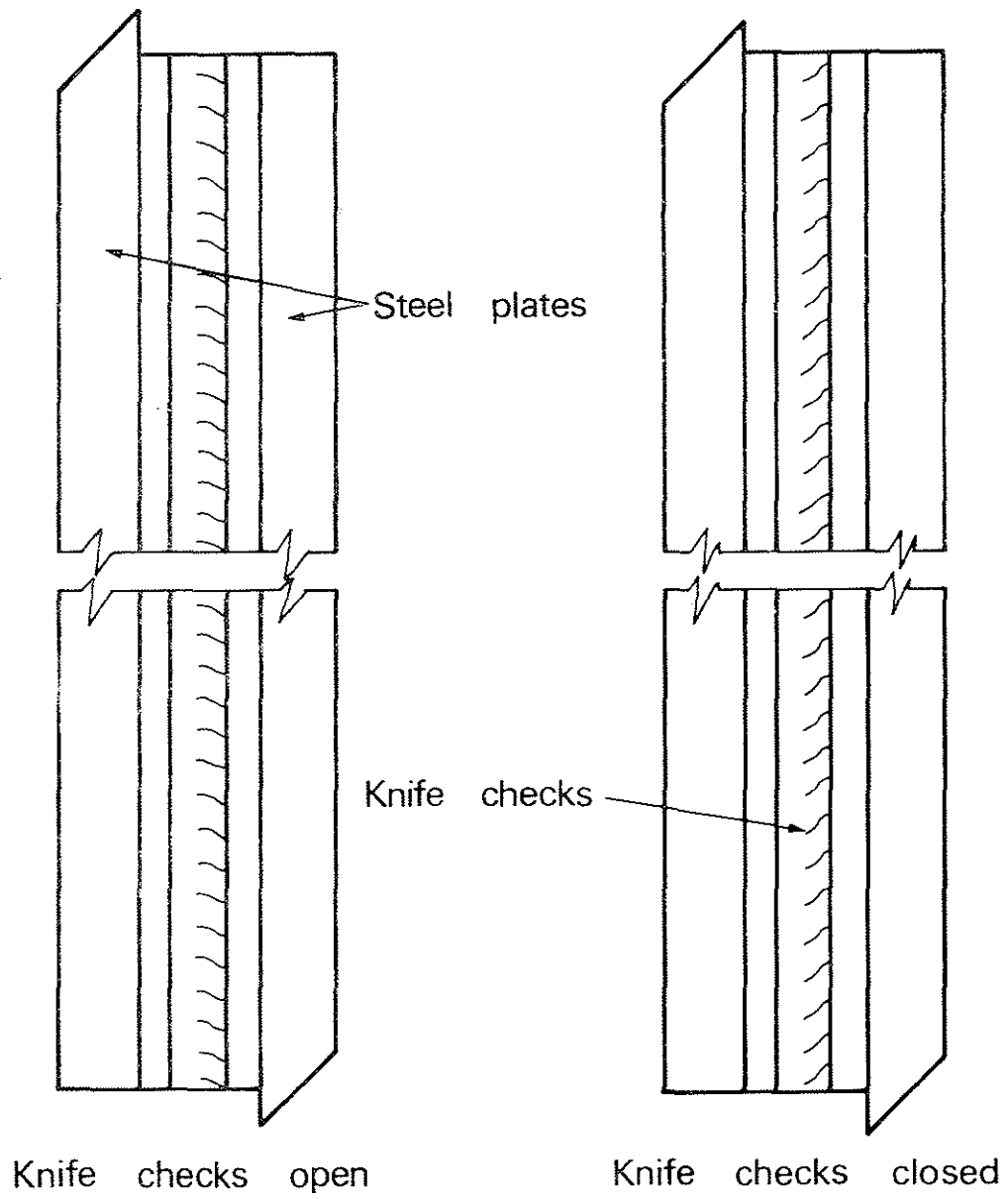

Fig. 11. Orientation of knife checks

CIB-W18/7-4-2

INTERNATIONAL COUNCIL FOR BUILDING RESEARCH STUDIES AND DOCUMENTATION
WORKING COMMISSION W18 - TIMBER STRUCTURES

COMMENTS RECEIVED ON PAPER CIB-W18/7-4-1
"METHODS OF TEST FOR THE DETERMINATION
OF MECHANICAL PROPERTIES OF PLYWOOD"

STOCKHOLM, SWEDEN - FEBRUARY/MARCH 1977

COMMENT KEY

PAVB - P A V Bryant, National Timber Research Institute, Pretoria
HK - H Kloot, CSIRO
JK - J Kuipers, Technische Hogeschool, Delft
HJL - H J Larsen, Aalborg Universitetscenter
EGS - E G Stern, Virginia Polytechnic Institute
US - U Saarelainen, Helsinki

GENERAL COMMENTS

- PAVB We have read the second draft of the proposed CIB/RILEM standard methods of test for plywood and find it quite acceptable though unfortunately we have had only very limited experience with the testing of plywood, and are therefore not really in a position to make any detailed comments.
- JK After the foreword a list with notations or symbols should be added, as well as perhaps a list of related ISO Standards. I have not checked the symbols with our list, but I wonder if we should not use the strength symbols f_c , f_t , etc.
- HJL I find that all sizes should refer to a unit width and not to the width of the test specimens. They should at least be converted to the prescribed test width (which might deviate a little from the measured width).
- EGS This second draft looks very good to me.
- 1 SCOPE
- HJL It is stated that 'Methods are described for determining the following properties'. In the following list for example modulus of rigidity is a property, but bending, compression ... is not.
- HK If, as the Scope states, the standard is to be used to study the effects of various defects and for measuring the properties of commercial plywood, then we believe it should include recommendations as to the placement of the defects being studied, or of the worst defect allowed in a particular grade. The second sentence of 4.1.3, for example, does not ensure that a knot will be placed between the load points, only that it be placed on the tension face.

2.2 Sampling of test specimens from panels:

IJK I enclose a slightly changed cutting schedule, with which it becomes possible to get information of one panel about the strength properties in both directions. It is possible to get more specimens from one panel, which in both cases is possible, but gives a bit more elegance in my proposal. No number of tests for rolling shear has been given.

	Panel		Panel	
	I	II	I	II
$\sigma_b $		8; 10; 12	8; 8 ^a	10; 12
$\sigma_b \perp$	1; 3; 5		5; 5 ^a	1; 3
$\sigma_t $		7; 9; 11	7; 9	11; 11 ^a
$\sigma_t \perp$	2; 4; 6		6; 6 ^a	2; 4

3 CONDITIONING AND TESTING CLIMATES

HJL Has the conditioning climate been stated in accordance with current or coming standards?

HK We feel the tolerance on the relative humidity is unreasonably small - ± 5 per cent, would seem more reasonable.

4 BENDING

HK On past experience, we cannot see how the bending test can become a standard procedure unless the span and the distance between the load points are expressed in terms of the plywood thickness.

4.2 Loading method and equipment:

HJL I still will not accept that the Canadian test machine gives pure bending at the ends. In all cases there is 4-point loading where the two middle loads may be placed in the third-points or near the outer loads.

US My comments merely concern the spans in bending test.

If the length of the uniform moment is to 300 mm, you should state in 4.2: 'The load must be applied as equal and opposite pure moments'. If, similarly third point loading is used, the deflections will be so large, that the contact line at the rollers will be significantly moved from the centre-lines of rollers, and, on the other hand, the direction and the magnitude of the acting forces are increased (Fig 2). The former feature decreases the moment arm, the latter increases the acting forces.

These combined, the actual moments may deviate from the calculated moment (product of applied force and distance between support and loading head) by much more than 1.5 per cent.

Only when the plywood thickness is about 30 mm (which happens to correspond to the commonly used span-to-depth-ratio of 30), the error becomes negligible. On the other hand, if you use the expansion $L^2/8\delta$ for the radius of curvature instead of $(L^2/8\delta) + (S/2)$, the error can be formulated as $\text{err}(1/k) = 1/(1 + L^2/(2\delta)^2)$, ($L = 250$ mm) which reaches a value of 0.015 when δ is more than 15.4 mm ($L = 250$ mm).

Up to that value (ref Fig 1) you will find larger errors in your estimate for moment, whatever your roller diameter. You can, of course, avoid a large amount of the errors in moment by allowing the span-to-depth ratio at 3rd point loading to stay between 20 and 40.

4.4.1

HJL N.mm^2 should also here be written as Nmm. ΔM is in Nmm.

4.4.2

HJL Nmm instead of N.mm!

HK We heartily endorse the requirement that the section modulus be specified as based on full cross-sectional area and/or parallel plies only.

5 COMPRESSION

5.1.2 Size of specimen:

JK The size of the test specimen for compression seems rather large to me. We have chosen a smaller specimen which has in addition the ratios of h, b and d comparable with normal wood specimens. This specimen with $b \approx d$ and $h = 3b$ needs no side restraining (dimensions 150 x 150 x (≈ 50) mm).

5.2 Loading method and equipment

HJL I do not understand the test set-up. In Figure 2 there is a distance of $17\frac{3}{4}$ inches (~ 450 mm), but the specimen length is only 400 mm^2 . Besides, side restraint should be superfluous, otherwise the slenderness ratio of the specimen should be reduced.

5.3.2 and 6.3.2

HJL It is impossible to measure a deformation of 0.002 mm.

6 TENSION

6.1.2 Size of specimen:

HK Having done quite a few tension tests on plywood specimens, 250 mm or more in width, we cannot see how tests are going to be effective on purely rectangular specimens. Either the specimen has to be shaped or the ends must be built up to ensure that failure takes place in the body of the specimen and not at or close to the grips.

6.2 Loading method and equipment:

JK The tension test specimen as proposed has no profile along the length; is the risk of failure in or near the grips of the testing machine not too great? Is it allowed to glue blocks to the plywood specimen to reach in certain cases a sufficient thickness for the grips? Why are only wedge-type jaws allowed; is this restriction necessary? We use grips which are pressed together with oil cylinders.

7 ULTIMATE STRESS IN PANEL SHEAR

7.1.2 Size of specimen and method of manufacture

JK Why is it recommended that the time between gluing of rails and testing be 'only' long enough to?

HJL If the width of the railings is increased the values given in Figure 4 (eg the 14°) are no longer valid.

7.2 Loading method and equipment:

HK We would question whether the rail shear specimen loaded as in Fig 5 would give any more meaningful results than a specimen as shown in Fig 4 with the opposite ends of the rails cut at the appropriate angle, and the specimen loaded in simple compression.

8 MODULUS OF RIGIDITY IN PANEL SHEAR

JL Does this method really give Modulus of Rigidity in Panel Shear? In my opinion it gives torsional rigidity.

8.3.2 Measurements of deformation:

JK Proposal: 'the dial readings in this case give twice the increment of deflection relative to the centre (so $2 \Delta w$, compare 8.4.1)'.

9 ROLLING SHEAR

JK Even after our discussions at Blockhus I am not sure if there is a difference between 'rolling shear' and 'shear in plane of plies'. I understand that the latter method gives the possibility of measuring a G-value, but as I expect that there will be differences of τ according to both test methods I should prefer only one method.

This then should be the one given in Fig 10 and 11. In Fig 10 and for 11 the action line of the loads could be given. In Fig 11 it should be added that case (a) has to be tested.

HK We would also question the difference between '9 Rolling Shear' and '10 Shear in the Plane of Plies'. Certainly the test for '9' involves a stress concentration which however may not be critical in this ply configuration.

9.1.2 Size of specimen and method of manufacture:

JK Has anything to be said about the type of glue used to manufacture the specimen? Should a remark be made that the gap between the central strips may not be filled with glue?

11 MOISTURE CONTENT

EGS The only question I have is that of the minimum volume of the samples required for the determination of moisture content and density. We are using the mercury volumometer and prefer to use several small specimens instead of one large specimen. The use of several small specimens has the advantage that they can be taken from different locations of the plywood; hence, are more representative.

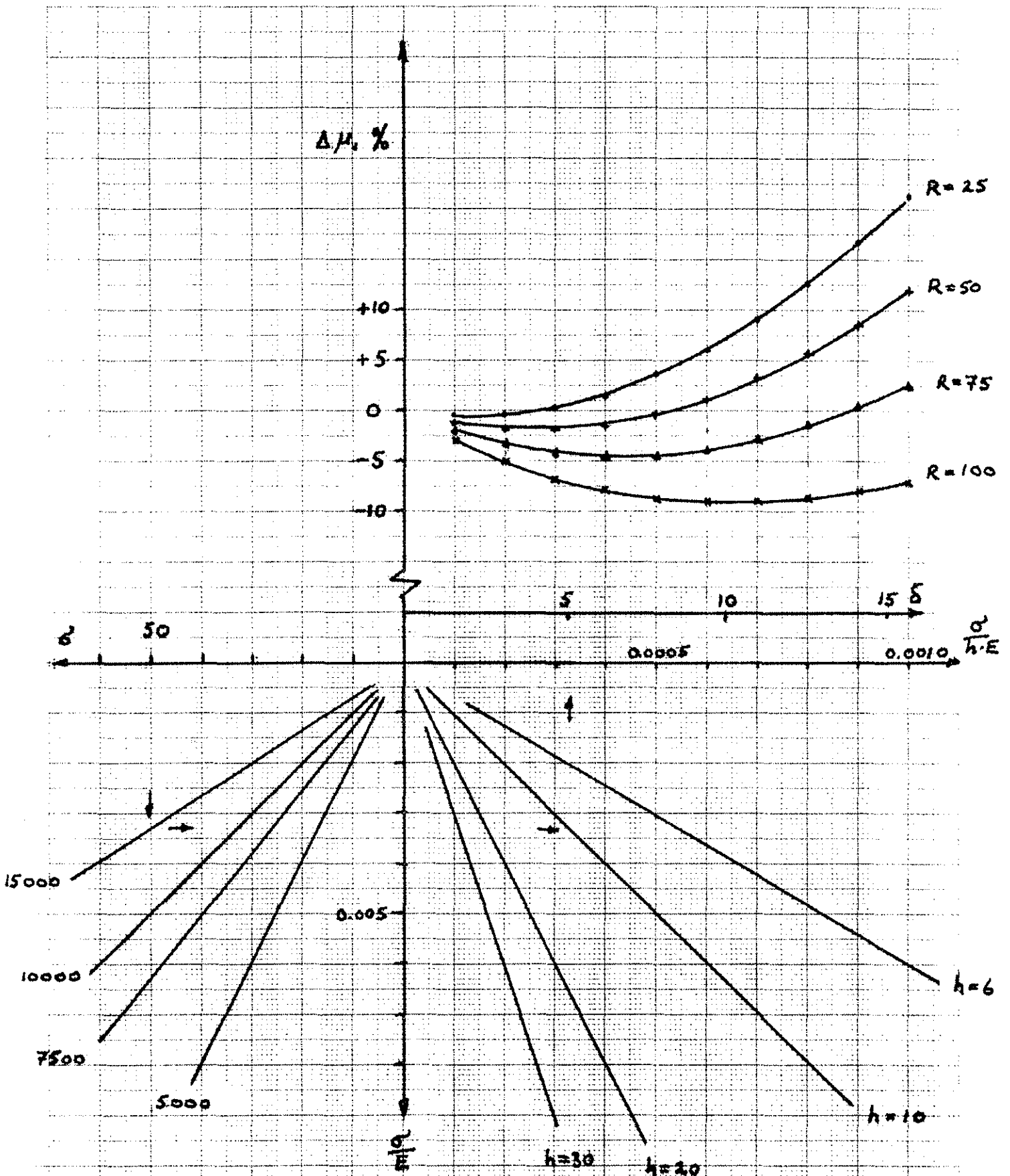
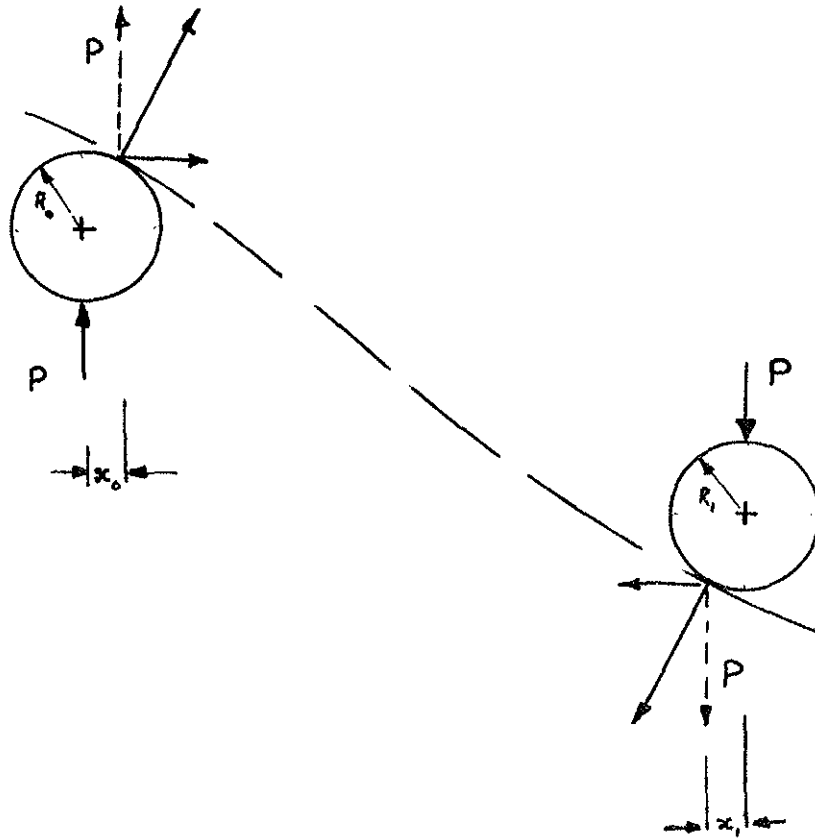

Fig 1: The Relative Error, $100 \left(\frac{M}{P_a} - 1 \right)$, as a function of σ, E, h and R . (R = radius of support rollers)

Units : N, mm



$$\mu = P(a - x_0 - x_1) + P \cdot \frac{x_0}{\sqrt{R_0^2 - x_0^2}} \left(\Delta y - R_0 - R_1 + \frac{x_0}{\sqrt{R_0^2 - x_0^2}} + \frac{x_1}{\sqrt{R_1^2 - x_1^2}} \right)$$

Fig 2 :

APPENDIX 1

COMMENTS FROM Dr C R WILSON - COUNCIL OF FOREST INDUSTRIES

Comments dealing with matters of principle are given first. These are followed by comments of an editorial nature.

Rate of Load Application

Rate of load application is based on rate of fibre strain and is the same for all tests. This differs from the ASTM philosophy where the time to failure (3 - 10 minutes) is used for the basis on which to determine rate of load application. Because of the way in which plywood reacts to different loads, the ASTM rates differ from the proposed rate for the different tests.

Current experimental data on time effect is rather limited. We are currently examining this effect and hope to have additional information available.

4. Bending Test

As the bending properties are perhaps the most important and as the panel is almost always used in its full width, we believe that it is a realistic requirement that the bending test uses a full width panel or something approaching the full width. Recognizing the concern for using generally available commercial equipment, we agree that the standard should at least provide for an option to the full width panel. Hence, we are currently working on a proposal.

7. Panel Shear Test

We recommend that the determination for modulus of rigidity using this test should be provided for as an option.

8. Modulus of Rigidity in Panel Shear Test

It would appear that the mode of distortion in the modulus of rigidity in panel shear test - particularly in plywood containing core gaps - would be better measured in the panel shear test. Hence, it is suggested that some experimental work be done prior to acceptance of the plate shear type of test.

9. Rolling Shear Test

It is recognized that this test was introduced to provide basic strength data for use in the design of web beams, stressed skin panels, etc. Recent extensive tests by COFI and WFPL have determined that knots and the relatively larger areas of grain distortion around the knots significantly affect the rolling shear stress (and the modulus of rigidity) and that the grain characteristics are dependant on the species. As a result of this phenomenon, species having relatively higher flexural strength and modulus of elasticity may have relatively lower rolling shear strength (and modulus of rigidity) or vice versa.

Due to the fact that in plywood/lumber structural assemblies rolling shear forces are induced over a relatively large "strip" (where an "averaging" effect can take place) and in light of the above we suggest that the use of the proposed test would result in basic strength data that does not represent the true strength of the plywood. Hence, we recommend that this test procedure be deleted from the proposed standard.

10. Shear in Plane of Plies Test

In this test the type and size of specimen is such that knots and the areas of grain distortion around the knot are accommodated. However, basing the basic property on only open lathe checks is questionable.

In most practical applications shear in plane of plies stresses are induced in the plywood when the plywood plate is supported at two or more points and loaded by either a concentrated or uniform load. For such cases the direction of shear in plane of plies stresses will have the "reverse" direction at the point of maximum moment. Consequently, the cross bands will be stressed in such a way that the lathe checks will open in one portion and close in the other portion of the span. Without going into a detailed analysis, it can be shown by examining two failure bounds (constant shear rotation and constant shear stress) that failure in the cross band will occur at a level somewhere between the open and closed lathe check shear capacity. Therefore, it is recommended that the design stress be based on testing one-half the specimens open and one-half the specimens closed. Such a procedure would result in a relatively high coefficient of variation and in turn would result in a conservative 5 percent exclusion value.

EDITORIAL COMMENTS FROM Dr C R WILLSON (COFI)

The relevant parts of the standard are reproduced followed by the suggested amendment.

1 SCOPE

This CIB/RILEM Standard covers procedures for measuring the mechanical properties of commercial plywood containing defects permitted by the manufacturing specification. The tests described may be used to obtain characteristic strengths for design purposes, to determine the effect on strength of various natural and manufacturing defects, to ascertain properties in relation to grain or fibre direction in the material, to compare the properties of different species and for other similar purposes.

LAYUPS

~~Any of these tests, or part of them, may be undertaken.~~

DELETE

Clear plywood, defined as that manufactured from veneers containing no strength reducing defects and with no manufacturing features that will influence strength (eg core gaps), may be tested in accordance with this Standard but in general it will be more economical to test it in accordance with ISO 0000.

DEFECTS

~~Recommendations for the sampling of the panels from which the test specimens are cut are given in CIB 0000.~~

DELETE

2.1 Sampling of panels:

The panels from which the test specimens are cut shall be sampled in accordance with CIB 0000, or by other methods which ~~are~~ adequate for the purpose of the testing.

ANY

IS

2.2 Sampling of test specimens from panels:

Specimens shall be cut from the panels in accordance with the cutting schedule given in Figure 1. Specimens for test may be selected either with the long dimension parallel to the face grain or with the long dimension perpendicular to the face grain. Alternative schedules may be developed when the specimens are cut at an angle to the grain.

DEPENDING ON THE GRAIN ORIENTATION WHICH IS TO BE TESTED

3 CONDITIONING AND TESTING CLIMATES

All specimens shall normally be conditioned, prior to final machining and testing, to constant mass and moisture content in a conditioning chamber maintained at a relative humidity of 60 ± 2 per cent and at a temperature of $23 \pm 3^\circ\text{C}$. Constant mass is considered to be reached when two successive weighing operations, carried out at an interval of 24 hours, do not differ by more than ~~0.1~~ per cent of the mass of the test piece.

0.2

EQUILIBRIUM

AND THEREFORE EQUILIBRIUM MOISTURE CONTENT

4 BENDING

(BENDING STIFFNESS, MODULUS OF ELASTICITY, ULTIMATE MOMENT CAPACITY, ULTIMATE BENDING STRESS)

4.1 Test Specimen:

4.1.1 Measurements: The method of taking measurements and the type of equipment to be used shall be in accordance with ISO/DIS 3804: Plywood - Determination of dimensions of test pieces.

4.1.3

The specimen thickness shall be measured to the nearest 0.02 mm at four points, two on each edge 100 mm from each end, and the average recorded. The specimen width shall be measured to the nearest 1 mm at two points 100 mm from each end, and the average recorded.

OF THE ZONE OF THE SPECIMEN EXPOSED TO
MAXIMUM MOMENT

When needed for the interpretation of test results, the thickness of each ply in the test panel shall be measured to the nearest 0.02 mm. AT THE SAME

LOCATION WHERE THE SPECIMEN THICKNESS MEASUREMENTS ARE MEASURED, AND THE AVERAGE THICKNESS OF EACH PLY RECORDED.

4.1.3 Sampling of test specimens from a panel: Three test specimens shall be cut from each panel in accordance with the schedule given in Figure 1. Unless otherwise specified, an estimate shall be made of the worst face of the specimen and this face shall be stressed in tension during the bending test.

4.1.1

(SIMILAR REORDERING OF CLAUSES ON "MEASUREMENTS" AND "SAMPLING" TO BE MADE THROUGHOUT THE STANDARD)

4.2 Loading method and equipment:

The method of applying the load shall be such that a zone of length 300 mm shall be subjected to a uniform moment. The load may be applied as equal and opposite pure moments at the ends of the specimen, or at the third points of the span, or by other equivalent methods.

ANY

EQUAL CONCENTRATED LOADS

4.3.2 Measurement of deformation: The deformation of the specimen shall be measured between two points on the longitudinal axis of the specimen located in the zone of uniform moment and spaced as far apart as possible consistent with maintaining adequate clearance between the gauges and the loading frame. The deformation data shall be measured to an accuracy of not less than 1 1/2 per cent of the proportional limit values.

~~The curvature data may be obtained from measurements by either the mid-ordinate deflection method or the angular rotation at the ends of the zone of uniform moment. The mid-ordinate method uses readily available equipment and is satisfactory for most test programmes. The angular rotation method requires special instruments which are not usually available.~~

DELETE

MIDWAY

THE TWO POINTS SHALL BE

5 COMPRESSION

(COMPRESSION STIFFNESS, MODULUS OF ELASTICITY, ULTIMATE COMPRESSION CAPACITY, ULTIMATE COMPRESSION STRESS)

5.1.3 Sampling of test specimens from a panel: The test specimen shall be made from each panel in accordance with the schedule given in Figure 1.

FOR THE GRAIN ORIENTATION BEING TESTED

ONE

6 TENSION

(TENSION STIFFNESS, STRESS)

6.1 Test specimen:

6.1.1 Measurements:

When needed for the interpretation of test results, the thickness of each ply in the test panel shall be measured to the nearest 0.02 mm.

ADD AS 4.1.1

6.1.3 Sampling of test specimens from a panel: Three test specimens shall be cut from each panel in accordance with the schedule given in Figure 1.

FOR EACH GRAIN ORIENTATION BEING TESTED

6.2 Loading method and equipment:

The specimen shall be held in grips which apply the required forces to the specimen with the minimum influence on load at, or location of, failure. Such devices shall not apply a bending moment to the test section, allow slippage under load, or inflict damage or stress concentrations to the test section. (Figure 3 illustrates the test grips.)

SUITABLE

7 ~~ULTIMATE STRESS IN PANEL SHEAR~~

(ULTIMATE PANEL SHEAR STRESS)

7.1.2 Size of specimen and method of manufacture: The dimension of the test specimen shall be as shown in Figure 4.

The plywood specimen to which the rails are glued shall be 600 mm long and not less than 430 mm wide. The distance between the rails shall be 200 mm.

The face grain of the plywood may be either parallel or perpendicular to the rails. For thin plywood it may be necessary to orientate the face grain perpendicular to the rails in order to preclude failure through buckling. Any specimen that fails in buckling shall be rejected.

LUMBER

Rails having minimum dimensions of 35 mm by 115 mm by approximately 700 mm long shall be glued to both sides of the plywood sample at each edge. The width of the rails may be increased to eliminate a shear failure between the rails and the plywood. The rails shall be spaced 200 mm apart with their ends even with the plywood sample at two diagonally opposite corners as shown in Figure 4. STEEL

RAILS MAY BE USED IN LIEU OF LUMBER RAILS.

Prior to gluing, the ^{LUMBER} rails and the specimen shall be conditioned to the approximate moisture content at which the specimen is to be tested.

After gluing, a bevel of 14 deg shall be cut on the end of both pairs of ^{LUMBER} rails where the major compression load is to be applied.

It is recommended that the time between gluing of ^{LUMBER} rails and testing be only long enough to ensure adequate curing of the adhesive.

7.1.3 Sampling of test specimens from a panel: Three test specimens shall be cut from each panel ^L in accordance with the schedule given in Figure 1.

FOR THE GRAIN ORIENTATION BEING TESTED

7.3.2 Acceptable test results: ~~Any specimen that fails in buckling or in shear at the interface of the rails and the plywood shall be rejected.~~

ONLY SPECIMENS THAT FAIL IN SHEAR BETWEEN THE RAILS SHALL BE ACCEPTED

10 SHEAR IN PLANE OF PLIES

(EFFECTIVE MODULUS OF ELASTICITY, ULTIMATE SHEAR IN PLANE OF PLIES STRESS)

10.1 Test specimen

10.1.1 Measurement:

When needed for the interpretation of test results the thickness of each ply shall be measured to the nearest 0.02 mm.

ADD AS 4.1.1

10.1.2 Size of specimen and method of manufacture: The test is made on the specimen shown in Figure 10.

The face grain of the plywood shall be parallel to the length of the specimen. The knife edges of the loading plates shall be oriented to cause opening of the knife checks during loading in the core of a 3 ply specimen as shown in Figure 11: in the case of 5 or more ply material the knife checks in at least one of the two veneers adjacent to the ~~face veneer~~ shall open during loading (see Figure 11). The steel plates shall be 450 mm long, 150 mm wide and 25 mm thick. The plates shall be bonded to the plywood with an adhesive sufficiently rigid to preclude a significant contribution of adhesive creep to the measured deformation. One end of each plate shall be provided with a knife edge projecting 6 mm beyond the end of the specimen as shown in Figure 10.

OUTER PLY

12 DENSITY

* Constant mass is considered to be reached when two successive weighing operations, carried out at an interval of 24 hours, do not differ by more than ~~0.1~~ per cent of the mass of the test piece.

0.2

13 REPORT

The following data concerning the test conditions shall normally be given: the type of test, the accuracy and method of loading, the accuracy of measurements of deformation, the temperature and relative humidity at the time of test.

WITHIN THE CONDITIONING CABINET

The number of specimens tested for each property shall be stated in the test report, and if a statistical treatment of the data is possible then the value of the standard deviation or coefficient of variation for each property shall also be given, as well as the mean.

AND PANELS

- Bending: 1, 3, 5, 8, 10, 12
- Tension: 2, 4, 6, 7, 9, 11
- Compression: (13 + 14), (19 + 20)
- Shear in plane of plies: ~~25, 26, 27~~, 28, 29, 30
- Panel shear: 31, 32, 33, 34, 35, 36
- Modulus of rigidity: 37, 38
- Rolling shear: at random from clear material

DELETE

Figure 1 Cutting Schedule

CIB-W18/7-4-3

INTERNATIONAL COUNCIL FOR BUILDING RESEARCH STUDIES AND DOCUMENTATION
WORKING COMMISSION W18 - TIMBER STRUCTURES

THE EFFECT OF RATE OF TESTING SPEED ON THE ULTIMATE TENSILE
STRESS OF PLYWOOD

by

C R WILSON and A V PARASIN

Council of Forest Industries of British Columbia

Vancouver

STOCKHOLM, SWEDEN - FEBRUARY/MARCH 1977

THE EFFECT OF RATE OF TESTING SPEED
ON THE ULTIMATE TENSILE STRESS OF PLYWOOD

Background

The June 1976 Draft of the proposed CIB/RILEM "Methods of Test for the Determination of Mechanical Properties of Plywood" standard bases the rate of load application on a rate of strain that is the same for all tests. This differs from the ASTM philosophy where the time to failure (3 - 10 minutes) is used for the basis with which to determine the rate of load application. Because of the way in which plywood reacts to different loads, the ASTM rate differs from the proposed CIB/RILEM rate for the different tests.

Current experimental data on time effect is rather limited and as several individuals on the ASTM D07-03 Plywood Subcommittee have attached importance to the time failure concept, it was felt that an indicative type of test program was warranted to investigate the effect of rate of testing on at least one plywood property.

Objective

To evaluate the effect of rate of testing speed on the ultimate tensile stress of plywood by testing "matched" specimens obtained from a single panel.

Selection and Preparation of Test Specimens

Four groups of 10 panels (5 ply - 1/2 inch - 1/10 inch plies) manufactured in accordance with CSA Standard 0121-1973 Douglas Fir Plywood were randomly sampled from routine mill production of four mills (ten panels per mill). After delivery to the laboratory the panels were examined for uniformity of grade and were number coded and cut as shown in Figure 1. Typical specimens are found in Plate 2.

In addition to the above, it was felt that the number of matched pairs of specimens was relatively low (40) for in-grade type of plywood with variability of ultimate tensile stress in the neighbourhood of 19%. Therefore, to eliminate the possible bias which could have been caused by a lack of matching of pairs due to the defect distribution, twenty panels (5 ply - 1/2 inch - 1/10 inch plies) were custom-made from "defect free" clear Douglas fir veneers.

After delivery to the laboratory, panels were examined for uniformity of grain orientation along the length of the panel. Three panels were rejected as grain distortion made them unsuitable for "matched" specimen tests. Each of the remaining panels were number coded and cut as shown in Figure 1.

Test Procedures

Tests were conducted following the requirements of

ASTM D3500-76 Testing Plywood in Tension, Method B.

Strain rates were 0.003 in/in/min and 0.001 in/in/min for the CIB/RILEM rate and for the ASTM rate respectively.

Plate 1 provides a visual picture of the test set up. Plates 3 and 4 show typical failed tension specimens from the in-grade and "defect free" plywood panels respectively. In addition, individual ply thickness measurements, moisture content, and specific gravity tests were determined for each panel.

Presentation of Test Results

The test results are presented in Tables 1 and 2 for the in-grade and "defect free" plywood panels respectively.

Discussion of Results

Since the parallel ply theory reasonably well approximates the actual stresses exerted within wood fibres, results calculated by this theory will be referred to during this discussion. Results calculated by full cross section theory are presented for comparative purposes.

Results in Table 1 indicate that for in-grade Douglas fir plywood the mean and the 5% exclusion value of ultimate tensile stress are greater by 6.1% and 4.8% respectively at a strain rate of 0.003 in/in/min than at a strain rate of 0.001 in/in/min. The coefficient of variation has not been practically affected by the difference in strain rate.

Results in Table 2 indicate that for "defect free" Douglas fir plywood the mean and the 5% exclusion value of ultimate tensile stress are greater by 12.3% and 17.7% respectively at a strain rate of 0.003 in/in/min than at a strain rate of 0.001 in/in/min. The larger difference in the 5% exclusion value than in the mean value was caused by the decrease of C.V. from 13.3% to 11.0%.

As expected, the difference in strain rate had greater effect on clear than on in-grade plywood. This difference in the intensity of effect is probably caused by lower sensitivity to strain rate of lower strength - lower stiffness areas around knots which develop micro failures earlier than the other portions of wood during the straining-stressing process.

The average time till failure was for both in-grade and "defect free" specimens approximately one minute thirty seconds at 0.003 in/in/min strain rate and approximately four minutes thirty seconds at 0.001 in/in/min.

The number of tested matched pairs of specimens was not large enough to provide a basis for statistically fully justified comparisons. Nevertheless, for both in-grade and "defect free" specimens tested, the trend is the same and it strongly indicates that the strain rate increase from 0.001 in/in/min to 0.003 in/in/min causes an appreciable increase in ultimate tensile stress.

Conclusions

Based on the results of this indicative test program, the following can be concluded.

- (1) The mean and the 5% exclusion value of the ultimate tensile stress of Douglas fir type of in-grade plywood are greater by 6.1% and 4.8% respectively at 0.003 in/in/min strain rate than at 0.001 in/in/min strain rate.
- (2) The mean and the 5% exclusion value of ultimate tensile stress for clear "defect free" softwood type of plywood are greater by 12.3% and 17.7% respectively at 0.003 in/in/min strain rate than at 0.001 in/in/min strain rate.
- (3) The average time elapsed till failure for tension tests on both "defect free" and in-grade softwood plywood is approximately 1-1/2 min at 0.003 in/in/min strain rate and approximately 4-1/2 min at 0.001 in/in/min strain rate.

Recommendations

As the data developed from this program indicates that the strain rate influences the strength results and as the strain rate of 0.003 in/in/min results in undesirably short average time to failure (1-1/2 min), it is recommended that testing speed be indirectly specified by stating the desirable average time to failure with specified lower and upper limits. The above approach is warranted by the fact that strength properties determined by static tests are adjusted to either "normal duration" or "long term duration" allowable values by one single factor applied to the different strength properties.

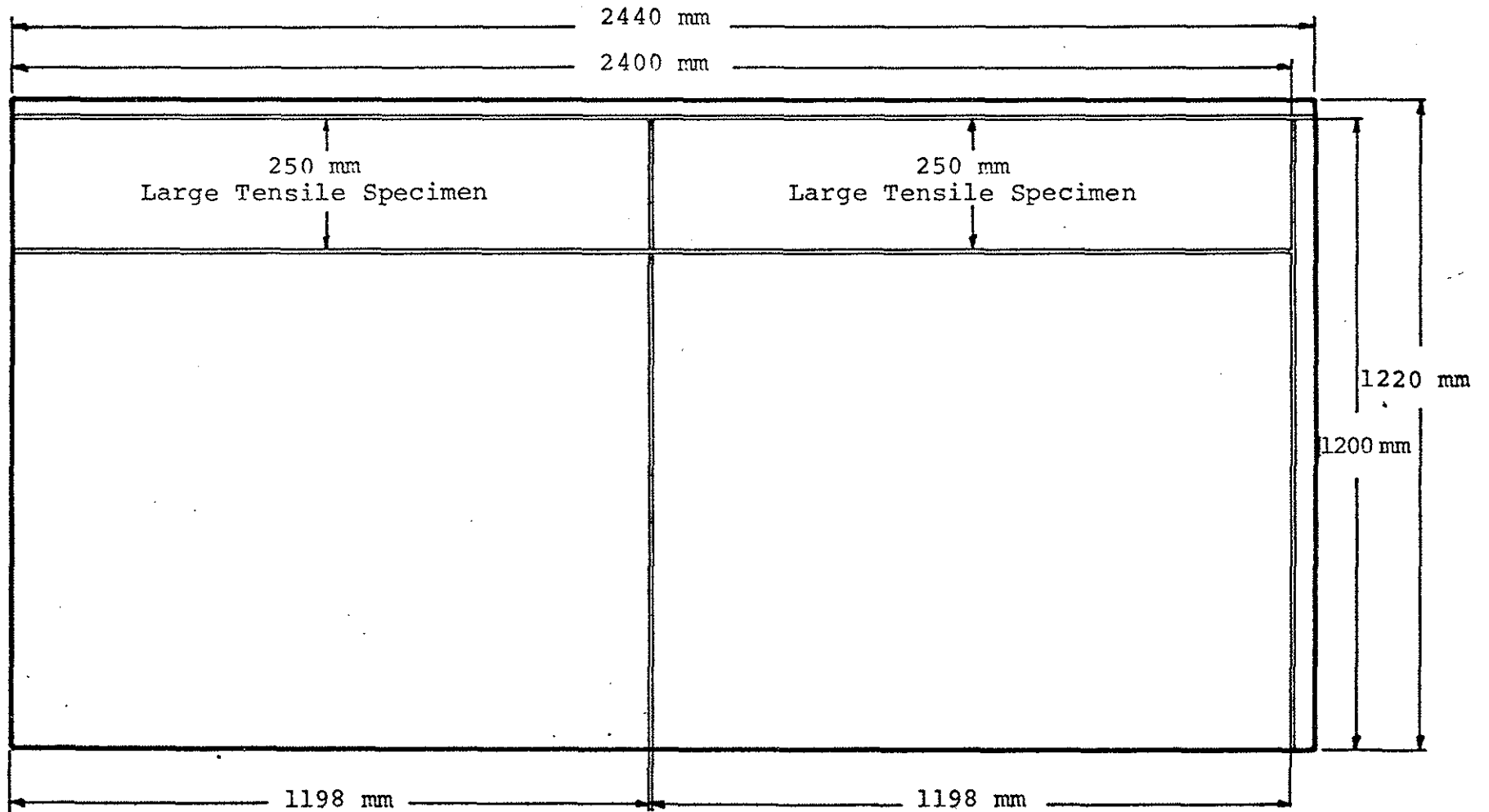

Figure 1. CUTTING PLAN

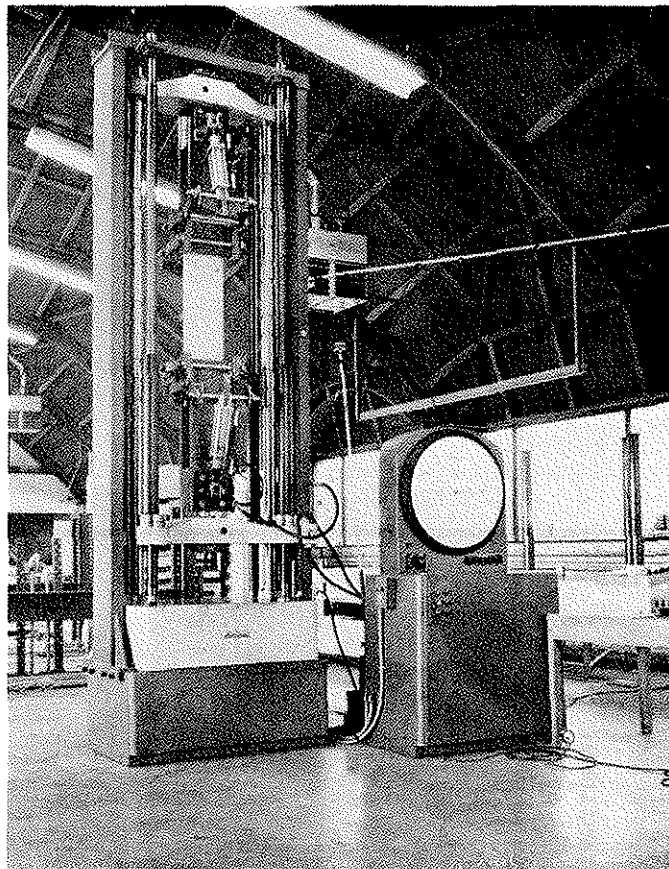

PLATE 1
TENSION TEST

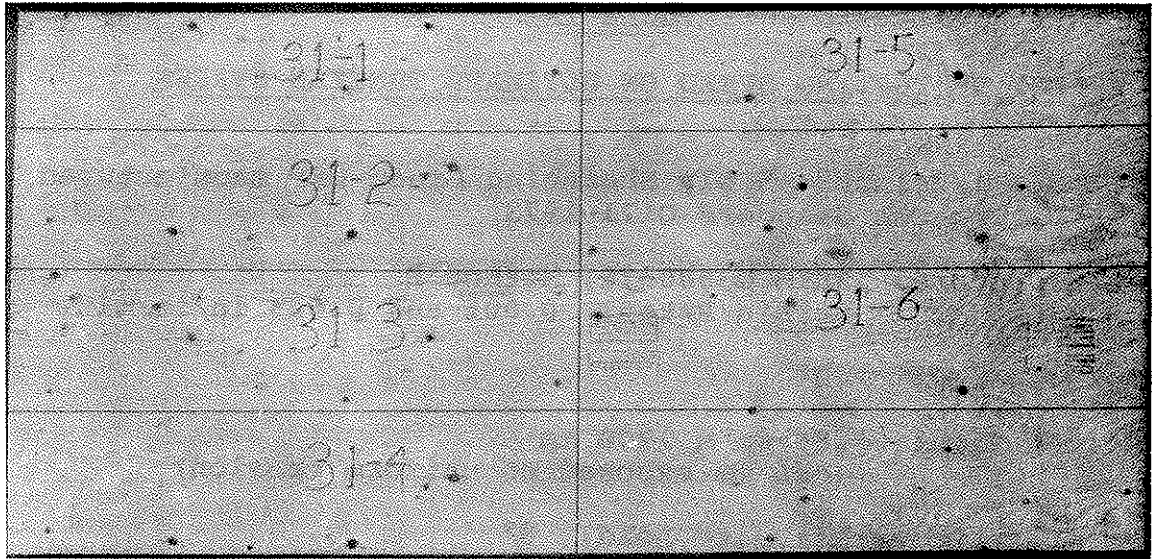

PLATE 2

TYPICAL SPECIMENS IN AN IN-GRADE PLYWOOD PANEL BEFORE CUTTING
 (only specimens 31-1 & 31-5 were tested in tension)

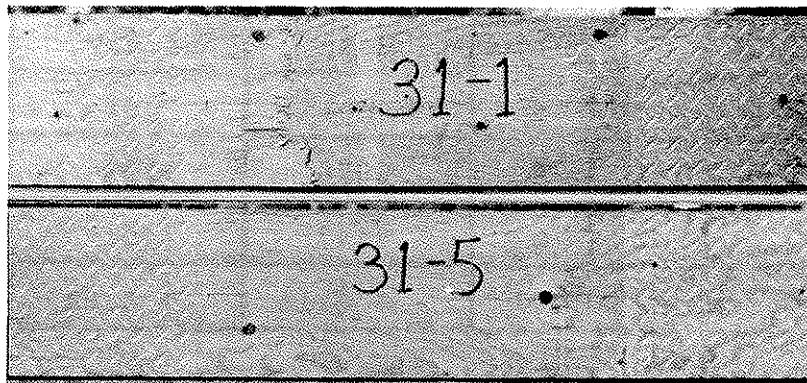

PLATE 3

TYPICAL FAILED TENSION SPECIMENS
 FROM THE PLYWOOD PANEL SHOWN IN PLATE 2



PLATE 4

TYPICAL FAILED TENSION SPECIMEN
 FROM THE "DEFECT FREE" PLYWOOD PANEL

TABLE 1EFFECT OF TESTING SPEED ON ULTIMATE TENSILE STRESS

Plywood: 1/2 inch - 5 ply Sheathing Grade DFP manufactured to CSA Standard 0121-1973

Test Procedure: ASTM D3500-76, Method B
Strain Rates: 0.001 and 0.003 in/in/min

Panels Tested: 40

Specimen Size: 250 mm x 1200 mm
(640 mm exposed to uniform tension)

Face Grain Orientation to Load: 0°

Parallel Ply Theory

Strain Rate	No. of Specimens	Designation	Ultimate Tensile Stress		
			Mean	5% e.v.	C.V.
in/in/min			psi	psi	%
0.001	40	A	6076	4199	18.8
0.003	40	B	6447	4401	19.3
Difference $\frac{B-A}{A}$ 100			+ 6.1%	+ 4.8%	-

Full Cross Section Theory

Strain Rate	No. of Specimens	Designation	Ultimate Tensile Stress		
			Mean	5% e.v.	C.V.
in/in/min			psi	psi	%
0.001	40	A	3653	2543	18.5
0.003	40	B	3880	2727	18.1
Difference $\frac{B-A}{A}$ 100			+ 6.2%	+ 7.2%	-

TABLE 2EFFECT OF TESTING SPEED ON ULTIMATE TENSILE STRESS

Plywood: 1/2 inch - 5 ply Sheathing DFP manufactured with clear (defect free) veneers

Test Procedure: ASTM D3500-76, Method B
Strain Rates: 0.001 and 0.003 in/in/min

Panels Tested: 17

Specimen Size: 250 mm x 1200 mm
(640 mm exposed to uniform tension)

Face Grain Orientation to Load: 0°

Parallel Ply Theory

Strain Rate	No. of Specimens	Designation	Ultimate Tensile Stress		
			Mean	5% e.v.	C.V.
in/in/min			psi	psi	%
0.001	17	A	6713	5243	13.3
0.003	17	B	7540	6173	11.0
Difference		$\frac{B-A}{A} 100$	+12.3%	+17.7%	-

Full Cross Section Theory

Strain Rate	No. of Specimens	Designation	Ultimate Tensile Stress		
			Mean	5% e.v.	C.V.
in/in/min			psi	psi	%
0.001	17	A	4041	3149	13.4
0.003	17	B	4506	3792	9.6
Difference		$\frac{B-A}{A} 100$	+11.5%	+20.4%	-

CIB-W18/7-4-4

INTERNATIONAL COUNCIL FOR BUILDING RESEARCH STUDIES AND DOCUMENTATION
WORKING COMMISSION W18 - TIMBER STRUCTURES

COMPARISON OF THE EFFECT OF SPECIMEN
SIZE ON THE FLEXURAL PROPERTIES OF
PLYWOOD USING THE PURE MOMENT TEST

by

C R WILSON and A V PARASIN

Council of Forest Industries of British Columbia
Vancouver

STOCKHOLM, SWEDEN - FEBRUARY/MARCH 1977

COMPARISON OF THE EFFECT OF SPECIMEN SIZE
ON THE FLEXURAL PROPERTIES OF PLYWOOD
USING PURE MOMENT TEST

Background

At a recent CIB W18 meeting (Aalborg, June 1976) it was agreed that the pure moment test as presented in the July, 1976 draft of the CIB/RILEM "Methods of Tests for the Determination of Mechanical Properties of Plywood" Standard be used to determine the bending stiffness and ultimate moment capacity of a plywood panel. It was also agreed that the test specimen should not be a "small clear" specimen but should be of a size sufficient to contain natural and manufacturing characteristics allowable in the appropriate product standard.

The July 1976 draft of the CIB/RILEM testing standard requires three individual specimens of a width 300 mm to be selected from a panel in accordance with a specified cutting schedule. These specimens are then exposed to the pure moment over an area of 300 mm x 300 mm to determine the basic stiffness and strength of the plywood panel. Such a specimen, of 300 mm width, is commonly identified as a medium sized specimen which differs to the large sized specimens, of 1200 mm in width, commonly tested in Canada.

As a plywood panel is almost always used in its full width, we believe that it is a realistic requirement that the bending test uses a full width panel or something approaching full width. Recognizing the concern for using generally available commercial equipment, we agree that the standard should at least provide for an option to the full width panel. This paper suggests such an option.

Objective

To evaluate the effect of size of specimen on plywood bending strength and stiffness by testing 3 - 300 mm wide medium sized specimens versus 1 - 900 mm wide large sized specimen using "matched" specimens obtained from a single panel and tested by the pure moment test.

Selection and Preparation of Test Specimens

Four groups of 10 panels (5 ply - 1/2 inch - 1/10 inch plies) manufactured in accordance with CSA Standard O121-1973 Douglas Fir Plywood were randomly sampled from routine mill production of four mills (ten panels per mill).

After delivery to the laboratory panels were examined for uniformity of grade. One panel was rejected as grain distortion and knot characteristics made it unsuitable for "matched" specimen tests. Each of the remaining panels were number coded and cut as shown in Figure 1. Typical specimens are found on Plate 3.

Test Procedures

Tests were conducted following the requirements of

ASTM D3043-72 Standard Methods of Testing Plywood in
Flexure, Method C, Pure Moment Test
for Large Specimens.

Plate 1 and 2 provide a visual picture of the test set up. Plate 4 shows typical failed bending specimens from a plywood panel.

In addition, individual ply thickness measurement, moisture content, and specific gravity tests were determined for each panel.

Presentation of Test Results

The modulus of rupture and modulus of elasticity test results are presented in Tables 1 and 2 using the calculation procedure of parallel ply theory (neglecting the contribution of perpendicular plies in calculating section properties) and the full cross section theory respectively.

Results were determined for the 39 - 900 mm wide specimens, 117 - 300 mm wide specimens and the 39 - 300 mm specimens using the technique of determining within panel average of the 300 mm wide specimen test.

Discussion of Results

The nature of this test program was to provide an indication on the effect of specimen size on the flexural properties of plywood.

Modulus of Rupture

The mean modulus of rupture for 300 mm wide specimens was, as expected, lower than for 900 mm wide specimens. Detailed visual examination of the location of failure in respect to the groups or rows of knots and knotholes revealed that in 900 mm wide specimens the load was sidewise transferred from "weaker" areas to stronger and stiffer areas.

This observation can be readily supported theoretically since the strain in outermost fibres is approximately constant across the width of the specimen. Consequently, the less stiff (and weaker) portions of the cross section of any ply will generate lower stress than the stiffer (and stronger) portions of the cross section of any ply, both being strained equally.

The relationship of fifth percentiles (5% exclusion values) for modulus of rupture was affected by the absolute level of values, as discussed above, and by variabilities which are mainly due to

- (1) physical characteristics of the specimen, and
- (2) statistical treatment.

(1) Physical Characteristics of the Specimen

The most active of physical characteristics of the specimen are:

- (a) the ratio of the loss of the wood cross section (due to knots and knotholes) to the total width of the specimen,
- (b) the type of knot and knothole distribution in relationship to the width and length of specimen,
- (c) the type of grain distortion around knots and knotholes.

Factor (a) is partially and factors (b) and (c) are fully a function of species.

- (a) Generally, large loss of cross section in a panel produces large differences in strength between 300 mm wide specimens and hence increases the C.V. for medium specimens versus large specimens.
- (b) Panels with many small (or no knots) would produce relatively smaller variability for 300 mm specimens than species with fewer but larger knots. Consequently, one could expect the variability for 300 mm specimens to be only slightly greater than for 900 mm wide specimens for plywood with "small, densely distributed knots" and one could expect much larger difference in C.V. for plywood with fewer but larger knots.

- (c) Grain distortion is in respect to its effect on strength, an extension of knot or knothole. Effects of knots and knotholes discussed as factors (a) and (b) are enhanced in species with extensive grain distortion.

When the analysis of factors involved is directly applied to the results shown in Table 1, it can be seen that for Douglas fir plywood with medium size and medium densely distributed knots and knotholes, one would expect a medium decrease of mean modulus of rupture and medium increase of its variability from 900 mm to 300 mm specimens. The -7.6% difference in mean is about the minimum expected difference. The increase of variability from 19.1% to 20.6% (for MOR) is smaller than expected. The difference was reversely affected by statistical treatment as will be explained below.

(2) Statistical Treatment

One 900 mm specimen and three 300 mm specimens were cut from each panel. If only one 300 mm specimen was tested, the difference of variability between A and B (Table 1) would be greater. Larger number of specimens (117) improved the statistical sample size of B and caused a lower C.V. than would be produced by testing of only 39 - 300 mm wide specimens.

When MOR for 3 - 300 mm specimens from each panel was averaged and panel average was used as single statistical observation (C - Table 1), the statistical size of sample was decreased from 117 to 39 but the effect of this was overwhelmed by "the averaging effect" which removed very high and very low extreme values and resulted in a lower variability of 17.9%.

Since C.V. for B (20.6%) is greater and C.V. for C (17.9%) is smaller than C.V. for A (19.1%), the corresponding differences in fifth percentile are greater (-11.1%) and smaller (-5.1%) than that for the mean (-7.6%).

Modulus of Elasticity

Modulus of elasticity (MOE) is determined from the slope of the moment-deflection curve at stresses not greater than one-third of the ultimate stress. Consequently, MOE is in general less affected by the discussed physical characteristics of the specimen than MOR. The decrease of the mean MOE of -7.1% from the 900 mm to the 300 mm wide specimen

is only 0.5% less than for MOR (-7.6%). This small "difference between differences" of mean MOE and mean MOR was unexpected and is probably caused by the small sample size (39 panels).

The lower effect of physical characteristics of specimen on MOE was very evident in coefficients of variation where C.V. for B (10.6%) is lower than C.V. for A (15.7%). The difference is caused by difference in sample size and was influenced by the reverse effect of physical characteristics of specimen to a lesser degree than in the case of MOR.

The relative position of C.V. for B (10.6%) and C (8.6%) is about the same as for MOR and is caused by averaging effect.

Conclusions

Based on the results of this indicative test program the following can be concluded.

- (1) The mean modulus of rupture and the mean modulus of elasticity are approximately 7% lower for 300 mm wide specimens than for 900 mm wide specimens.
- (2) The fifth percentile of modulus of rupture is lower for 300 mm wide specimens than for 900 mm wide specimens by approximately 11% when statistics are based on individual specimen values and by approximately 5% when statistics are based on individual panel averages for 300 mm wide specimens.

Recommendations

As the 900 mm wide specimen better describes the "in service" strength of the plywood tested, it is recommended that the CIB/RILEM Standard require the testing of a 900 mm wide specimen. To ensure that conventional laboratory equipment can be used, it is recommended that this "900 mm wide" specimen be 900 mm wide or 2 - 450 mm wide or 3 - 300 mm wide (the "2" or "3" specimens being cut from the original 900 mm wide specimen).

In using the "2" or "3" specimens the difference in 5% e.v. of MOR is minimal providing the individual results are averaged to determine the resulting individual panel strength. In addition, it can be anticipated that plywoods with smaller number of small knots or knotholes than the Douglas fir plywood tested would have smaller (and probably negligible) difference in flexural strength between the 300 mm and 900 mm wide specimens.

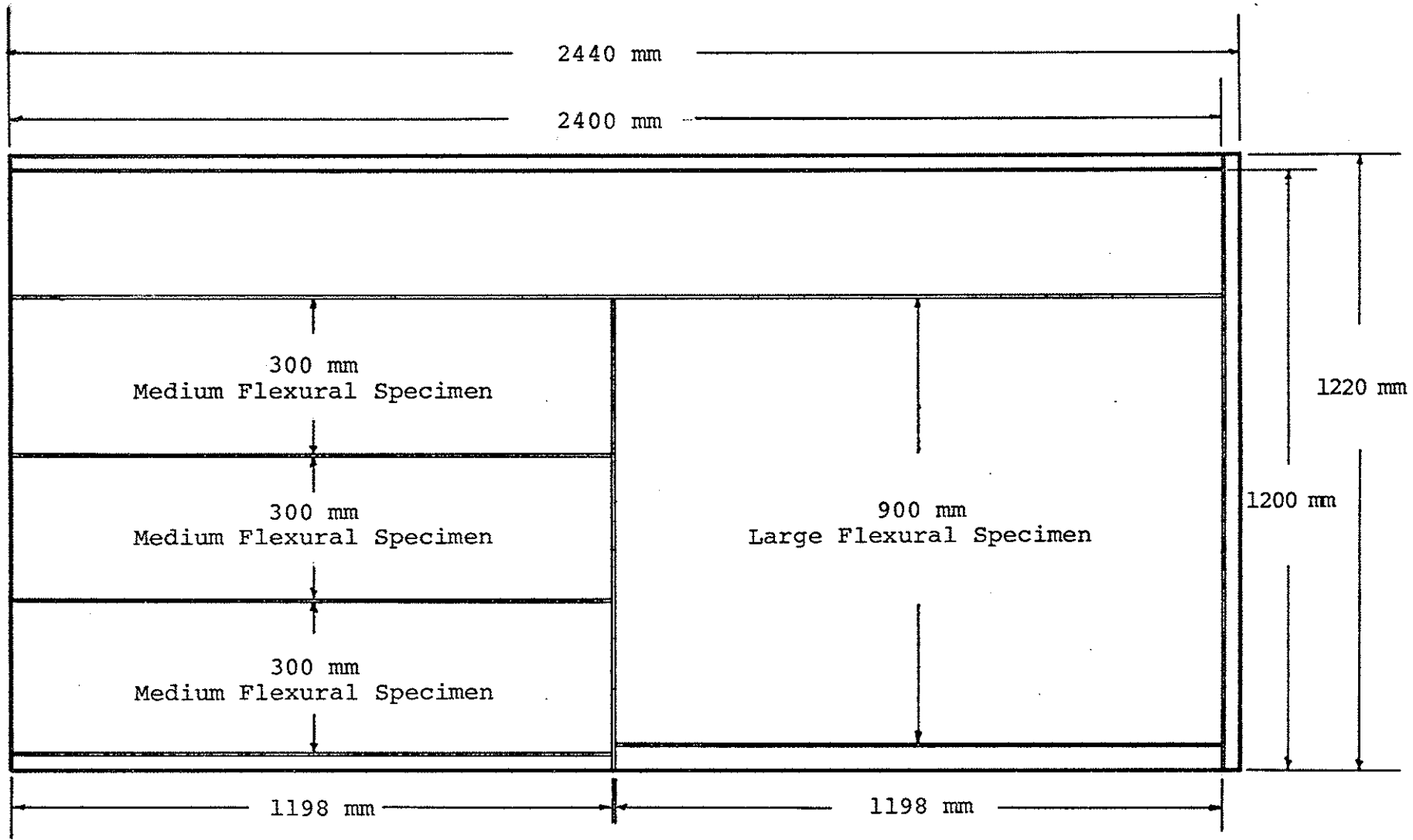

Figure 1. CUTTING PLAN



PLATE 1
PURE MOMENT FLEXURE TEST

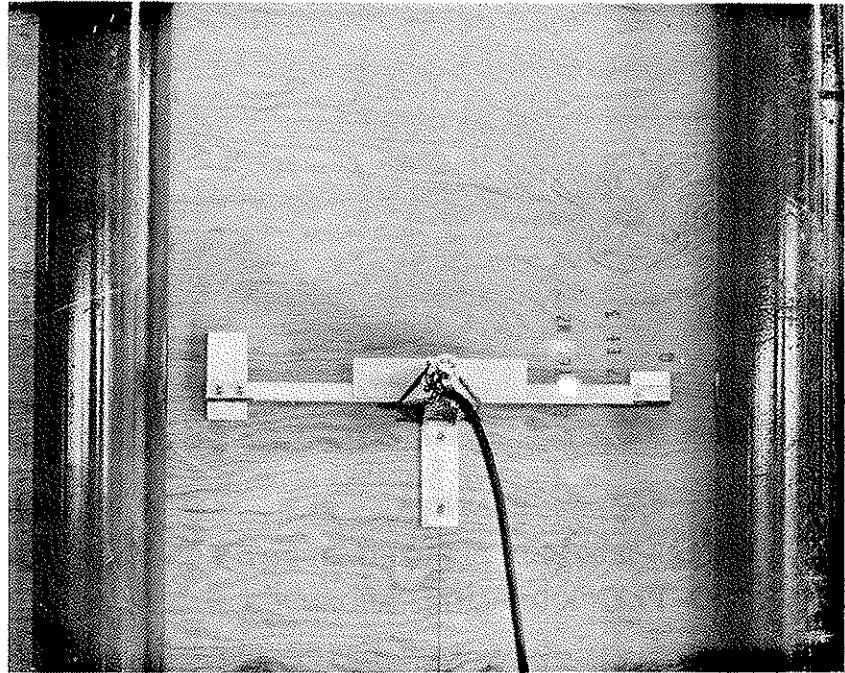

PLATE 2
DEFLECTION MEASURING DEVICE
FOR PURE MOMENT FLEXURE TEST



PLATE 3
TYPICAL SPECIMENS IN AN IN-GRADE PLYWOOD PANEL
BEFORE CUTTING

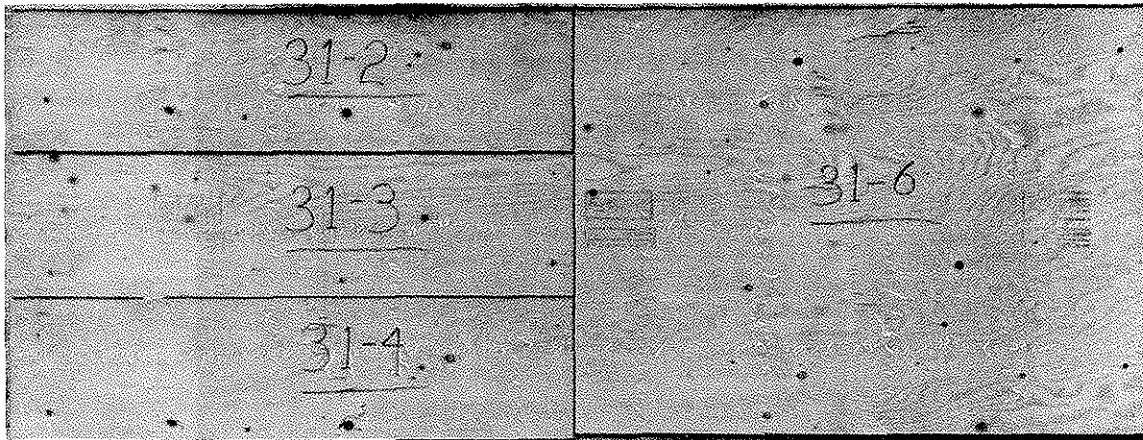

PLATE 4
TYPICAL FAILED BENDING SPECIMENS
FROM THE PLYWOOD PANEL SHOWN ON PLATE 3

TABLE 1EFFECT OF SPECIMEN SIZE ON FLEXURAL PROPERTIES

(Parallel Ply Theory)

Plywood: 1/2 inch - 5 ply Sheathing Grade DFP manufactured
to CSA Standard O121-1973

Test Procedure: ASTM D3043-72, Method C

Panels Tested: 39

Specimen Sizes: 300 mm x 1200 mm
900 mm x 1200 mm
(600 mm length exposed to pure moment)

Face Grain Orientation to Span: 0°

WIDTH OF SPECIMEN	NO. OF SPECIMENS	NO. OF PANELS	STATISTICS BASED ON VALUES FOR	DESIGNATION	MODULUS OF RUPTURE			MODULUS OF ELASTICITY	
					MEAN	5% e.v.	C.V.	MEAN	C.V.
mm					psi	psi	%	psi	%
900	39	39	SPECIMEN	A	8332	5718	19.1	2265730	15.7
300	117	39	SPECIMEN	B	7694	5085	20.6	2105000	10.6
300	39	39	PANEL AVG.	C	7694	5425	17.9	2105000	8.6
DIFFERENCE $\frac{B-A}{A} 100$					-7.6%	-11.1%		-7.1%	
DIFFERENCE $\frac{C-A}{A} 100$					-7.6%	-5.1%		-7.1%	

TABLE 2EFFECT OF SPECIMEN SIZE ON FLEXURAL PROPERTIES

(Full Cross Section Theory)

Plywood: 1/2 inch - 5 ply Sheathing Grade DFP manufactured
to CSA Standard 0121-1973

Test Procedure: ASTM D3043-72, Method C

Panels Tested: 39

Specimen Sizes: 300 mm x 1200 mm
900 mm x 1200 mm
(600 mm length exposed to pure moment)

Face Grain Orientation to Span: 0°

WIDTH OF SPECIMEN	NO. OF SPECIMENS	NO. OF PANELS	STATISTICS BASED ON VALUES FOR	DESIGNATION	MODULUS OF RUPTURE			MODULUS OF ELASTICITY	
					MEAN	5% e.v.	C.V.	MEAN	C.V.
mm					psi	psi	%	psi	%
900	39	39	SPECIMEN	A	6573	4629	18.0	1786590	13.5
300	117	39	SPECIMEN	B	6118	4066	20.4	1674700	10.4
300	39	39	PANEL AVG.	C	6118	4341	17.6	1674700	8.2
DIFFERENCE $\frac{B-A}{A} 100$					-6.9%	-12.2%		-6.3%	
DIFFERENCE $\frac{C-A}{A} 100$					-6.9%	-6.2%		-6.3%	

INTERNATIONAL COUNCIL FOR BUILDING RESEARCH STUDIES AND DOCUMENTATION

WORKING COMMISSION W18 - TIMBER STRUCTURES

STRENGTH AND LONG-TERM BEHAVIOUR OF
LUMBER AND GLUED-LAMINATED TIMBER
UNDER TORSION LOADS

by

K MOHLER

Universität Karlsruhe (TH)

Karlsruhe

1. Aim of the Research Work

In modern wood-constructions especially with glued laminated timber the wooden members are often strained by torsional loading. Therefore they must be designed to withstand these stresses. Publications concerning the torsional strength and the distortion-behavior of larger wood-structures can hardly be found. The German design standard as well as the standards of other countries give no special values for the allowable torsional stresses and the torsion modulus of large sections of lumber and glued laminated timber. Finally no methods for the calculation of the torsional stresses and the distortions are known for the anisotropic material wood, having natural faults. The methods, published until now were only applicable ^{to} the faultless wood rod which has a fixed position to the rings and the grain direction. The necessary values for designing torsional members could only be gained by tests with samples of real sizes. Therefore it was the aim of this research work to determine values for the torsional strength and the torsion modulus of timber and glued laminated timber cross-sections using structural wood. Also the influence of duration of loads had to be observed. Besides this, for glued laminated timber, the bearing- and distortion behavior, by simultaneously acting of torsion-, bending- and shear-stresses should be investigated.

2. Mathematical Treatment of the Torsional Problem for the Anisotropic Building Material Wood

The study of the literature, especially of the works of Voigt [1], Horig [2] and Krabbe [3] had the result that the calculation of stresses and distortions by the model of Voigt's crystal-theory (wood is adspected as a rhombic crystal building material) is useless for practical calculations in wood construction, because on one hand a big expense in calculation is necessary and on the other hand the assumptions don't hold true for bigger dimensions and for the presence of faults in the grain. Therefore it would be better to use the isotropic view which in general is known by each engineer. It had

to be proved by tests in what way the ratio of the depth to the width for the common rectangular cross-section and the timber grade were influencing τ_{TB} and G_T .

3. Results of the Tests

3.1 Torsional Strength τ_{TB} by Short-Time Loading

By timber specimens without any faults and with circular or square cross-sections the mean values of the calculated torsional strength were 10,3 and 12,6 N/mm² and the 5%-fractiles were 8,9 and 10,0 N/mm². Increasing the ratio of the depth to the width the values rose. Besides this a very good linear dependence of the density ρ (figure 1) and of the moisture content ω (figure 2) could be found. In both cases with rising values ρ and ω an increase of τ_{TB} appeared, which however was different in the singular series of the tests. Using timber of the grades I and II a distinct decrease contrary to the specimens without faults was seen. Thereby hardly no difference appeared between quality I and II (figure 3). The torsional strength of wood without faults was about 75% more than the values of grade I and II.

For glued laminated timber of quality I/II with the same dimension the mean values were still a little lower, but the deviations were minor, so that the 5%-fractiles were higher than the values for timber.

Simultaneously acting shear loads (shear and bending stresses) only develop a decrease of the torsional strength when $\tau_V > 0,9$ N/mm² (figure 4). Bending stresses alone had no decreasing influence. Also with timber of quality I/II and glued laminated timber of the same dimensions an influence of the width to the depth ratio could be noticed by the 5%-fractiles. This influence however was often covered by faults in the grain. It can be assumed that for normal sections of glued laminated wood the torsional strength is about 40% higher than that of squared sections.

3.2 Torsional Strength τ_{TBt} Under Duration of Loads

Regarding the duration of loads, a similar decrease of the short-time torsion-

strength was found in the same way as by the other short-time strengths. This relationship for timber reads

$$\tau_{TD} = \tau_{TB} (t = 1h) \cdot [1 - 0,0562 \cdot \lg(t)] \quad (\text{figure 5}).$$

For glued laminated timber a similar behavior can be assumed. A test using stresses which were about 78% to 90% of the ultimate strength of a short-time test, led to rupture by a time of 864 hours. On the other hand in tests with stresses, which were about 39% and 55% of the short-time strength, even after a time of 1.3 years no sign of rupture could be noticed. This could be expected from looking at figure 5. The test specimens even reached the same torsional strengths as the values which were found in the pure short-time tests done before. A decreasing influence of the preceding long time loading could not be noticed.

3.3 Torsion Modulus G_T

By the plotted load-distorsion lines the G_T - values were calculated with the equation $G_T = M_T \cdot L / \varphi \cdot I_T$ for the straightlined part of the M_T / φ - lines. The proportional limit was about 50% to 65% of the ultimate values. A significant relation of the mean value of the G_T - modulus from the depth to the width ratio was shown by timber and also by glued laminated timber (figure 6). Similar dependences as seen by the torsional strength were noticed by the density ρ (figure 7) and by the grade of the timber (figure 8). Besides this a small decrease was observed with increasing humidity.

In practice using the specimens without faults and with circular and square cross-sections the same mean value of $G_T = 560 \text{ N/mm}^2$ was obtained. For grade I/II the value decreased to $410,5 \text{ N/mm}^2$ for timber

and to $491,5 \text{ N/mm}^2$ for glued laminated timber. If simultaneously bending-shear loads were acting, a decrease of G_T was observed for glued laminated timber, while pure bending had no recognizable decreasing influence on G_T .

Under long term loading for timber and also for glued laminated timber a significant decrease of G_T could be noticed, which was greater for timber than for glued laminated timber.

4. Conclusions

For timber and glued laminated timber with a density of $\rho_{12} \cong 380 \text{ kg/m}^3$ and with a humidity of 12%, using a rectangular cross-section and a depth to the width ratio $h/b \cong 2$ an allowable torsional stress of

$$\text{at } \tau_{TVH} = 1,2 \text{ N/mm}^2$$

for timber and of

$$\text{at } \tau_{TBSH} = 1,6 \text{ N/mm}^2$$

for glued laminated timber could be assumed. Thereby the safety referred to the 5%-fractile values is at least of 2.5. In a simultaneous acting of shear from shear loads these values must be multiplied by the factor

$$k_{\tau V} = 1 - \frac{(\tau_V / \alpha \tau_V)^2}{\alpha^2 \tau_V^2} \quad k_{\tau V} = 1 - (\tau_V / \alpha \tau_V)^2$$

where " τ_V " is the actual shear stress caused by the shear loads.

In practice a shear modulus of $G_T = 330 \text{ N/mm}^2$ for timber and $G_T = 500 \text{ N/mm}^2$ for glued laminated timber could be used.

Literature

- [1] Voigt, W.: Lehrbuch der Kristallphysik.
Leipzig 1928
- [2] Hörig, H.: Tafeln R (p) und Q (p) zur Berechnung der
Gleitzahlen s_{44} , s_{55} und s_{66} und der maximalen Tangentialspannungen.
Berlin 1957
- [3] Krabbe, E.: Messung von Gleit- und Dehnungszahlen an Holz-
stäben mit rechteckigem Querschnitt.
Dissertation TH Hannover, 1960

Universität Karlsruhe
Lehrstuhl für Baukonstruktionen

Eingang 20. FEB. 1978

CORRIGENDUM

77.10.01

CIB-W18 Proceedings: Meeting Seven: Stockholm Feb/March 1977.

mit Zi. 2.

Paper CIB-W18/7-6-1. Strength and Long-term Behaviour of Lumber and Glued-
Laminated Timber under Torsion Loads.

Section 4, Conclusions

The third equation should read:

$$k_{\tau V} = 1 - (\tau_V / a l \tau_V)^2$$

Lehrstuhl für
Ingenieurholzbau u. Baukonstruktionen
Universität (TH) Karlsruhe
Prof. Dr.-Ing. K. Möhler

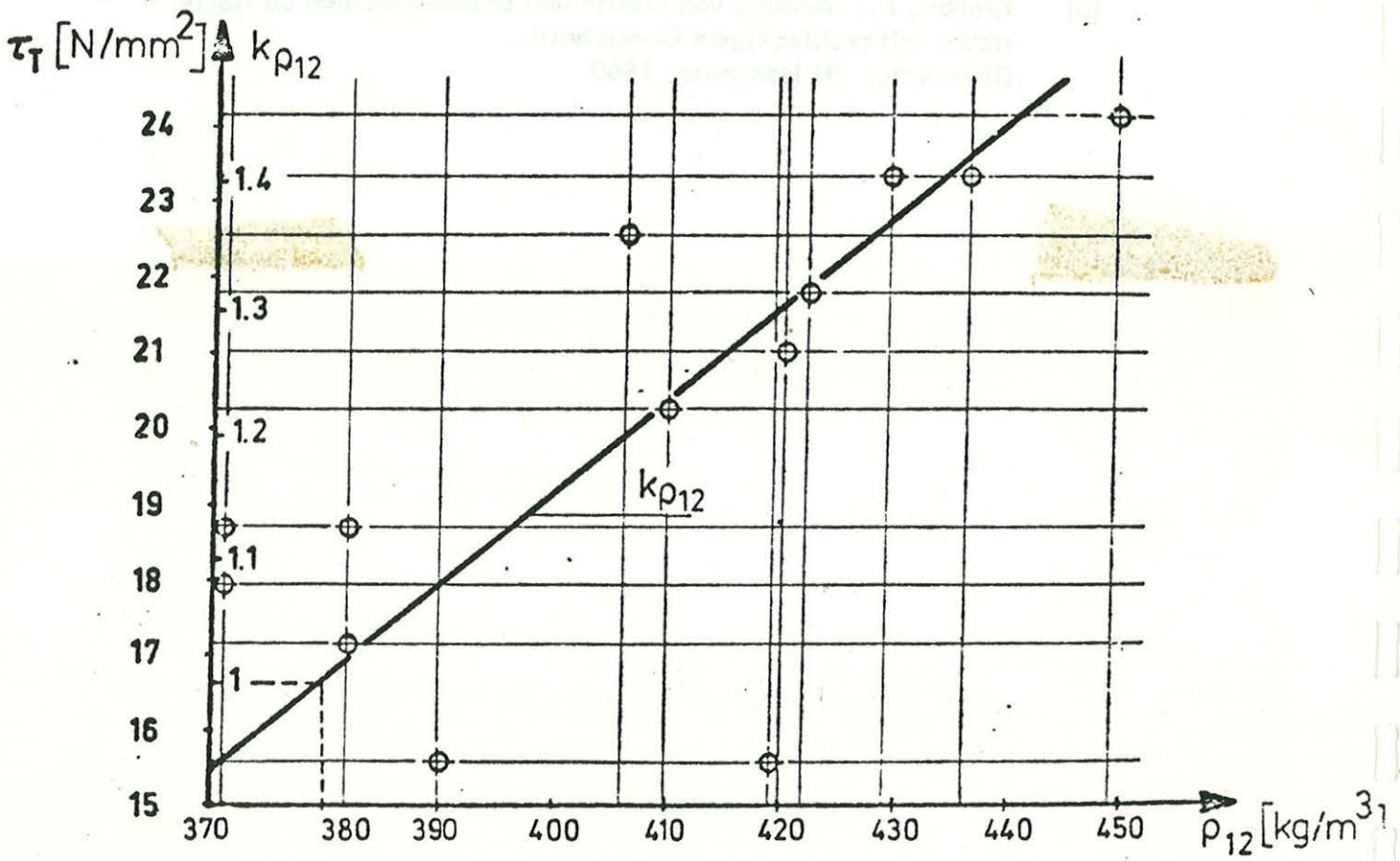

figure 1 : relation between the torsional strength and the density ρ .
(spruce \varnothing 25 mm)

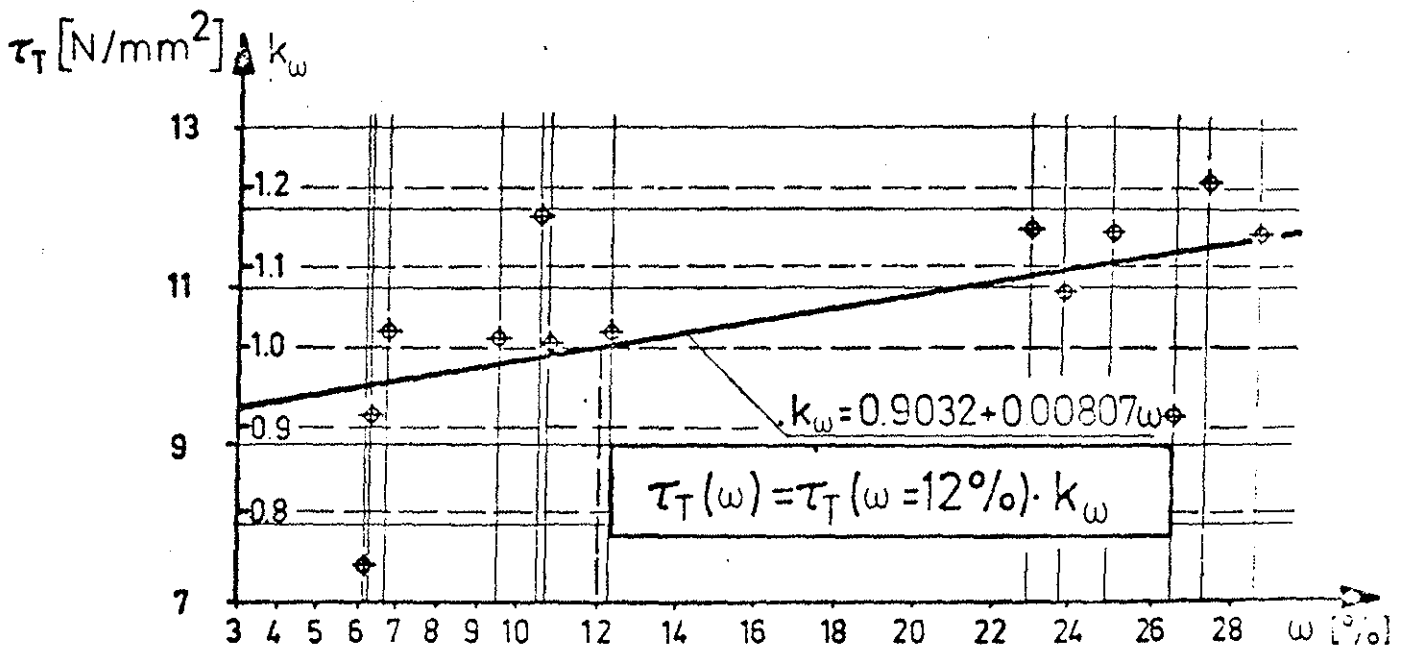

figure 2 : influence of the moisture content to the torsional strength related to $\omega = 12\%$
 (test values related to $\rho_{12} = 380 \text{ kg/m}^3$)

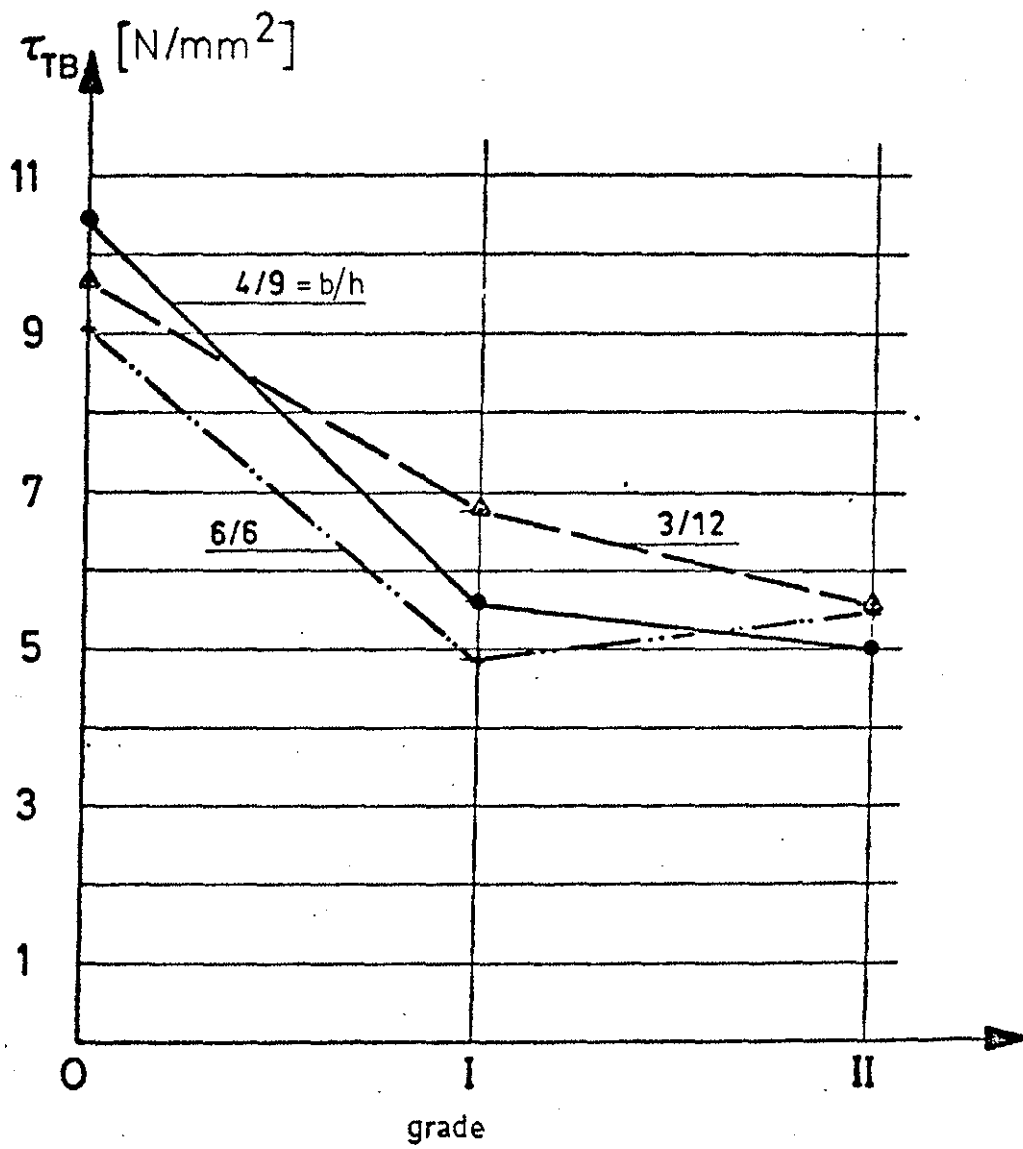

figure 3: relation between the torsional strength and the grade referenced to the German standard DIN 4074 for timber

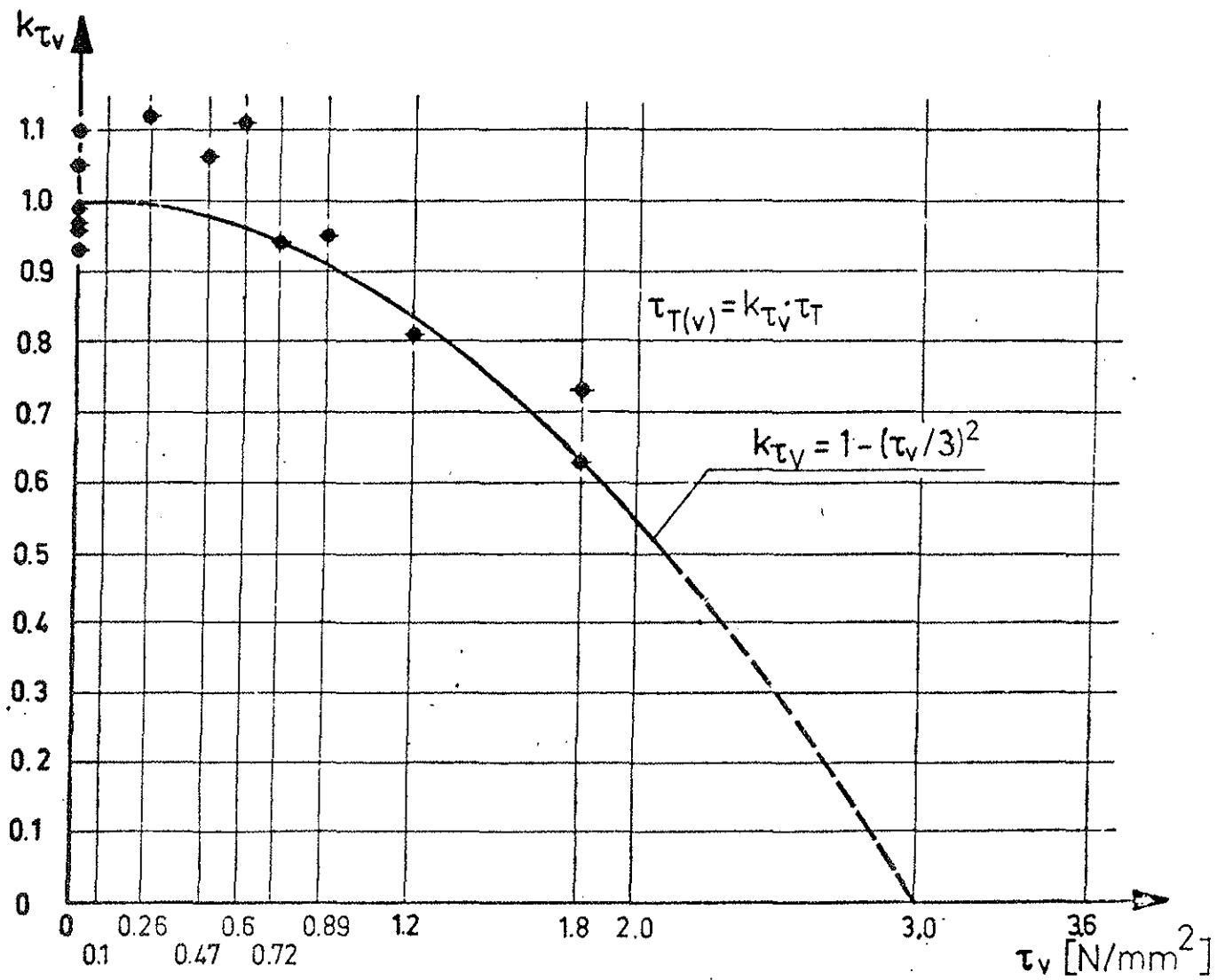

figure 4 : influence of the acting shear stresses, caused by shear forces, to the torsional strength for glued laminated timber

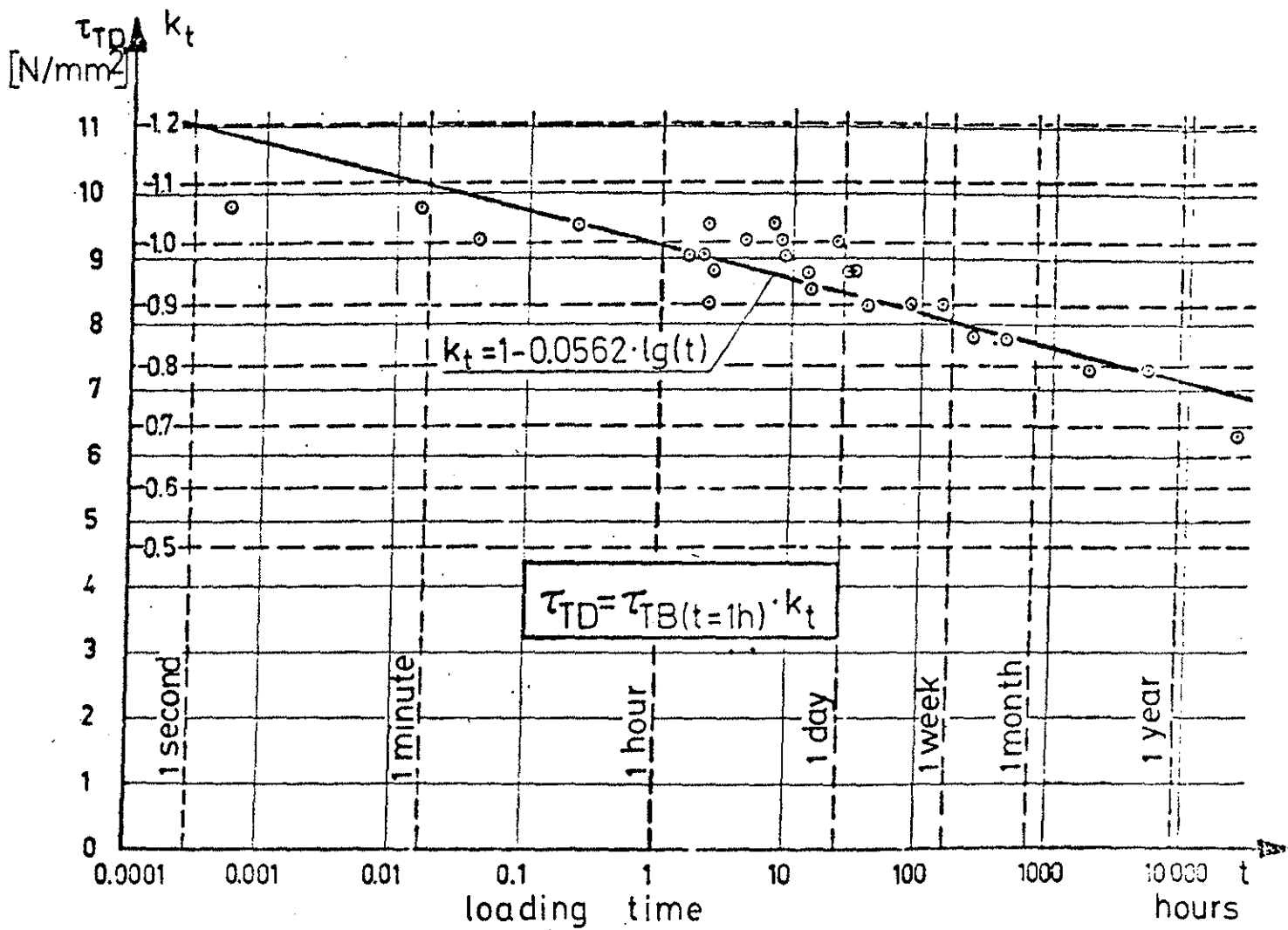

figure 5 : relation between the torsional strength and the loading time (specimens with a circular cross section, spruce \varnothing 25 mm)

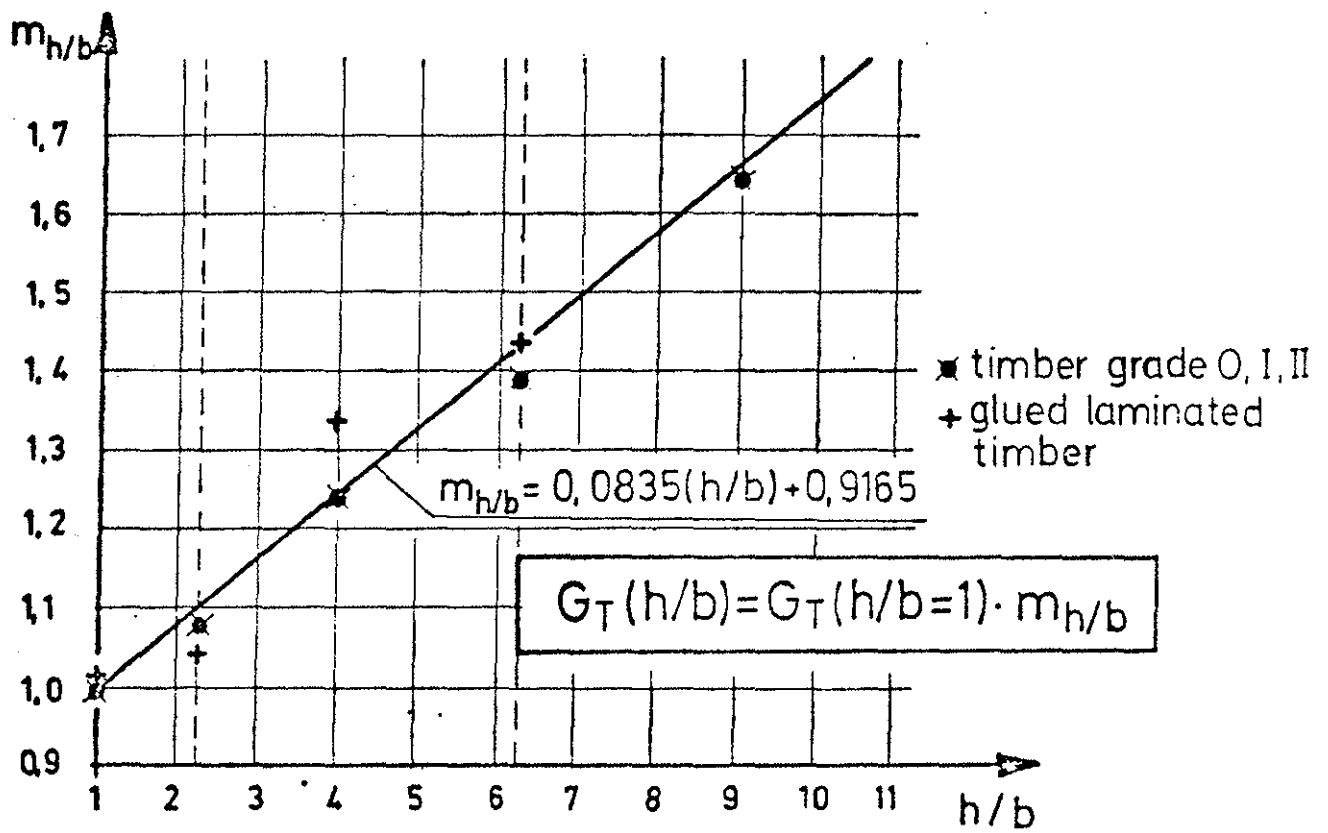

figure 6: influence of the depth to the width ratio to the torsion modulus

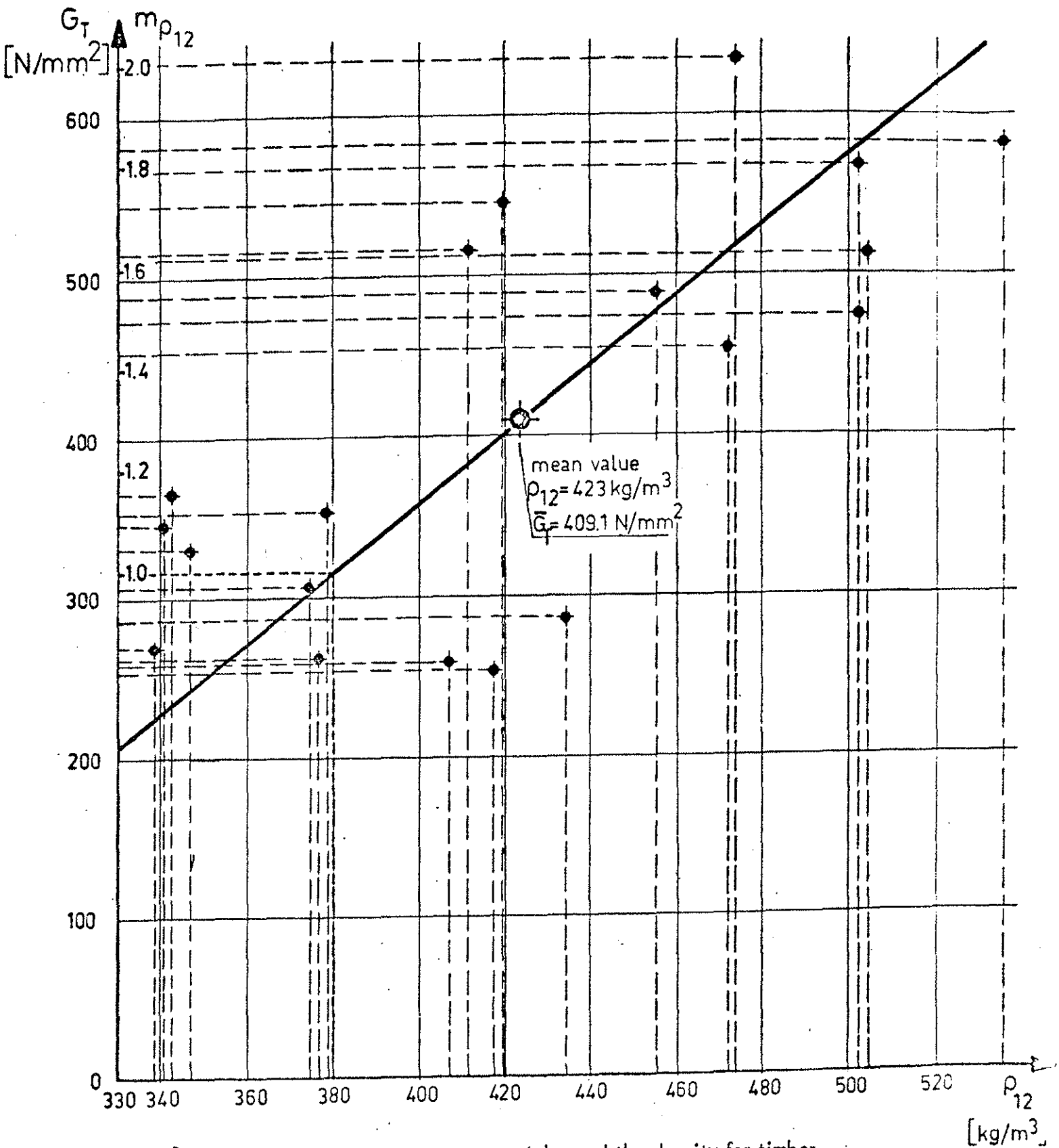

figure 7: relation between the torsion modulus and the density for timber

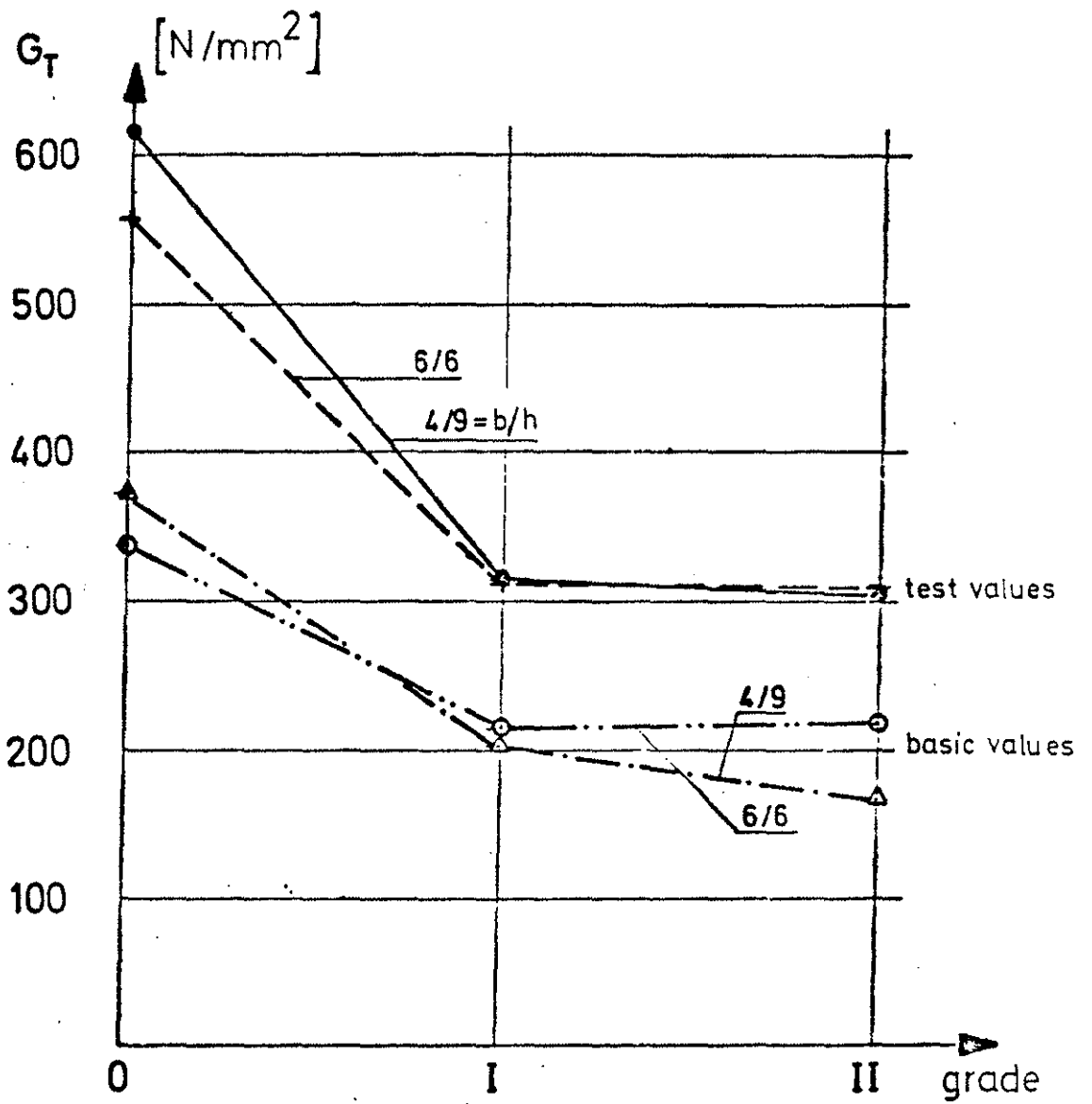

figure 8 : relation between the torsion modulus and the grade referenced to the German standard DIN 4074 for timber

CIB-W18/7-7-1

INTERNATIONAL COUNCIL FOR BUILDING RESEARCH STUDIES AND DOCUMENTATION

WORKING COMMISSION W18 - TIMBER STRUCTURES

TESTING OF INTEGRAL NAIL PLATES AS TIMBER JOINTS

by

K MOHLER

Universität Karlsruhe (TH)

Karlsruhe

STOCKHOLM, SWEDEN - FEBRUARY/MARCH 1977

TESTING PUNCHED METAL PLATES AS TIMBER CONNECTORS:
GUIDE-LINES (Code of Practice) FOR TESTING

1 GENERAL

These guide-lines are intended to promote uniform methods of testing punched metal plates as connectors for load-bearing timber structural members.

2 CONCEPT AND TREATMENT

Punched metal plates as understood in these guide-lines normally comprise steel plates having a thickness at least 1 mm, corrosion-proofed on both sides, with nail- or spike-type parts punched out towards one side and bent up perpendicular to the plane of the plate.

The punched metal plates serve as splice-plates or gusset-plates for connecting two or more timbers of equal thickness. For this purpose they are pressed, by means of a special platen or roller press, into the surface of the timber to a depth such that the plate is lying flush and the punched-out parts are embedded in the timber over their full length.

3 THE PURPOSE OF THE TESTS

The purpose of the tests is to provide information for the design, construction and inspection of the timber connections. The following are the design data required:

- a) Permissible force F_f in N/mm^2 (kp/cm^2) at the contact surface area between punched metal plate and timber surface, as a function of the angle α (angle between the direction of the force and of the plate) and of the angle β (angle between the direction of the force and of the grain); or
- b) Permissible force F_A in $N(kp)$ per punching as a function of angles α and β (especially with spike-type punchings);
- c) Permissible force F_Z in N/mm (kp/cm) of plate width (without subtracting the apertures), under tensile loads with $\alpha = 0^\circ$ and $\alpha = 90^\circ$ for $\beta = 0^\circ$;
- d) Permissible force F_S in N/mm (kp/cm) of plate width (without subtracting the apertures), under shear load, as a function of angle α .

4 PRELIMINARIES TO TESTING

4.1 Choice of plate sizes for testing;

Two or three plate sizes are to be selected from the production range of the manufacturer in such a way that the required design values for all plate sizes can be obtained with adequate reliability by interpolation. When the size of the plate does not affect the load-bearing capacity, it is sufficient to test one size of plate.

4.2 Data required before start of testing:

Data regarding corrosion-proofing, elongation limits and tensile strength of the basic material (steel plate) is to be provided by the manufacturer. Where the manufacturer has no special requirements (eg special performance), the following conditions are laid down:

Species of timber: spruce, planed (if required other species and sawn surfaces are to be comparatively tested)

Thickness of timber: 2 x length of punchings + \approx 5 mm, but not less than 35 mm

Moisture content,

at production: \approx 22%

at testing : $18 \pm 2\%$

Compressive strength: $36 \pm 2 \text{ N/mm}^2$

(at U = 15%) ($360 \pm 20 \text{ kp/cm}^2$)

For wood with compressive strength σ_{D11} above 38 N/mm^2 (380 kp/cm^2) the test results (if failure occurs in the timber) must be multiplied by the factor $\alpha = 36/\sigma_{D11}$;

The test pieces are to be assembled at the testing laboratory or at the factory under the supervision of an officer of the testing laboratory.

A cutting plan showing how the timber test-pieces were cut from the plank, must be recorded to ensure comparability of the test results.

5 THE TESTS

5.1 Material characteristics:

5.1.1 Material characteristics of the metal plate: Tensile strength, yield point, elongation and hardness of the steel plate before punching, and corrosion-proofing are to be determined in accordance with appropriate test specifications.

5.1.2 Material characteristics of the punched metal plates: The bending behaviour of the punched nails (bending-back test) by repeated bending up and down up to 45° , (beginning with bending towards the holes) must be investigated. The number of bendings until fracture should be recorded. Similar tests should be carried out on plates with spike-type punchings.

5.2 Testing of timber connectors:

5.2.1 Static tests on individual test pieces: The probable maximum load F_{\max} is to be determined by preliminary tests.

Loading is effected continuously up to $0.4 F_{\max}$ with a loading rate of $0.2 F_{\max}/\text{min}$ or a testing machine cross-head motion of $1 \text{ mm}/\text{min}$ to $1.5 \text{ mm}/\text{min}$. After half a minute at $0.4 F_{\max}$ the load is reduced to $0.1 F_{\max}$, and after a further half-minute continuous loading is resumed at the above loading rate up to $0.7 F_{\max}$. This is followed by loading to maximum load with a higher rate of deformation (about $4 \text{ mm}/\text{min}$). At each load increment or decrement deformations should be measured without disturbing the continuity of the loading procedure. If possible the load/slip curve should be drawn automatically. At least 5 similar test pieces are to be tested for each type of test.

Each specimen shall be made with two punched metal plate fasteners used as splice plates, one on each side of the specimen and symmetrically positioned on the two members which shall be separated by a gap of 1 mm . The edges of the testing machine grips shall be not less than 200 mm from the ends of the plates for tests of tension parallel or perpendicular to the grain.

5.2.1.1 Tensile tests:

a) Arrangement of the test piece for failure in lateral resistance of nails or teeth.

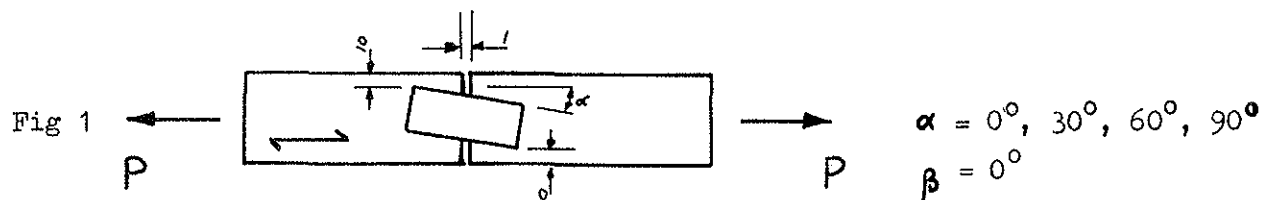

It is generally sufficient to test the longest plate for which failure is to be expected at the nails or teeth rather than in the plate.

b) Arrangement of the test piece for failure of the metal plate

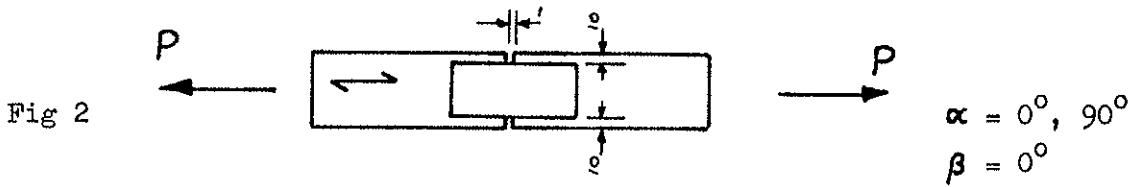

The length of plate must be chosen on the basis of the test results of 5.2.1.a so that failure occurs in the plate.

5.2.1.2 Tensile tests perpendicular to the grain:
Arrangement of the test piece

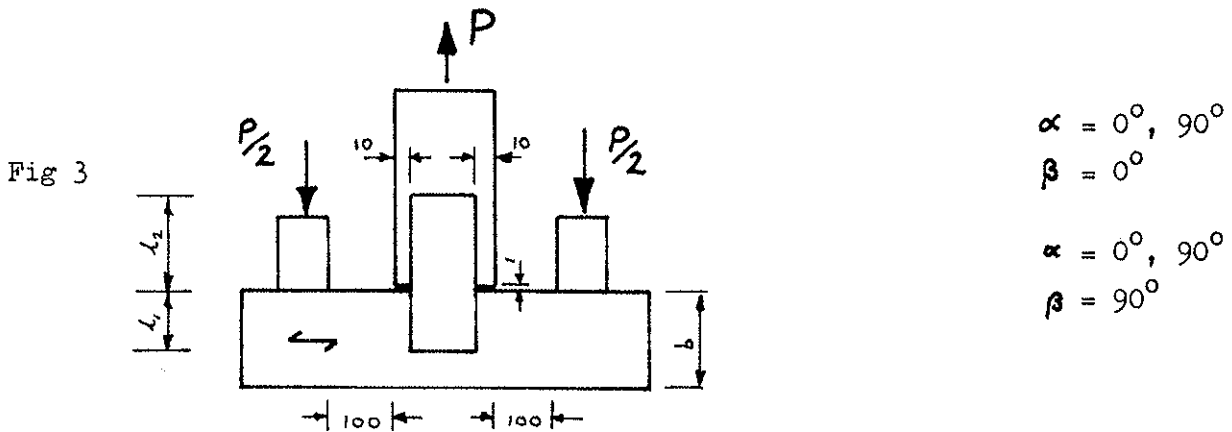

The plates should be arranged to ensure that failure of the nails occurs on the parts of the plate on the cross-timber ($l_1 \leq l_2$). Tests shall be made with length $l_1 > b/2$ and $l_1 < b/2$.

5.2.1.3 Compression tests: In compressive members and joints of compression members it can be assumed that the force is transmitted directly by contact of the connected timber; for this reason compression tests are usually unnecessary.

5.2.1.4 Shear tests: Only shear tests and tensile shear tests have to be made since compression shear joints are not allowed.

Arrangement of the test pieces

Fig 4

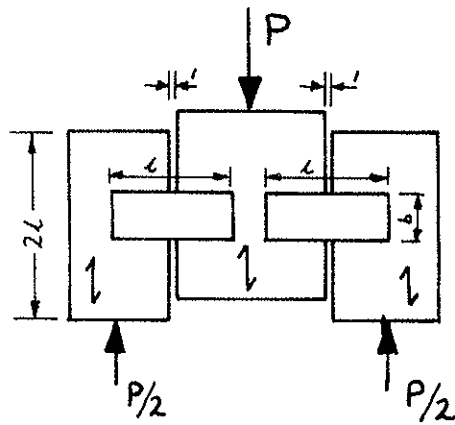

$$\alpha = 90^\circ$$

$$\beta = 0^\circ$$

$$l/b = 2$$

Fig 5

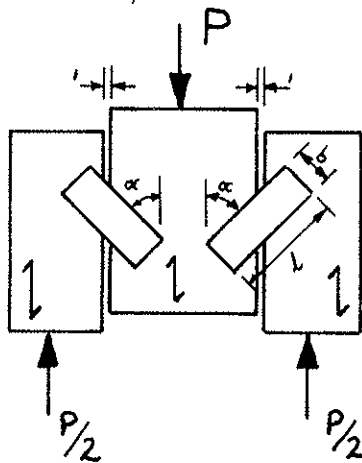

$$\alpha = 15^\circ, 30^\circ, 45^\circ, 60^\circ$$

$$\beta = 0^\circ$$

$$l/b \leq 2$$

Fig 6

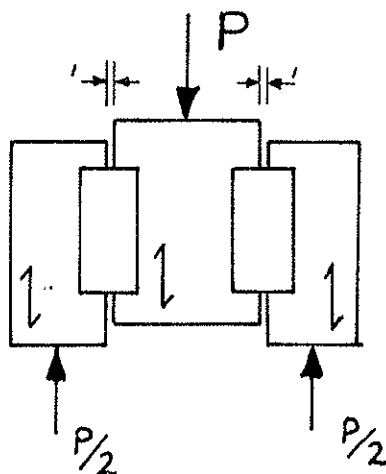

$$\alpha = 0^\circ$$

$$\beta = 0^\circ$$

$$l/b \geq 2^+$$

*In each case with variation of the ratio l/b by tests on additional plate sizes.

5.2.2 Dynamic tests (continuous oscillation tests) with individual test pieces:

Tests by special request, eg when using the plates for crane or bridge building. The test specimens for cyclic tests are of the same form as those of 5.2.1.

Maximum and minimum loads are to be fixed and the number of load alternations before fracture are to be recorded. Displacements in relation to the load changes shall be recorded. In certain cases a Wöhler curve must be established.

5.2.3 Long-term (endurance) tests with individual test-pieces: Tests by special request, eg for use in structural members with a high permanent component of load. Test piece in accordance with 5.2.1.

Maximum load should be between 50 per cent and 70 per cent of the static breaking load.

5.2.4 Static tests with structural members: Tests on special constructions, eg composite beams with non-standard plate sizes.

CIB-W18/7-7-2

INTERNATIONAL COUNCIL FOR BUILDING RESEARCH STUDIES AND DOCUMENTATION
WORKING COMMISSION W18 - TIMBER STRUCTURES

LONG DURATION TESTS ON TIMBER JOINTS

by

J KUIPERS

Technische Hogeschool

Delft

STOCKHOLM, SWEDEN - FEBRUARY/MARCH 1977

Long-duration tests on timber joints.

Summary

An interim report is presented about long-duration tests on joints with split-ring and toothed plates and on nailed joints. The program started in 1962 and includes the results of 79 test specimens, loaded to 60 to 90% of the mean ultimate load as found from 60 matched specimens tested according to a standard (short duration) procedure.

In comparison with the expectation, based on available information about the effect of long-duration of load on small clear wood specimens, the joints seem to show less time-effect. This is especially the case with nailed joints.

The creep data of the joints did not show a definite "warning point" announcing a near failure.

Long-duration tests on timber joints.

1. Introduction

After a relatively long period of preparations and preliminary research, [1] an investigation was started in 1962 to study the long-duration strength of three types of timber joints. Until now 79 joints have been incorporated in the program, while in addition to this some other joints were tested.

The program has not been finished yet; it is hoped that more information can be produced in the future. This information is very strongly needed to reach a sufficient insight into the behaviour of timber structures under load. This need exists as well in the field of wood as a material as of the joints needed to make building structures with it. Already during the period of preliminary research this was realised and in his paper [1] Vermeyden develops a broad and scientific scope of subjects which are of interest to study. For shortness' sake this program is not repeated here but only the results of the tests which were carried out as yet in a more restricted investigation are given and shortly commented.

The object of this restricted investigation is:

"to collect data about the long-duration strength of joints with mechanical connectors and to investigate if the effect of long term loads on such joints is comparable with the effect on wood;

to get information about the creep behaviour of joints, and especially if there could be found in one way or another an indication that failure of the joint under load had to be expected within a near future."

2. Description of the investigation

2.1. Method of testing

During the development of the investigation it was realised that several methods could be used to study the long-term behaviour of joints under load. Although there existed a strong interest in the deformations of such joints too, especially under service conditions, it was decided that first of all it was the long-duration-strength that had to be determined. This long-duration-strength can be estimated in different ways, for instance according to methods a, b and c of fig. 1. The "active" loading procedure a) seems to be a manpower and time consuming method, even if the constant rate of loading is substituted by a stepwise loading procedure.

In the investigation described here, the method b) was chosen, be it that only the higher load levels were introduced in the program. The load levels p were determined on the basis of standard (short duration) tests [2]. This method b) is also very time-consuming but it has the advantage that most of the available data about the long-duration strength of wood has been based on this method too. The difficulty of this procedure is of course that the standard strength F_u of the individual test specimen cannot be determined. It is therefore only possible to load such joints to a certain percentage of the standard strength of other test specimens. The resulting time to failure will be influenced therefore by the accuracy with which each individual test specimen would have approached the predicted standard strength.

Another approach is given in fig. 1 c, where test specimens are loaded to a certain degree (e.g. about at or somewhat higher than the working load) during a predetermined time. After that time they can be tested according to the standard test procedure (short duration). This method gives information

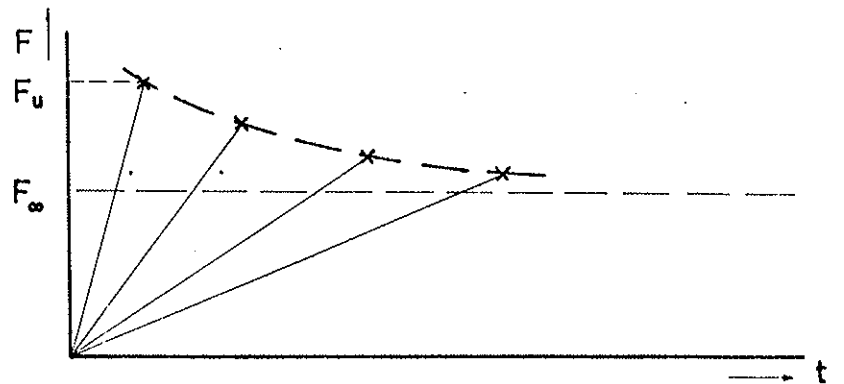

a) active loading with different velocities

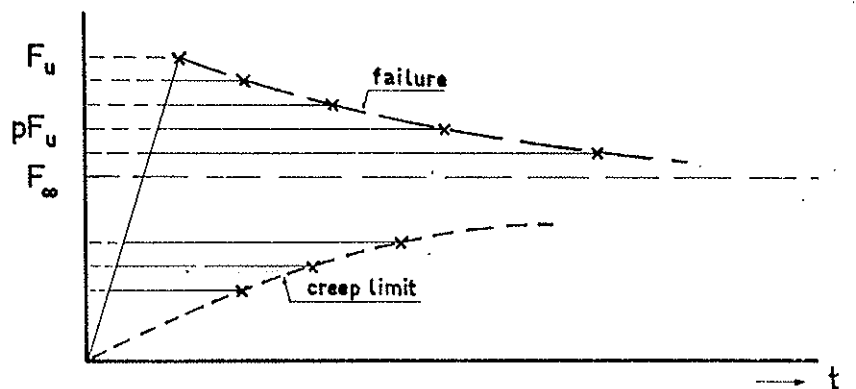

b) active loading followed by constant load at load levels p . At lower loads than F_∞ it is supposed that a creep limit exists after a certain time t .

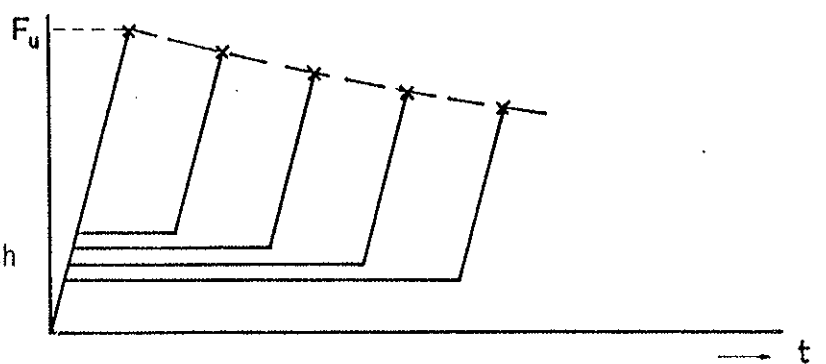

c) standard strength test after preloading during a certain time to one or to a few "allowable" levels.

Fig. 1.

about the eventually occurring strength reduction caused by the preload. Also - if sufficient tests were carried out - the statistical characteristics of that remaining strength become available as well as data about creep figures at normal working conditions. Such tests have been incorporated in the total program of the investigation but they have not yet been started. In this connection very briefly a result may be mentioned of long duration tests on two similar nailed trusses with a span of 10 m. They were exposed to static loads as in the table. After a total test period of more than 3 years one of the trusses collapsed under 2,2 x design load. The other truss was then tested in a standard (short duration) test. In both cases failure occurred in a nailed joint of the lower chord. The short duration test gave failure at 2,9 times design load. [3]

load	
x design load	duration
1,0	2½ year
1,5	2 month
2,0	3 month
2,2	2 month

Madsen [4] also reports that he finds not a loss in strength due to preloading.

2.2. Matching

In order to decrease the unfavourable effects of the variation of strength as mentioned before, it was decided that some matching technique should be used. Because in the program three different treatments are incorporated (standard test, long-duration test and loss-of-strength test) the test specimens for each set of treatments are to be made of the same pieces of wood (cf.2.4).

A special investigation [HD 5] showed that differences in the behaviour of joints made of pieces of wood which were "neighbours" in the lumber they were cut from, were not significant smaller than the differences between joints just made from the same pieces of lumber.

In fig. 4 the cutting scheme of the lumber is shown. Each 3-member joint was made of two pieces of wood: M and Z, "Neighbouring" test joints were:

1-2	9-10	16-17
2-3	(10-11)	17-18
3-4	11-12	18-19
4-5	12-13	19-20
5-6	13-14	
(6-7)		
7-8		

In fig. 3 the properties of the joints were plotted. It cannot be shown that the differences between "neighbouring" test joints are smaller than between arbitrarily chosen joints made from two planks M and Z.

In an other small series of tests with Bulldog toothed-plate joints 5 times 3 matched specimens were loaded to failure. In this case the members S_l of the three matched specimens were cut from the same plank, and so were the three members M resp. S_r cut of another plank. The loading procedure of two short-duration* test methods differed as is shown in fig.4^a and 4^b.

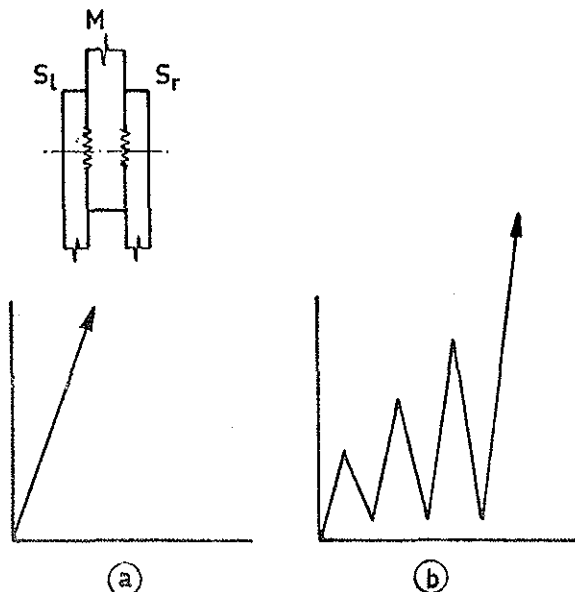

Fig. 4.

* The third specimen in each series was a preliminary long-duration test.

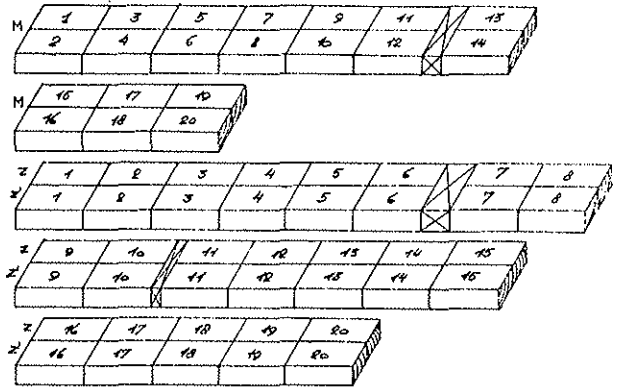

Fig. 2.

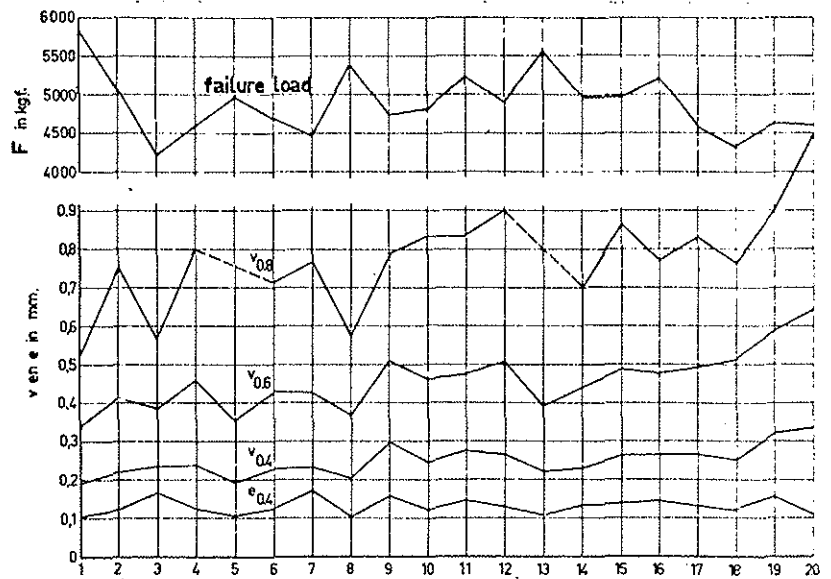

Fig. 3.

The results of the short duration tests a and b have been given in table 2.

A statistical analyses learned that it is very probable that the matching-procedure has influenced the results. This is visualised in fig. 9. It can be demonstrated too that the different loading procedures must have influenced the results. It was not expected however that the slower method b should give higher test results.

The results of these tests have given some indication that matching of test specimens will have a positive effect on the accuracy of the long-duration program. Therefore such a matching-

procedure has been followed during the whole investigation (cf.2.4). The loads for the long-duration-tests have been based upon the mean

Table 2. Ultimate load of matched toothed-plate-joints (N)

N ^o	series	
	a	b
1	39150	41850
2	41450	43800
3	39250	40500
4	37150	38500
5	35800	37400

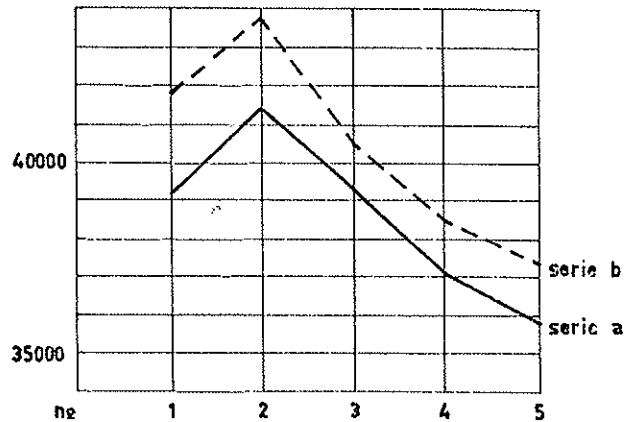

Fig. 5.

short-duration strength values; the possible effect of matching is neglected in this way; it remains possible however to study this effect afterwards (cf.4.2).

2.3. Loading procedure; circumstances during the tests, etc.

All test specimens have been loaded by dead loading. This load was put in action by using an oil jack, with a hand pump, with which it was tried to load in a predetermined time with constant speed. The loading time was 20 to 85 sec, with 40 to 50 sec as a mean value.

The specimens with a loadingpercentage $p = \frac{\text{constant load}}{\text{mean strength}} > 0,80$ and partly those with $p = 0,80$ were loaded separately. The specimens with $p = 0,60$ and $p = 0,65$ were loaded in series of four and the other specimens — $p = 0,70$ and $0,75$ — in series of two.

This way of execution of the tests was chosen in order to reduce the amount of loading material as well as of space. The risk that failure of one of the specimens in a series would influence the other ones - unloading by a shock and re-loading - had to be accepted. It was not possible in such cases to measure the amount of elastic recovery in the joint as a result of the unloading. Creep measurements are in that case not continually. Unless the influence of failure of one test specimen on the others was shown very clearly (sometimes failure of the re-loaded specimens occurred within a few minutes to some hours) no influence is supposed. This leads to a conservative estimation of the long-duration strength.

The test specimens were attached to a crane-beam; the vibrations of the moving crane along this beam was damped by springs. Some influence however

must have been experienced by the tests.

The tests have been carried out in an unconditioned room. Very roughly the temperature varies between 18 and 23 °C, with tops of 15 to 27 °C; the relative moisture content of the air varies between 45 to 75%, with short periods of one day to 40 resp 80%. Here also an effect on the behaviour of the tests existed.

The somewhat primitive circumstances will of course have affected the results of the tests. Especially where it was tried to compare the results of these tests on joints with those of clear wood the complications mentioned above are a disadvantage. Although consideration was given to the proposal to postpone the investigation until better conditions should become available, this was not followed. One reason was that this postponement would last for at least 10 years. It was also considered that tests carried out under conditions as described have more relationship with the real circumstances of structures. In this respect doubts upon the actual data as to be too sophisticated are not justified anymore.

At the time of fabrication of the test-joints the timber had a moisture content of about 20% (it was conditioned in a climate of ca 20 °C.; 85% Rel. Hum.). The joints were then stored in a climate of 20 °C and ca 40% RH, where the wood dried to about 10%, which is the mean equilibrium moisture content of European Softwood in the laboratory hall during the winter season. The bolts in splitting and toothed plate connections were tightened at the fabrication and remained untightened after the drying and shrinking had taken place. It may be expected that they had the maximum gap between the members at the time of loading. Because of the realistic conditioning of wood and joints it may also be expected that these gaps will be comparable to those in practice.

2.4. Test specimens.

The test program includes three types of joints:

- 1) joints with one TECO splitting unit ϕ 73 mm with bolt ϕ $\frac{1}{2}$ " ; members (39 x 95 mm) + 2 x (27 x 95 mm); end distance 85 mm;
- 2) joints with one BULLDOG-connector unit ϕ 75 mm with bolt ϕ $\frac{1}{2}$ " ; members (33 x 95 mm) + 2 x (18 x 95 mm); end distance 75 mm;
- 3) joints with 60 nails (45 x 2,8 mm); members (58 x 95 mm) + 2 x (18 x 95 mm); end distance 34 mm.

More detailed information about these joints have been given in fig. 6. They have been designed so because in all cases the expected short-duration-strength is about 40 kN. In all cases minimum-allowable placing conditions

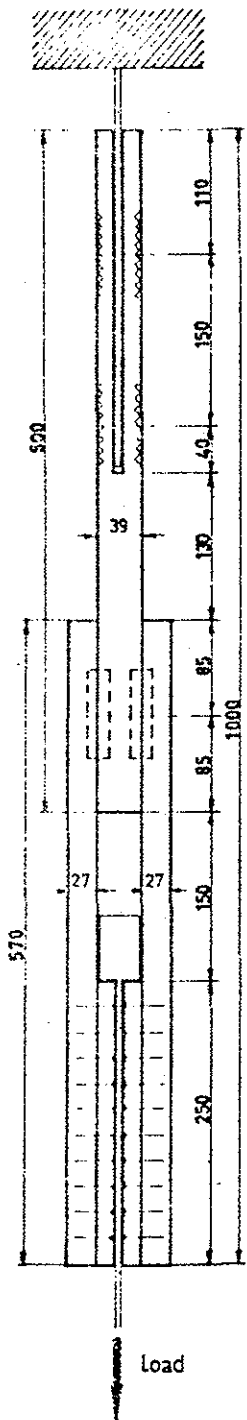

splitring ϕ 73 mm
 $\frac{1}{2}$ " bolt; bolt hole 14 mm
 washers 80.80.7 mm
 width of member 95 mm

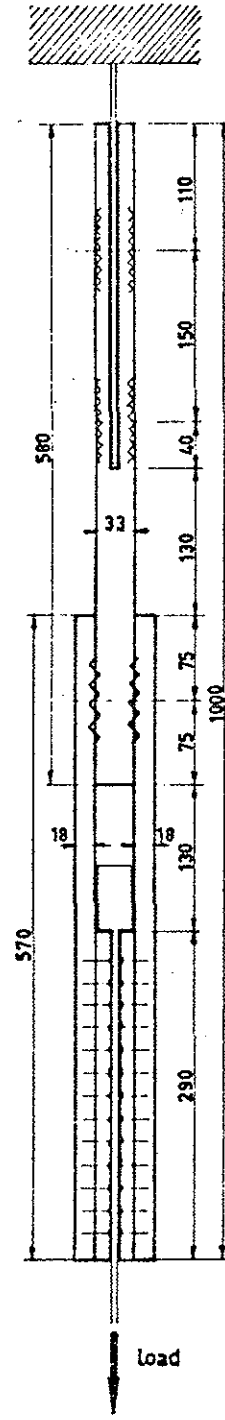

toothed plate ϕ 75 mm
 $\frac{1}{2}$ " bolt; bolt hole 14 mm
 washers 80.80.7 mm
 width of member 95 mm

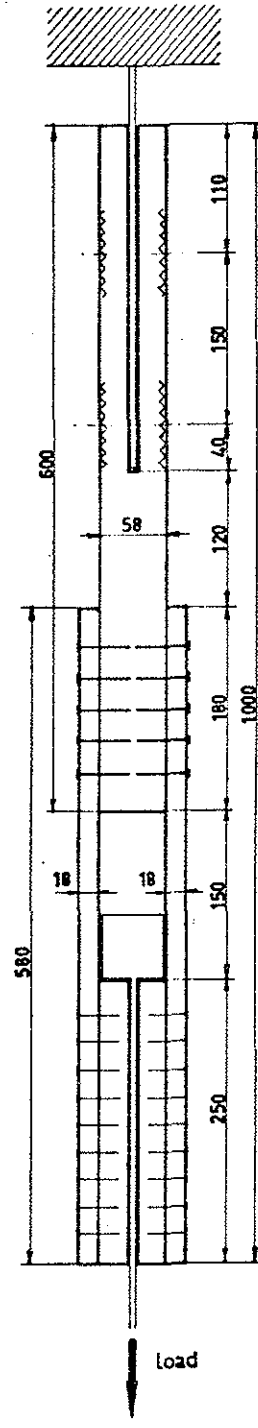

nailing pattern
 wire nails 45 x 28 mm
 $n = 2 \times 5 \times 6 = 60$

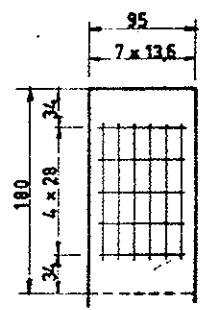

fig. 7

(end and edge distances, etc) were chosen, as well as minimum dimensions of the jointed members.

From each type of joint 100 specimens were made:

- I) 40 specimens for standard tests,
- II) 40 specimens for long-duration tests and
- III) 20 specimens for strength-decreasing tests.¹⁾

The needed amount of timber was bought in lengths, sufficient to make 5 members out of one plank or joist, so 2 members for series I, 2 for series II and 1 for series III. Each set of 5 matched specimens was in this way built up of three planks (two side members and one middle member).

In table 1 the test program has been given as well as the number of tests under consideration now.

Table 1 test program and number of joints tested until 1 January 1977.

		Standard test series I	long-duration tests (series II)							total
			load level p							
			0,90	0,85	0,80	0,75	0,70	0,65	0,60	
program	splitrings	20	8	8	8	4	4	4	4	40
	toothed plates	20	8	8	8	4	4	4	4	40
	nails	20	8	8	8	4	4	4	4	40
loaded	splitrings	20	5	6	5	4	-	6	4	30
	toothed plates	20	5	6	6	4	-	4	4	29
	nails	20	4	4	2	2	-	4	4	20

3. Test results.

3.1. Standard tests; loads at different load-levels p.

In table 2 mean values of the ultimate loads as well as the data about the deformations of the standard tests have been given; the loading procedure has been given in fig. 6.

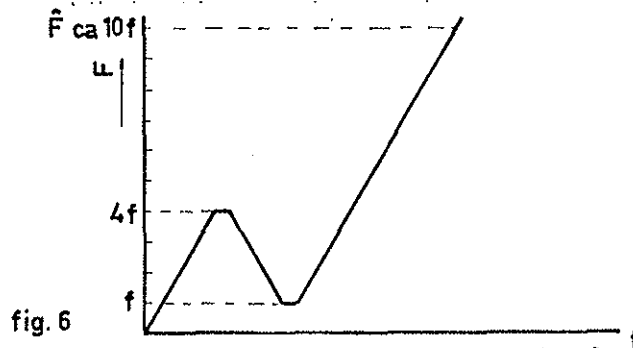

1) These test specimens are available for tests where the remaining strength after a certain duration of load will be determined (cf fig. 1^c). These tests have not yet been started.

Table 2 Mean test results

type of joint		ultimate load (N)	deformations (mm)			
			$e_{0,4}$	$v_{0,4}$	$v_{0,6}$	$v_{0,8}$
split-rings	mean	28820	0,22	0,35	0,57	0,94
	st dev.	4380	0,04	0,05	0,10	0,23
	coëff. var.	0,15	0,19	0,15	0,17	0,24
toothed plates	mean	32160	0,25	1,29	2,30	3,36
	st dev.	2690	0,04	0,21	0,32	0,44
	coëff. var.	0,08	0,16	0,17	0,14	0,13
nails	mean	44970	0,21	0,55	1,10	2,26
	st dev.	1760	0,02	0,05	0,11	0,34
	coëff. var.	0,04	0,08	0,09	0,10	0,15

Compared with the expected ultimate loads the test results of the splitting and the Bulldog joints are surprisingly low. The nailed joints show somewhat higher values than the expected 40000 N.

The deformations of the three types of joints show much difference, only the e-values are about the same. Especially the Bulldog-joints show large deformations at all load levels.

The load levels for the long-duration tests have been determined on the basis of the mean values of table 4. They have been mentioned in table 3.

Table 3 Load Levels (in N.)

type of joint	load level						
	0,90	0,85	0,80	0,75	0,70	0,65	0,60
splitrings	25940	24500	23060	21620	20170	18730	17290
toothed plates	28940	27340	25730	24120	22510	20900	19300
nails	40470	38220	35980	33730	31480	29230	26980

The real strength value of a joint will be different from the mean value. This means that the real load levels of all joints will differ, even if they are loaded to the same value. It is very probable (about 95% probability) that the real joint has an ultimate load between $\hat{F} \pm 2s$ (\hat{F} = mean value; s = standard deviation). This means that also the real load level of a certain joint is not equal to the predetermined level. In table 4 the range of real load levels has been given for the three types of joints.

Table 4. Range of real load levels.

nominal load level	range of real load level		
	split-rings	toothed-plates	nails
0,90	1,29 - 0,69	1,08 - 0,77	0,98 - 0,83
0,85	1,22 - 0,65	1,02 - 0,73	0,92 - 0,79
0,80	1,15 - 0,61	0,96 - 0,69	0,87 - 0,74
0,75	1,08 - 0,58	0,90 - 0,64	0,81 - 0,70
0,70	1,00 - 0,54	0,84 - 0,60	0,76 - 0,65
0,65	0,93 - 0,50	0,78 - 0,56	0,71 - 0,60
0,60	0,86 - 0,46	0,72 - 0,52	0,65 - 0,56

It can also be calculated that there is a probability of about 25% that a split-ring joint has a failure load of 25940 N, which is the 0,90 - load level. So we can expect 25% of the 0,90-level split-ring-joints to fail immediately after loading. Even at the 0,70-level there is a chance of about 4½% that a joint will fail just after loading.

The load levels can also be compared with the allowable loads on the joints. These are (NEN 3852, TGB 1972 Hout):

$$F_{all} = 9600 \text{ N for the split-ring-joints.}$$

$$F_{all} = 8000 \text{ N for the toothed-plate joints}^{*}) \text{ and}$$

$$F_{all} = 12000 \text{ N for the nailed joints.}$$

As said before, the joints were made with minimum allowable dimensions.

In table 5 the amount of overload on the joints at different load levels has been given.

Table 5 Load levels and overload factors.

	load level					
	1,00	0,90	0,80	0,70	0,60	
split-ring-joints $F_{ult} = 28820 \text{ N}$ $F_{all} = 9600 \text{ N}$	3,0	2,7	2,4	2,1	1,8	$\times F_{all}$
toothed plate $F_{ult} = 32160 \text{ N}$ $F_{all} = 8000 \text{ N}$ $(F_{all} = 11600 \text{ N})^{*}$	4,0 * (2,8)	3,6 (2,5)	3,2 (2,2)	2,8 (2,2)	2,4 (1,9)	$\times F_{all}$
nails $F_{ult} = 44970 \text{ N}$ $F_{all} = 12000 \text{ N}$	3,74	3,37	3,0	2,62	2,24	$\times F_{all}$

*)The standard specifications for these joints were adopted after the start of the investigation. According to these the end distance of 75 mm is too small for the bolt so its effect has to be ignored. If the minimum allowed end distance of $7d = 89 \text{ mm}$ was chosen the allowable load would have been 11600 N. The overload factors based on this value have been presented in table 5 between ()

3.2. Duration of load to failure.

All 30 split-ring joints in the program have failed; 28 of the 29 toothed-plate joints failed too; from the 20 nailed joints 10 failed until now (see table 6) .

Table 6. Number of joints still under load on 1 Jan. 1977

	load level p							total
	0,90	0,85	0,80	0,75	0,70	0,65	0,60	
split-rings	-	-	-	-	-	-	-	-
toothed plates	-	-	-	-	-	1	-	1
nails	-	-	1	1	-	4	4	10

In table 7 the time-to-failure has been given for all joints seperately.

Table 7. Time-to-failure in hours of the failed specimens

	load level p					
	0,90	0,85	0,80	0,75	0,65	0,60
split-rings	2640	1,7	≥2390	≥3056	5410	27872
	8,6	1610	0	3048	3771	19960
	93	35	≥0,8	≥368	7205	63715
	0,02	3,2	46	367	4170	11134
	63	358	0,9		≥3772	
		0,03		≥3777		
toothed plates	581	191	0	13256	20059	86250
	0	2454	4207	508	37598	47783
	621	4363	584	198	14749	22500
	0	≥24516 ¹⁾	624	20	>103693	
	517	5019	169			
		1,8	1452			
nails	8629	0,3	1525	104222	>122976	>122976
	3548	6842	>117630	>104222	> "	> "
	25617	6794			> "	> "
	44689	68112			> "	> "

In this table 7 in several cases the time to failure is quoted as \geq a certain value. In most cases this means that failure occurred very soon after the re-loading of the joint in a series (cf 2.3) where another joint had collapsed and an unfavourable effect on its "neighbours" may be supposed. The sign $>$ means that failure not occurred after the time quoted.

¹⁾ failure occurred outside joint.

Table 8. shows the log-t values of the joints

Table 8. Time-to-failure (in log t) of the failed specimens.

	load level p					
	0,90	0,85	0,80	0,75	0,65	0,60
split-rings	3,4216	0,2304	≥3,3784	≥3,4852	3,7332	4,4452
	0,9345	3,2068	0	3,4840	3,5765	4,3002
	1,9685	1,5462	≥-0,1079	≥2,5658	3,8576	4,8042
	-1,6990	0,5011	1,6656	2,5647	3,6201	4,0467
	1,8007	2,5539	-0,0605		≥3,5766	
		-1,5229		≥3,5771		
toothed-plates	2,7642	2,2817	-2,5	4,1224	4,3023	4,9358
	0	3,3899	3,6240	2,7059	4,5752	4,6793
	2,7931	3,6398	2,7664	2,2956	4,1688	4,3522
	-3	≥4,3894	2,7952	1,3054	>5,0157	3,1446
	2,7135	3,7006	2,2279			
	0,2601	3,1620				
nails	3,9360	-0,4815	3,1833	5,0180	>5,0808	>5,0808
	3,5500	3,8352	>5,0705	>5,0180	> "	> "
	4,4085	3,8321			> "	> "
	4,6502	4,8332			> "	> "

3.3 Deformations

In a series of graphs the deformations of the different joints have been given as a function of log-t. In table 9 the deformations at certain discrete values of t have been given, as well as the maximum deformations "just before" failure. Because the deformations were not always continuously measured, the time between the last measurement and failure is somewhat different however. The time $t = 0$ is taken as the moment just after the load has reached its predetermined value. The deformation at that very moment was sometimes difficult to measure; as a starting point for measuring creep the initial deformation was considered to be the deformation at 10 min. (= 0,16 hrs) after the wanted load was acting.

Table 9. Deformations of joints at different times.

t hours	Load level p =																										
	0,60			0,65			0,75			0,80			0,85			0,90											
0	0,73			0,87			0,99			0,75			1,03 0,73			0,99											
0,16	0,67	0,76	0,62	0,62	0,81	0,89	1,06	0,90	0,68	1,10	0,85	0,63	1,48	1,17	0,85	1,13	1,16	1,53									
24	0,74	1,05	0,70	0,69	0,96	1,07	1,23	1,06	1,11	1,25	1,05	1,44	1,68	1,26	1,25	1,29	1,32	1,75									
48	0,80	1,10	0,72	0,74	0,99	1,12	1,27	1,10	1,15	1,29	1,16	1,53	1,74	1,32	1,34	1,41	1,39	1,81									
100	0,82	1,16	0,74	0,76	1,06	1,21	1,32	1,19	1,19	1,34	1,20	1,57	1,80	1,35		1,50	1,42	1,90									
240	0,92	1,20	0,80	0,83	1,20	1,30	1,48	1,36	1,28	1,47	1,32	1,72	1,93	1,44	1,86	1,61		2,03									
split- ring	480	0,97	1,23	0,85	0,89	1,25	1,40	1,53	1,47	1,39	1,59	1,37	1,81	1,52				2,34									
	720	1,02	1,25	0,88	0,93	1,32	1,45	1,58	1,56	1,47	1,66	1,43	1,87	1,57				2,50									
	1000	1,06	1,34	0,90	0,96	1,34	1,51	1,60	1,61	1,77	1,77	1,44	1,93	1,58				2,67									
	2400	1,30	1,77	1,04	1,15	1,59	1,95	1,85	1,87	1,96	1,96	1,73	2,47					2,92									
	4800	1,66	2,17	1,22	1,37	1,85				2,13																	
	10000	2,19	2,61	1,42	2,00																						
	24000	2,67	2,59																								
	48000		3,47																								
max.	2,9	4,1	4,3	2,2	2,5	2,6	2,2	2,2	2,4	2,6	1,9	2,5	2,1	1,9	1,3	2,5	1,9	3,0									
0																2,76											
0,16	1,79	1,83	1,97	2,63	2,33	2,81	2,56	1,97			2,98	2,99	3,61	2,98	2,83	2,89	2,75	2,94	3,17	3,90	2,44	3,68	3,05	3,04	3,11	3,97	
24	2,06	2,10	2,17	2,97	2,57	3,11	3,13	2,17			3,24	3,37	4,50	3,76	4,00	2,98	7,88	3,45	3,87	4,15	3,12	4,25	3,79	4,08	4,40	6,90	
48	2,15	2,18	2,24	3,06	2,62	3,14	3,19	2,20			3,37	3,54	4,68	3,88	5,16	3,05	8,25	3,59	4,37	4,20	3,21	4,33	3,91	4,20	6,13	7,11	
100	2,21	2,25	2,28	3,17	2,70	3,24	3,28	2,28			3,47	3,69	4,88	3,95	5,29	3,11	8,99	3,82	4,89	4,26	3,30	4,42		4,37	6,49	7,50	
toothed plates	240	2,34	2,41	2,37	3,39	2,78	3,40	3,51	2,39		3,68	4,09		4,19	5,64	3,28		4,35		4,33	3,45	4,64	5,06	4,75	6,99	13,00	
	480	2,41	2,48	2,44	3,51	2,86	3,48	3,62	2,45		3,80	4,28		4,47	10,12	3,37		4,60		4,49	3,58	4,92	6,49	5,36	7,38	13,74	
	720	2,50	2,54	2,50	3,62	2,95	3,55	3,72	2,53		4,02			4,88				4,80		4,55	3,97	5,05	6,90				
	1000	2,59	2,57	2,56	3,76	3,03	3,63	3,83	2,60		4,10			5,17				5,00		4,63	5,22	5,57	7,19				
	2400	2,92	2,92	2,82		3,35	3,88	4,15	3,19		4,40			7,99						4,89	7,76	7,85	8,87				
	4800	3,17	3,15	3,17		3,66	4,21	4,57	3,51		5,85											8,98	13,74				
	10000	3,58	3,45	3,45		4,10	4,71	5,11	3,92		7,68											10,91					
	24000	4,28	4,30				6,02		4,70													13,76					
	48000	5,64							5,71																		
	72000	10,27							6,35																		
	100000								6,83																		
max.	16,2	12,0	14,0	4,0	4,6	7,1	5,8				9,0	4,3	5,2	13,0	16,3	3,5	11,5	5,4	6,6	5,0	9,4	13,8	15,3	5,5	7,4	13,9	
0	1,44			2,03			2,00			3,95 1,51			2,26														
0,16	1,71	1,78	1,42	1,68	2,27	2,61	2,04	1,96			2,49	2,72		5,33	2,44				2,56	4,40	3,05			4,20	3,76	1,69	3,41
24	2,14	2,02	1,80	2,16	2,84	3,16	2,67	2,47			3,23	3,68		6,83	3,24				4,46	5,35	3,55			4,95	4,56	2,47	4,08
48	2,27	2,16	1,90	2,31	2,94	3,28	2,74	2,55			3,49	3,95		7,13	3,44				4,78	5,60	3,65			5,15	4,81	2,54	4,26
100	2,38	2,30	1,98	2,43	3,10	3,35	3,00	2,67			3,69	4,18		7,48	3,65				5,04	5,68	3,77			5,46	4,96	2,89	4,39
240	2,60	2,50	2,17	2,70	3,41	3,50	3,46	2,96			4,18	4,70		7,93	3,90				5,40	5,86	3,95			6,80	5,20	3,40	4,48
480	2,71	2,75	2,26	2,82	3,59	3,73	3,69	3,08			4,45	4,97		8,64	4,32				5,82	6,08	4,10			7,17	5,55	3,74	4,85
720	2,83	2,88	2,38	2,99	3,81	3,92	4,02	3,32			4,80	5,33		9,39	4,40				6,02	6,15	4,19			7,32	5,74	3,86	5,00
nails	1000	2,91	2,97	2,45	3,08	3,94	4,05	4,23	3,39		4,98	5,52		9,82	4,52				6,35	6,36	4,33			7,47	5,98	4,07	5,11
	2400	3,10	3,16	2,61	3,23	4,23	4,24	4,49	3,56		5,32	5,86			5,59				8,15	6,81	4,61			8,12	7,11	4,64	5,59
	4800	3,34	3,33	2,79	3,38	4,55	4,49	4,76	3,76		5,60	6,22			6,22				13,48	7,29	5,59			8,67		5,17	7,66
	10000	4,00	3,96	3,30	4,01	5,52	5,29	5,80	4,38		6,68	7,40			6,71						7,82					8,57	9,16
	24000	4,57	4,44	3,74	4,55	6,46	6,07	6,62	4,98		7,71	8,72			7,96						9,70					12,17	12,33
	48000	5,30	5,10	4,33	5,26	7,77	7,09	7,74	5,88		9,08	10,74			10,15												
	72000	5,73	5,53	4,61	5,64	8,77	7,83	8,54	6,47		10,21	12,88			12,15												
	100000	6,08	5,76	4,76	5,87	9,67	8,38	9,21	6,94		11,34	15,59			13,68												
max.										11,4			11,8						18,8	13,4				21,8	14,9	18,4	22,3

Values of $C = \frac{\text{creep deformation}}{\text{initial deformation}}$ have been given in table 10.

Table 10. Mean Values of $C = \frac{\text{creep deformation}}{\text{initial deformation}}$

		t hrs	load level					
			0,60	0,65	0,75	0,80	0,85	0,90
split rings	init.def.(mm)	0,16	0,7	0,9	1,0	1,0	1,2	1,5
	C	10^2	0,3	0,3	0,5	0,4	0,3	0,3
		10^3	0,6	0,8	0,7	0,6	1,0	0,8
		10^4	2,0					
toothed plates	init.def.(mm)	0,16	2,1	2,4	3,1	2,9	3,3	3,4
	C	10^2	0,2	0,2	0,3	0,4	0,3	0,8
		10^3	0,4	0,4			0,7	
		10^4	0,7	0,9				
nails	init.def.(mm)	0,16	1,7	2,2	2,6	3,9	3,3	3,3
	C	10^2	0,3	0,4	0,5	0,4	0,4	0,3
		10^3	0,7	0,8	1,0	0,9	0,7	0,7
		10^4	1,2	1,4	1,7			1,7
		10^5	2,3	2,9	4,2			

4. Discussion

4.1. Strength of standard-test-specimens.

As was mentioned before, the standard tests of the split-ring and the toothed-plate joints showed lower values than was expected on the basis of foregoing tests.

The mean specific gravity of the members was
 0,39 for the split-ring-joints,
 0,40 for the toothed-plate-joints and
 0,42 for the nailed joints.

These differences cannot explain the differences between the expected ultimate load of ca. 40000 N and the mean test values of 28820 N, 32160 N and 44970 N respectively; another explanation could not be found too. The deformation of the split-ring-joints can be compared with results of older tests, which were tested in a somewhat other way. Probably the joints in this new investigation show about the same deformations as the earlier ones.

The same seems to be true for the toothed-plate joints; for the nailed joints earlier tests showed somewhat higher values of the deformations.

The failure of the specimens occurred as normal:

The split-ring-joints showed shear of the core together with shearing and splitting of the members at the loaded ends;

the toothed-plate-joints showed scratching or dragging of the triangular teeth through the wood, bending of those teeth, and shearing under the bolt at the loaded ends of the members;

the nailed joints showed always splitting of the members, together with the occurrence of plastic hinges in the nails.

There is a feeling that the long-duration test specimens are more broken into pieces than the standard tested specimens, but this may be caused by the fact that the dead load remains unchanged during failure, so the joint is then totally pulled apart.

4.2. Duration of load to failure.

In fig 8 to 10 the results of the three types of joints with respect to the time to failure have been given.

There also a "linearised" Madison curve has been given, together with a shaded area where 90% of the test results must be expected if the hypothesis is true that joints follow the same law as the (clear,small) tests in bending.

As could be expected this range is rather broad for the split-ring-joints, smaller for the Bulldog joints and narrow for the nailed joints; this according to their respective variation in the failure strength (standard test).

Only one of the split-ring-joints shows a load-duration outside the lower expectation, although it may be said that most test results are on the "safe side" of the expectation. There is also a tendency that the results at lower load levels show less variation in time and are near the expectation.

The Bulldog joints are more on the safe side and 10 of the 27 joints are even outside the 90% area. This occurrence however disappears at the lower load levels.

The nailed joints are all outside the expectation-area and show definitely much longer life-times than could be expected on the basis of the Madison line. This is even the case with the test specimens of level 0,60, although continuation of the tests during the next years must confirm this trend.

4.3. The possible effect of matching.

Until now there are some matched specimens incorporated in the investigation.

From planks 8,15,18 and 20 short duration strength as well as times to failure under long-duration load are available. In table 11 data about these matched specimens have been given. If the matched long-duration specimens are supposed to have the standard strength of their mates,

the load levels can be re-calculated. For the split-ring-joints some effect can be seen in fig. 11, the tendency leads to a somewhat steeper regression line. Not much difference is seen for the toothed-plate and the nailed joints.

Table 11. Adaptation of load level of mean ultimate load to load level of matched specimens.

	standard strength (N)		long duration test				
	20 spec. mean	matched spec.		load (N)	load level based on matched		
		indiv.	mean		20 spec	spec.alone	log-t
split-rings	28820	26900 27200	27050	21620	0,75	0,80	2,5658
		22000 20400	21200	24500	0,85	1,16(!)	0,234 0,5011
		33500 29300	31400	17290 21620	0,60 0,75	0,55 0,69	4,047 3,4840
		33600 29000	31300	17290 18730	0,60 0,65	0,55 0,60	4,3002 3,5765
toothed-plates	32160	30250 36400	33380	27340	0,85	0,82	3,3899
		30500 34100	32300	28940 28940	0,90 0,90	0,89	- 2) -3
		29900 - 1)	29900	19300 24120	0,60 0,75	0,65 0,80	3,1446 2,7059
		33000 33700	33350	19300 20900	0,60 0,65	0,58 0,63	4,6793 4,5752
nails	44970	45500 47000	46250	38220	0,85	0,83	3,8352
		45800 47200	46500	40470	0,90	0,87	4,6502
		43500 41400	42450	26980 33730	0,60 0,75	0,64 0,80	>5,0808 >5,0180
		43200 45700	44450	26980 29230	0,60 0,65	0,61 0,66	>5,0808 >5,0208

- 1) Failed outside joint
- 2) Failed during loading.

4.4. Deformations

All deformations have grown steadily from the time of loading during the whole tests. In most cases the curves are smooth and they do not show

a very distinct pattern.

It is difficult to decide from these curves if there exists a certain warning point for coming failure. The splitting joints of load levels 0,60 and 0,65 perhaps do demonstrate such a warning after about 1100 hours, failure takes place after about 1300 hours. The higher load levels give less smooth curves. The Bulldog connector joints show very smooth curves, which lead directly to failure or to a very steep increase in deformation and then to failure. This holds for the lower and for the higher load levels upto 0,80. For level 0,85 the curves show a continuously increasing rate of deformation (on the log t scale!) until failure.

The nailed joints of load levels 0,60 and 0,65 show after 1600 hours a clear increase of the creep deformations. These specimens are tested in two series of four, each series loaded separately. Probably the increased rate of deformation has something to do with changes in the atmosphere; some 700 to 1000 hours later the deformations are more or less back on their old curve. The specimens were loaded in September (5 resp. 6 September 1962). The test specimens at higher load levels show different behaviour.

The maximum deformations are different for the three types of joints. For split-ring-joints they range roughly from 2 to 4 mm, for Bulldogconnector joints from 3 to 16 mm, and for nailed joints from 11 to 22 mm, where the lower load levels are not yet finished, but where deformations of 6 to 10 mm occur.

Some creepfactors $C = \frac{\text{creep deformation}}{\text{initial deformation}}$ at distinct times have been given in table 10.

It was not possible as yet to study in detail the effect of changes in temperature and humidity of the air on the deformations of the joints. In a later stage some attention to these aspects will be given.

Conclusions

From the results of the investigation it becomes clear that the prediction of the short-duration-strength of a certain type of joint can not be very precise; it is not sure that matching of the jointed members has given much help in this respect. In the investigation this doubtful effect of matching resulted in the determination of the long-duration loads on the basis of mean values rather than on individual strength values of matched joints.

Despite the rather large variations in strength values and the low values there of, especially with the split-ring-joints, the trend of the investigation seems to show that the effect of duration of load is somewhat smaller than expected on the basis of the generally for wood adopted Madison relationship. Especially nailed joints showed this tendency.

The smaller effect of load duration is not yet as distinct for longer times as for the shorter times in the investigation; the nailed joints seem to demonstrate also at the lower load levels longer time-to-failure values. The investigation will be proceeded with the remaining joints and 35 new joints during the next years.

fig. 8. Time to failure; split-ring joints.

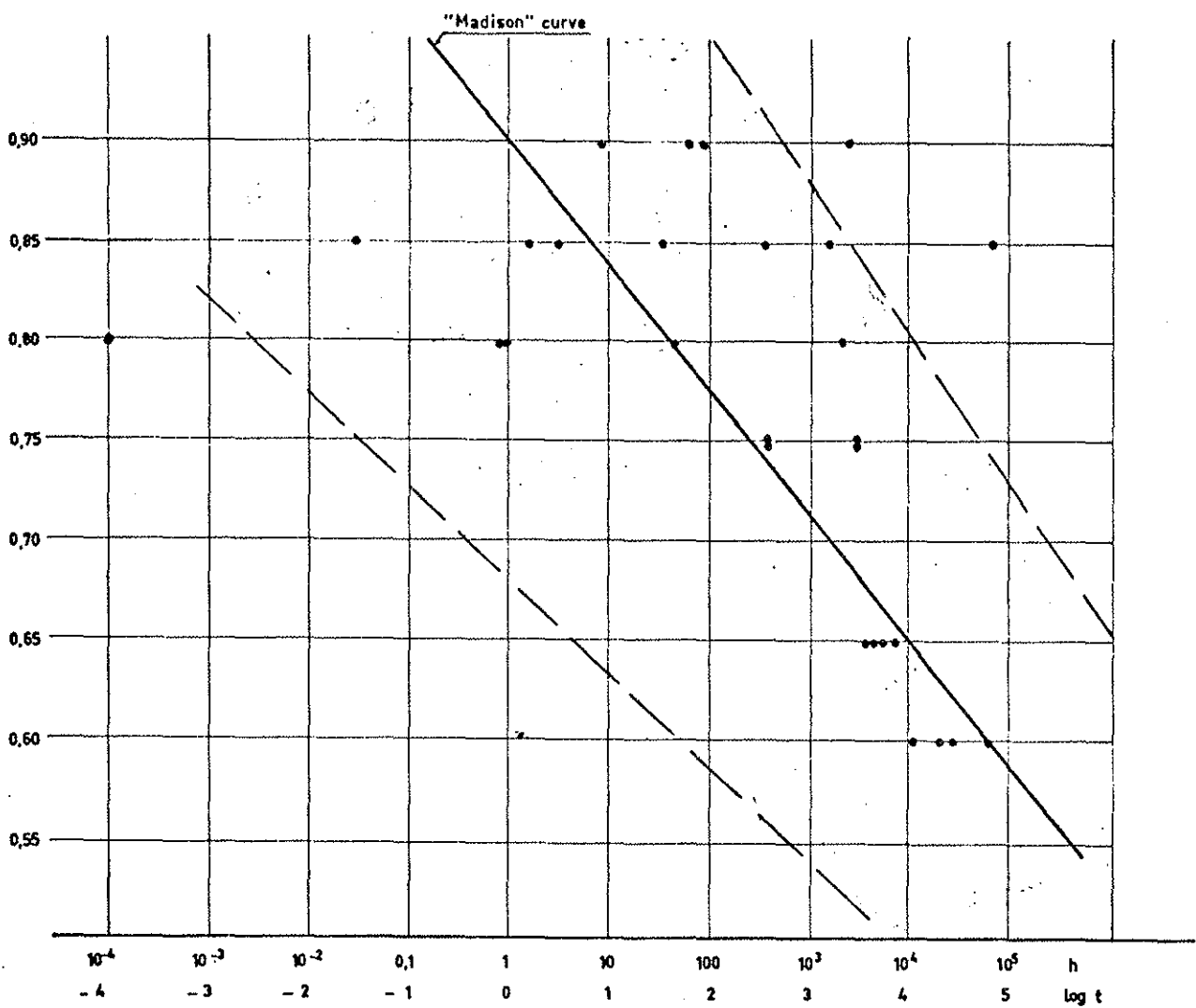

90% of test results may be expected in the shadowed area.

fig. 9. Time to failure ; toothed plate joints.

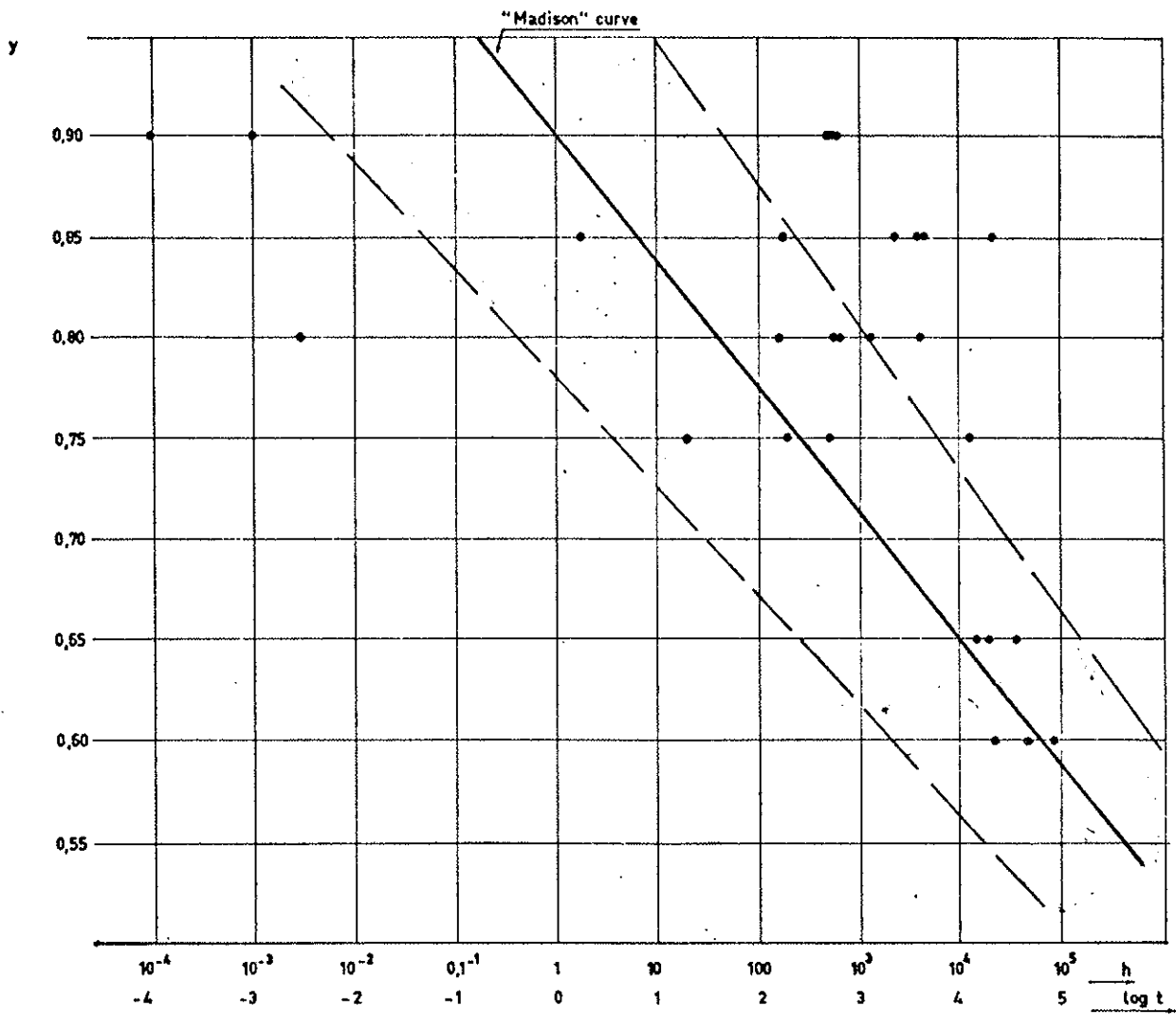

90 % of test results may be expected in the shadowed area.

fig. 10. Time to failure ; nailed joints.

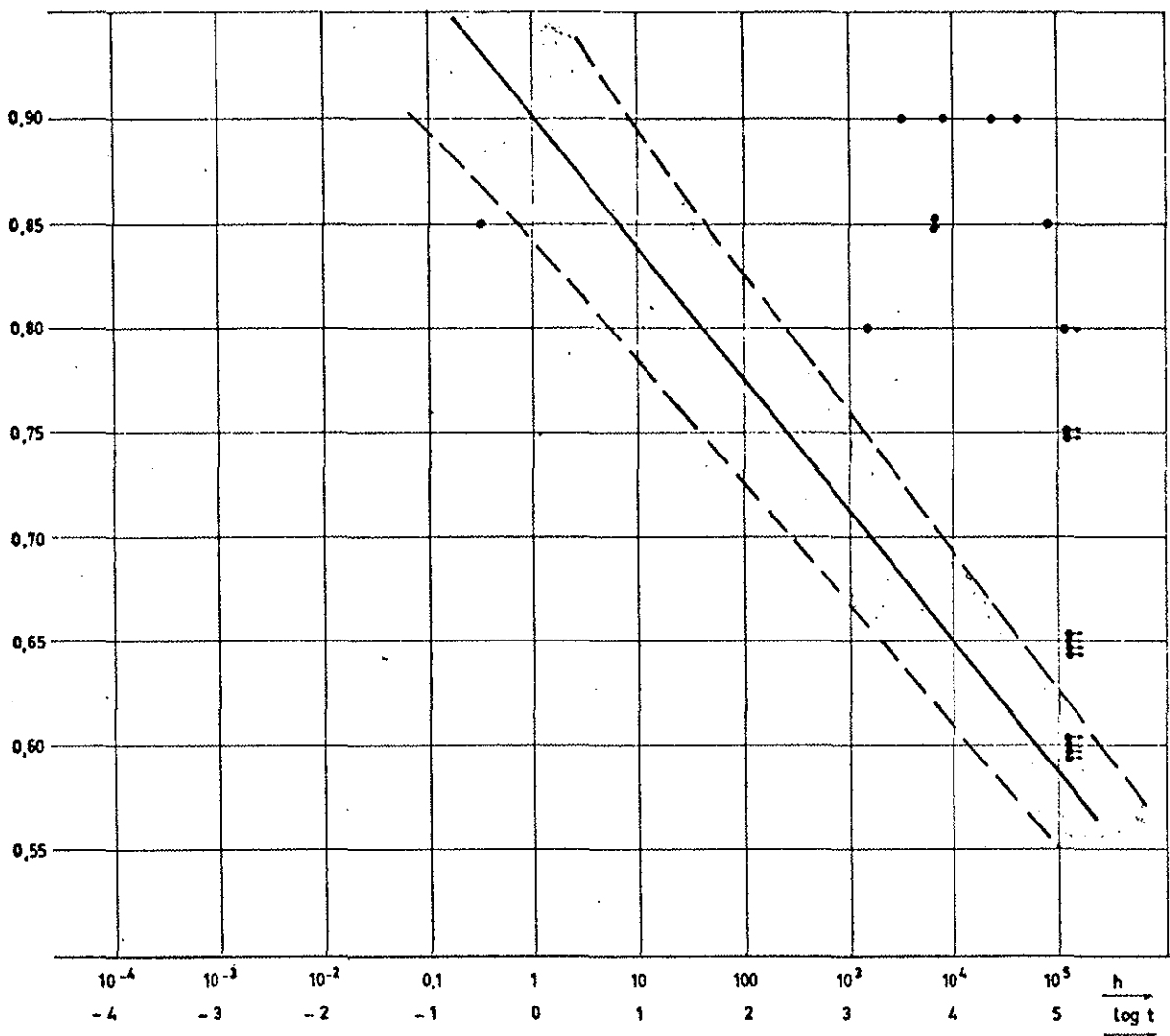

90 % of test results may be expected in the shadowed area.

split-rings

VERSCHUIVING

RINGEIJVELVERBINDING

RINGEIJVEL 73 MM

NR.	ES	NOM. SEL. Y	DIR. VPL.	MM	N	MM
35A 1	85	17280	0.60	0.67		
35A 2				0.76		
35A 3				0.62		
35A 4				0.62		
35A 5	95	12730	0.65	0.81		
35A 6				0.89		
35A 7				1.06		
35A 8				0.90		
35A 17				0.68		
35A 18				1.10		

Δ = BREEKPUNT

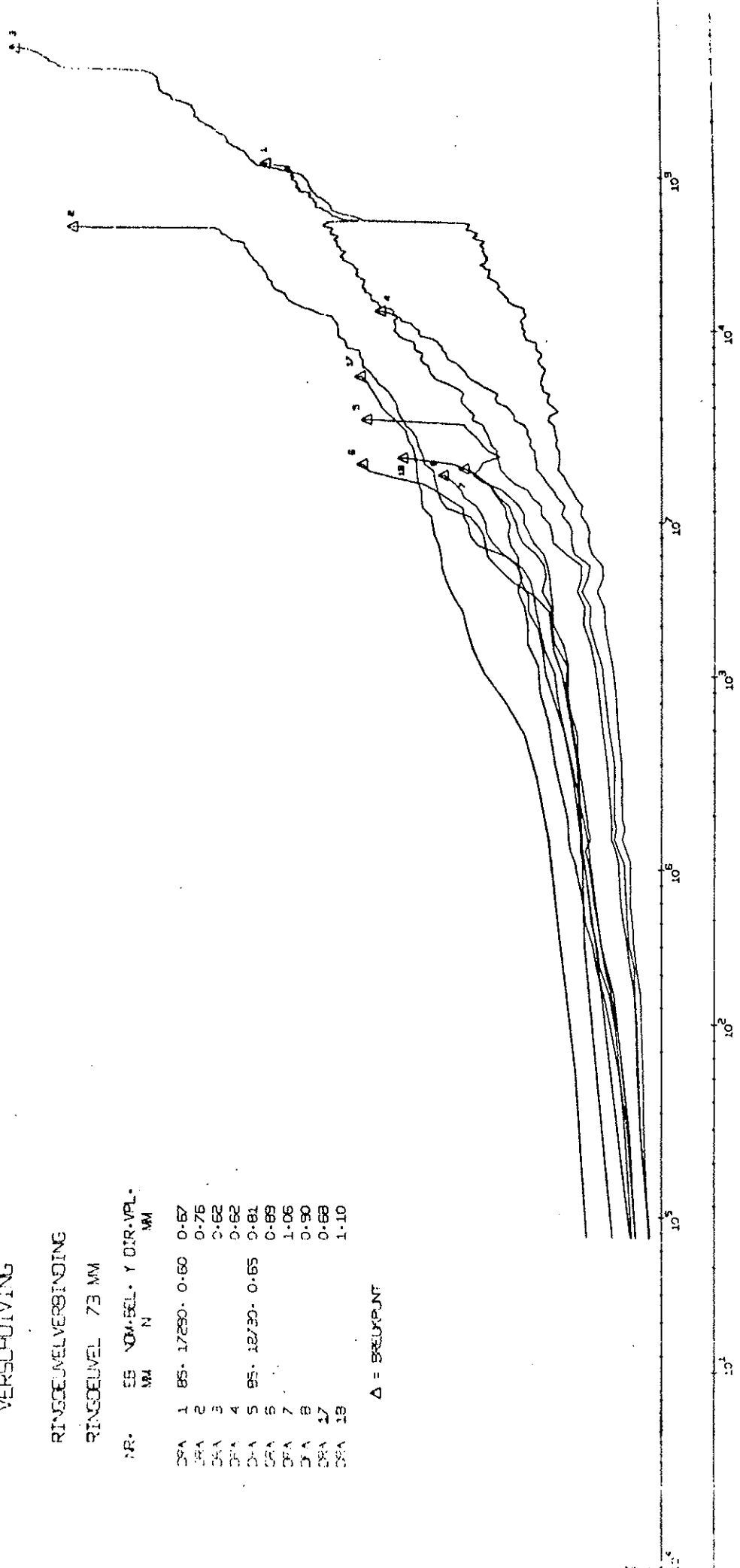

split-rings

VERSCHUIVING

RINGDEUVELVERBINDING

RINGDEUVEL 73 MM

NR.	ES	NOM-BEL.	Y	DIR-VPL.	MM
	VM	N			
DPA 9	85	21620	0.75	0.85	
DPA 10				0.53	
DPA 14				1.48	
DPA 11		23050	0.80	1.17	
DPA 15				0.85	
DPA 20		24500	0.85	0.99	
DPA 27				1.15	
DPA 21		25940	0.90	1.53	

Δ = BREUKPUNT

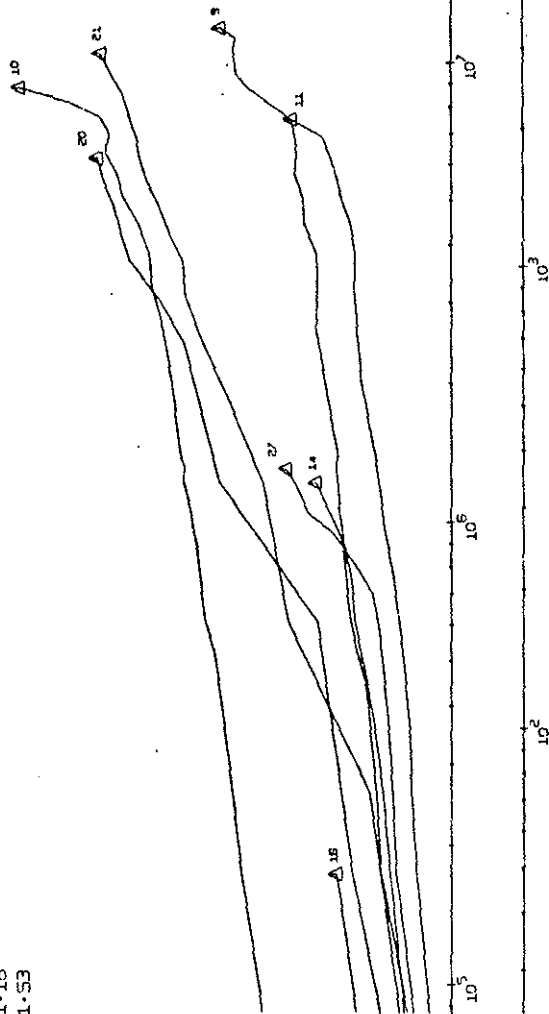

toothed plates

VERSCHUIVING

KRAANPLAATVERBINDING

KRAANPLAAT 75 MM

NR.	ES	NO.-BEL.	Y DIR.	VL.	MM	N	MM
DKA 1	75	19300	0-50	1-79			
DKA 2				1-83			
DKA 3				1-97			
DKA 4				2-53			
DKA 5		20920	0-65	2-33			
DKA 6				2-81			
DKA 7				2-55			
DKA 8				1-97			

Δ = BREUKPUNT

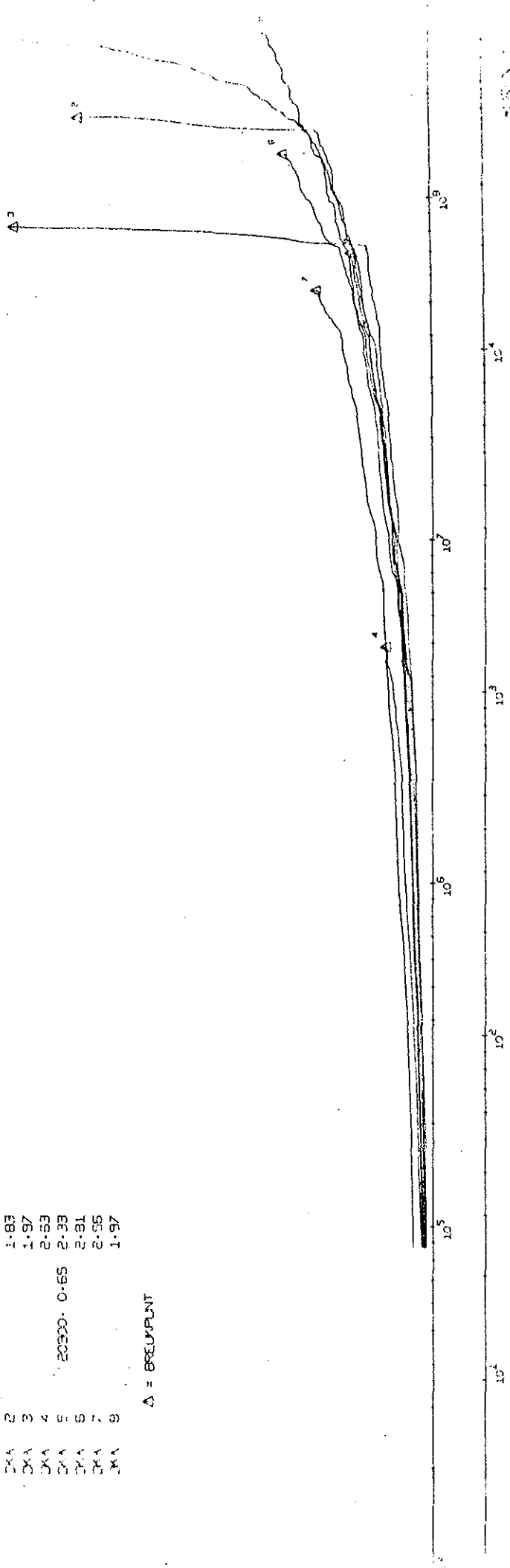

toothed plates

VERSCHUIJVING

KRAMPLAATVERBINDING

KRAMPLAAT 75 MM

NR.	ES	MM	N	DIR.VPL.	MM
DKA 13	75	27340	0.95	3.17	
DKA 14				3.50	
DKA 20				2.44	
DKA 22				3.68	
DKA 26				3.05	
DKA 17	28940	0.90	3.04		
DKA 21			2.76		
DKA 27			3.97		

Δ = BREEKpunt

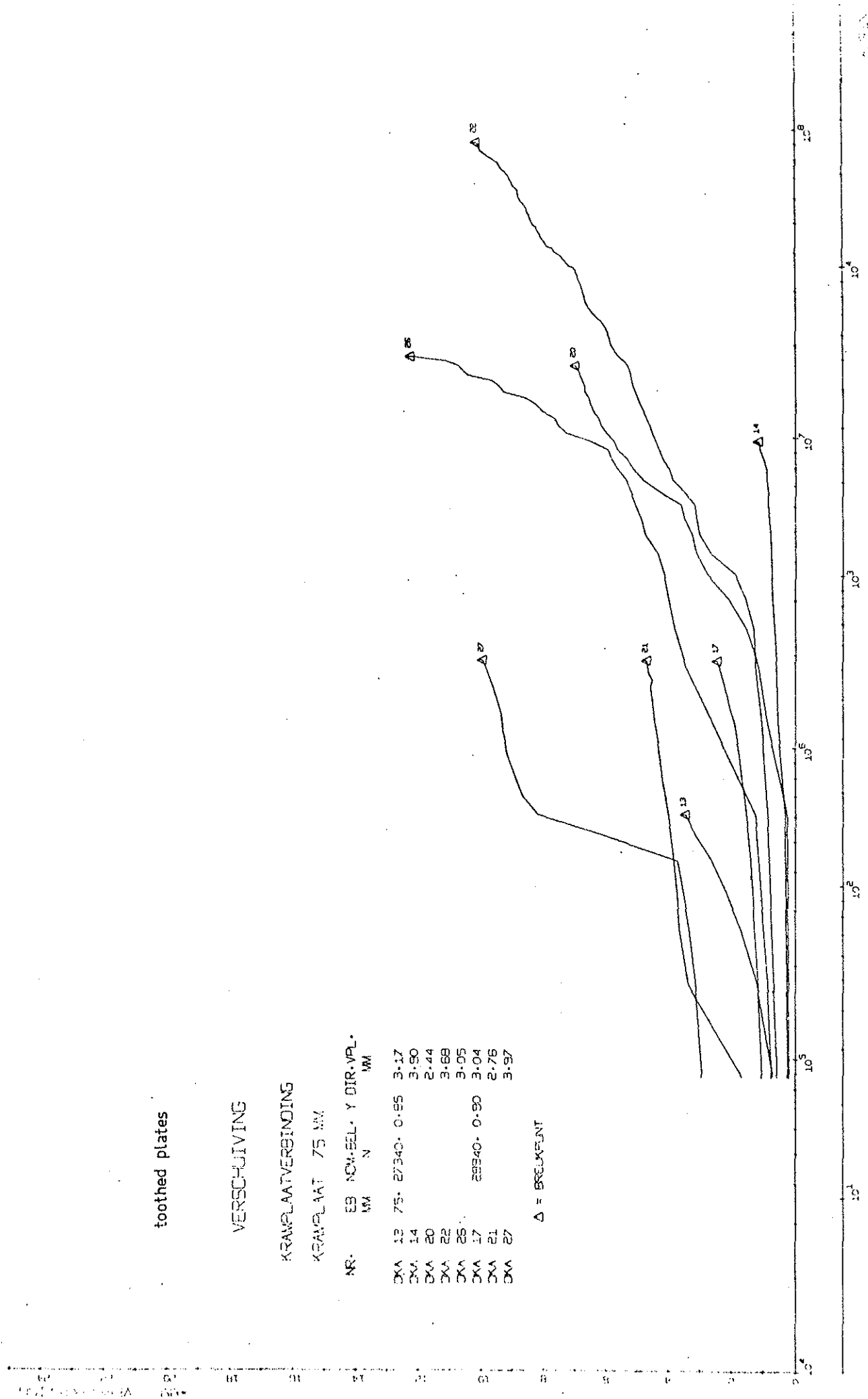

toothed plates

VERSCHUIVING

KRAUPLAATVEREINIGING

KRAUPLAAT 75 MM

NR.	ES	MM	N	MM	Y DIR. VPL.	MM
00A	5	75	24120	0.75	2.98	
00A	10				2.99	
00A	15				3.61	
00A	12	75	25730	0.80	2.98	
00A	13				2.83	
00A	23				2.89	
00A	25				2.75	
00A	29				2.94	

Δ = BREUKPUNT

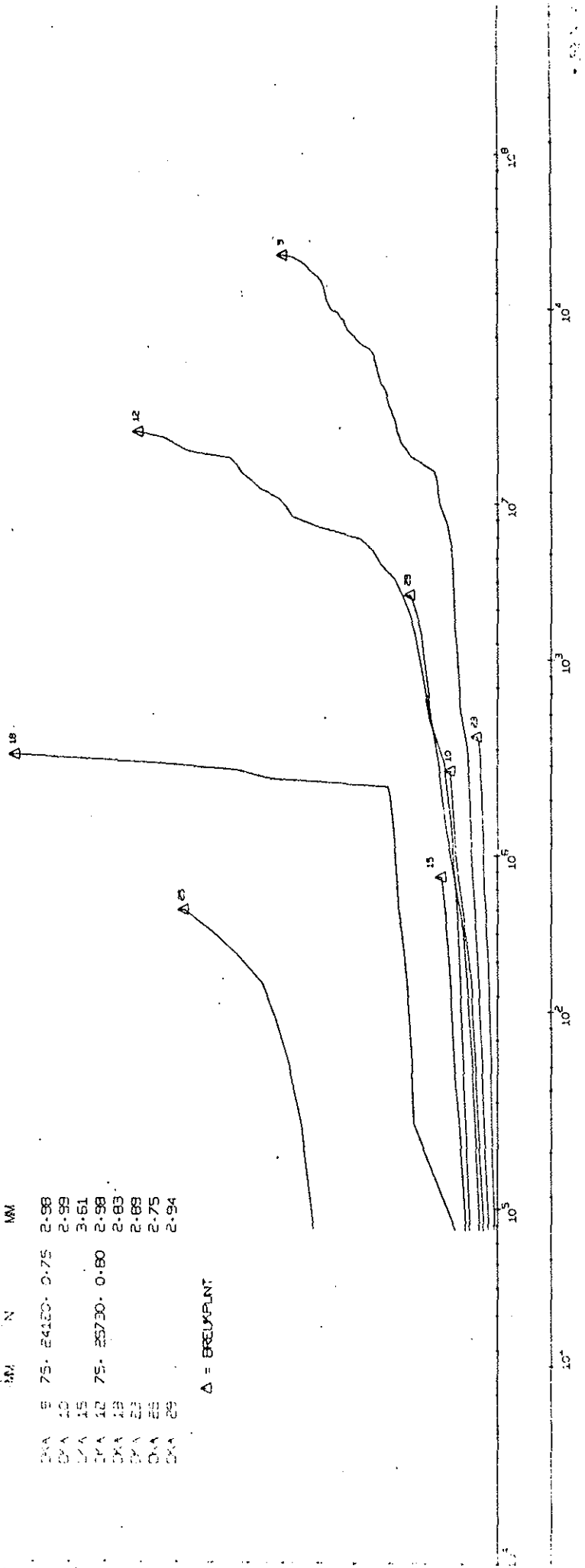

MM = VERSCHIJVING

nails

VERSCHIJVING

DRAAGVAGELVERBINDING

80 DRAAGVAGELS 45X2.8

NR.	EB	MM	MM	N	Y	DIR.	VPL.
DVA 1	34	26980	0	50	1	71	
DVA 2						78	
DVA 3						42	
DVA 4						59	
DVA 5	34	28230	0	65	2	27	
DVA 6						61	
DVA 7						04	
DVA 8						95	

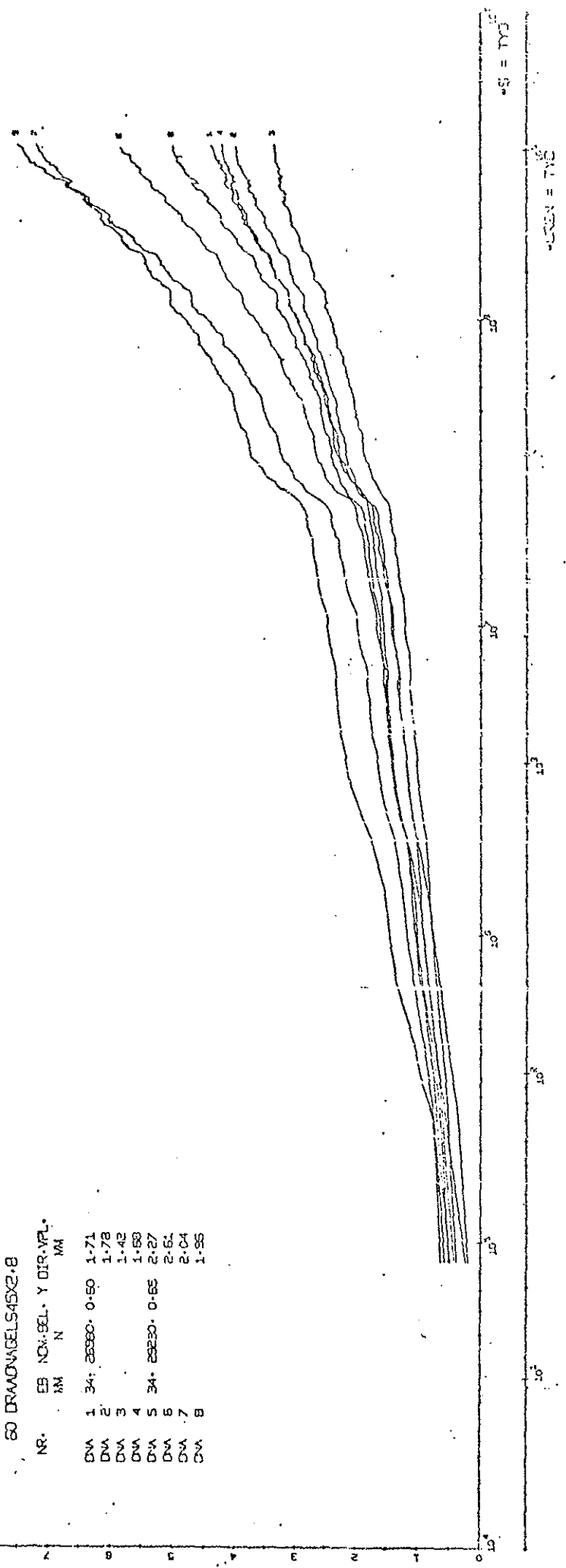

MS = TYP

MUSEN = TMS

AMMUN, CALSUDINIA CHANT BO 03

CHICORINA CEP 101 P 11

27

nails

VERSCHUIVING

DRAMAGELVERBINDING

60 DRAMNAGELS 45X2.8

NR.	EB	NOA-BEL.	Y	DIR-VFL.	MM
	MM	N			
DVA 9	34	33730	0.75	2.49	
DVA 10				2.72	
DVA 11	34	35560	0.80	5.33	
DVA 12				2.44	
DVA 14	34	36220	0.65	2.56	
DVA 18				4.40	
DVA 26				3.05	
DVA 15	34	40470	0.90	4.20	
DVA 16				3.76	
DVA 17				1.69	
DVA 19				3.41	

Δ = BREUKPUNT

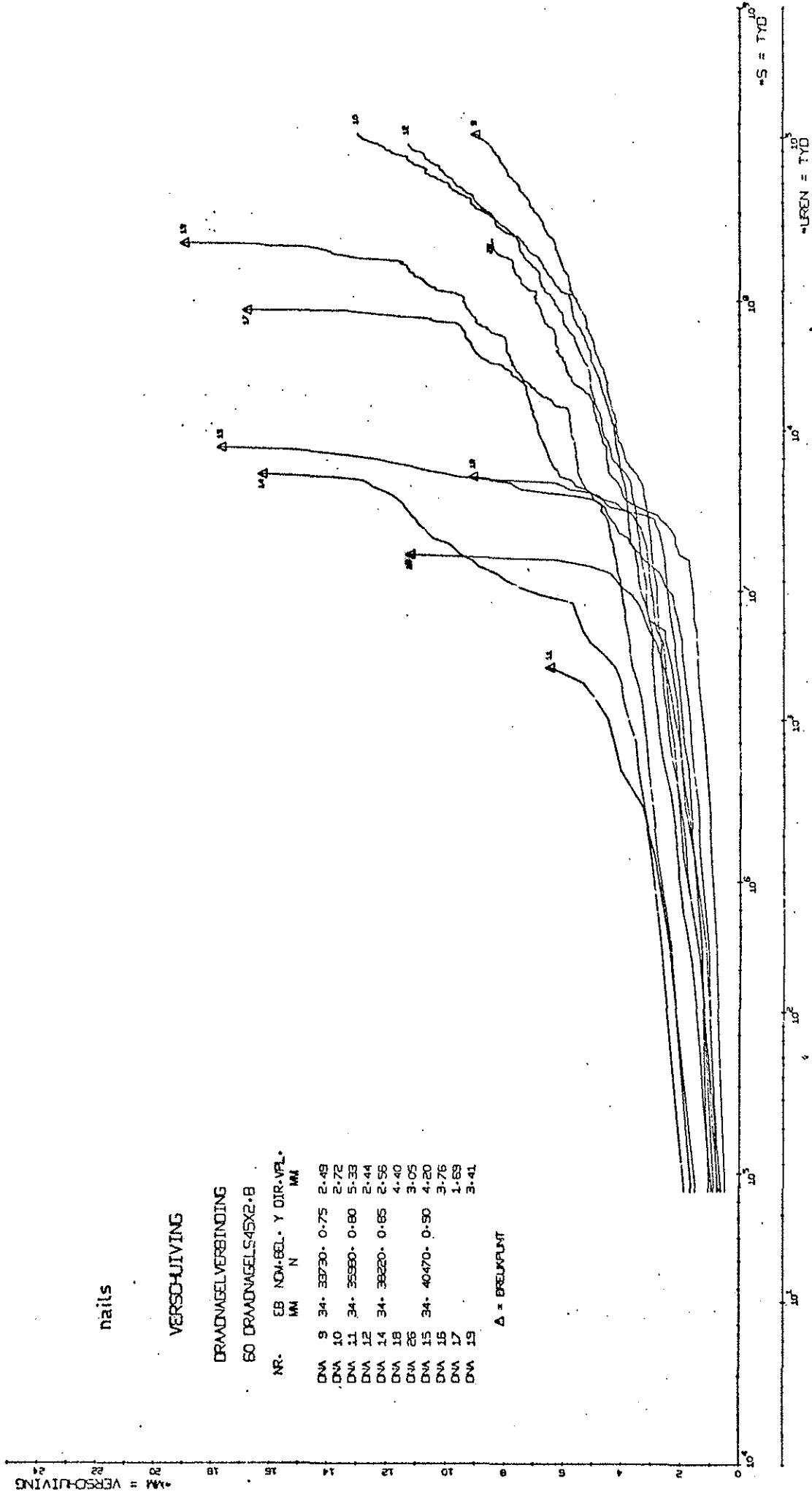

*S = TYD
*LREN = TYD

CIB-W18/7-7-3

INTERNATIONAL COUNCIL FOR BUILDING RESEARCH STUDIES AND DOCUMENTATION

WORKING COMMISSION W18 - TIMBER STRUCTURES

TESTS WITH MECHANICALLY JOINTED BEAMS WITH

A VARYING SPACING OF FASTENERS

by

K MOHLER

Universität Karlsruhe (TH)

Karlsruhe

STOCKHOLM, SWEDEN - FEBRUARY/MARCH 1977

spacing of the fasteners by inserting into the equation of γ

$$\gamma = \frac{1}{1 + \frac{\pi^2 \cdot A \cdot E}{l^2 \cdot k} \cdot s'_{ef}} \rightarrow s'_{ef} = \frac{k}{E} \cdot \frac{l^2}{\pi^2 \cdot A} (1 - \gamma) \cdot \frac{1}{\gamma}$$

The s -values received are compared in table 1 to those values given by the formulas from Köster [1] and Larsen [2]. The comparison shows that the proposal from Köster

$$s'_{ef} = \frac{l}{n} (0,75 \cdot \min s + 0,25 \cdot \max s) \quad (n = \text{number of rows of fasteners})$$

is corresponding comparatively good to the test results, if the fasteners are arranged according to the course of the shear force.

As by a beam under uniform load also in the middle area, that is the area without nearly any shear force, a certain maximum spacing of the fasteners (e.g. $\max s = 4 \cdot \min s$ referred to the DIN 1052 for nail-connections) can not be exceeded, the result is in the most unfavorable case

$$s' = \frac{l}{n} \cdot 1,75 \min s.$$

Thereby the number of the fasteners can be reduced about 50% opposite to the DIN - procedure. The mathematical reduction of the J_{ef} consequently is less than the reduction of the number of the fasteners. Therefore it can be economical to arrange the fasteners according to the course of the shear force and not with a constant distance designed on the basis of the maximum shear force.

Literature

- [1] Köster, P. in: Neuere Karlsruher Forschungsarbeiten und Versuche im Ingenieurholzbau. Kapitel: Nachgiebig verbundene Biegeträger, Bauen mit Holz, Heft 6/1972
- [2] Larsen, H. in: CIB timber standard No. 02, Mechanically jointed beams and columns with I-, T- or box cross-sections, Draft No. 1, 15.12.1975

Aim of the Research Work

According to the theory of composite beams with yielding connections, on which the calculation method shown in the German standard DIN 1052 is based, the spacing of the fasteners must be constant, independent of the distribution of the shear force. Thereby the distance between the fasteners is calculated by means of the maximum shear force. In this case the connectors are required totally in regard to the slipresistance but not to the bearing capacity. Using a design analogous to the distribution of the shear force the number of fasteners used can be reduced remarkably. This would take an economical effect in regard to the reduced expenditure of work. The tests performed with beams in natural size should show whether the calculation method according to DIN 1052 can also be used for mechanically jointed beams with a varying spacing of fasteners if an effective distance s'_{ef} between the connectors is used in the calculation.

Testing Methods and Evaluation from Test Results

The main test programm with beams with cross-sections composed from 2 or 3 members were done after some pre-tests with small model-beams. The members used had the dimensions 6/12, 10/20 and 12/24 cm. The material was spruce of grade II. The wood had a medium moisture content of 14%, a density of 450 kg/m^3 , a strength in compression of $40,5 \text{ N/mm}^2$ and a mean elasticity modulus of $12\,040 \text{ N/mm}^2$. The beams tested were supported in two points with a span of 3,0 m and 6,0 m and were loaded by 4 equal loads. Nails 60/180 and drift bolts of 8,16 and 20 mm for diameter were used.

Loading the beams step by step the beam-deflections and the slip between the members were measured. Also the strains at the top and at the bottom of the members could be determined nearly until rupture. Using the values of the beams with a constant spacing of the fasteners the effective slip-modulus k at each loading step could be calculated. Knowing γ from the deflections measured before, s can be calculated for the beams with varying

beam number	I	II	III	IV	V	VI	VII	VIII	IX	X	XI	XII	XIII	XIV	XV	XVI	XVII	XVIII
min s [cm]	6	6	4,48	6	6	6	6	6	4,48	6	6	6	15	15	10	15	15	10
max s [cm]	6	12	15,08	6	12	18	6	12	15,08	6	12	18	15	50	20	15	50	20
1s ₁ [cm]	6	7,5	7,13	6	7,5	9,0	6	7,5	7,13	6	7,5	9,0	15	23,75	12,5	15	23,75	12,5
2s ₂ [cm]	6	8,00	10,05	6	8,00	12,00	6	8,00	10,05	6	8,00	12,00	15	33,33	13,33	15	33,33	13,33
3"s _{ef} " [cm]	6	8,15	6,24	6	7,23	9,71	6	6,08	6,32	6	7,30	9,22	15	21,42	15,80	15	23,78	19,04
$\frac{1-3}{3} \cdot 100$ [°/o]	0	-7,98	14,26	0	3,73	-7,31	0	23,36	12,82	0	2,74	-2,39	0	10,88	-20,89	0	-0,13	-34,35
$\frac{2-3}{3} \cdot 100$ [°/o]	0	-1,84	61,06	0	10,65	23,58	0	31,58	59,02	0	9,59	30,15	0	55,60	-15,63	0	40,16	-29,99

$$1) s_1 = 0,75 \cdot \min s + 0,25 \cdot \max s \quad (\text{Köster})$$

$$2) \left. \begin{array}{l} s_2 = \frac{2}{3} \cdot \max s \\ s_2 = \min s \end{array} \right\} \text{ use the greater of both values } (\text{Larsen})$$

table 1. Comparison of the test - results s_{ef} with the values according to the formulas of Köster[1] and Larsen [2]

INTERNATIONAL COUNCIL FOR BUILDING RESEARCH STUDIES AND DOCUMENTATION

WORKING COMMISSION W18 - TIMBER STRUCTURES

CODE RULES CONCERNING STRENGTH AND LOADING TIME

by

H J LARSEN and E THEILGAARD

Instituttet for Bygningsteknik

Aalborg

STOCKHOLM, SWEDEN - FEBRUARY/MARCH 1977

CODE RULES CONCERNING STRENGTH AND LOADING TIME.

0. INTRODUCTION

In connection with the preparation of an inter-Nordic timber code, the practical possibilities of taking the relationship between load level and time to rupture into consideration have been discussed. Among other things, the advantages of and possibilities for using the principles presented in [1] have been discussed.

On the basis of the following considerations, among others, it was decided to continue the present procedure where the strength parameters are adjusted according to the shortest load-duration of the load combination.

It is noted that loading group division and time dependence in the following have been chosen according to current practice in the Nordic countries and will be adjusted in conformity with the CIB-W18 decision.

1. CONSTANT LOAD

In the following the relationship between load level, p , and time, t , to rupture is assumed to be known.

In the Nordic countries it has so far been assumed that the reference value, p_0 , for timber corresponds to a loading time of about 10^{-1} h, while the minimum value, about $0.6 p_0$, is reached in the interval $10^5 - 10^6$ h (10 - 100 years). The relationship between p/p_0 and $\log t$ is considered linear.

In conformity with [1]* a slightly deviating relationship is assumed, i.e.

$$p/p_0 = \begin{cases} 1 & \text{for } t \leq 1 \text{ h} \\ 1 - 0.08 \log t & \text{for } t \geq 1 \text{ h} \end{cases} \quad (1)$$

which gives convenient calculations, and is therefore used in the following fundamental calculations.

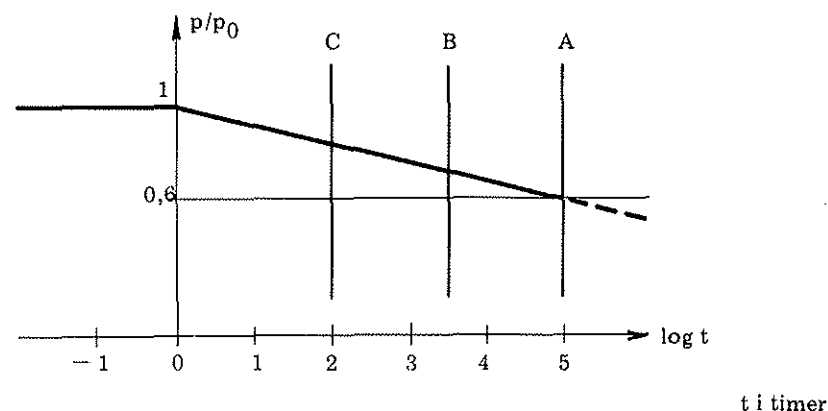

Fig. 1

* [1] Bengt Noren: Long-term loading for the code of practice. CIB-W18/6-9-1, Aalborg 1976.

Hitherto, it has been assumed in the Nordic countries that the load is divided into 3 groups, i.e. long-term load (load group A), a middle group (load group B), and short-term load (load group C). The strength parameters for timber corresponding to these groups are $0.6 p_0$, $1.2 \cdot 0.6 p_0$, and $1.4 \cdot 0.6 p_0$.

In conformity with the curve in fig. 1 the load groups correspond to load durations of 10^5 , $10^{3.5}$ (~ 4 months) and 10^2 hours.

2. FLUCTUATING LOAD

2.0 General

The problem is how to incorporate the relationship assumed in section 1 into code rules for structures which in the period $0 \leq t \leq t_1$ are loaded to the level p_1 and, additionally, during part of this period (total time t_2) to the level $(p_1 + p_2)$, and in part of this time (t_3) further to $(p_1 + p_2 + p_3)$, cf. fig. 2. In the figure all loads are assumed to be applied at $t = 0$ and reduced at t_3 , t_2 , and t_1 . In practice, the periods of time, where the load level is $(p_1 + p_2)$ or $(p_1 + p_2 + p_3)$, can be distributed over a number of periods. The choice of three load levels is due to the desire to relate the following to the division used so far.

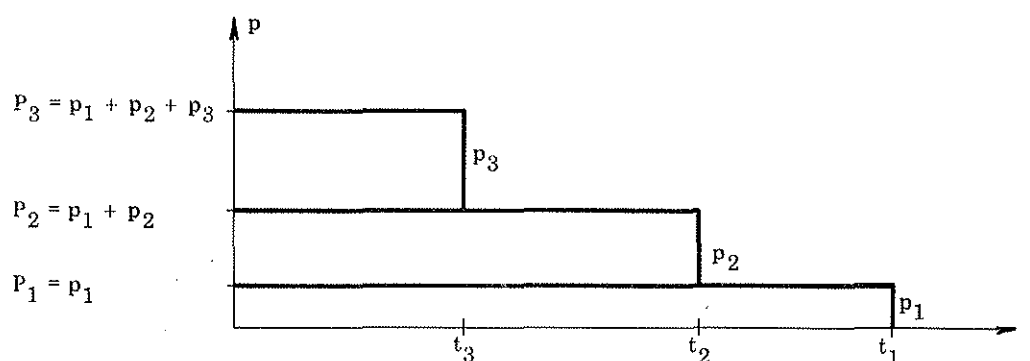

Fig. 2

Rules have to be fairly simple to be included in a code. Therefore, there are only two possibilities in practice, namely adjustment of the strength parameters dependent upon the time distribution of the load or modification of the real loads, so that they are converted into a common duration, normally to an equivalent long-term load.

2.1 Adjustment of the strength parameters

A very simple method is used in the current editions of timber codes in e.g. Denmark, Norway, and Sweden: The strength parameters are determined corresponding to the duration of the shortest loads of the load combination. With reference to fig. 2 this means that the structure is only investigated immediately before the times t_1 , t_2 , and t_3 . The strength reduction, which a load with shorter duration might cause, is thus disregarded.

The method has worked satisfactorily and has great advantages where calculations are concerned.

- For example, it is possible in many cases to set up design formulas.
- The detailed investigation can often be reduced to a single load situation, whereupon it is shown by rough calculations that the other load combinations are acceptable.
- Different signs on the individual load contributions give no complications.

A more complicated method was used in the previous edition of the Danish timber code. The strength parameters corresponding to long-term load for timber were increased by the factor

$$(\sigma_A + 1.2\sigma_B + 1.4\sigma_C)/(\sigma_A + \sigma_B + \sigma_C)$$

Here σ_A , σ_B , and σ_C are the stress contributions (or force contributions) from loads belonging to groups A, B, and C, respectively. The factors 1.2 and 1.4 may be different for other materials. The method has no theoretical background, but was simply chosen as the simplest interpolation formula. It was given up because ordinary users had great difficulty in using it correctly, even in the simplest cases. (In more complicated cases, e.g. where the stress contributions have different signs and are due to different internal forces with unequal combinations of A-, B- and C-loads even the more advanced users can have difficulties).

A further drawback was that it was only possible to set up design expressions for the simplest cases (all stress contributions of the same type and with the same sign).

More complicated interpolation formulas can be set up according to the same principles as used in the following section. They will have the same drawbacks (and advantages, if any) as mentioned there.

2.2 Adjustment of the loads

The short-duration load contributions are reduced to equivalent long-term loads. The reduction factor can be determined from the accumulated duration of the load contribution alone, or more specifically, from the time variation of the load, taking into consideration the rheological properties of the materials. An example of such an evaluation is given in [1]. Determination of equivalent loads can be made for the individual load or for the entire load combination, where, for example, the equivalent value of a snow load depends on the size of the snow load in relation to dead load, wind load, etc.

The disadvantage of this method is that the loads - and with that the internal force calculation - are different for e.g. timber members, board materials, joints and any members of other materials. In more complicated cases, e.g. live load on statically indeterminate structures, especially when the loads do not have the same direction - it can be almost impossible to determine the correct load set-up. In principle it will be necessary to investigate the conditions both to t_2 and t_3 (cf. fig. 1) with the »true» loads and to $t = t_1$ with the equivalent long-term loads. Design formulas cannot normally be set up, but in most cases proof of the adequacy of a selected structure will be required.

3. THEORETICAL EVALUATIONS

As a background for an evaluation of the different methods a simple rupture theory is used according to which the destruction of a material at a given load level is proportional with time; however, the destruction rate varies with the load level corresponding to the curve in fig. 1.

For a given load level $P_j = \sum_{i=1}^j p_i$ the time to rupture, T_j , is found by (1)

$$T_j = 10^{12.5(1-P_j/p_0)} \quad (2)$$

and for the load case shown in fig. 2 the described rupture condition gives

$$\frac{t_3}{T_3} + \frac{t_2 - t_3}{T_2} + \frac{t_1 - t_2}{T_1} = 1 \quad (3)$$

Inserting (2) and assuming $t_1 = 10^5$, $t_2 = 10^{3.5}$, and $t_3 = 10^2$ we get the following equation to determine the permissible combinations of loads belonging to the different load groups:

$$10^{12.5 \cdot P_3/p_0 - 10.5} + 0.9684[10^{12.5 \cdot P_2/p_0 - 9} + 10^{12.5 \cdot P_1/p_0 - 7.5}] = 1 \quad (4)$$

Results for the simple cases with $p_3 = 0$ or $p_2 = 0$ are given in table 1, assuming $p_A = 0.6 p_0$.

Table 1

$\frac{p_1}{p_A}$	$\frac{p_1}{p_0}$	$p_3 = 0$		$p_2 = 0$	
		$\frac{p_1 + p_2}{p_0}$	$\frac{p_1 + p_2}{p_A}$	$\frac{p_1 + p_3}{p_0}$	$\frac{p_1 + p_3}{p_A}$
1,00	0,60	0,600	1,00	0,600	1,00
0,99	0,594	0,661	1,10	0,776	1,29
0,97	0,582	0,690	1,15	0,809	1,35
0,94	0,564	0,705	1,18	0,825	1,37
0,90	0,540	0,713	1,19	0,833	1,39
0,80	0,480	0,719	1,20	0,839	1,40
0,70	0,420	0,720	1,20	0,840	1,40

It is seen that the influence from the load contributions p_2 and p_3 on the long-term strength is very slight, i.e. the simplest method mentioned in section 2.1, namely just investigating the structure to the times t_1 , t_2 , and t_3 , gives a very satisfactory approximation, especially when $p_2 = 0$, i.e. the difference in loading time of the two significant load contributions is rather large.

This approximation must be most critical where

$$\begin{aligned}
 P_1 &= p_A \\
 P_2 &= 1.2 p_A \\
 P_3 &= 1.4 p_A
 \end{aligned} \tag{5}$$

To estimate how much the approximation is on the unsafe side, we insert

$$\begin{aligned}
 P_1 &= \alpha p_A \\
 P_2 &= 1.2 \alpha p_A \\
 P_3 &= 1.4 \alpha p_A
 \end{aligned} \tag{6}$$

into equation (4), which gives an equation for determination of α . By iteration we get

$$\alpha = 0.947 \tag{7}$$

Thus, the maximum error will be of the order of 5%.

If p_A is assumed a few per cent lower than actually found from long-term tests, it is possible to calculate entirely on the safe side.

CIB-W18/7-13-1

INTERNATIONAL COUNCIL FOR BUILDING RESEARCH STUDIES AND DOCUMENTATION

WORKING COMMISSION W18 - TIMBER STRUCTURES

FIBRE BUILDING BOARDS FOR CIB TIMBER CODE

(FIRST DRAFT)

by

O BRYNILDSEN

Norsk Treteknisk Institutt

Oslo

STOCKHOLM, SWEDEN - FEBRUARY/MARCH 1977

Introduction

This draft has been prepared for discussion at the CIB W18 Meeting in Stockholm 1977.

It has been drafted to fit into the CIB Timber Code clause 4.2.3.

The CIB Timber Code suggests the following list of contents:

4. MATERIAL SPECIFICATIONS AND CHARACTERISTIC VALUES

4.2 Sheet material

4.2.3 Fibre boards

4.2.3.0 General, including claims of tolerances etc.

4.2.3.1 Special conditions in connection with material specifications including grading principles

4.2.3.2 Special conditions in connection with testing

4.2.3.3 Special conditions in connection with determination of characteristic values

For preparing the paper the following literature has been used:

SBN Godkännande regler 1975:5, Stockholm 1975

SBN 1975, Svensk byggnorm, Stockholm 1975

Brynildsen, Larsen and Norén: Structural use of particle board and fibre board, IUFRO, Oslo 1976.

4.2.3.0 General

Structural fibre boards are manufactured in three grades:

	Nom. Thickness, mm			
S-board 50 Oil-tempered	3	4.5	6	9
S-board 35 Hard	3	4.5	6	9
S-board 13 Semi-hard	5	9	12	16

The nominal thickness is the mean thickness for a single board.

4.2.3.1 Material specification

The water absorption and thickness swelling as calculated mean values for a single board shall not exceed the following values:

	Max. water absorption %	Max. thickness swelling %
S-board 50	10	5
S-board 35	30	20
S-board 13	30	10

The characteristic strength values (5-percentiles) shall not be less than the following values:

	Thickness mm	Bending strength N/mm ²	Tension perpend. N/mm ²
S-board 50	W 3	52	0.85
	V 3	44	0.85
S-board 35	W 3	36	0.65
	V 3	31	0.65
S-board 13	5-16	13.5	0.11

The characteristic short term dry strength (5-percentile) and stiffness (30-percentile) values are:

	S-board 50		S-board 35		S-board 13
Thickness, mm	3	4.5-9	3	4.5-9	5-16
Density, kg/mm ³	>800	>800	>800	>800	400-800
<u>STRENGTH, N/mm²</u>					
Bending	52	44	36	31	13,5
Tension in plane	30	25	25	22	6
Tension perp.	.85	.85	.65	.65	.11
Compr. in plane	25	23	19	17	6
Panel shear	19	16	16	14	3,5
Rolling shear	3	2.5	2	1.8	.4
<u>STIFFNESS, N/mm²</u>					
In plane E-modulus					
Bending)					
Tension)	6500	6500	?	?	2500
Compression)					
In plane G-modulus	3250	3250	?	?	1250

4.2.3.2 Testing

The properties of structural fibre board shall be established by tests according to the following standards on TEST METHODS FOR RIGID FLAT SHEETS:

- NS 3251^{x)}: Apparatus and general testing condition
- NS 3252: Modulus of elasticity in bending and bending strength
- NS 3253: MoE in tension and tensile strength. (Not yet available)
- NS 3254: Transversal internal bond (Tension perpendicular)
- NS 3255^{x)}: Density
- NS 3256^{x)}: Moisture content
- NS 3257^{x)}: Water absorption and swelling in thickness

x) English translations as appendices to this paper.

4.2.3.3 Characteristic strength and stiffness values for design

The characteristic strength and stiffness values for design are derived from the table clause 4.2.3.1 by multiplication with the factors below, which are dependent on the climate class and the load duration class.

Load duration		Permanent	Normal	Short term	Inst.
STRENGTH VALUES		.70	1.00	1.25	1.5
Climate 0	.44	.31	.44	.55	.66
Climate 1	.40	.28	.40	.50	.60
Climate 2	.25	.18	.25	.30	.38
STIFFNESS VALUES		.50	1.00	1.50	2.00
Climate 0	.40	.20	.40	.60	.80
Climate 1	.30	.15	.30	.45	.60
Climate 2	.15	.08	.15	.22	.30

NS 3251

RIGID FLAT SHEETS. TEST METHODSApparatus and general testing conditions

This standard is in agreement with corresponding standards in Denmark and Sweden.

1 SCOPE

This standard forms a part of a series of general test methods and lay down specifications for frequent occurring testing apparatus and states general testing conditions, see comments.

2 SPECIFICATIONS FOR APPARATUS AND GENERAL TESTING CONDITIONS FOR TEST PIECES

2.1 Conditioning

The test pieces shall be conditioned until constant mass has been reached in an atmosphere of relative humidity of $(50 \pm 5) \%$ and a temperature of 20 ± 2 °C, the conditioning though to be lasting for at least 48 hours if not more time is required in the individual product standard or in each testing method for rigid flat sheets.

Constant mass is considered to be reached when the results of two successive weighing operations, carried out at an interval of 24 hours, do not differ by more than 0,1 % of the mass of the test piece.

When the test pieces is to be conditioned in air, they shall be kept in such a way that form and dimensional changes can take place without any hindrance, and such that the air can circulate alongside all the sides of the test piece at a speed of 0,1 to 0,3 m/s.

2.2 Apparatus

See also comments.

2.2.1 Determination of mass

Balance which allows the determination of mass with an error less than 0,05 %.

2.2.2 Determination of thickness

Measuring instrument, having flat and parallel circular measuring surfaces of 10 ± 10 mm in diameter, which allows the determination of thickness with an error less than 0,01 mm.

The measuring load shall be 1 N.

2.2.3 Determination of length and width

Measuring instrument, sliding caliper or similar instrument which allows the determination of length with an error less than 0,1 mm.

The width of the measuring surfaces of the apparatus shall be 3 mm.

2.3 Procedure

For measuring the thickness the measuring surfaces of the measuring instrument shall be applied slowly to the test piece.

For measuring length and width with a sliding caliper, the jaw of the sliding caliper shall be applied slowly to the test piece at an angle of approximately 45° to the plane of the test piece (see Figure 1)

Thickness, width and length is determined in measuring points as specified in the Norwegian Standard for each test method concerned.

NS 3256

RIGID FLAT SHEETS. TEST METHODSMoisture content

This standard is in agreement with corresponding standards in Denmark and Sweeden.

1 SCOPE

This standard lay down a method of determining the moisture content of rigid flat sheets.

2 DEFINITION

Moisture content - the ratio of the mass of free water in a test piece and the mass of the test piece when dry.

3 PRINCIPLE OF THE METHOD

The moisture content is found by weighing the mass of each test piece in its state at the time of sampling and in its state after drying.

4 APPARATUS

4.1 Determination of mass

See NS 3251, point 2.2.1

4.2 Air connection drying oven, the temperature of which can be maintained at 103 ± 2 °C.

5 TEST PIECES

The test pieces can be of any shape, but the area shall be minimum 5000 mm^2 .

6 PROCEDURE

Each test piece shall be weighed immediately after sampling, and the mass is determined with an error less than 0,01 g. If the test pieces cannot be weighed within 5 minutes after sampling, all precautions should be taken to avoid variations of the moisture content during the time from sampling to weighing.

Each test piece shall be dried at a temperature of $103 \pm 2^{\circ}$ to constant mass.^{x)}

The test piece is to be weighed within 15 seconds or after cooling in dehydrater.

7 RESULTS

The moisture content of each test piece shall be calculated in accordance with the following formula.

$$H = \frac{M - M_0}{M_0} \cdot 100$$

Where

H is the percentage moisture content of the test piece.

M is the mass of the test piece at the time of sampling, to the nearest 0,01 g.

M₀ is the mass of the test piece after drying, to the nearest 0,01 g.

The moisture content of each test piece shall be noted.

8 TEST REPORT

The test report shall contain

the type of rigid flat sheet and all necessary details for identification

the results expressed as stated in point 7

the reference to this standard

REFERENCES

NS 3251. Rigid flat sheets. Test methods. Apparatus and general testing conditions.

x) Defined in NS 3251 point 2.1

TEST REPORT

The test report shall contain

The type of rigid flat sheet and all necessary details for identification.

The results expressed as stated in point 8.

The reference to this standard.

REFERENCES

NS 3251 Rigid flat sheets. Test methods. Apparatus and general testing conditions.

NS 3257

RIGID FLAT SHEETS. TEST METHODSWater absorption and swelling in thickness

This standard is in agreement with corresponding standards in Denmark and Sweden.

1 SCOPE

This standard lay down a method of determining the water absorption and swelling in thickness of rigid flat sheets.

2 DEFINITIONS

Water absorption - the increase in mass of the test piece after immersion in water.

Swelling in thickness - the increase in thickness of the test piece after immersion in water.

3 PRINCIPLE OF THE METHOD

The water absorption and swelling in thickness is found by weighing the mass and by measuring the thickness of each test piece before and after complete immersion in water.

4 CONDITIONING

Se NS 3251, point 2.1.

5 APPARATUS

5.1 Determination of thickness

Se NS 3251, point 2.2.2.

5.2 Determination of mass

See NS 3251, point 2.2.1

5.3 Testing apparatus

- 5.3.1 A thermostatically controlled tank, with a stirring device, the temperature of which can be kept at 23 ± 2 °C.
- 5.3.2 Wire screen with an aperture size of approximately 10 mm.

6 TEST PIECES

The test pieces shall be square in shape with sides measuring approximately 100 x 100 mm, see figure

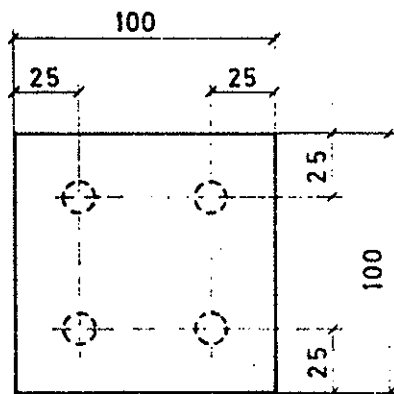

7 PROCEDURE

The test pieces shall be conditioned according to NS 3251 point 2.1 and are thereafter measured and weighed. The measuring procedure shall be done according to NS 3251 point 2.3.

The thickness shall be measured at the four different points as shown in the figure. The measuring points shall be clearly marked on the test piece. The mean arithmetical value of the four measurements is considered to be the thickness of the test piece.

Length and width shall be measured 25 mm from and parallel to the edges.

Each test piece shall be weighed and the mass is determined with an error less than 0,1 g.

Each test piece shall be weighed and measured before testing.

At the beginning of each test, the water shall have a pH value of 6 ± 1 , and the temperature shall be kept at 23 ± 2 °C during the test.

The test pieces shall be immersed vertically with the upper edges approximately 200 mm below the surface of the water. The test pieces shall be well separated from each other as well as from the bottom and sides of the tank.

The water absorption and swelling in thickness shall be registered 2 and 24 hours after immersion.

Before weighing and measuring of the immersed test pieces, they shall be placed on the wire screen having an inclination of 60° . The test pieces should be kept there in 60 ± 10 s in order to allow excess water to drip off.

Each test piece is then weighed and measured within 10 minutes in the same way as before immersion so that the mass and thickness again is determined.

8 RESULTS

8.1 Water absorption

The water absorption of each test piece shall be calculated in accordance with the following formula.

$$A_n = \frac{M_2 - M_1}{M_1} \times 100$$

hvor

A_n is the percentage water absorption after immersion in n hours where n shall be 2, respectively 24 hours

M_1 is the mass of the test piece after conditioning, to the nearest 0,1 g

M_2 is the mass of the test piece after immersion, to the nearest 0,1 g.

The water absorption of one sheet is obtained by calculating the arithmetical mean value of the results obtained on all test pieces taken from the same sheet.

The water absorption shall be calculated to the nearest 0,1 %.

8.2 Swelling in thickness

The swelling in thickness of each test piece shall be calculated in accordance with the following formulae

$$G_n = \frac{a_2 - a_1}{a_1} \times 100$$

where

G_n is the percentage swelling in thickness after immersion in n hours where n shall be 2, respectively 24 hours.

a_1 is the thickness of the test piece after conditioning, to the nearest 0,01 mm

a_2 is the thickness of the test piece after immersion, to the nearest 0,01 mm.

The swelling in thickness of one sheet is obtained by calculating the arithmetical mean value of the results obtained on all test pieces taken from the same sheet.

The swelling in thickness shall be calculated to the nearest 0,1 %.

9 TEST REPORT

The test report shall contain

the type of rigid flat sheet and all necessary details for identification

the results expressed as stated in point 8, including the state of conditioning

the results shall be stated for all tests

the reference to this standard

REFERENCES

NS 3251 Rigid flat sheets. Test methods. Apparatus and general testing conditions.

NS 3255

RIGID FLAT SHEETS. TEST METHODSDensity

This standard is in agreement with corresponding standards in Denmark and Sweden.

1. SCOPE

This standard lay down a method of determining the density of rigid flat sheets, where the volume is determined by measuring.

2. DEFINITION

Density - the ratio of the mass of the test piece to its volume when conditioned

3. PRINCIPLE OF THE METHOD

The mass in kg and the volume in m^3 of the test piece is found by weighing and measuring.

4. CONDITIONING

See NS 3251, point 2.1

5. APPARATUS

5.1 Determination of thickness

See NS 3251, point 2.2.2

5.2 Determination of length and width

See NS 3251, point 2.2.3

5.3 Determination of mass

See NS 3251, point 2.2.1

6 TEST PIECES

The test pieces shall be square in shape with sides measuring approximately 100 x 100 mm, see figure.

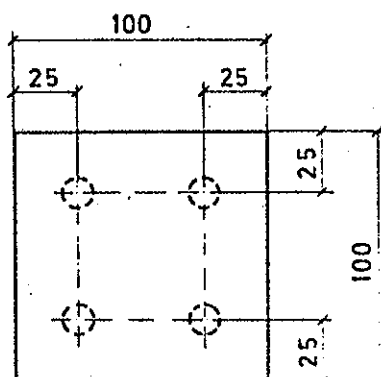

6 PROCEDURE

See NS 3251, point 2.3.

The thickness shall be measured at the four different points as shown in the figure. Length and width shall be measured 25 mm from and parallel to the edges...

8 RESULTS

The density of each test piece shall be calculated in accordance with the following formula.

$$\rho = \frac{M}{V} \text{ kg/m}^3$$

hvor

ρ is the density,

M is the mass of the test piece,
to the nearest $1 \cdot 10^{-4}$ kg.

V is the volume of the test piece,
to the nearest $1 \cdot 10^{-9}$ m³.

The density of each test piece shall be noted.

The density shall be calculated to the nearest 10 kg/m³.

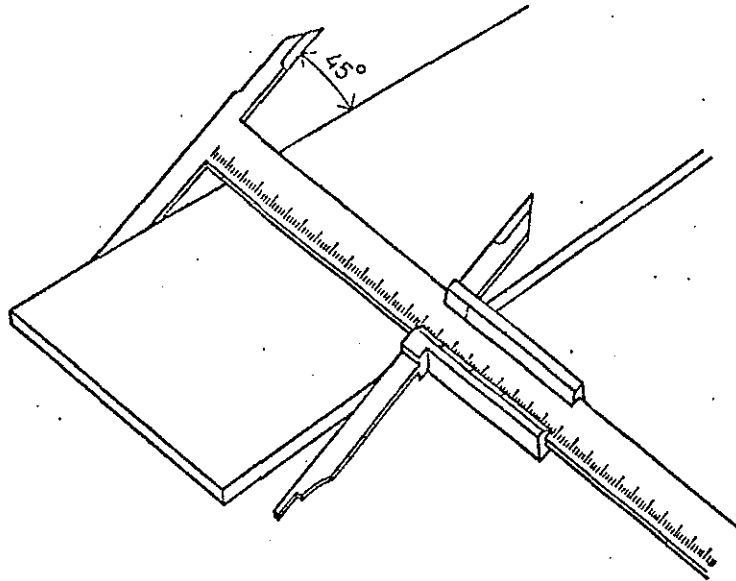

Fig. 1

COMMENTS

Information is given about quality specifications and sampling in individual product standards.

The cutting of test pieces is if needed specified in individual product standards.

INTERNATIONAL COUNCIL FOR BUILDING RESEARCH STUDIES AND DOCUMENTATION
WORKING COMMISSION W18 - TIMBER STRUCTURES

CIB TIMBER CODE

CHAPTER 5.3 MECHANICAL FASTENERS

CIB TIMBER STANDARD 06 AND 07

by

H J LARSEN

Instituttet for Bygningsteknik

Aalborg

77.01.15

PREFACE

Further to the draft for a number of chapters of CIB-Timber Code a draft is given in the following for chapter 5.3. Mechanical fasteners.

The background for the draft is the draft for the corresponding chapter in a Nordic timber code on which comments will be invited in the cause of 1977. The present draft, however, has been made more general than the Nordic draft, which only comprises structures of Nordic softwood. The special rules for these woods are given as examples.

A number of comments elaborating and explaining the proposed formulas are given in an appendix after the code text.

In a number of cases comparisons with national codes and rules have been included in the comments. However, comparisons are difficult because the safety systems are inhomogeneous and often they are not explicitly described. A further estimate of the drafts is therefore expected from the individual members of the CIB-W18.

Together with the code two standards denoted CIB-RILEM Timber Standard 06 and 07 have been prepared.

The first (No. 06) on test of mechanical fasteners has been prepared on the basis of the RILEM draft which was discussed and accepted at the CIB-W18 meeting in June 1976 (CIB-W18/paper 6-7-1, J. Kuipers), but a number of verbal alterations which have not yet been discussed by RILEM have been made. The name of CIB-RILEM Timber Standard is thus a bit incorrect.

The second (No. 07) on requirements of the timber and calculation of characteristic values has also been prepared on the basis of a draft discussed and accepted in June 1976, namely CIB-W18/paper 6-7-3, B. Norén and M. Johansen. This draft has not been finished by RILEM either.

H. J. Larsen

5.3 Mechanical fasteners

5.3.0 General

5.3.0.1 General requirements

Where asymmetric fasteners are used or where the load is eccentric consideration should be given to these factors. This applies also to the determination of the load-carrying capacities of the fasteners.

In a joint where several identical fasteners are used it can be assumed that each fastener is loaded equally. However, where a large number of fasteners are used at a joint the loading capacity of the joint can be less than the sum of the capacities of the individual fasteners.

The entire load on a joint should normally be carried by one type of fastener. In some cases, however, two types of fastener may be used provided their stiffness are the same or similar.

- : Glue and mechanical fasteners have very different stiffness properties and thus they can never be assumed to act
- : in unison.

The arrangement of timber joints and the size of the fasteners, mutual distances and distance to end or edge of the timber should be chosen so that the expected strengths can be obtained without unacceptable splitting or damage to the timber.

5.3.0.2 Determination of characteristic load-carrying capacities

The characteristic load-carrying capacities for other fasteners than those mentioned in section 5.3.1 - 5.3.4 are determined from tests carried out in conformity with the CIB-RILEM Timber Standards 06 and 07.

The load-carrying capacities given in sections 5.3.1 - 5.3.4 apply, unless otherwise stated, to permanent load and moisture classes 0 and 1, and assume that the rules given for workmanship, etc. are satisfied.

Where nothing else is stated the load-carrying capacities for other load durations and moisture classes are found by multiplication by the factors given for structural timber.

The stated load-carrying capacities apply to statical load and are reduced in some cases by fluctuating or dynamical load.

- : Attention is drawn to the fact that certain fasteners, e.g. nails, bolts without connectors and bolts with split ring
- : or shear-plate connectors, have only inferior strength and will reveal great slip when exposed to heavy stresses
- : with frequently alternating directions or vibrating load.

5.3.0.3 Requirements to protection against corrosion

Nails and screws in climate classes 0, 1, and 2 and other steel parts in climate class 0 are normally allowed to be unprotected.

- : The consideration for the finish of the structures may call for stricter rules for corrosion protection, especially
- : in climate class 2. Attention is drawn to the fact that certain woods, e.g. oak, and some treatments, e.g. fire retardant, may have a corroding effect on unprotected steel.

Furthermore, steel members in climate classes 1 and 2 should be protected against corrosion corresponding to galvanizing with a minimum thickness of 25 μ m. In climate class 3 corrosion protection should correspond to hot galvanizing with a min. thickness of 70 μ m.

5.3.1 Nails

5.3.1.1 Laterally loaded nails

Timber-to-timber joints

In joints where the following minimum timber dimensions and distances are obeyed the characteristic load-carrying capacity in N can be determined by

$$F = k_{\text{nail}} d^{1.7} \quad (5.3.1.1 \text{ a})$$

where d (in mm) is the diameter for round nails and the side length for square nails. The factor, k_{nail} , which is dependent on among other things nail type and yield moment of the nails, wood species and grade (especially the density) must be determined by tests.

: For round nails with a characteristic yield stress of at least $40(20 - d)$ MPa the following equation can be used for Nordic softwood and other woods with corresponding properties

$$k_{\text{nail}} = 120 \sqrt{\rho_{0.15}} \quad (5.3.1.1 \text{ b})$$

: where $\rho_{0.15}$ is the density of the timber corresponding to mass at a moisture content of $\omega = 0$ and volume at $\omega = 0.15$.

: For structural timber at least corresponding to T18 $\rho_{0.15} = 0.36$ and thus $k_{\text{nail}} = 72$ can be assumed.

In gusset joints with more than 10 nails in each line parallel to the direction of force only 2/3 of the load-carrying capacity of the nails in excess of 10 may be taken into account.

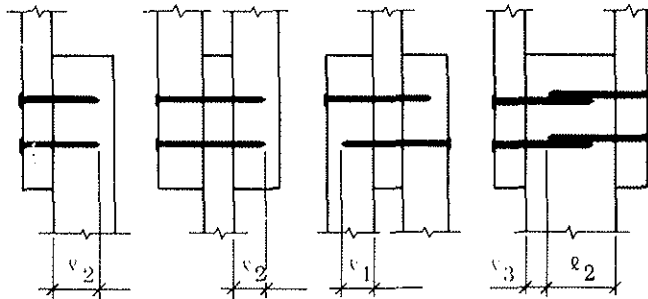

Figure 5.3.1.1 a

The values assume that the nails are driven in perpendicular to the grain, that the thinnest member has a thickness of $7d$, and that the penetration depths (including the point) satisfy the following conditions (cf. fig. 5.3.1.1 a):

Nails in double shear (driven in alternating from either side)	$l_1 \geq 8d$
Other cases	
smooth nails	$l_2 \geq 12d$
annular and spirally grooved nails	$l_2 \geq 8d$

By smaller thicknesses and lengths the load-carrying capacity is reduced proportional to the length. It is required that the nail length in any timber member is at least $5d$ and that the penetration length l_2 is at least $8d$ for smooth nails. For annular grooved nails the penetration length should at least be $4d$. If l_3 is greater than $3d$ (cf. fig. 5.3.1.1 a) nails from the two sides are allowed to touch in the middle member.

Nails in end grain should normally not be considered capable of transmitting force.

Minimum distances are given in fig. 5.3.1.1 b. Deviations of 20% are allowed provided the total number of nails is not increased. The nails should be staggered in the best possible way, for example as shown in fig. 5.3.1.1 b, one nail thickness in relation to the system lines.

A joint should contain at least 2 nails. If there are only one or two nails the values according to formula (5.3.1.1 a) are multiplied by 0.7.

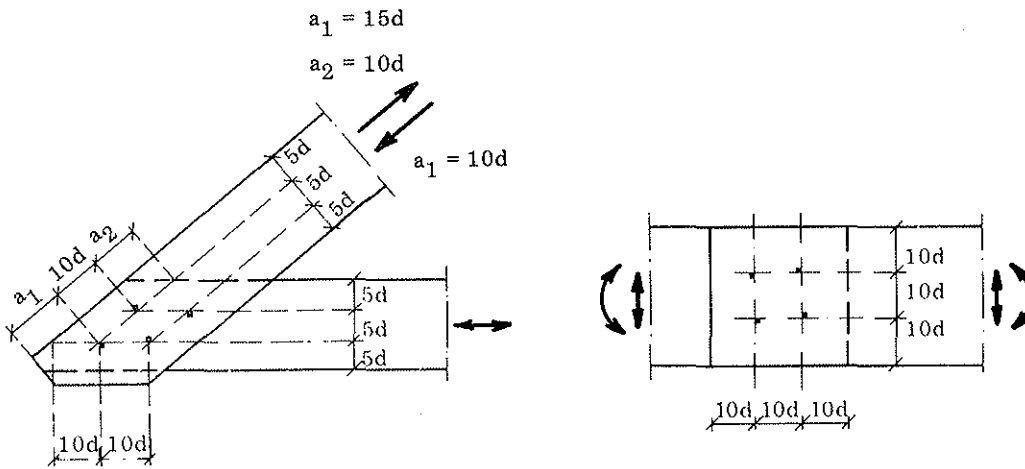

Figure 5.3.1.1 b

Steel-to-timber joints

What is stated for timber applies, but the load-carrying capacities can be multiplied by 1.25 and the distances between nails (but not to edge and end of timber) can be reduced by 30%.

Board materials-to-timber joints

What is stated for timber applies, but a board with the thickness t can be assumed to correspond to a timber member of softwood corresponding to quality T18 with the thickness

- 2.5 t for plywood of birch, beech, and similar hardwood
- 1.5 t for plywood of fir, pine, and similar softwood
- 2.0 t for plywood with plies of alternating hardwood and fir or pine (combi-plywood)
- t for structural particle board and semihard structural fibre board
- 3.0 t for hard or oil-tempered structural fibre board.

If only splitting of the timber is taken into account, the distances between nails (but not to edge or end of timber) can be reduced by 20% compared to the distances in timber-to-timber joints. The strength of the boards may require greater distances.

If for example brads are used instead of ordinary nails with heads of about 2.5 d the load-carrying capacity for semihard fibre boards is reduced by half.

5.3.1.2 Withdrawal loads of nails

The characteristic withdrawal resistance of nails in N for all moisture classes for nailing perpendicular to the grain and for slant nailing as shown in fig. 5.3.1.2 a - b is calculated as the smallest of the values according to formula (5.3.1.2 a) corresponding to withdrawal of the nail in the member receiving the point, and formula (5.3.1.2 b - c) corresponding to the head being pulled through.

$$F = \min \begin{cases} fd(\ell - \ell_p) & (5.3.1.2 a) \\ fd(h + \ell_h) & \text{for smooth nails} & (5.3.1.2 b) \\ fd\ell_h & \text{for annular and spirally grooved nails} & (5.3.1.2 c) \end{cases}$$

The length of the point is denoted ℓ_p while the equivalent timber thickness is denoted ℓ_h .

: Normally $\ell_p = 1.5d$ and the values of ℓ_h given in table 5.3.1.2 are assumed.

For spirally or annular grooved nails only the grooved part is considered capable of transmitting force. By slant nailing ℓ and h are measured as shown in fig. 5.3.1.2 b and the load-carrying capacity is calculated as if the force were parallel to the nail. Unless otherwise ensured, e.g. by pre-boring, $\alpha = 45^\circ$ is assumed.

The parameter f , dependent on among other things type of nail and timber species and grade (especially density) must be determined by tests.

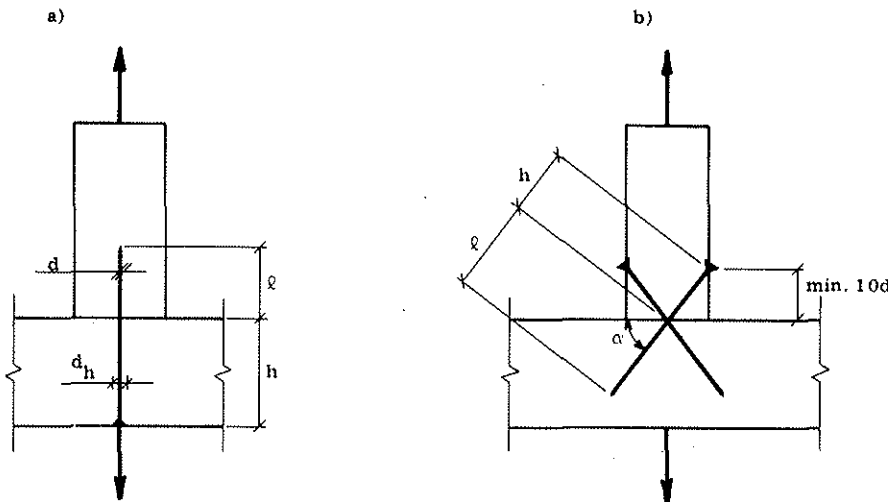

Figure 5.3.1.2

Nails in end grain should not be considered capable of transmitting force.

The distances given in section 5.3.1.1 should be obeyed and the distance to loaded edge by slant nailing should be at least $10d$, cf. fig. 5.3.2.1 b.

- : Normally the values of f given in table 5.3.1.2 can be assumed for softwood. For annular and spirally grooved
- : nails ordinary good commercial quality is assumed. Special nails will often have higher values. For T18 a charac-
- : teristic density of $\rho_{0.15} \sim 0.36$ is assumed.

Table 5.3.1.2

	f in N/mm ²		ℓ_h/d
	general	T18	
ordinary nails, round	$7.5 \rho_{0.15}^2$	1.0	36
ordinary nails, square	$9 \rho_{0.15}^2$	1.2	33
spirally grooved nails	$20 \rho_{0.15}^2$	2.6	13
annular grooved nails	$28 \rho_{0.15}^2$	3.6	10

5.3.2 Bolts and dowels

The characteristic load-carrying capacity in N per shear plane for bolts and dowels with a yield stress f_y of at least 240MPa (corresponding to ISO grade 4.6) is the smallest value found by the formulas (5.3.2 a) - (5.3.2 e).

$$F = \min \begin{cases} 10\rho_{0.15}(k_1 h_1 + k_2 h_2)d & \text{(only for two-member joints)} & (5.3.2 a) \\ 25\sqrt{\rho_{0.15}} d^2 + 7\rho_{0.15} k_1 h_1 d & & (5.3.2 b) \\ 40 \rho_{0.15} k_1 h_1 d & & (5.3.2 c) \\ 20\rho_{0.15} k_2 h_2 d & \text{(only for three-member joints)} & (5.3.2 d) \\ 45d^2 \sqrt{\rho_{0.15}} \sqrt{(k_1 + k_2)/2} \sqrt{f_y/240} & & (5.3.2 e) \end{cases}$$

where

h is timber thickness in mm

d is the diameter in mm

k is a factor, obtained from table 5.3.2, taking into consideration the influence of the angle between force and grain direction.

In three-member joints subscript 1 denotes side member and subscript 2 denotes middle member.

In two-member joints the subscripts are chosen so that $k_1 h_1 \leq k_2 h_2$.

Table 5.3.2 Factor $k(k_1, k_2)$ in calculation of the load-carrying capacity of bolts, dowels and screws

Angle between force and grain direction	Diameter d(mm)		
	6	12	24
0°	1	1	1
30°	1	0.88	0.82
45°	1	0.76	0.70
60°	1	0.70	0.58
90°	1	0.64	0.52

: For softwood at least corresponding to T18 (i.e. $\rho_{0.15} = 0.36$) the following is found by inserting into (5.3.2 a) - (5.3.2 e):

$$F = \min \begin{cases} 3.6(k_1 h_1 + k_2 h_2)d & \text{(only for two-member joints)} & (5.3.2 f) \\ 15d^2 + 2.5k_1 h_1 d & & (5.3.2 g) \\ 14.4k_1 h_1 d & & (5.3.2 h) \\ 7.2k_2 h_2 d & \text{(only for three-member joints)} & (5.3.2 i) \\ 27d^2 \sqrt{(k_1 + k_2)/2} \sqrt{f_t/240} & & (5.3.2 j) \end{cases}$$

Minimum distances are given in fig. 5.3.2. The distance from bolt or dowel to loaded end can be reduced from 7d to 4d provided the load is reduced correspondingly. If the load-carrying capacity is assumed to be higher than corresponding to formula (5.3.2 e) with $f_y = 240\text{MPa}$ the distance in the grain direction should be increased correspondingly.

The stated distances to loaded edge are not always adequate to prevent splitting when the bolts are fully utilized. When the force acts at an angle to the grain it should therefore be shown that the force can be sustained without splitting.

: Where a detailed analysis is not carried out, this can be proved by showing that $Q \leq 2f_v b_e h/3$, where Q is the shear force produced by the bolt or dowel, h is the thickness in mm of the member, and b_e is the distance in mm from loaded edge to the farthest point of the bolt.

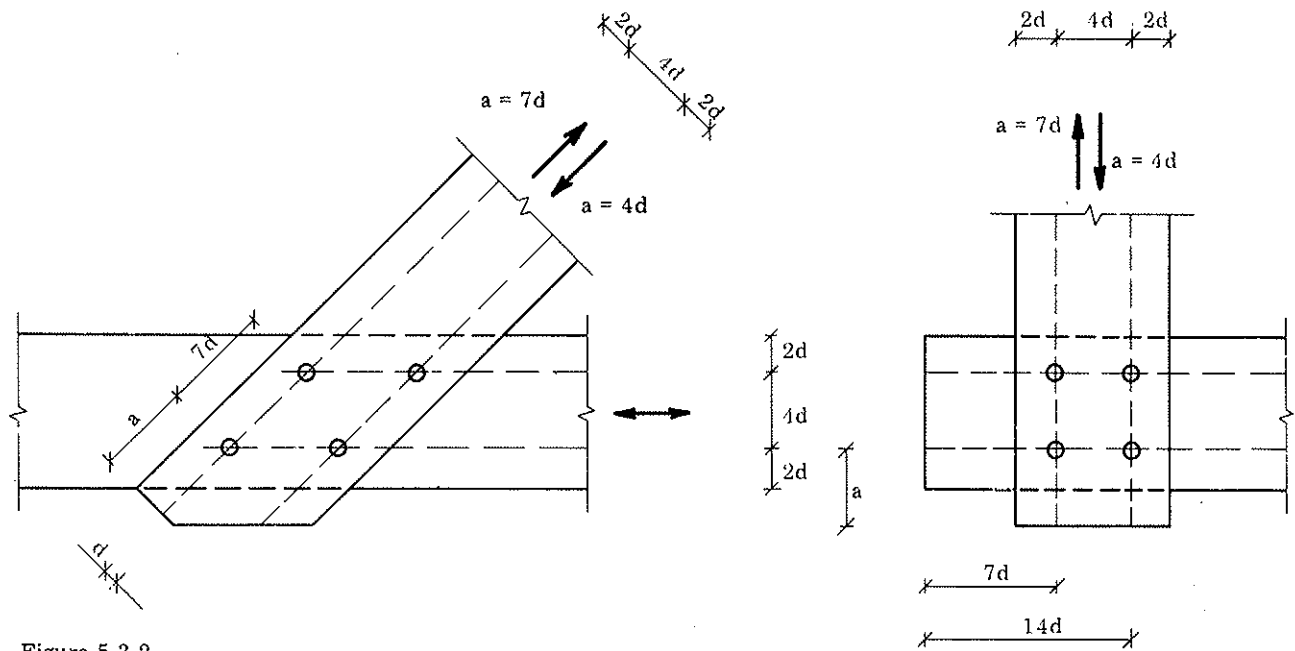

Figure 5.3.2

In multiple shear the load-carrying capacity can be found by considering the structure as a number of three-member joints.

Where the side members are steel plates the above formulas can be used putting h_1 equal to h_2 equal to the thickness of the wood member.

Where the middle member is a steel plate formula (5.3.2 b) is omitted and the values of the formulas (5.3.2 d) and (5.3.2 e) can be multiplied by 1.4.

5.3.3 Screws

5.3.3.1 Laterally loaded screws

Timber to timber

The characteristic load-carrying capacity in N of screws with a yield stress f_y of at least 240 MPa screwed at right angles to the grain is the smallest of the values from the formulas (5.3.3.1 a) - (5.3.3.1 c)

$$F = \min \begin{cases} 40 \rho_{0.15} k_1 h d & (5.3.3.1 a) \\ 25 \sqrt{\rho_{0.15}} d^2 + 7 \rho_{0.15} k_1 h d & (5.3.3.1 b) \\ 45 d^2 \sqrt{\rho_{0.15}} \sqrt{(k_1 + k_2)/2} \sqrt{f_y/240} & (5.3.3.1 c) \end{cases}$$

where

- h is the thickness in mm of the timber,
- d is the diameter in mm of the screw, measured on the smooth shank,
- k_1, k_2 are factors, obtained from table 5.3.2, taking into consideration the influence of the angle between force and grain direction in the member under the screw head (k_1) and the member receiving the point (k_2).

: For softwood at least corresponding to T18

$$F = \min \begin{cases} 14.4 k_1 h d & (5.3.3.1 d) \\ 12 d^2 + 3 k_1 h d & (5.3.3.1 e) \\ 27 d^2 \sqrt{(k_1 + k_2)/2} \sqrt{f_y/240} & (5.3.3.1 f) \end{cases}$$

: is found by inserting $\rho_{0.15} = 0.36$ into (5.3.3.1 a) - (5.3.3.1 c).

In the expressions it is assumed that the mutual minimum distances and to end and edge given for bolts are obeyed, that the length of the smooth shank is greater than or equal to the thickness of the member under the screw head, and that the penetration depth of the screw, i.e. the length in the member receiving the point, is at least $8d$.

If the penetration depth is less than $8d$ the load-carrying capacity is reduced proportionally. However, the penetration depth should be at least $5d$. Screws in end grain should normally not be considered capable of transmitting force.

Steel to timber

The characteristic load-carrying capacity in N is (cf. formula (5.3.3.1 c))

$$1.4 \cdot 45 \sqrt{\rho_{0.15}} \sqrt{(1 + k_2)/2} \sqrt{f_y/240} \quad (5.3.3.1 g)$$

and furthermore, what is stated for timber-to-timber joints applies.

5.3.3.2 Withdrawal loads of screws

The characteristic withdrawal strength in N of screws screwed at right angles to the grain is

$$F = (f_0 + fd)(\ell_g - d) \quad (5.3.3.2 a)$$

where

d is the diameter in mm measured on the smooth shank,

ℓ_g is the threaded length in mm in the member receiving the screw,

f_0 and f are parameters dependent on among other things the shape of the screw and timber species and grade.

: For screws according to Swedish Standard SMS R 1573-1575 or 1576 or similar the following can be assumed for softwood at least corresponding to T18

$$F = (18 + 7d)(\ell_g - d) \quad (5.3.3.2 b)$$

It is assumed that the minimum distances and penetration lengths given for laterally loaded screws are obeyed and that the strength of the screw is sufficient.

5.3.4 Bolted and screwed connected joints

Generally, the characteristic load-carrying capacity is composed of a contribution F_B from the bolt (or screw), calculated as stated in section 5.3.2, and a contribution F_C from the connector. F_C is determined as follows:

The characteristic load F_{B+C} for bolt (screw) and connector is determined as stated in section 5.3.0. The characteristic load for the connector F_C is then determined by

$$F_C = F_{B+C} - F_B \quad (5.3.4)$$

where F_B is determined by tests or as given in section 5.3.2.

If a connector is to be used together with several bolt diameters the investigation should comprise at least maximum and minimum bolt diameter.

: For characteristic load-carrying capacities of different types of connector, type approvals, etc. are referred to.

The rules valid for bolts, e.g. with regard to minimum distances, should be obeyed. Besides, the minimum distances given in table 5.3.4 apply.

Table 5.3.4 Minimum distances for connectors

D is the diameter of the connector or side length in actual direction	Toothed plates		Other connectors
	Round	Square	
Centre to centre			
in grain direction	1.25 D	1.50 D	2.00 D
at right angles to grain direction	1.20 D	1.20 D	1.30 D
Centre to end			
in grain direction	1.25 D	1.50 D	1.75 D
Centre to edge			
at right angles to grain direction	0.60 D	0.70 D	0.80 D

The distance to end may in joints with a single bolt be reduced to D provided the load-carrying capacity is reduced correspondingly.

If the total height of the connector is denoted h, minimum thickness of the side members is h for toothed-plate connectors, for single-sided toothed plates, however, 2h, and 1.5h for other connectors. For middle members the minimum thickness is 1.5h for toothed-plate connectors and 2h for connectors in grooves.

The stated distances to edge are not always adequate to prevent splitting at maximum load. When the force acts at an angle to the grain direction it should therefore be proved that the force can be sustained without causing splitting of the timber.

- : Where a detailed analysis is not carried out this can be proved by showing that $Q \leq 2f_vhb_e/3$, where h is the thickness of the member and l_e is the distance from loaded edge to farthest edge of the connectors, cf. fig. 5.3.4.

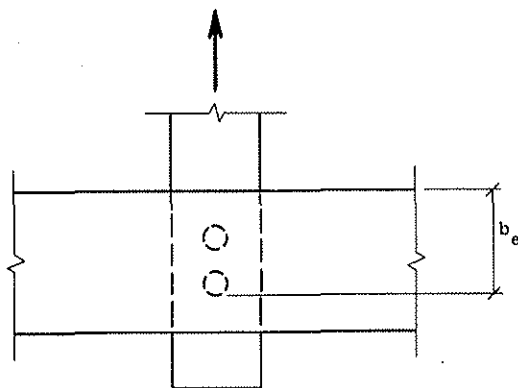

Fig. 5.3.4

5.3.5 Construction rules

The fasteners should be placed in conformity with the drawings. The min. distances etc. given in section 5.3.1 - 5.3.4 should be obeyed with the given tolerances.

In the joints wane, knots or other defects are not allowed in such degree that it reduces the load-carrying capacity of the joints.

Unless otherwise stated nails should be driven in at right angles to the grain and to such depth that the surface of the nail heads flushes with the timber surface.

Unless otherwise stated slant nailing should be carried out in conformity with fig. 5.3.1.2 a.

Bolts should fit tightly into the pre-bored holes. Washers with a length and thickness of at least $3d$ and $0.3d$, respectively (d is the bolt diameter), should be used under the head and nut.

The bolts should be tightened so that the members fit closely, and they should be tightened up if necessary when the timber has reached its equilibrium moisture content.

At least 2 dowels should be used in a joint. The minimum dowel diameter is 8 mm. Turned dowels should be used and the pre-bored holes in timber members should have a diameter which is 0.2 - 0.5 mm less than the dowel diameter while the pre-bored holes in steel plates should have the same diameter as the dowel. The dowels should be at least $2d$ longer than the total thickness of the joint.

For screws pre-boring to the full length of the screws should be carried out. The diameter of the pre-bored hole should be equal to d for the smooth shank and 0.9-1.0 times the core diameter for the threaded length. Washers are used as stated for bolts.

Through the centre of each connector a bolt or screw for which the above rules are valid should be placed.

Connectors should fit tightly in the grooves.

When using toothed plates the teeth should be completely pressed into the timber. In smaller and lighter structures the bolt may be used for impressing provided it has at least 16 mm diameter. The washer should then have at least the same side length as the connector and the thickness should at least be 0.1 times the side length. It should be carefully checked that the bolt has not been damaged in tightening.

- : Impressing should normally be carried out with special press tools or special clamping bolts with washers large and
- : stiff enough to protect the timber from damage.

APPENDIX - COMMENTS

C 5.3.0 General

The draft is made very general.

The load-carrying capacity expressions have been exemplified for Nordic softwood of a quality denoted T18 which signifies that the characteristic bending strength (short-term load, moisture class 1) is 18 MPa. It is assumed that the grade EC-2 will be thus determined that it satisfies the requirements of T18.

C 5.3.0.2 Deformation of characteristic load-carrying capacities

The strength of a joint depends on f_c^α , where $0 \leq \alpha \leq 1$. Only for $\alpha = 1$ the factor taking into account load duration and moisture class will be the same as for timber. However, for practical reasons the same factor is proposed. The values for permanent load and moisture class 1 in the following sections have been chosen so this rule is on the safe side.

C 5.3.1.1 Laterally loaded nails

The load-carrying capacity can be composed of two main contributions, namely dowel effect and friction.

Due to moisture deformations a gap between the timber members should normally be assumed so that the friction contribution will only be of importance at deformations so large that it cannot be utilized in practice.

Tests, cf. e.g. Larsen [1] and [2], have shown that the dowel contribution P_y for slender nails can be determined with good approximation as

$$P_y = \sqrt{2M_y f_H d} \quad (1)$$

where

M_y is the yield moment,

f_H is the impression strength, and

d is the diameter (round nails) or side length (square nails).

If the yield stress of steel is denoted f_y , we have $M_y = k_1 d^3 f_y$, where k_1 depends on the cross-section (e.g. square/round) of the nail. The impression strength can be assumed proportional with the prism strength, which again can be assumed proportional with the density, e.g. $\rho_{0.15}$ (mass at moisture content $\omega = 0$ and volume at $\omega = 0.15$). Thus, $f_H = k_2 f_c = k_3 \rho$ can be assumed.

The load-carrying capacity can thus be expressed as

$$P_y = k_4 d^2 \sqrt{\rho f_y} \quad (2)$$

The yield stress f_y is not a constant for a given steel but depends on among other things the ratio between d and the diameter of the wire, from which the nail has been cold-drawn, a ratio which varies very much. However, the general tendency is that f_y decreases with increasing d . The general tendency is the same for k_2 and k_3 . This can be taken into consideration by replacing (2) with

$$P_y = k_{\text{nail}} d^\alpha \sqrt{\rho_{0.15}} \quad (3)$$

where $\alpha < 2$. The factor k depends on nail material, wood species, etc.

- [1] LARSEN, H. J. Determination of load-slip curves for bolts and nails. Aalborg University Centre. Pure and Applied Mechanics, Report R 7501. (Comparison of tests carried out by among others Aune, Booth, Brock, Kuenzi, Mack, Meyer, Möhler and Wilkinson).
- [2] LARSEN, H. J.: K. W. Johansen's tests on nailed joints. Byggningsstatistiske Meddelelser No. 1, 1977 (not yet available).

The condition for the above is that we are dealing with slender nails, meaning that the length, ℓ , in the individual members should be greater than a minimum value, ℓ_{\min} , which is $8d - 12d$, greatest when f_y/f_c is relatively large, i.e. strong nails in weak timber. The necessary length can be reduced a little in the member under the nail head.

If the length is smaller than ℓ_{\min} the load-carrying capacity will theoretically be decreased proportional with the length.

In their tests Stoy & Mlynek [3] did not find the dependence (2) between P_y and f_y , but that P_y rapidly became independent of f_y . The reason was that the geometry of the joints was maintained and that the timber thicknesses for the higher values of f_y were quite insufficient to ensure the rupture form corresponding to (2).

For three- or multiple-member joints the load-carrying capacity can be found by adding up the load-carrying capacity in the individual shear planes. In his tests Brock [4] found a load-carrying capacity which was only 90% of this. The reason was that the timber dimensions in three-member joints were below ℓ_{\min} .

As suggested by Brock the British Timber Code states that the load-carrying capacity should be assumed proportional to ρ , but indeed Brock's tests do not verify this assumption, they give a linear relationship, not a proportionality. An expression of the form $\rho^{0.5}$ fits just as well as the assumed proportional relationship.

The values suggested for timber grade T18 have in the following table been compared with DIN 1052 assuming the safety factor equal to 1.5 and with CP 112, group J3, with the safety factor 1.8.

Characteristic values in N

d(mm)	Proposed	DIN 1052	CP 112
2	230	250	160
3	470	520	370
4	760	860	650
5	1110	1250	1020
6	1510	1690	1470

C 5.3.1.2 Withdrawal loads of nails

According to tests carried out in USA, CP 112 assumes that f is proportional with $\rho_{0.15}^{2.5}$, but a number of E. George Stern's tests indicate that $\rho_{0.15}^2$ is a better assumption. As a comparison with the values given it can be mentioned that $f = 1.6$ has been assumed in CP 112 for group J3, corresponding to T18 and round nails. In DIN 1052 $f = 1.9$ has been assumed. When the moisture content is changed significantly f is reduced to 0.40 (CP) or 1.3 (DIN), respectively. For »improved nails» $f = 2.4$ is assumed in CP 112.

C 5.3.2 Bolts and dowels

The proposed expressions are generalizations and simplifications of the theoretical expressions given in Larsen [5]. It has been assumed that the impression strength for the timber is proportional to the density.

- [3] STOY, W., MLYNEK, F. Versuche über der Nagelfestigkeit und der Holzfestigkeit auf die Widerstandsfähigkeit von genagelten Holzverbindungen. Fortschritte und Forschungen im Bauwesen, Heft 20, 1955.
- [4] BROCK, G. R. The strength of nailed joints. Forest Products Research Bulletin No. 41, London 1957.
- [5] LARSEN, H. J. The yield load of bolted and nailed joints. IUFRO-5, South Africa 1973, p. 646-654.

The proposed values have in the following been compared with DIN 1052 and CP 112.

Characteristic values in kN

d (mm)	h_1 (mm)	h_2 (mm)	v	Proposed	DIN 1052	CP 112
10	28	25	0	1.8	1.5	2.7
			90	1.6	1.1	1.7
	32	63	0	2.3	1.9	2.7
			90	2.1	1.4	2.1
20	38	38	0	5.5	4.6	9.4
			90	4.2	3.4	3.6
	100	100	0	10.8	10.2	10.9
			90	7.5	7.7	6.8

By evaluation of the values it should be noted that the allowed increase at short-term load is greater in the proposal than according to both of the investigated codes.

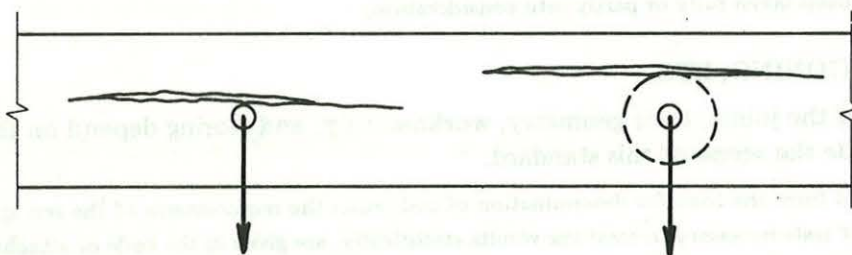

The additional rule for load applied at an angle to the grain is just the usual requirement of shear strength expressed for the part of the beam created if the beam cracks at the bolt hole, cf. the above figure.

The rule has been evaluated in connection with the preparation of the Nordic draft timber code - e.g. from tests carried out by Nielsen & Johansen [6]. The stresses were calculated by the use of a finite-element programme for anisotropic elastic materials.

The conclusion of the investigation was:

The calculated tensile stresses indicate that a design on the basis of tensile stresses perpendicular to the grain is possible.

However, lack of knowledge of the long-term strength for timber stressed in tension at right angles to the grain will demand that laboratory tests are carried out together with the numerical tests.

C 5.3.3.1 Laterally loaded screws

The same expression as for bolts has been used. Theoretically, this is in certain cases a little on the unsafe side due to the reduced yield moment in the grooved part.

However, it is found reasonable because slips can only occur in the hole in one of the members and because the gap between the timber members will normally be smaller than by bolts.

C 5.3.4 Withdrawal loads of screws

The expression according to DIN 1052 corresponding to (5.3.3.2 b) reads $F = 4.5 d l g$, while the rules in CP 112 correspond to approximately $5.5 d l g$. The screw shapes in the different countries may differ.

Lehrstuhl für
Ingenieurholzbau u. Baukonstruktionen
Universität (TH) Karlsruhe
Prof. Dr.-Ing. K. Möhler

[6] NIELSEN, T. FELDBORG, JOHANSEN, M. Forsøg med træforbindelser med bolte og mellemlæg (Investigation of timber joints with bolts and connectors. Danish Building Research Institute, Report No. 67, 1970.

CIB - RILEM TIMBER STANDARD*

INTERNATIONAL COUNCIL FOR BUILDING RESEARCH STUDIES AND DOCUMENTATION
* CONSEIL INTERNATIONAL DU BÂTIMENT

No. 06	Subject: TEST OF MECHANICAL FASTENERS - TEST METHOD FOR SHORT-TERM TESTING	Draft No. Date: 1 76.08.0 2 76.08.31 3 76.11.0'
------------------	--	--

1. SCOPE

The present standard lays down a test method for determining the mechanical properties - ultimate load and deformation properties - for timber joints with mechanical fasteners, so that test results for different joints and from different testing institutions will be comparable.

- : To utilize testing of timber joints in the best possible way irrespective of the actual purpose of the testing, it
- : should be carried out in conformity with the rules of this standard, unless it is incompatible with the purpose
- : of the investigation. In such cases the deviations should be reduced to a minimum.

2. AREA OF APPLICATION

The standard applies to joints in statically loaded structures.

- : Dynamic effects can be expected when the load varies with time with a frequency exceeding 0.5 - 0.6 times the
- : natural frequency of the structure.
- : It is not possible to state exactly when a structure can be assumed statical and when it must be treated as dy-
- : namically loaded, because, among other things, in the determination of loads or stiffness requirements in the
- : code the dynamic effects have been taken fully or partly into consideration.

3. TEST SPECIMENS, CONDITIONING, ETC.

Requirements of the materials of the joints, their geometry, workmanship, and storing depend on the purpose of the tests and is outside the scope of this standard.

- : In cases where the testing should form the basis for determination of code rules the requirements of the test spe-
- : cimens, including the number of tests necessary to treat the results statistically, are given in the code or attached
- : standards. These may be general requirements or requirements which are special for the joint type in question
- : or the purpose of the investigation.

4. EQUIPMENT

In addition to equipment for measuring the geometry of the test specimens, moisture content, etc. the following are assumed to be available:

A testing machine able to apply the necessary load as prescribed in section 5 and with a recording equipment able to measure the load with 1% accuracy.

Equipment to measure the mutual displacements with an accuracy better than 1%, for displacements less than 2 mm, however, 0.02 mm. The equipment should ensure that eccentricities, twist, etc. have no influence on the measurings.

Equipment, which can continuously record coherent values of loads and displacements, is recommended. Exceptionally, it can be accepted that the displacements are only measured at chosen load levels provided the measurings can be carried out without influencing the continuity of the load application significantly.

5. LOAD APPLICATION AND SLIP MEASURINGS

5.1

The loading procedure as shown in fig. 1 should be used. The applied load is denoted F . F_{est} is the expected maximum load. The stated rates of loading, etc. should be obeyed with a tolerance of $\pm 50\%$.

* The standard is prepared on the basis of a proposal from RILEM 3TT-Committee to CIB-W18, which was discussed and adopted in June 1976.

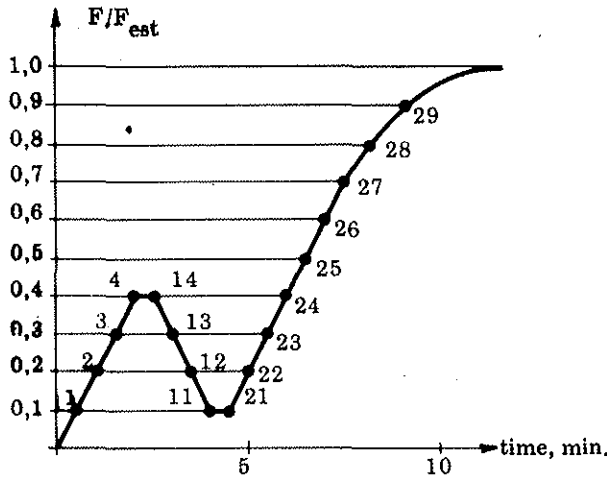

Fig. 1

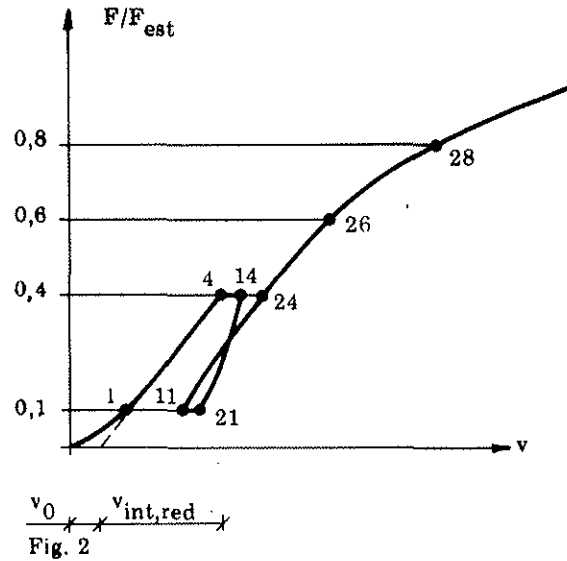

Fig. 2

Initially the load is applied at a constant rate of $0.2 F_{est}$ per minute up to $0.4 F_{est}$, which is maintained for 30 seconds, whereupon it is diminished at the same rate to $0.1 F_{est}$, which is also maintained for 30 seconds. Then the load is increased again. Up to $0.7 F_{est}$ the load is increased at a constant rate corresponding to $0.2 F_{est}$ per minute. Above $0.7 F_{est}$ a constant deformation rate is used so that the ultimate load is reached in 3-5 minutes' additional testing time (total testing time 10-15 min.).

When the displacements reach 15 mm the test can be interrupted even if the ultimate load has not been reached.

5.2

F_{est} is estimated from e.g. experience, preliminary tests or calculations.

Should it be proved during the execution of the tests that the mean value of the maximum load of the tests already executed deviates more than 20% from the estimated value, F_{est} should be adjusted correspondingly for the following tests. The already determined values of the ultimate load are accepted without adjustment as part of the final results.

5.3

The displacements, v , should be measured at intervals of load not less than $0.1 F_{est}$, and from coherent values of load and displacement a load-slip curve can be drawn, cf. fig. 2.

5.4

The load-carrying capacity of the joint F_{ult} is assumed to be the maximum load obtained for displacements less than or equal to 15 mm.

5.5

In the cases where the properties of the joint are to be described by a few numbers the choice should primarily be among the following:

ultimate load	F_{ult}
initial displacement	$v_{int} = v_4$
reduced initial displacement	$v_{int,red} = 4(v_4 - v_1)/3$
joint slip	$v_0 = v_{int} - v_{int,red}$
elastic displacement	$v_e = 10((v_{14} + v_{24}) - (v_{11} + v_{21}))/6$
slip modulus	$0.4 F_{est}/v_{int,red}$
displacement at 60% load ($F/F_{ult} = 0.6$)	v_{60}
reduced v_{60}	$v_{60,red} = v_{60} - v_{24} + v_{int,red}$
displacement at 80% load ($F/F_{ult} = 0.8$)	v_{80}
reduced v_{80}	$v_{80,red} = v_{80} - v_{24} + v_{int,red}$

If the difference between F_{ult} and F_{est} made it necessary to adjust F_{est} , the values used to calculate the displacements mentioned are adjusted on the basis of the load-slip curve. In each case v_{60} and v_{80} are determined corresponding to the actual F_{ult} .

6. TEST REPORT

The test report should contain all relevant information available on test specimens, test procedure and test results, among others:

- wood species and quality, relevant strength parameters and in each case relative density,
- material, quality and strength properties of the fasteners, including any protection against corrosion,
- drawings of the joints stating among others, dimensions and number of fasteners,
- conditioning of the timber and its moisture content prior to execution of the joints, storing until testing, gaps between members, fissures, etc, and the moisture content during testing,
- test equipment,
- the load procedure used by reference to this standard with statement of any deviations,
- the individual test results, including mode of failure, average values, standard deviation, and any other relevant statistical data.

CIB - RILEM TIMBER STANDARD*

CONSEIL INTERNATIONAL DU BÂTIMENT * INTERNATIONAL COUNCIL FOR BUILDING RESEARCH STUDIES AND DOCUMENTATION

No. 07	Subject: TESTING OF MECHANICAL FASTENERS - REQUIREMENTS OF THE TIMBER AND CALCULATION OF CHARACTERISTICAL VALUES	Draft No. Date: 1 76.08.11 2 76.08.31 3 76.11.01
----------------------	--	---

1. SCOPE AND CONTENTS

The present standard lays down the requirements of the timber and any adjustments of test results in order that the results for short-term tests with mechanical fasteners can be used to determine characteristic code values.

Two methods, which can be considered equally acceptable are given.

By method 1 the requirements of the timber have been determined so that the test results can be applied immediately to determine the characteristic values. By method 2 the test results must be adjusted according to given rules, before they can be used in the determination of characteristic values.

Furthermore, the standard determines how the test specimens should be conditioned to correspond to the climate classed stipulated in the code, and in principle it gives guidelines for conversion from one climate class to another.

The code does not deal with the geometry and workmanship of the test specimens or for which type of loading they should be tested. This information is given by current timber codes or the standards derived for the different joints, such as:

CIB-RILEM-Timber Standard 07.w: Laterally loaded nailed joints.

CIB-RILEM-Timber Standard 07.x: Laterally loaded bolted, dowelled and screwed joints.

CIB-RILEM-Timber Standard 07.y: Laterally loaded bolted and screwed joints with timber connectors.

CIB-RILEM-Timber Standard 07.z: Joints with nail plates.

The code does not deal with the loading procedure. This procedure is assumed to be in conformity with CIB-RILEM-Timber Standard 06: Testing of mechanical fasteners. - Test method for short-term testing.

2. SYMBOLS

P load

c power, cf. (1)

f_c compressive strength

ρ relative density (mass corresponding to $\omega = 0$ and volume to moisture content ω)

ω moisture content

Indices: adj adjusted

k characteristic

lim limit

m mean value

obs observed

theor theoretical.

3. REQUIREMENTS OF THE TIMBER

3.0 General

The timber should be free from knots, which might influence the load-carrying capacity of the joints.

* The standard is prepared on the basis of a proposal from RILEM 3TT-Committee to CIB-W18, discussed and adopted in June 1976.

3.1 Method 1

If the grading rules contain special density requirements so that the characteristic density is ρ_k the timber should be, or must be, (depending on whether it is a recommendation or requirement) selected so that the following requirements are satisfied:

Mean value $\rho_m \leq 1.15 \rho_k$

At least 20% have $\rho \leq \rho_k$

If the grading rules do not contain special density requirements, $\rho_k = 0.36$ is assumed.

: It is assumed that the density is normally distributed with a coefficient of variation of 0.15.

3.2 Method 2

The timber should be, or must be, (depending on whether it is a recommendation or requirement) selected so that the density variation is as small as possible, i.e. no individual value deviates more than 10% from the mean value.

If the grading rules do not contain special density requirements the mean value should be between $0.9 \cdot 0.4$ and 0.44 .

If the grading rules contain special density requirements so that the characteristic density is ρ_k the mean value should be between $1.05 \rho_k$ and $1.25 \rho_k$.

4. CONDITIONING

If the test results are to be used directly to determine characteristic values corresponding to the climate classes given in the CIB-Timber Code, the test specimens should - unless otherwise stated - be conditioned at room temperature and the following relative humidity until equilibrium is reached:

Climate class 1: relative humidity ≥ 0.60

Climate class 2: relative humidity ≥ 0.80

5. ADJUSTMENT OF TEST RESULTS

5.1 Timber selected according to method 1

No adjustment is made apart from those for moisture content, cf. section 5.3.

5.2 Timber selected according to method 2

The calculation is based on adjusted test values P_{adj} , calculated from the measured values, P_{obs} , as

$$P_{adj} = P_{obs} \left(\frac{\rho_k}{\rho} \right)^c \quad (1)$$

ρ is the density of the timber for the joint in question.

The power $c (1 \geq c \geq 0)$ is determined on the basis of tests or an accepted theory of the load-carrying capacity of the joints. Otherwise $c = 1.0$ is used.

If there is a limit for the density ρ_{lim} above which the influence of the density can be neglected, ρ_{lim} is inserted in equation (1) instead of ρ , provided $\rho_{lim} < \rho$.

- : The basis of the adjustment method is that the strength is depending on the density. Instead of adjustment on
- : the basis of density the adjustment depending on mode of failure can be made on the basis of other parameters,
- : e.g. compressive strength or shear strength.

Adjustments, if any, for moisture content should be made as stated in section 5.3.

Unless other correlation has been determined the following relation between the compressive strength and density and moisture content should be assumed.

$$f_c = 95 \rho (2 - \omega / 0.15) \text{ N/mm}^2 \quad (2)$$

provided the moisture content ω is between 0.12 and 0.16.

5.3 Adjustment for moisture content, etc.

Conversion to other conditions than the test conditions, e.g. regarding moisture content, should be carried out in conformity with the code rules, unless others can be shown to be more correct by tests.

The conversion factors should be applied to the calculated characteristic values or - if it can be shown to be more correct - to the individual test results.

6. CALCULATION OF CHARACTERISTIC VALUES

6.0 General

On the basis of the actual test results or the adjusted ones, the characteristic values are calculated by recognized statistical methods in accordance with the code rules.

6.1 Application of numerical methods

If a theory is available of the relationship between the theoretical load-carrying capacity, P_{theor} , and parameters representing relevant properties, C , of the fastener and, T , of the timber, i.e.

$$P_{\text{theor}} = f(C, T) \quad (3)$$

the characteristic strength P_k for given material qualities C_k and T_k can be calculated as

$$P_k = \varphi_k P_{k,\text{theor}} \quad (4)$$

where

$$P_{k,\text{theor}} = f(C_k, T_k) \quad (5)$$

and φ_k is the characteristic value of the ratio $\varphi = P_{\text{obs}}/P_{\text{theor}}$ for the individual joints.

CIB-W18/7-106-1

INTERNATIONAL COUNCIL FOR BUILDING RESEARCH STUDIES AND DOCUMENTATION

WORKING COMMISSION W18 - TIMBER STRUCTURES

TIME AND MOISTURE EFFECTS

by

CIB-W18/IUFRO 55.02-03 WORKING PARTY

STOCKHOLM, SWEDEN - FEBRUARY/MARCH 1977

Meeting of Working Party - CIB W18/IUFRO S5.02-03 - "Time and Moisture Effects"

Norsk Treteknisk Institutt, Oslo, Norway.

18th - 19th November, 1976.

Participants:

DENMARK

P. Hoffmeyer Technical University, Copenhagen

FINLAND

U. Saarelainen Technical Research Centre of Finland, Helsinki

HOLLAND

H. Ploos van Amstel Technische Hogeschool, Delft

NORWAY

P. Aune The Norwegian Institute of Technology, Trondheim

(1) N. I. Bovim Norsk Treteknisk Institutt, Oslo

(2) O. Brynildsen Norsk Treteknisk Institutt, Oslo

M. Foslie Norsk Treteknisk Institutt, Oslo

SWEDEN

B. Norén Svenska Träforskningsinstitutet, Stockholm

UNITED KINGDOM

W. T. Curry BRE, Princes Risborough

(1) Secretary CIB W18/IUFRO S5.02-03

(2) Co-ordinator CIB W18/IUFRO S5.02-03 and Chairman for Meeting

Absent members of the subgroup:

GERMANY

K. Möhler Universität Karlsruhe (TH), Karlsruhe

HOLLAND

J. Kuipers Technische Hogeschool, Delft

1. Introduction

At the meetings of CIB W18 and IUFRO S5.02-00 in Denmark 1976 it was decided to set up a subgroup dealing with "Time and Moisture Effects".

This is the first meeting of the subgroup.

2. Terms of reference

The following suggestion to terms of reference had been presented:

"To study the effect of load duration and moisture contents on the probability of a timber structure reaching a limit state at any moment of its life time, and to make recommendations for implementation of the results into the CIB Timber Code."

The meeting found this too ambitious for the time being and suggested the following for the next three years:

"To study the influence of moisture contents on the strength and different stress levels on the time-to-failure for European pine and spruce."

The group should regard itself as a permanent European body for time effect problems. The group should further work on time effects of mechanical and glued joints, as well as components and complete structures.

3. Theories, assumptions, hypotheses

The following statements were referred:

"Strength loss with time is a function of stress level and short term strength. Strength loss with increasing moisture contents is negligible for timber with low short term strength." (Borg Madsen, 1976)

"Loading of full size structural specimens in bending and in tension parallel to grain for long duration at higher stress levels than allowable design stress has no apparent or measurable effect on short term test strength, provided that the load-time history does not include tertiary creep." (Strickler, Pellerin, Martin, 1976)

"Time to failure can be estimated based on a visco-elastic model calculation of the time dependent accumulated elastic potential during given mechanical excitations. The approach suggested seems promising enough to attempt quantitative verification and development of more accurate methods to calculate the elastic potential based on nonlinear viscoelastic model theory." (Lars Bach, 1973).

The group stated that for the time being no theory or model could substitute a testing of structural timber and components.

To develop an applicable theory could be a long term aim for the group.

4. Research programmes

- a) The group recommended to start working on long term effects by spot-checking the validity of Madsen's conclusions as expressed through the P-surface:

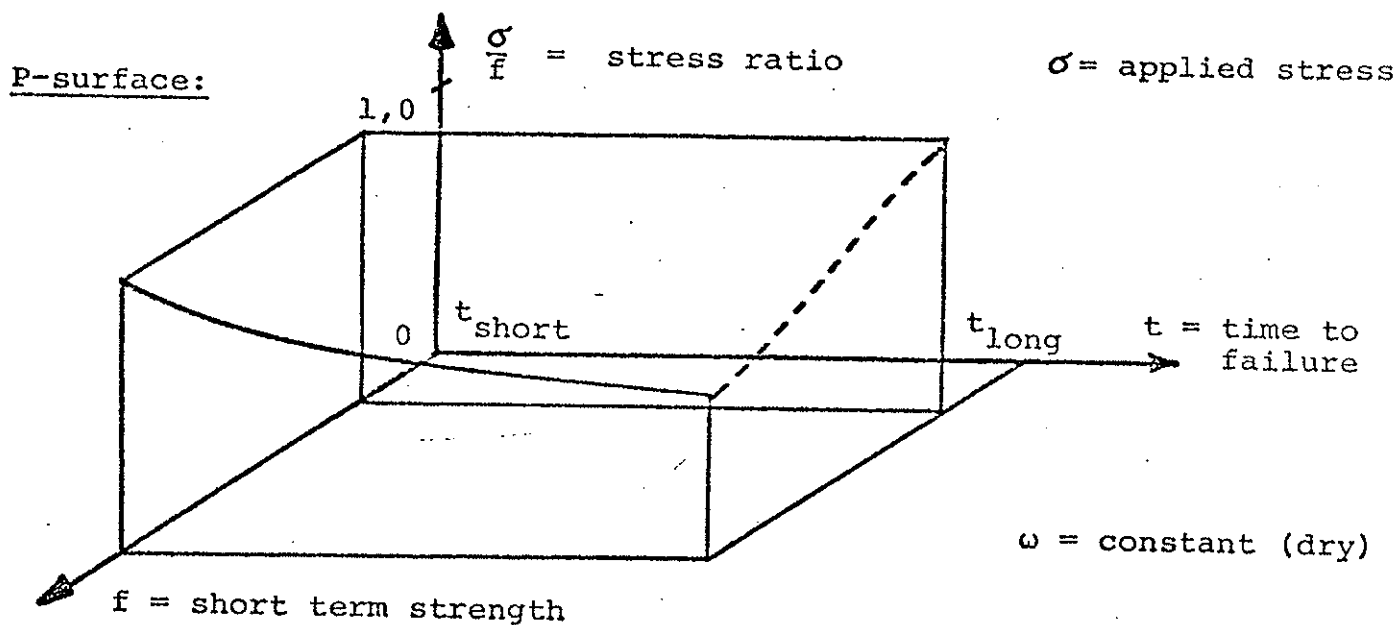

The check of the P-surface should preferably be performed on long term bending parallel to grain of European spruce and pine at different stress levels.

- b) The group recommended to start working on moisture effects by short term bending parallel to grain of European spruce and pine with different moisture contents, preferably $\omega = 0,15$ and $\omega = 0,25$.

Based on the results from these projects, research programmes are to be discussed for a number of investigations, such as:

Long term loading:

Timber in bending at variable climatic conditions.
Timber in tension parallel to grain.
Gluelam in bending parallel to grain.
Gluelam in tension perpendicular to grain.
Gluelam in torsional shear.
Joints, components and complete structures.

Short term loading: ($\omega = 0,15$ and $\omega = 0,25$)

Timber in tension parallel to grain.
Timber in compression parallel to grain.
Joints, components and complete structures.

The group is aware of the fact that some of these projects are already dealt with or planned at different research centres. The group would like to encourage this work to be continued, but also to be informed in detail about the project programmes. It is important that the projects are coordinated as far as test methods, sampling, recorded data etc. are concerned.

The following projects were reported:

HOLLAND

At the Stevin Laboratory, long term tests on mechanical joints have been carried out. A report is being prepared.

NORWAY

At Norsk Treteknisk Institutt, a project on moisture effects on short term bending has been planned, and the sampling of 48x148 mm spruce has just started. A detailed project programme will be circulated to the group before start of the actual tests.

At the Norwegian Institute of Technology, Trondheim, a pilot project on long term bending of 36x73 mm spruce has been carried out, and a report is being prepared for circulation to the group.

5. Sampling

Ideally, the tests should be carried out without linking the timber to particular grades in order to obtain results which could be converted to any visual or machine grade.

The construction of the P-surface requires the stress ratio $\frac{\sigma}{f}$ to be known. Thus, the dry short term strength, f , of the specimens for long term loading and wet loading must be known or predicted for each single test specimen.

If the strength forecasting through specimen matching cannot be achieved, a very extensive test programme based on some distributional approach will have to be carried out. The group decided that, as considerable savings would be gained by using a matched specimen approach, a solution of the matching technique should primarily be searched for.

At present, two projects investigating matching techniques are carried out by Norén and Curry respectively. The results will be reported to the group during the summer of 1977 for discussion when the group is to meet in August, 1977.

6. Test methods

The large amount of variable parameters demands that all test methods are mutually consistent. The description of specimens, test methods and recording of test data must be standardized. The group decided that all tests should be according to the RILEM-document "Standard Methods of Tests for Determining some Physical and Mechanical Properties of Timber in Structural Sizes" (to be presented at the CIB W18 meeting in Stockholm, February, 1977).

The group agreed upon the following additional conditions:

Recommended cross-section: planed 35x120 mm, alternatively approx. 50x150 mm, dimensioned or planed.

Recommended climate for long term testing: Temperature 18°-25°C, relative humidity 65 ± 3%.

7. Human and technical resources

The large research programme will, even when split into limited test projects, require considerable laboratory space and time. It is therefore necessary to get also other laboratories than those represented in the group interested in carrying out parts of the programme. It might be desirable, if possible, to use Borg Madsen's testing equipment at the University of British Columbia as far as long term testing is concerned.

Saarelainen informed that the Timber Laboratory in Finland could participate in bending tests under cycling humidity between 35 and 85% RH.

Hoffmeyer informed that the Technical University of Denmark could participate in tests on moisture effects on structural timber and to work on theoretical studies on fracture mechanics related to time and moisture effects.

Möhler informed (by letter) that the Universität Karlsruhe could participate on long term loading tests on straight and curved gluelam components, thus investigating bending parallel to grain as well as tension perpendicular to grain.

Van Amstel informed that the Stevin Laboratory could participate in long term loading of mechanical and glued joints.

The group emphasizes that all project plans and test programmes should be circulated to the group for comments and coordination at an early stage.

8. Cooperation with North America

The group decided to link its work, if possible, to the North American "Duration of Load" Steering Committee and to write to Dave Barrett for information about their present and planned activities.

9. Financing

As a basic principle, national financing should be obtained for the part of the project which will be dealt with within the country.

If the projects will be involving collaboration between Western Europe and North America, the possibility of obtaining financing through Research Grants from NATO Science Committee should be investigated.

10. Next meeting

25th - 26th August, 1977 at P.R.L., England.

Oslo, 6th December, 1976

Odd Brynildsen
