

**INTERNATIONAL COUNCIL FOR RESEARCH AND INNOVATION  
IN BUILDING AND CONSTRUCTION**

**WORKING COMMISSION W18 - TIMBER STRUCTURES**

# **CIB - W18**

**MEETING SIX**

**AALBORG**

**DENMARK**

**JUNE 1976**

CONTENTS

Inhaltsverzeichnis  
S. 14

	Page
1 LIST OF DELEGATES	ii
2 CHAIRMAN'S INTRODUCTION	1
3 KIEV SYMPOSIUM	1
4 TESTING METHODS FOR JOINTS	2
5 TESTING TIMBER IN STRUCTURAL SIZES	2
6 TESTING PLYWOOD	3
7 CLIMATIC CONDITIONS	6
8 GLULAM STRUCTURES	7
9 MECHANICAL CONNECTORS FOR TIMBER	7
10 TIMBER COLUMNS	9
11 LONG-TERM LOADING	10
12 TIMBER CODE	10
13 LIMIT STATE DESIGN	12
14 NEXT MEETING	13
15 PAPERS PRESENTED AT THE MEETING	14
16 CURRENT LIST OF CIB-W13 TECHNICAL PAPERS	16

Lehrstuhl für  
Ingenieurholzbau u. Baukonstruktionen  
Universität (TH) Karlsruhe  
Prof. Dr.-Ing. K. Möhler

E 102/76

Standort-Nr.: LH-T216  
Mw.-Nr.: E10216

Lehrstuhl für Ingegnieurholzbau  
und Baukonstruktionen  
Universität Karlsruhe  
Univ.-Prof. Dr.-Ing. H. J. Bläß

## 1 LIST OF DELEGATES

### BELGIUM

A Visser Automated Building Components, Brussels

### CANADA

R Foschi Western Forest Products Laboratory, Vancouver  
B Madsen University of British Columbia, Vancouver  
C Wilson Council of Forest Industries, North Vancouver

### DENMARK

T Feldborg Statens Byggeforskningsinstitut, Horsholm  
P Hoffmeyer Technical University of Denmark, Lyngby  
M Johansen Statens Byggeforskningsinstitut, Horsholm  
H J Larsen Institutet for Bygningsteknik, Aalborg

### FINLAND

U Saarelainen Technical Research Centre of Finland, Helsinki

### FRANCE

P E H Crubilé Centre Technique du Bois, Paris

### FEDERAL REPUBLIC OF GERMANY

P Frech Otto-Graf-Institut, Stuttgart  
K Möhler Universität Karlsruhe, Karlsruhe

### NETHERLANDS

J Kuipers Stevin Laboratory, Delft  
H Ploos van Amstel Stevin Laboratory, Delft

### NORWAY

P Aune Institutt For Stålkonstruksjoner, Trondheim  
O Brynildsen Norsk Treteknisk Institutt, Oslo  
O B Kristiansen Norges Byggstandardiseringstad, Oslo

### SOUTH AFRICA

P A V Bryant Council for Industrial and Scientific Research, Pretoria

### SWEDEN

B Norén Svensak Truforskningsinstitutet, Stockholm

### UNITED KINGDOM

H J Burgess Timber Research and Development Association, High Wycombe  
W T Curry Building Research Establishment, Princes Risborough  
L G Booth Imperial College, London  
R Marsh Arup Associates, London  
1) J G Sunley Timber Research and Development Association, High Wycombe  
2) J R Tory Building Research Establishment, Princes Risborough  
T Williams Hydro-Air International, High Wycombe

### UNITED STATES OF AMERICA

R Pellerin Washington State University, Pullman  
E G Stern Virginia Polytechnic Institute and State University,  
Blacksburg

- 1) Chairman for the meeting; Co-ordinator, CIB-W18
- 2) Technical Secretary, CIB-W18

## 2 CHAIRMAN'S INTRODUCTION

MR SUNLEY welcomed delegates to the sixth meeting of the group since it was re-formed in March 1973. He also extended a warm welcome to those members of the International Union of Forest Research Organisations (IUFRO) Wood Engineering Group who were not normally present at W18 meetings and invited them to take an active part in the proceedings and in the discussion of the papers. The Chairman briefly explained the differences between W18 and IUFRO. W18 he said was primarily concerned with producing an international timber code and this was necessarily tied to eliminating differences between national design codes and standards. IUFRO Wood Engineering Group on the other hand provided a forum for discussion on all aspects of research on the structural utilisation of timber and wood-based products, the emphasis being on research. The strong links between the two organisations, continued the Chairman, was indicated by the number of delegates who held membership in both organisations. For W18, working links had also been established with International Standards Organisation (ISO), Reunion Internationale des Laboratoires d'Essais et de Recherches sur les Materioux et les Constructions (RILEM), Joint Committee on Structural Safety (JCSS), European Economic Community (EEC) and Economic Commission for Europe (ECE); and several of the delegates present served on committees for these other organisations.

MR SUNLEY then outlined a possible programme for future meetings of W18. The next meeting he suggested should be during February or March 1977 in Stockholm and this might be followed by a meeting somewhere in Eastern Europe in October 1977. A further meeting might be held during April 1978 which he hoped would tie-in with an international engineering conference probably to be held at Imperial College, London. The next IUFRO Wood Engineering Group meeting would be in Vancouver in September 1978 and this could possibly be a joint W18-IUFRO venture similar to the present meeting. These were tentative dates he emphasised, it might even be desirable to hold more frequent meetings than he had outlined to expedite progress on the timber code.

## 3 KIEV SYMPOSIUM

MR SUNLEY reported that he, PROF LARSEN and DR KUIPERS had attended the CIB-W18 symposium earlier in June at KIEV, USSR. Of the 328 delegates 287 had been from the Soviets and 52 papers had been presented. Although the symposium had been marred by poor translation facilities it had been evident that much useful work was being done in Russia and they had ambitious plans for expansion in some fields. He gave as an example a proposed five-year plan to expand glulam production from 6000 to 36000 m<sup>3</sup>/ year. Several institutes were working on glulam and plywood and work was also proceeding on timber codes. The Russians had been asked to co-operate more actively with W18 and had been invited to attend the next meeting in Stockholm when for their benefit glulam would feature as a major part of the proceedings.

DR KUIPERS agreed that communication at the Symposium had been difficult but he had been most impressed by the scope of the practical and theoretical work; in particular on panels, glulam fatigue, reinforced glulam and non-corrosive glass-fibre jointing plates.

PROF LARSEN commented that the Russian design procedures were old-fashioned and he suggested that they could learn from us in that field. PROF LARSEN had also been disappointed that Western European organisations had not exploited commercial possibilities in the enormously large expanding Russian market where there was great potential for our relatively sophisticated timber technology.

MR SUNLEY concluded the report on the Kiev symposium by pointing out that Russia too had wood engineering problems. He had been told of large glulam beams that had failed at 41 per cent of their characteristic bending strength and at very low radial stresses.

#### 4 TESTING METHODS FOR JOINTS

DR KUIPERS introduced the seventh draft of a paper "Recommendations for Testing Methods for Joints with Mechanical Fasteners and Connectors in Load-bearing Timber Structures" (CIB-W18/6-7-1). He pointed out that there were few changes from the previous draft presented at Karlsruhe and proposed publication now as a joint W18/RILEM document.

PROF LARSEN suggested some minor editorial changes to the text (section 6.1.4) and that the paper should be edited into the standard form for presentation to ISO.

PROF MADSEN asked for clarification of the samples that were to be associated with the testing methods detailed in the paper. There was no guidance in the paper, he said, on whether the tests should be conducted on clear timber or on timber containing defects.

In answer to this question MR CURRY agreed with PROF LARSEN that sampling, testing and the interpretation of data were separate issues, each requiring individual documentation.

DR NOREN pointed out that section 7 of the paper made full provision for any sampling procedure provided it was adequately described.

MR VISSER suggested that section 7 should also require reference to the method of fabrication of the joints.

It was finally agreed that DR KUIPERS and MR SUNLEY would write an introduction for the paper and that after scrutiny by the secretary and MR CURRY it should be published and submitted to ISO.

#### 5 TESTING TIMBER IN STRUCTURAL SIZES

The third draft of his paper "Standard Methods of Test for the Determination of Some Physical and Mechanical Properties of Timber in Structural Sizes" (CIB-W18/6-6-1) was introduced by MR CURRY who also suggested that this paper was now ready for publication.

PROF LARSEN said that some of the symbols used in the text were not consistent with what had been agreed at previous meetings. In particular he wished to see ' $\sigma$ ' for stress and ' $f$ ' reserved for strength which could be defined as the ultimate stress.

MR CURRY agreed to check the symbols for agreement with the earlier proceedings.

PROF MADSEN was concerned at the implication that this proposed standard would exclude other methods of testing structural timber. He pointed out that these test methods were relatively slow compared with his own methods which allowed the testing of five or six hundred specimens each day. He was not convinced that rate of loading was a significant factor in testing. A further point raised by

PROF MADSEN was the positioning of the 'worst' defect in the tension zone in the bending specimen. By doing this he argued it was no longer possible to determine a fifth percentile for a species of structural timber.

DR NOREN said that this standard would not necessarily exclude other methods. The decision as to which method to adopt would be largely political but it was desirable to have this document to assist with the free interchange and combination of compatible test data. One was not obliged to abide by this standard any more than by any other he added, but there were advantages in standardisation.

MR CURRY pointed out that test methods were, in this case as with the previous paper on joints (6-7-1), remote from sampling and the derivation of characteristic stresses. He continued, in answer to a question from PROF LARSEN, to agree that moisture content or exposure conditions should be defined by another standard on climatic conditions rather than appear in this paper.

PROF LARSEN then turned to Figure 1 and the recording of knot data. The fault with this system he contended was that it was not possible to go back from the data to the original knot shape and this precluded the extraction of information on surface dimensions and for margins of other than fractions of sixteenths of the section depth.

MR SAARELAINEN referred to the practice in Finland of recording knots by a co-ordinate system which eliminated these disadvantages.

The meeting agreed that although the existing wording did not exclude other methods it was desirable to include a co-ordinate system and the Chairman asked MR SAARELAINEN to make his method available for inclusion in this standard.

PROF LARSEN requested that other than metal plates should be permitted in section 7.1.1 and this was agreed.

PROF HOFFMEYER objected to the use of spherically seated loading heads, specified in section 7.3.1. If these were used he pointed out, one would be unable to achieve uniform strain and non-uniform strain implied bending stresses. Perhaps both spherical and rigid seatings should be permitted for loading heads he suggested.

MR SUNLEY asked PROF HOFFMEYER to draft a suitable paragraph to cover loading heads for compression testing.

MR CURRY agreed with DR KUIPERS and PROF LARSEN that references to the 'critical section' should be deleted since the section to be tested depended on the results that were required.

PROF MOHLER had intended to present a paper to the meeting on test methods for shear modulus but he explained that tests were still proceeding and results were not yet available for inclusion in a standard on test procedures.

MR SUNLEY suggested that the present paper on test methods should be published and presented to ISO and if as a result of his work PROF MOHLER wished to introduce amendments then this could be done at ISO.

## 6 TESTING PLYWOOD

DR BOOTH, in introducing his paper "The Determination of the Mechanical Properties of Plywood Containing Defects" (CIB-W18/6-4-1) said that he had tried to incorporate

views expressed at earlier proceedings and especially those of DR KUIPERS and DR WILSON. The paper had originally been written as a British Standard he continued, but he was now seeking wider acceptance of its contents including several points of principle. DR BOOTH listed these points as:

- i Should bending strength, tension strength and other properties all be incorporated in one standard?
- ii Should the standard be expanded to include detailed explanations similar to the ASTM standards?
- iii Two methods of carrying out bending tests are given in the paper. Should both be included?
- iv Should there also be two methods of test for panel shear?
- v If alternative methods of test are included in the standard should one be labelled as 'preferred'?
- vi If alternative methods of test are included should it be longer term policy to delete one of them?
- vii Should sampling procedures be detailed in this standard or in a separate document?
- viii This paper stipulates that the maximum size of defect for the grade should be included in the test specimen. Is this acceptable or should there be random sampling?
- ix How should one determine characteristic stresses? And should this topic be covered by another document?
- x The paper suggests a compromise for specimen size between that adopted by COFI and that of the ASTM. Is this compromise satisfactory?
- xi From the limited data available strength would appear to be related to specimen size. If this is a genuine observation should one not establish size modification factors?

MR SUNLEY opened the discussion on this paper by asking for opinions on whether there should be one document or two. On the first point he said, there was almost certainly agreement that the testing of all properties should be included in the one standard.

DR BOOTH expressed the opinion that there should be one short document although DR WILSON thought that two might be required if explanations were to be included.

PROF MADSEN said that a satisfactory solution might be a separate commentary on the standard, similar in style to the commentary on CP 112 by Booth and Reece but DR BOOTH was not in favour of this idea.

A protracted discussion took place on the bending tests for plywood. PROF LARSEN was of the opinion that both methods of testing bending strength would produce similar results. He said that one method was sufficient and it should not be confined to a patented machine. Why could not pure bending be specified over a given gauge length for a 300 mm test specimen and let everyone use their own methods he asked?

DR BOOTH agreed that the best standards confined themselves to one method and he favoured this. The ASTM method gave a constant bending moment over a longer span than the other method. Finland however would probably prefer third-point loading on smaller specimens and not all laboratories had the facilities for testing the four foot wide material preferred by COFI. DR BOOTH also explained that there was no test evidence comparing the different methods.

DR WILSON said that more test work was required to investigate the effects of specimen size on strength properties.

DR BOOTH thought that modification factors would almost certainly be required to compensate for width effects whatever size of specimen was used but the main problem was not one of specimen size but of how to test them satisfactorily when deflections were so large.

PROF LARSEN saw no reason to specify a particular test machine since this was not done for any other test. He repeated his earlier view that the definition of pure bending over a set gauge length and span should be sufficient.

DR BOOTH then asked the meeting for opinions on which panel shear test should be adopted.

DR WILSON spoke in favour of the two-rail test since that was the method used by COFI.

DR BOOTH pointed out that the two-rail method could not give an accurate value for modulus of rigidity and therefore an additional test, probably torsional, would be required to determine this property.

In spite of this disadvantage no delegate spoke or indicated support for the four-rail test method.

DR BOOTH next asked the meeting if another document was necessary to specify sampling methods and what form of sampling should be recommended.

The statistical problems, said DR NOREN, were the same as those for solid timber and the sample to be tested would depend on whether "true" fifth percentiles were required or minimum values based on weaker pieces.

PROF LARSEN asked how 'weaker' pieces were to be selected. The problem with many concealed laminations was even greater than with solid timber he said.

DR BOOTH agreed that this was a problem but thought that for the present fifth percentiles should be conservatively based on apparently weak pieces until more information was available on sampling effects.

DR NOREN volunteered to try to investigate sampling techniques and effects but he was not prepared to commit himself to a lengthy investigation.

PROF MADSEN said that random sampling would produce direct results without complication but if maximum grade defects were selected then further study would be required to investigate their frequency so that realistic fifth percentiles could be estimated.

MR SUNLEY urged the meeting to make positive decisions. In six months time he said laboratories would be testing plywood, hopefully to a W18 based standard. What is the best advice we can give them now, he asked.

The general feeling among the delegates was that a 300 mm wide bending specimen should be used and that the selection of specimens should be by random sampling.

The next subject for consideration from this paper was rolling shear. DR BOOTH said that Madison laboratory had found defect size, within very wide limits, had no effect on this property and therefore the specimen size need not be as large as 150 x 450 mm. However, continued DR BOOTH, rolling shear was probably the most size-dependant of all the strength properties and it was most desirable to have comparative tests for different sizes. Only genuine rolling shear failures should be included in data used to establish lower percentile stresses he said, although the practice in COFI was to include all test results regardless of the form of failure.

The Chairman proposed that a small sub-committee consisting of DR BOOTH, DR WILSON, DR NOREN and DR KUIPERS should consider the content of the paper and what amendments were required. In addition the Chairman suggested that DR NOREN should consider how characteristic stresses for plywood should be derived.

DR BOOTH reported later that a revised draft of his paper would be provided within one month for circulation by the secretary.

DR WILSON introduced "Comparison of the Size and Type of Specimen and Type of Test on Plywood Bending Strength and Stiffness" (CIB-W18/6-4-2), describing the test objectives and drawing attention to "surprisingly low coefficients of variation for the in-grade specimens".

In answer to a question from MR SUNLEY, DR WILSON said that the 1.58 ratio of small clear in-grade mean modulus of rupture had been lower than expected.

DR BOOTH asked if Finland might carry out a similar series of tests although perhaps they would not expect the ratio of small clear in-grade strength to be as high as 1.58.

MR SAARELAINEN answered that test results would soon be available from the FPDA and these showed little difference between fifth percentile values for small and large specimens. Copies of a draft report including these results had been sent to MR CURRY and DR BOOTH he added.

DR KUIPERS presented the paper "Buckling Strength of Plywood: Results of Tests and Recommendations for Calculations" (CIB-W18/6-4-3) pointing out that the purpose of this paper was simply to inform delegates of the work being done in Holland.

PROF LARSEN commented that the conclusions on end-fixity were most interesting as were the methods of providing simply-supported conditions for the edges of the boards.

In answer to a question from DR BOOTH, DR KUIPERS admitted that although defects had been present in the boards they had not been taken into account in the calculations but he thought it unlikely that they would have had a dominating effect. From the experiment he said, they had concluded that reasonable agreement existed between the real and theoretical behaviour of buckling plywood except for clamped boundary conditions which they had been unable to achieve.

## 7 CLIMATIC CONDITIONS

DR NOREN introduced his paper "Climate Grading" (CIB-W18/6-11-1) suggesting that now that he had incorporated the changes recommended at Karlsruhe the paper was ready for inclusion in the CIB Code.

Both PROF LARSEN and MR SUNLEY questioned the use of 23°C as the standard temperature although they agreed that if this was the ISO standard then it should remain unaltered even though conversion factors might be required for some test results.

It was agreed that this paper should be written into the Code.

## 8 GLULAM STRUCTURES

DR KUIPERS introduced the paper "Directives for the Fabrication of Load-bearing Structures of Glued Timber" (CIB-W18/6-12-1) which he said was an initial draft for a Dutch standard on glulam structures and illustrated the probable layout and contents. He pointed out that the climatic conditions were not the same as those that had just been discussed in paper 6-11-1.

MR FRECH commented that phenolic-formaldehyde glue would not be acceptable in glulam structures in Germany.

PROF LARSEN accepted that this paper introduced glulam to W18 for the first time but he thought it too detailed to form part of a timber code. He agreed with MR SUNLEY that W18 should produce a standard for glulam and that this would present no insurmountable problems. PROF LARSEN continued, suggesting that in a W18 document the selection on materials should follow the pattern already established for solid timber where W18 was responsible for stresses alone and not for grading limits. He also favoured the evaluation of results following the solid timber pattern but he foresaw difficulties in sampling.

## 9 MECHANICAL CONNECTORS FOR TIMBER

PROF MOHLER apologised for a misunderstanding over the translation of his paper "Testing of Integral Nail-plates as Timber Joints" (CIB-W18/6-7-2). An English translation of the paper was not available for the meeting but PROF MOHLER undertook to have the paper translated and to circulate it through the secretary to all members. (Circulation has been achieved by including the translated paper in these proceedings).

DR NOREN introduced his paper "Comments to Rules for Testing Timber Joints and Derivation of Characteristics Values for Rigidity and Strength" (CIB-W18/6-7-4).

MR CURRY stated that he was not very satisfied with the methods given in Appendix 1 for selecting the wood for the joints.

DR KUIPERS asked why there should be only two methods of selecting the wood and both based on density. Why not permit random selection or base the selection on quality he asked.

PROF LARSEN pointed out that by selecting the timber for the joint on the basis of density one parameter influencing the strength of the joint was being eliminated. Random or grade selection of the wood would permit the inclusion of this parameter whose contribution to the variability of the results was unknown he said.

DR NOREN explained that other methods of selecting wood for joint tests were in use. IN the UK for example it was acceptable if the wood was within a single wide range of density. In Germany wood was selected on the basis of compression strength although this method he said was more difficult and more expensive to operate.

MR BRYANT told the meeting of the South African practice of testing joints within three wood density bands in order to cover their very wide species and density ranges. Joint slip and load characteristics had been found to vary with density he said.

MR CURRY pointed out that the paper was concerned only with European pine and spruce. He proposed that to cater for other species, including hardwoods, high and low density levels should be related to the density spectrum for the species. It would be necessary to cover both ends of the density spectrum he contended, to allow for those fasteners whose mode of failure might be different at the extremes of density.

PROF LARSEN favoured one characteristic density for each of four species groups arranged perhaps in a geometric progression. This he believed would eliminate the problem of considering different types of failure.

MR BRYANT supported DR NOREN in preferring density rather than compression strength as the basis for the wood selection. He said that South African tests had shown high correlations between density and joint strength for individual and mixed species.

DR BOOTH reminded delegates that although this paper was primarily concerned with joints in solid timber they should bear in mind that there would soon be a need to test similar fasteners in plywood where variations in density occurred between plies.

MR SUNLEY agreed that this was a definite possibility but that at this stage discussion should be confined to solid timber and if possible to European spruce and pine.

DR KUIPERS was rather sceptical about MR BRYANT's earlier statements. He would like to see evidence of these high correlations he said.

Evidence from another source was quickly produced in the form of a report passed around the table by PROF STERN. This report (Performance of Pallet Nails and Staples in 22 Hardwoods, E George Stern, Virginia Polytechnic Institute and State University, June 1976), said PROF STERN, showed scatter diagrams of specific gravity versus joint strength for twenty two mixed hardwood species. High correlations were achieved for individual and mixed species he said.

MR SUNLEY, summing up the views from several delegates, said that there did not appear to be very much to choose between selecting timber for joint tests on the basis of density or on the basis of compression strength. Prof Mohler he said, favoured compression strength because the Germans believed pin bearing to be a major factor in determining joint strength whereas most other people accepted density primarily because it was easier. MR SUNLEY continued, saying that he felt the correct solution might be to test joints in low density timber.

MR FOSCHI said that to satisfactorily define characteristic strengths for joints the mode of failure should be consistent for all test results and this would depend on nail spacing, tooth profile, nailing patterns and other factors as well as density of wood.

MR SUNLEY said that the testing specification that was now proposed might be difficult to adopt in the UK since tests were often carried out that were confined to specific timber species and sources of supply.

PROF LARSEN pointed out that it would not be practicable to treat every individual case in the timber code.

Introducing "Rules for Evaluation of Values of Strength and Deformation from Test Results - Mechanical Timber Joints" (CIB-W18/6-7-3). DR NOREN said that parts of this paper were based on the Nordic Code. He also said that correction factors might be applied to either the results of individual tests or to calculated characteristic values whichever was better.

MR CURRY did not agree with this last comment. He considered it difficult to show that factors applied to characteristic values were worse or better than factors applied to individual results.

PROF MADSEN felt that this paper could form a reasonable foundation for a more general timber-based paper.

After a short discussion on sampling rules and their documentation it was agreed that DR NOREN should expand paper 6-7-4 into a more general document and that paper 6-7-3 should be included in the Code although some amendments might have to be made to it in the future.

## 10 TIMBER COLUMNS

PROF LARSEN introduced the paper "Comments on Document CIB-W18/5-100-1, Design of Timber Columns" (CIB-W18/6-100-1). He briefly explained timber column design and how the original Perry formula had not been appropriate for timber since the theory of superposition and the addition of stresses could not be used as they had been for steel. He continued by explaining that the grading limits for bow were greatly in excess of reasonable theoretical eccentricities.

DR KUIPERS said that in Holland they had special grading rules for columns.

MR BRYNILDSEN commented that if it were necessary to have special rules for columns then they should also apply to the internal compression members in trusses.

PROF LARSEN suggested that the eccentricity values in the Timber Standard should hold until they could be improved. He added that having inspected many trusses and other structures he had not encountered bow approaching the limits for the grades.

PROF LARSEN presented his paper "Lattice Columns" (CIB-W18/6-2-1) saying that it was self-explanatory and required no discussion. This view was accepted.

MR BURGESS introduced "A Mathematical Basis for Design Aids for Timber Columns" (CIB-W18/6-2-2) which he said set out a mathematical basis for design charts.

MR SUNLEY pointed out that design aids were useful but many people still preferred calculations for individual members.

MR BURGESS then introduced "Comparison of Larsen and Perry Formulas for Solid Timber Columns" (CIB-W18/6-2-3). He drew attention to the similarity between equation (7) that is currently in use in the UK and equation (5).

PROF LARSEN objected to the use of the term "Larsen formula". As Mr Burgess had shown, he said, this formula was simply a manipulated modified Perry formula. PROF LARSEN disclaimed any contribution to the formula.

DR BOOTH said that one serious omission from all the papers on column design was that none of them considered lateral deflection.

After a short discussion it was decided that PROF LARSEN should try to derive suitable expressions for the lateral deflection of timber columns.

## 11 LONG-TERM LOADING

MR JOHANSEN stated that the paper "Deflection of Trussed Rafters Under Alternating Loading During a Year" (CIB-W18/6-9-3) was a progress report on a continuing test programme and discussion would be more appropriate when the final report had been written.

DR NOREN introduced his paper "Long-term loading for the Code of Practice (Part 2) (CIB-W18/6-9-1) explaining the loading assumptions that had been made and the method of load conversion. He pointed out that there was apparently an error in Figure 3 - the load should never reduce to zero. DR NOREN also pointed out that guidance would be required in a CIB Code on what proportions of creep or deflection were elastic or irrecoverable.

PROF LARSEN, while accepting the method of load conversion, pointed out that it could be dangerous to generalise. He gave as an example very short term wind loads that might be strong enough to cause overturning.

DR NOREN agreed that it might be necessary to link these ideas with a time-to-failure consideration and that this paper was not yet at a stage where it could be incorporated into the Code.

PROF MOHLER introduced "Long-term Loading" (CIB-W18/6-9-2) saying that this paper was the result of tests on clear specimens.

MR SUNLEY suggested that this paper was more research than application of research and might be more suitable for a IUFRO meeting.

PROF MADSEN said that he had shown that in bending the effect of long-term loading was a function of strength.

There was no further discussion on the paper.

## 12 TIMBER CODE

MR SUNLEY opened the discussion on PROF LARSEN's "CIB Timber Code: CIB Timber Standards" (CIB-W18/6-100-2) by explaining that this initial draft would eventually form Volume 6 of the CIB Design Code and should harmonise with Volume 1.

MR SUNLEY suggested that the paper be studied page by page and the following comments were made.

title page	MR MARSH asked if the title was correct. Several suggestions were made with most support for "Timber Structural Design Code".
contents	MR SUNLEY said that there appeared to be no logical distinction between the topics for the Code and for the standards. Beam design was in the Code and column design in a standard.

MR BRYANT pointed out that bracing was not included in the Code.

PROF LARSEN agreed that bracing should be included. He thought it would best fit in under section 7 and that section 8 should refer back to section 7.

- Section 2.1 DR KUIPERS asked why only fifth percentile characteristic stresses were mentioned. He considered that more statistical information should be provided so that individual countries could derive their own permissible stresses.
- PROF LARSEN explained that safety and other factors had deliberately been omitted. It might be necessary to amend this page depending on the content of other volumes of the Design Code but he expected that only the fifth percentile would be given.
- Section 2.2 DR NOREN pointed out that his paper (CIB-W18/6-11-1) had now been adopted for this section.
- Section 2.3.1 PROF LARSEN said that factors for the four classes of duration of load had yet to be decided.
- DR BOOTH suggested that shuttering and formwork should have a different classification to wind.
- Section 3.0 In answer to a question from DR KUIPERS, PROF LARSEN explained that it was necessary to include approximate dimensional changes due to changes in moisture content because dimensional changes could induce loads.
- Section 3.1.1 PROF LARSEN said the last paragraph could be deleted since it was repeated in section 5.1.
- Section 3.1.2 PROF LARSEN explained that the coefficient  $\alpha$  was based on the assumption of a normal distribution because of the lack of alternative evidence.
- Section 3.2.1 DR BOOTH asked if Volume 1 treated buckling as a limit state.
- PROF LARSEN said that it did but that different factors of safety might be associated with different limit states.
- Section 3.4 MR SUNLEY thought that deflection limits should appear in this section.
- Section 4.1 PROF LARSEN suggested that it was not the function of W18 to write this section but the responsibility of the manufacturers.
- Section 5.1.1 It was agreed that "engineers bending theory" should replace "the ordinary technical theory of elasticity".
- Section 5.1.3 DR BOOTH expressed doubts about using the theory of elasticity and previous papers on the design of timber beams for all species regardless of their f:E ratio.

Section 5.1.1.7 PROF LARSEN agreed that the eccentricities might be changed and a method of calculating lateral deflections should be introduced.

Section 6.1 MR BURGESS asked why there should be restraint to prevent buckling. He pointed out that this was not an unstable elastic stage and therefore not an ultimate limit state. It was, he suggested, a serviceability limit state.

After some discussion it was agreed that theoretically Mr Burgess was correct but that nevertheless buckling should be avoided and the Code should advise on how this could be done.

Section 6.2 DR KUIPERS asked why only two types of fastener were mentioned.

PROF LARSEN agreed that screws and beveled split-ring connectors should be included. He also pointed out that E values had yet to be given.

In summing up the discussion on this paper MR SUNLEY said that naturally there was still a great deal of work to be done on this Code. He continued that perhaps mention should be made of preservative treatments and more references to other standards might be required. However, the final format and content of the Code could not be decided he said, until Volume 1 had been seen and commented on by all the members of W18 and he expected that this could be done before the next meeting.

### 13 LIMIT STATE DESIGN

The last morning of the two-and-a-half day W18 meeting was devoted to a talk by MR SKOV who explained the content of his paper "On the Application of the Uncertainty Theoretical Methods for the Definition of the Fundamental Concepts of Structural Safety" (CIB-W18/6-1-1).

PROF MADSEN and DR BOOTH were both curious as to the effect of varying the distributional assumptions. Would this they asked, upset the calculation of the beta factors.

MR SKOV agreed that it would. The method he was advocating depended to a large extent on approximating the actual distributions of strengths and loadings by normal distributions.

DR KUIPERS asked what was to be gained from the probabalistic methods of design.

MR SUNLEY answered that the only probable gain would be the increased confidence we could have in structures although there might be some minor material benefits too.

PROF MADSEN suggested that since a probabalistic design method would necessarily be calibrated against existing structures the implication was therefore that the present conservatism would be retained.

After several other questions MR SKOV concluded by reiterating his opinion that now was the time to start thinking of and introducing probabalistic design.

MR SUNLEY wound up the discussion and the meeting by thanking Mr Skov for an interesting and informative talk. On behalf of all the delegates he also thanked Professor Larsen as host for his hospitality and for the facilities that had been made available for the meeting.

#### 14 NEXT MEETING

The next meeting of CIB-W18 will be during the week beginning 28 February 1977 in Stockholm, Sweden. At that meeting the main topics for discussion will be:

- 1 Plywood - DR BOOTH to provide a second draft of paper 6-4-1.
- 2 Sampling and Derivation of Characteristic Stress - DR NOREN to extend the scope of paper 6-7-4 to include plywood and solid timber.
- 3 Timber Columns - PROF LARSEN to make proposals for methods of calculating lateral deflection.
- 4 Glulam - Grading, sampling and testing of glulam structures.
- 5 RILEM - DR KUIPERS, DR BOOTH, MR BRYANT, MR CURRY to report on the activities of RILEM.
- 6 Unified System of Structural Codes - Volume 1 of JCSS Code for discussion.
- 7 Timber Code - amended version for discussion.

15 PAPERS PRESENTED AT THE MEETING

- ✓ CIB-W18/6-1-1 On the Application of the Uncertainty Theoretical Methods for the Definition of the Fundamental Concepts of Structural Safety - K Skov and O Ditlevsen.
- ✓ CIB-W18/6-2-1 Lattice Columns - H J Larsen.
- ✓ CIB-W18/6-2-2 A Mathematical Basis for Design Aids for Timber Columns - H J Burgess.
- ✓ CIB-W18/6-2-3 Comparison of Larsen and Perry Formulas for Solid Timber Columns - H J Burgess.
- ✓ CIB-W18/6-4-1 The Determination of the Mechanical Properties of Plywood Containing Defects - L G Booth.
- ✓ CIB-W18/6-4-2 Comparison of the Size and Type of Specimen and Type of Test on Plywood Bending Strength and Stiffness - C R Wilson.
- ✓ CIB-W18/6-4-3 Buckling Strength of Plywood: Results of Tests and Recommendations for Calculations - J Kuipers and H Ploos van Amstel.
- ✓ CIB-W18/6-6-1 Standard Methods of Test for the Determination of Some Physical and Mechanical Properties of Timber in Structural Sizes (Third Draft) - W T Curry.
- ✓ CIB-W18/6-7-1 Recommendations for Testing Methods for Joints with Mechanical Fasteners and Connectors in Load-bearing Timber Structures (Seventh Draft) - RILEM 3TT Committee.
- ① CIB-W18/6-7-2 Testing of Integral Nail-plates as Timber Joints - K Mühler.
- ✓ CIB-W18/6-7-3 ○ Rules for Evaluation of Values of Strength and Deformation from Test Results - Mechanical Timber Joints - M Johansen, J Kuipers, B Noreén.
- ✓ CIB-W18/6-7-4 ○ Comments to Rules for Testing Timber Joints and Derivation of Characteristic Values for Rigidity and Strength - B Noreén.

✓ CIB-W18/6-9-1 Long-term Loading for the Code of Practice (Part 2) - B Norén.

① CIB-W18/6-9-2 Long-term Loading - K Möhler.

✓ CIB-W18/6-9-3 Deflection of Trussed Rafters Under Alternating Loading During a Year - T Feldborg and M Johansen.

✓ CIB-W18/6-11-1 Climate Grading (second draft) - B Norén.

✓ CIB-W18/6-12-1 Directives for the Fabrication of Load-bearing Structures of Glued Timber - A van der Velden, J Kuipers.

✓ CIB-W18/6-100-1 Comments on Document CIB-W18/5-100-1, Design of Solid Timber Columns - H J Larsen and E Theilgaard.

✓ CIB-W18/6-100-2 CIB Timber Code: CIB Timber Standards - H J Larsen.

## 16 CURRENT LIST OF CIB-W18 TECHNICAL PAPERS

Technical papers presented to Working Commission W18 - Timber Structures are classified by a code identifying the meeting at which the paper was presented, the subject heading and the number of the paper. The full classification number of a document will start with CIB-W18, although where the context is clear this prefix may be omitted.

Example: CIB-W18/4-102-5

refers to paper 5 (Extract from Norwegian Standard NS 340 - "Timber Structures") on subject 102 (Structural Design Codes) presented at the fourth meeting of W18 (Paris, February 1975).

Published documents emanating from the Commission will simply be numbered in the order in which they appear.

Meetings are classified in chronological order:

- 1 Princes Risborough, England; March 1973
- 2 Copenhagen, Denmark; October 1972
- 3 Delft, Netherlands; June 1974
- 4 Paris, France; February 1975
- 5 Karlsruhe, Federal Republic of Germany; October 1975
- 6 Aalborg, Denmark; June 1976

Subjects are denoted by the following numerical classification:

- 1 Limit State Design
- 2 Timber Columns
- 3 Symbols
- 4 Plywood
- 5 Stress Grading
- 6 Stresses for Solid Timber
- 7 Timber Joints and Fasteners
- 8 Load Sharing
- 9 Long-term Loading
- 10 Timber Beams
- 11 Environmental Conditions
- 12 Laminated Members
- 13 Particle and Fibre Building Boards
- 14 Trussed Rafters

- 100 CIB Timber Code
- 101 Loading Codes
- 102 Structural Design Codes
- 103 International Standards Organisation
- 104 Joint Committee on Structural Safety
- 105 CIB Programme, Policy and Meetings

Listed below, by subjects, are all papers that have to date been presented to W13. When appropriate some papers are listed under more than one subject heading.

#### LIMIT STATE DESIGN

- 1-1-1 Paper 5 Limit State Design - H J Larsen
- 1-1-2 Paper 6 The use of partial safety factors in the new Norwegian design code for timber structures - O Brynildsen
- 1-1-3 Paper 7 Swedish code revision concerning timber structures - B Noreén
- 1-1-4 Paper 8 Working stresses report to British Standards Institution Committee BLCF/17/2
- 6-1-1 On the application of the uncertainty theoretical methods for the definition of the fundamental concepts of structural safety - K Skov and O Ditlevsen

#### TIMBER COLUMNS

- 2-2-1 Paper 3 The Design of Solid Timber Columns - H J Larsen
- 3-2-1 Paper 6 Design of Built-up Timber Columns - H J Larsen
- 4-2-1 Paper 3 Tests with Centrally Loaded Timber Columns - H J Larsen and Svend Sondergaard Pedersen
- 4-2-2 Paper 4 Lateral-Torsional Buckling of Eccentrically Loaded Timber Columns - B Johansson
- 5-9-1 Strength of a Wood Column in Combined Compression and Bending with respect to Creep - B Kålsner and B Noreén
- 5-100-1 Design of Solid Timber Columns - H J Larsen
- 6-100-1 Comments on Document 5-100-1, Design of Timber Columns - H J Larsen
- 6-2-1 Lattice Columns - H J Larsen
- 6-2-2 A Mathematical Basis for Design Aids for Timber Columns - H J Burgess
- 6-2-3 Comparison of Larsen and Perry Formulas for Solid Timber Columns - H J Burgess

## SYMBOLS

- 3-3-1 Paper 5 Symbols for Structural Timber Design - J Kuipers and B Noren
- 4-3-1 Paper 2 Symbols for Timber Structure Design - J Kuipers and B Noren
- 1 Symbols for Use in Structural Timber Design

## PLYWOOD

- 2-4-1 Paper 1 The Presentation of Structural Design Data for Plywood - L G Booth
- 3-4-1 Paper 3 Standard Methods of Testing for the Determination of Mechanical Properties of Plywood - J Kuipers
- 3-4-2 Paper 4 Bending Strength and Stiffness of Multiple Species Plywood - C K A Stieda
- 4-4-4 Paper 5 Standard Methods of Testing for the Determination of Mechanical Properties of Plywood - Council of Forest Industries, BC
- 5-4-1 The Determination of Design Stresses for Plywood in the Revision of CP 112 - L G Booth
- 5-4-2 Veneer Plywood for Construction - Quality Specification - ISO/TC 139 - Plywood, Working Group 6
- 6-4-1 The Determination of the Mechanical Properties of Plywood Containing Defects - L G Booth
- 6-4-2 Comparison of the Size and Type of Specimen and Type of Test on Plywood Bending Strength and Stiffness - C R Wilson
- 6-4-3 Buckling Strength of Plywood: Results of Tests and Recommendations for Calculations - J Kuipers and H Ploos van Amstel

## STRESS GRADING

- 1-5-1 Paper 10 Quality specifications for sawn timber and precision timber - Norwegian Standard NS 3080
- 1-5-2 Paper 11 Specification for timber grades for structural use - British Standards BS 4978
- 4-5-1 Paper 10 Draft Proposal for an International Standard for Stress Grading Coniferous Sawn Softwood - ECE Timber Committee

## STRESSES FOR SOLID TIMBER

- 4-8-1 Paper 11 Derivation of Grade Stresses for Timber in UK - W T Curry
- 5-6-1 Standard Methods of Test for Determining some Physical and Mechanical Properties of Timber in Structural Sizes - W T Curry
- 5-6-2 The Description of Timber Strength Data - J R Tory
- 5-6-3 Stresses for EC1 and EC2 Stress Grades - J R Tory

- 6-6-1 Standard Methods of Test for the Determination of some Physical and Mechanical Properties of Timber in Structural Sizes (third draft) - W T Curry

#### TIMBER JOINTS AND FASTENERS

- 1-7-1 Paper 12 Mechanical fasteners and fastenings in timber structures - E G Stern
- 4-7-1 Paper 8 Proposal for a Basic Test Method for the Evaluation of Structural Timber Joints with Mechanical Fasteners and Connectors - RILEM, 3TT Committee
- 4-7-2 Paper 9 Test Methods for Wood Fasteners - K Mähler
- 5-7-1 Influence of Loading Procedure on Strength and Slip Behaviour in Testing Timber Joints - K Mähler
- 5-7-2 Recommendations for Testing Methods for Joints with Mechanical Fasteners and Connectors in Load-Bearing Timber Structures - J Kuipers
- 6-7-1 Recommendations for Testing Methods for Joints with Mechanical Fasteners and Connectors in Load-Bearing Timber Structures (seventh draft) - RILEM 3TT Committee
- 6-7-2 Testing of Integral Nail-plates as Timber Joints - K Mähler
- 6-7-3 Rules for Evaluation of Values of Strength and Deformation from Test Results - Mechanical Timber Joints - M Johansen, J Kuipers, B Norén
- 6-7-4 Comments to Rules for Testing Timber Joints and Derivation of Characteristic Values for Rigidity and Strength - B Norén

#### LOAD SHARING

- 3-8-1 Paper 8 Load Sharing - An investigation on the State of Research and Development of Design Criteria - E Levin
- 4-8-1 Paper 12 A Review of Load Sharing in Theory and Practice - E Levin
- 4-8-2 Paper 13 Load Sharing - B Norén

#### LONG-TERM LOADING

- 3-9-1 Paper 7 Definitions of Long-Term Loading for the Code of Practice - B Norén
- 4-9-1 Paper 14 Long-Term Loading of Trussed Rafters with Different Connection Systems - T Feldborg and M Johansen
- 5-9-1 Strength of a Wood Column in Combined Compression and Bending with respect to Creep - B Källsner and B Norén

- 6-9-1 Long-Term Loading for the Code of Practice (Part 2) - B Norén
- 6-9-2 Long-Term Loading - K Möhler
- 6-9-3 Deflection of Trussed Rafters under Alternating Loading during a Year - T Feldborg and M Johansen

#### TIMBER BEAMS

- 4-10-1 Paper 6 The Design of Simple Beams - H J Burgess
- 4-10-2 Paper 7 Calculation of Timber Beams Subjected to Bending and Normal Force - H J Larsen
- 5-10-1 The Design of Timber Beams - H J Larsen

#### ENVIRONMENTAL CONDITIONS

- 5-11-1 Climate Grading for the Code of Practice - B Norén
- 6-11-1 Climate Grading (second draft) - B Norén

#### LAMINATED MEMBERS

- 6-12-1 Directives for the Fabrication of Load-bearing Structures of Glued Timber - A Van der Velden and J Kuipers

#### TRUSSED RAFTERS

- 4-9-1 Paper 14 Long-Term Loading of Trussed Rafters with Different Connection Systems - T Feldborg and M Johansen
- 6-9-3 Deflection of Trussed Rafters under Alternating Loading during a Year - T Feldborg and M Johansen

#### CIB TIMBER CODE

- 2-100-1 Paper 2 A Framework for the Production of an International Code of Practice for the Structural Use of Timber - W T Curry
- 5-100-1 Design of Solid Timber Columns - H J Larsen
- 5-100-2 A Draft Outline of a Code of Practice for Timber Structures - L G Booth
- 6-100-1 Comments on Document 5-100-1; Design of Timber Columns - H J Larsen
- 6-100-2 CIB Timber Code: CIB Timber Standards - H J Larsen

#### LOADING CODES

- 4-101-1 Paper 19 Loading Regulations - Nordic Committee for Building Regulations
- 4-101-2 Paper 20 Comments on the Loading Regulations - Nordic Committee for Building Regulations

## STRUCTURAL DESIGN CODES

- 1-102-1 Paper 2 Survey of status of building codes, specifications etc, in USA - E G Stern
- 1-102-2 Paper 3 Australian codes for use of timber in structures - R H Leicester
- 1-102-3 Paper 4 Contemporary Concepts for structural timber codes - R H Leicester
- 1-102-4 Paper 9 Revision of CP 112 - First draft, July 1972 - British Standards Institution.
- 4-102-1 Paper 15 Comparison of Codes and Safety Requirements for Timber Structures in EEC Countries - Timber Research and Development Association
- 4-102-2 Paper 16 Nordic Proposals for Safety Code for Structures and Loading Code for Design of Structures - O A Brynildsen
- 4-102-3 Paper 17 Proposal for Safety Codes for Load-Carrying Structures - Nordic Committee for Building Regulations
- 4-102-4 Paper 18 Comments to Proposal for Safety Codes for Load-Carrying Structures - Nordic Committee for Building Regulations
- 4-102-5 Paper 21 Extract from Norwegian Standard NS 3470 "Timber Structures"
- 4-102-6 Paper 22 Draft for Revision of CP 112 "The Structural Use of Timber" - W T Curry

## INTERNATIONAL STANDARDS ORGANISATION

- 3-103-1 Paper 2 Method for Preparation of Standards Concerning the Safety of Structures - Published by International Standards Organisation (ISO/DIS 3250)
- 4-103-1 Paper 1 A Proposal for Undertaking the Preparation of an International Standard on Timber Structures - International Standards Organisation
- 5-103-1 Comments on the Report of the Consultation with Member Bodies concerning ISO/TS/P129 - Timber Structures - Dansk Ingeniorforening

## JOINT COMMITTEE ON STRUCTURAL SAFETY

- 3-104-1 Paper 1 International System of Unified Standard Codes of Practice for Structures - Published by Comité Européen du Béton (CEB)

## CIB PROGRAMME, POLICY AND MEETINGS

- 1-105-1 Paper 1 A note on international organisations active in the field of utilization of timber - P Sonnemans
- 5-105-1 The Work and Objectives of CIB-W18 - Timber Structures - J G Sunley

INTERNATIONAL COUNCIL FOR BUILDING RESEARCH STUDIES AND DOCUMENTATION  
WORKING COMMISSION W18 - TIMBER STRUCTURES

ON THE APPLICATION OF THE UNCERTAINTY THEORETICAL METHODS FOR THE  
DEFINITION OF THE FUNDAMENTAL CONCEPTS OF STRUCTURAL SAFETY

by

K SKOV and O DITLEVSEN

## 1. INTRODUCTION

Existing methods of structural design might well be providing adequate service to society, as they seem to do; although fundamental concepts of structural safety are not well defined. The absence of well-defined safety concepts leads to significant difficulties. At present there is no measure of the relative safety of structural elements such as beams and columns and so no measure of overall structural safety. Important questions, such as the relative safety of steel and concrete structures, or whether the safety of some elements can be reduced without affecting overall safety, cannot be answered with any confidence. When new information relevant to structural design is obtained, the proper use of such data can at best be established arbitrarily.

During the past few years a lot of work have been carried out for establishing a fundamental concept of structural safety. In an attempt to harmonize the safety concepts on an international level the ISO Technical Committee TC 98 has elaborated the ISO standard 2394 "General principles for the verification of the safety of structures", which was based on the work carried out in the "Joint Committee on Structural Safety" - CEB-ECCS-CIB-FIP-IASSE. The safety concept introduced in the mentioned ISO standard is based on characteristic values of actions and material properties in combination with partial safety coefficients related to the characteristic values, which more or less are defined by using the statistical distribution functions of the actions and the material properties. The method introduced by ISO is called the method of partial coefficient and is adopted by several countries for the verification of the safety of the structures. The ISO standard, however, is not defining the basic measure of structural safety.

It is, however, internationally acknowledged that there exists a need for a definition of the fundamental concepts of structural safety based on rational theories. If one accepts the idea,

introduced in the ISO standard, that the performance of structures is probabilistic, then it seems natural to define the fundamental safety concept by means of the mathematical probability concept. The definition of structural safety could then be that all structures, used for the same purpose, must have the same probability of entering into a given unwanted state.

The purpose of introducing a fundamental safety concept based on probabilistic design methods is to give a well-defined measure of structural safety, to take account of the development and those statistical observations, which already are available for the parameters involved in structural design and to serve as a basis for determination of the safety factors related to the method of partial coefficients in order to ensure that a uniform degree of safety, in terms of formal probabilities of failure is obtained.

It is, however, hardly ever possible to calculate the safety on the basis of distributions determined through physical observations. One reason is that the physical observations available are generally quite insufficient for the determination of the tails of the distributions (upper tails for loads and lower tails for resistance), these being almost decisive for the value of the failure probability. Another reason is - except for a few types of distribution - almost impracticable calculations from a mathematical and calculating point of view. In order to arrive at practical manageability, certain types of distribution might be standardized as an instrument for the verification of safety.

A standardization of this nature quite naturally leads to further simplification, as expressed in the uncertainty theoretical methods. Cp. [1], [2], [3], [4], [5] and [8].

A verification of the safety of a load carrying structure is in general based on an idealized model dealing with the action of the mechanical system. In resistance models, for instance, this

will for given values of the variables yield a resistance which deviates more or less from the resistance measured on the basis of a laboratory test with the structure element corresponding to the given values of the model variables.

The engineer's knowledge on material strengths normally comes from standardized measurements of the strengths of test specimens, which may deviate from the material strengths "in situ". To be added to this uncertainty is the uncertainty originating from any negligence on the construction site. The degree of uncertainty depends partly upon the work control carried out by the engineer. Moreover, such uncertainties may lead to geometrical deviations as for instance excentricities not being accounted directly for by the engineer, and which could not have revealed by means of laboratory tests.

Correspondingly, there exists a large number of not directly formulated uncertainties to a considered load effect. This is due to an idealized view on the load carrying structure and the way in which it transforms the exterior loads to the load effect in a certain spot of the structure. The uncertainty moreover originates from the idealization of the actual load distributions over the structure and in the time to identical or regularly distributed loads or single forces. Also loads, which physically can only with difficulty be considered uncertain quantities, may have to be considered uncertain. They could, for instance, be due to hypotheses concerning a future changed use of the structure.

The problem is the complications and limitations to our knowledge, which makes it impossible to set up exact mathematical models.

The engineer is forced to work with idealized models. Which however, he must not forget. Any matters which he cannot adapt to his model in details, he must acknowledge as adding to the uncertainties of the results which the model gives. Therefore

the engineer's evaluation - qualified but subjective - of this uncertainty is necessary for a design which is safe, but not so much on the safe side that materials from our limited resources are wasted.

It seems natural to try to evaluate uncertainties of the above nature by means of the mathematics of the uncertainty theory, i.e., by representing the various uncertainties by uncertain quantities. The engineer will then have to judge about the mean values and the coefficients of variation for these uncertain quantities. Sometimes it is possible to base the value of these quantities on objective measurements or professional analysis. In connection with a certain problem, for instance, a more detailed mathematical model could be used than will be used in the design process. The design model is, however, preferred because it is simple, and because it can be applied in connection with problems which are too complex to be analysed by the detailed model. The detailed model can, however, in connection with sample studies give information on uncertainties relating to the results from the design model (example: beam theory versus three-dimensional elasticity theory). The engineer's evaluation can in such situations be based on his professional insight into the detailed behaviour of the considered object.

Typical code specified formulae are often justified by experimental tests where the ability of the formulae to predict the behaviour of the specimens is judged. Such experiments are mostly made with specimens which are constructed with the closest possible resemblance to the idealized specimens covered by the formulae ("symmetrical" beam loaded in the "plane of symmetry" and supported on "simple" supports, straight centrally loaded columns, etc.). Practical construction on the site will inevitably lead to deviations from these ideal laboratory conditions. These deviations can in certain cases strengthen the structure and in certain cases weaken the structure. The experiences gathered by the engineer (or the engineering profession) from the inspection of real structures as well as his theoretical or experimen-

tal analysis of the consequences of the observed deviations from the idealized conditions are very important facts for the professional determination of the uncertainty.

The uncertainty may even refer to a quantity, which can only with difficulty, or not at all, be exposed to "repeated measurements". Repeated measurements may at least be excluded for practical reasons. An example are problems in connection with a special structure which has not yet been built, and which will only be constructed once. In the design phase for this structure, such "one-time-uncertainties" must, of course, be taken into consideration. Outside the engineering field this could be illustrated by means of a problem connected with some historical event: the historians' statements on such a problem will be subject a certain subjective uncertainty.

Uncertain quantities whose mean values and standard deviations are entirely or partly subject to subjective evaluations, are called the Bayesian Uncertain Quantities (Thomas Bayes, English priest, died 1761).

Turkstra (7) and Cornell (4) have suggested a simple model for the introduction of the Bayesian uncertain quantities into the safety evaluation of load carrying structures. Let  $M$  be a unsafe material strength included in the calculation model. Assume that the mean value  $E(M)$  and the coefficient of variation  $V_M$  have been given on the basis of a series of test results, under consideration to the statistical uncertainty which is due to the limited series of tests. This, however, does not allow for the total uncertainty of  $M$ . Therefore replace  $M$  by the  $MI$  where  $I$  is a Bayesian uncertain quantity (an evaluation factor) which may itself be a product of several of the Bayesian uncertain quantities. For instance, the equation can be set up  $I = FP$ , where  $F$  is a factor which allows for any manufacturing imperfectness in relation to the considered material and its role in the structure. The factor  $P$  covers the uncertainty in connection with the professional knowledge. It covers the

uncertainties which arise in connection with the set up of the model, and which could come from the idealization of the considered material's role for the failure mechanism. Moreover, it should partly cover the uncertainty in connection with the idealization of the influence the various materials may have on eachother. All the uncertain physical values included in the model may thus may be covered by the Bayesian factors, which account for this uncertainty. The uncertainty concerning the correction of the sample specimen strengths up to the strengths to be included in the calculation model, can also be covered by  $P$ . The Bayes factors can according to need be split up into more factors, if this simplifies the evaluation, according to which the mean value and the coefficient of variation is to be determined. Thus a factor could allow for any calculation errors which will not make themselves felt as serious errors.

When the values of  $E(F)$ ,  $E(P)$ ,  $V_F$ ,  $V_P$  have been determined in one way or another, the values of

$$E[M] E[F] E[P] \text{ and } \sqrt{V_M^2 + V_F^2 + V_P^2}$$

will be added, for  $E(M)$  and  $V_M$ , respectively. These rules were based upon the rules which are valid for products of mutually independent uncertain quantities.

Of course, this procedure is not a very detailed analysis. However, the purpose is also to allow for the uncertainties which are due to lack to detailed knowledge, and to avoid any extensive and difficult analysis in connection with the practical design work. The procedure has the advantage of pointing out this series of uncertainties and of leading to a distinct and rational discussion on these uncertainties, for instance in code committees. Finally, the formulae ensure a theoretically correct procedure for the combination of uncertainties, each of which is guessed by use of engineering judgment.

The resulting safety will then be estimated under consideration both to actually statistically fluctuating values and to the uncertainty found in the information which is at disposal. The safety must therefore be considered a credibility which for very

certain information can be interpreted as physical probability, and for very uncertain information must be interpreted as a value expressing the best obtainable professional judgment concerning safety. The last situation actually expresses more about the engineer's professional opinion about nature than about nature itself. The engineer's choice when determining the dimensions of a structure will, however, always be based on the observations available to him, as well as his professionally supported opinion about the qualities of the structure and its loads. The purpose of the mentioned safety model is merely to help the engineer from his basis of decisions which, when followed, ensures consistent and rational actions.

## 2. UNCERTAINTY THEORETICAL METHODS

An uncertainty theoretical method is a method based on the knowledge of mean values and standard deviations of the uncertain quantities which here are material strengths, loads, geometrical values, as well as parameters allowing for the uncertainty of design formulae, which must be included in the evaluation of the safety of a load carrying structure.

The idea of the method can be illustrated in the following way:

Assume that the design of a load carrying structure consists in the determination of the mean value of an uncertain parameter  $v$ , meeting the requirements for the safety of the structure. Assume that the structure will fail if  $v < 0$ .

Design, based on probability theory will consist in the determination of the mean value of  $v$ , in such a way that the probability of failure,  $P[v < 0] = \epsilon$ .

Generally we do not have sufficient data to determine which probability distributions are valid for the quantities used for the design of a load carrying structure. Moreover an evaluation based on probabilities of failure will generally lead to considerable calculatory difficulties.

The criterion of acceptance based on the failure probability  $P[v < 0] \leq \epsilon$  is therefore replaced by a more simple criterion involving only the mean value  $E[v]$  and the standard deviation  $D[v]$  the parameter  $v$ . This criterion, which is illustrated in figure 1, is

$$E[v] \geq \beta D[v] \quad (1)$$

where  $\beta$  is a coefficient that per definition is said to state the safety of the structure.  $\beta$  will in the following be referred to as the safety index.

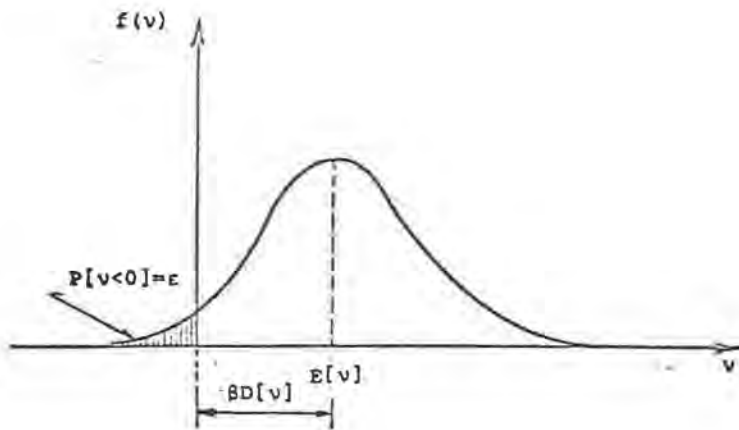

Figure 1. Illustration of the safety index  $\beta$ .

As is seen in figure 1, the distance from the mean value  $E[v]$  to the failure limit  $v=0$  measured in standard deviations  $D[v]$  can be defined as the safety index  $\beta$ .

If  $v$  is normally distributed, there exists a one to one relationship between the safety index  $\beta$  and the failure probability  $P[v<0]$  since this failure probability is defined as

$$P[v<0] = \Phi\left(-\frac{E[v]}{D[v]}\right) = \Phi(-\beta) \quad (2)$$

In this expression,  $\Phi$  represents the distribution function for the normal distribution. If, for instance,  $\beta=4.75$ , it follows that  $\Phi(-\beta) = 10^{-6}$ .

Generally, design of a load carrying structure involves more than one uncertain parameter. We may therefore generalize the definition of the safety index  $\beta$  to problems involving more than one uncertain parameter. For illustrative simplicity we restrict ourselves to the two-dimensional case since generalization to more variables is straight forward.

Assume for simplicity that the deterministic failure criterion is expressed in the equation

$$f(x, y) = ax + by + k = 0 \quad (3)$$

where

$a, b, k$  are constants with  $k>0$

and

$x$  and  $y$  are uncertain quantities,  $\xi$  and  $\eta$ , respectively with mean value

$$E[\xi] = D[\eta] = 0$$

and standard deviation

$$D[\xi] = D[\eta] = 1$$

The zero-point  $(0,0)$  is obviously in the safe domain. Thus the limit state expressed in (3) is reached or exceeded if and only if

$$f(x, y) = ax + by + k \leq 0 \quad (4)$$

The inequality (4) is now replaced by the equation

$$a(\xi - \alpha_x v) + b(\eta + \alpha_y v) + k = 0 \quad (5)$$

which defines an uncertain quantity  $v$ . In the equation (5)  $(-\alpha_x, \alpha_y)$  is a unit vector (termed the  $\alpha$ -vector) directed towards the failure side of the limit state line, see fig. 2. It is seen, that the limit state is defined for  $v=0$  and that the limit state is exceeded provided  $v<0$ . Thus we may define the safety index,  $\beta$ , by equation (1)

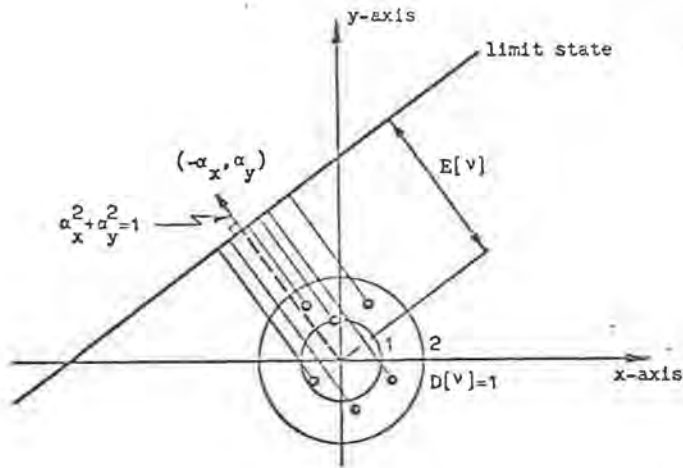

Fig. 2: Illustration of  $E[v]$  as being the distance from the origin of the reduced coordinate system to the limit state line. Each point corresponds to a random outcome of  $(\xi, \eta)$ , that is, a realization of the loaded structure.

$$\beta = \frac{E[v]}{D[v]}$$

measuring the distance from the mean  $E[v]$  to the limit state  $v=0$  in terms of the standard deviation  $D[v]$ . Solving (5) with respect to  $v$  yields

$$v = \frac{a\xi + b\eta + k}{aa_x - ba_y} \quad (6)$$

Since  $E[\xi] = E[\eta] = 0$  we get

$$E[v] = \frac{k}{aa_x - ba_y} \quad (7)$$

and since  $D[\xi] = D[\eta] = 1$  and assuming that  $\xi$  and  $\eta$  are uncorrelated we get

$$D[v] = \frac{\sqrt{a^2 + b^2}}{(aa_x - ba_y)} \quad (8)$$

If the  $\alpha$ -vector is selected such that it is perpendicular to the limit state line, that is

$$(-\alpha_x, \alpha_y) = - \frac{\left(\frac{\partial f}{\partial x}, \frac{\partial f}{\partial y}\right)}{\sqrt{\left(\frac{\partial f}{\partial x}\right)^2 + \left(\frac{\partial f}{\partial y}\right)^2}} = - \frac{(a, b)}{\sqrt{a^2 + b^2}} \quad (9)$$

it turns out that

$$D[v] = 1 \quad (10)$$

$$E[v] = \frac{k}{\sqrt{a^2 + b^2}} = \beta \quad (11)$$

and that  $\beta$  is the distance from the point  $(0,0)$  to the limit state line.

The above example illustrates the following geometrical definition of the safety index  $\beta$ :

"In a cartesian coordinate system with axes corresponding to mutually uncorrelated uncertain quantities reduced to mean value zero and standard deviation 1, the safety index  $\beta$  is the distance from the origin to the limit state line".

In cases of non-linear limit state line the safety index,  $\beta$ , is defined as being the shortest distance from the origin to the limit state line in the reduced coordinate system, see [8].

In practical design the uncertain quantities,  $X$ ,  $Y$ , have mean values and standard deviations different from zero and one respectively. In such cases we just introduce reduced variable, i.e. variables with mean values equal to 0 and standard deviation equal to 1, e.g.

$$x = \frac{X - E[X]}{D[X]} \quad \text{or} \quad x = \frac{\log X - E[\log X]}{D[\log X]} \quad (12)$$

$$y = \frac{Y - E[Y]}{D[Y]} \quad \text{or} \quad y = \frac{\log Y - E[\log Y]}{D[\log Y]}$$

As an example we may consider the failure criterion

$$X = Y \quad (13)$$

where  $X$  is the resistance of the structure and  $Y$  is the action effect.

The failure criterion (13) may equivalently be given as

$$\log X - \log Y = 0 \quad (14)$$

Using the logarithmic transformation in (12) equation (14) yields

$$D[\log X]x - D[\log Y]y + E[\log X] - E[\log Y] = 0 \quad (15)$$

This equation is equivalent to equation (3). Thus

$$\beta = \frac{E[\log X] - E[\log Y]}{\sqrt{D[\log X]^2 + D[\log Y]^2}} \quad (16)$$

If  $X$  and  $Y$  have a logarithmic normal distribution,  $v$  given by (6) has a normal distribution, thus defining the failure probability through (2).

Approximatively we have

$$\beta = \frac{\log \frac{E[X]}{E[Y]}}{\sqrt{V_R^2 + V_S^2}} \quad (17)$$

where  $V$  denotes the coefficients of variation.

### 3. THE INVARIANCE PROBLEM

In the preceding section, the idea behind the introduction of a safety index  $\beta$ , has been illustrated and an example dealing with resistance and load effect is given. As shown in [1] a safety index defined on the basis solely of means and standard deviations of resistance and load effect is, however, not unambiguously, that is, not invariant with respect to legal mathematical transformations.

The following example will illustrate the problem of invariance:

Suppose that the resistance is  $R$ , the load effect  $S$ , and that the limit state curve is given as

$$\log R < \log S \quad (18)$$

In this case, see equation (17), the safety, expressed in term of  $\beta_0$ , is given as

$$\beta_0 = \frac{\log \frac{E[R]}{E[S]}}{\sqrt{V_R^2 + V_S^2}} \quad (19)$$

The limit state, however, could also have been expressed by

$$\log R_1 < \log S_1 \quad (20)$$

where

$$R_1 = R + a \quad (21)$$

$$S_1 = S + a \quad (22)$$

in this case, the safety is given as

$$\beta_1 = \frac{\log \frac{E[R_1]}{E[S_1]}}{\sqrt{V_{R_1}^2 + V_{S_1}^2}} \quad (23)$$

In equation (18) the resistance  $R$  may for example denote the bending moment capacity with respect to the central axis of a reinforced concrete column cross-section, whereas the resistance  $R_1$  in equation (19) may denote the bending moment capacity with respect to the reinforcement center.

Assume that the parameter,  $a$ , is a constant. Then the following expressions are valid

$$E[R_1] = E[R] + a \quad (24)$$

$$E[S_1] = E[S] + a \quad (25)$$

$$V_{R_1} = \frac{E[R]}{E[R] + a} V_R \quad (26)$$

$$V_{S_1} = \frac{E[S]}{E[S] + a} V_S \quad (27)$$

For a given structure, that is, for given mean values,  $E[R]$  and  $E[S]$ , and coefficients of variation  $V_R$  and  $V_S$ , the safety expressed by  $\beta$  ought to be defined in a unique way. In the case considered we thus should require that  $\beta_0 = \beta_1$ . As shown in figure 3, this requirement is not fulfilled. It is seen, that  $\beta_1$ , for a fixed value of  $\beta_0$ , depends on the relative translation  $a/E[S]$ .

It should be emphasized that the invariance problem also appears in a deterministic code based on safety factors related to resistances and corresponding load effects, see [1].

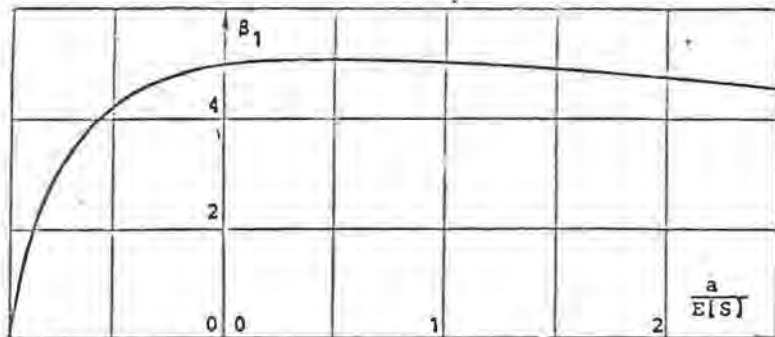

Figure 3. Illustration of translation dependence of the safety index  $\beta_1$ . (Determined for  $\beta_0 = 5$ ,  $V_R = V_S = 0.2$ ).

The invariance problem appears, as shown, in those cases where the resistance and the load effect are not defined in a unique way. It is, of course, possible in every single case to make code - standardized definitions of the resistance and the load effect.

This simply eliminates the possibility of using mathematically equivalent but formally different formulae. Performance of such a procedure is, however, clearly inconvenient and highly impracticable. A much more tractable way is by selecting a set of basic variables in terms of which all relevant quantities are given, see 8.

#### LITERATURE

- [1] Ditlevsen /1973/ Structural reliability and the invariance problem, University of Waterloo, Solid Mechanics Division, Report No. 22, March 1973.
- [2] Hasofer, Lind /1973/ An exact and invariant first-order reliability format, University of Waterloo, Solid Mechanics Division. Paper No. 119, Maj 1973.
- [3] Paloheimo, Hannus /1974/ Structural design based on weighted fractiles, Journal of the structural Division, ASCE, Vol. 100, No. ST7, July, 1974.
- [4] Cornell /1969/ A probability-based structural code, ACI-Journal, dec. 1969.
- [5] Rosenblueth and Esteva /1971/ Reliability Basis for Some Mexican Codes. Presented at the 1971 Annual Convention, ACI, Denver, March 1971.
- [6] Mayer /1926/ Die Sicherheit der Bauwerke, Springer Verlag, Berlin 1926.
- [7] Turkstra /1970/ Applications of Bayesian Decision Theory. Study No. 3: Structural Reliability and Codified Design. Solid Mechanics Division. Univ. of Waterloo. Waterloo, Ontario, Canada 1970.
- [8] Ditlevsen, Skov /1975/ The Uncertainty Theoretical Definition of Structural Safety Suggested by the NKB-Safety Committee, paper in preparation. Engineering Academy, Copenhagen, Denmark 1975.
- [9] Nordic Committee for Building Regulations (NKB), Sub-Committee on Structural Safety /1974/ Proposal for Safety Codes for Load-carrying Structures.

INTERNATIONAL COUNCIL FOR BUILDING RESEARCH STUDIES AND DOCUMENTATION  
WORKING COMMISSION W18 - TIMBER STRUCTURES

LATTICE COLUMNS

by

H J LARSEN  
Instituttet for Bygningsteknik  
Aalborg Universitetscenter  
Denmark

Comments to  
CIB-TIMBER STANDARD NO. 04, LATTICE COLUMNS

Reference is made to CIB-W18-document «The design of built-up timber columns» and CIB-Standard 04, from which the notations are taken. Since for lattice columns  $I_0 \ll I$  the effective moment of inertia is, cf. formula (44):

$$I_e \sim \frac{1}{1 + \mu} I \quad \text{supplement: } I_0 \approx \mu \cdot I_{\text{coll}} \quad (a)$$

i.e.

$$\lambda_e^2 = (1 + \mu) \lambda^2 \quad \lambda_e^2 = \lambda^2 + \mu \lambda^2 \quad (b)$$

$$\mu = \frac{\pi^2 A_f E}{\ell^2} \frac{a}{k} \quad (c)$$

For *V-trusses* cf. formula (50):

$$\frac{a}{k} = \frac{\ell_1}{2 \cos^2 \theta} \left[ \frac{\ell_1}{4EA_d \cos \theta} + \frac{1}{k_d} + \frac{\ell_1 e^2}{6EI_f} \left(1 - \frac{2e}{\ell_1}\right)^2 \sin^2 \theta \right] \quad (d)$$

For glued trusses the last term is normally dominating, i.e.

$$\frac{a}{k} \sim \frac{\ell_1^2 e^2}{12EI_f} \left(1 - \frac{2e}{\ell_1}\right)^2 \cdot \tan^2 \theta \sim \frac{\ell_1^2 e^2}{12EI_f} \tan^2 \theta \quad (e)$$

with  $I_f/A_f = i_f^2$  and  $2h = \ell_1 \tan \theta$

$$\mu = \frac{4\pi^2}{12} \left(\frac{e}{i_f}\right)^2 \left(\frac{h}{\ell}\right)^2 \quad (f)$$

Taking into account the first term in (d) by adding 25%

$$\mu \sim 4 \left(\frac{e}{i_f}\right)^2 \left(\frac{h}{\ell}\right)^2 \quad (g)$$

is found.

For nailed trusses the second term in (d) is dominating, i.e.

$$\frac{a}{k} \sim \frac{\ell_1}{2nk \cos^2 \theta} \quad (h)$$

$$\mu = \frac{\pi^2 A_f E}{\ell^2} \frac{\ell_1}{2nk \cos^2 \theta} = \frac{2\pi^2 A_f h E}{\ell^2 nk \sin 2\theta} \quad (i)$$

Taking into account the first term in (d) by adding 25%

$$\mu \sim 25 \frac{EA_f h}{\ell^2 nk \sin 2\theta} \quad (j)$$

is found.

For *N-trusses* formula (50) is replaced by

$$\frac{a}{k} = \frac{\ell_1}{\cos^2 \theta} \left[ \frac{1}{k_d} + \frac{\sin^2 \theta}{k_v} + \frac{\ell_1 e^2}{12EI_f} \left(1 - \frac{2e}{\ell_1}\right)^2 \sin^2 \theta \right] \quad (k)$$

In (k), where the terms taking into account the extension of diagonals and verticals are omitted,  $k_v$  is the stiffness of the joint between flange and vertical.

For glued trusses, with  $h = \ell_1 \tan \theta$ :

$$\frac{a}{k} \sim \frac{\ell_1^2 e^2}{12EI_f} \tan^2 \theta \sim \frac{h^2 e^2}{12EI_f} \quad (\ell)$$

$$\mu \sim \frac{\pi^2}{12} \left(\frac{\ell}{i_f}\right)^2 \left(\frac{h}{\ell}\right)^2 \quad (\text{m})$$

Adding 25%:

$$\mu \sim \left(\frac{\ell}{i_f}\right)^2 \left(\frac{h}{\ell}\right)^2 \quad (\text{n})$$

For nailed trusses taking  $k_d \sim k_v / \sin^2 \theta$ :

$$\frac{a}{k} \sim \frac{2\ell_1}{\cos^2 \theta nk} \quad (\text{p})$$

Again adding 25%:

$$\mu \sim 50 \frac{EA_f h}{\ell^2 nk \sin 2\theta} \quad (\text{q})$$

is found.

INTERNATIONAL COUNCIL FOR BUILDING RESEARCH STUDIES AND DOCUMENTATION  
WORKING COMMISSION W18 - TIMBER STRUCTURES

A MATHEMATICAL BASIS FOR DESIGN AIDS FOR TIMBER COLUMNS

by

H J BURGESS  
Timber Research and Development Association  
United Kingdom

Aalborg, Denmark - June 1976

## CONTENTS

	<u>Page No.</u>
Introduction	1
COLUMN WITH LONGITUDINAL LOAD ONLY	2
Derivation of Perry formula	2
Deflection	3
INITIALLY CURVED COLUMN WITH UNIFORM LATERAL LOAD	5
Combined stress equation	6
Approximations for stress	7
Deflection	7
Plotting of chart	9
References	10

## A MATHEMATICAL BASIS

### FOR DESIGN AIDS FOR TIMBER COLUMNS

Design aids for solid timber beams have been produced in various forms, but little has been published to assist in the design of timber columns, partly because of the much greater complexity of the mathematics describing the behaviour of both ideal and practical columns. Ideally, a design chart for columns, especially those with lateral load, should allow for a limitation on deflection as well as a stress limitation. This has been achieved for solid timber beams as shown by Fig.1; the key diagram at the left of the chart shows how it is used.

It is too much to hope that a chart of such wide application can be devised for columns because of the fundamentally different mathematical description of their behaviour, but trials have found forms of chart applicable to a single timber which can greatly speed the process of selecting a member of adequate size for given longitudinal and lateral loads.

The object of this paper is to propose one mathematical basis for such charts, allowing for deflection as well as stress limitations. Most of the work comprises a development of results in the conventional theory of elasticity although approximations of simpler form may appear in a Code of Practice and may if desired be incorporated in design charts. In such cases it is important to know what more precise theory is being approximated so that an idea of the loss of accuracy may be gained. Also, a design chart may if desired be based on the precise theory from which the approximation is derived; the chart would not be in conflict with an approximate formula provided for ease of calculation, and it would generally be unsatisfactory to adopt the same approximation for the graphical method.

An important reason for keeping to the precise method is that it reduces to the usual result for a beam when the longitudinal load is zero, or to the result for a column when the lateral load is zero. Some approximations do not achieve this, and moreover tend to give a very misleading impression of the behaviour of beam-columns. For example approximations containing a factor  $(1 - \frac{P}{P_c})$  tend to give the impression that there is an equilibrium solution with  $P = P_c$  when in fact there is not. Such a mistake would not be made by the person deriving the approximation or by one who has studied the derivation closely, but many users of a code of practice will not be in this position.

The following work will be concerned with formulae developed from the assumptions leading to the "Perry formula". This is applicable to a column with initial sinusoidal curvature and the effects of defects, inhomogeneity and accidental eccentricity of the load are taken into account by an additional curvature. The validity of the method has been debated in text-books and elsewhere (c.g. Pearson 1954) and will not be discussed here. Similarly no consideration will be given to the merits of the competing "secant formula" which has been adopted in Australia, or of a method used in continental Europe which has been described in two recent papers by Larsen (1973).

#### COLUMN WITH LONGITUDINAL LOAD ONLY

##### Derivation of Perry formula

The above assumptions lead to the following formula for the maximum deflection of a column carrying only longitudinal load when the total initial 'curvature' corresponds to an initial deflection  $a$

$$y = \frac{a}{1 - \frac{c}{p_e}}$$

where  $c = \frac{P}{A}$  is the nominal compressive stress and  $p_e$  is the Euler stress  $\pi^2 E / (l/r)^2$ .

The maximum stress occurs on the concave face with the value

$$\frac{P}{A} + \frac{P y h}{A r^2}$$

where  $h$  is the distance from the neutral axis to the concave face.

If this stress is not to exceed the grade stress  $c_g$ , then putting

$$c = \frac{P}{A} \text{ and } \eta = a h / r^2,$$

$$c_g = c \left\{ 1 + \frac{\eta c}{p_e} \right\} \quad (1)$$

This quadratic equation is solved for  $c$  to give the Perry formula

$$c = \frac{1}{2} \{ c_g + (1 + \eta) p_e \} - \sqrt{\left\{ \frac{1}{2} c_g + \frac{1}{2} (1 + \eta) p_e \right\}^2 - c_g p_e} \quad (2)$$

In this case where the value of  $c$  is such that the limiting stress  $c_g$  is reached,  $c$  is usually called  $c_p$  and the  $K_{18}$  factor of CP112 is derived as

$$K_{18} = \frac{c_p}{c_g} = 0.5 + 0.5 (1 + \eta) \frac{p_e}{c_g} - \sqrt{\left\{ 0.5 + 0.5 (1 + \eta) \frac{p_e}{c_g} \right\}^2 - \frac{p_e}{c_g}}$$

This well-known formula is adopted in the U.K. as a suitable basis

for the design of timber columns. Its brief derivation has been given because similarities will be pointed out later in formulae suggested for the design of laterally loaded columns, which will reduce to the Perry formula when the lateral load is zero.

### Deflection

With  $\alpha = \frac{c}{P_e}$  the maximum deflection of the loaded column is

$$y = \frac{a}{1-\alpha}$$

and the additional deflection due to loading is found by deducting  $a$  from this to give

$$\frac{a}{1-\alpha} - a = \frac{a\alpha}{1-\alpha}$$

If this additional deflection is to be limited to  $\delta$  then

$$\delta = \frac{a\alpha}{1-\alpha}$$

Usually  $\delta$  is available as a fraction such as 0.003 of the height  $l$  so that  $\frac{\delta}{l} = 0.003 = \delta'$ . Similarly  $a$  is usually available as a fraction of  $l$  since for example the expression  $\eta = 0.005 \frac{l}{r}$  implies  $a = 0.00289l$ , and this fraction will be termed  $a' = \frac{a}{l}$ .

Thus the above equation may alternatively be expressed as

$$\frac{\delta}{l} = \frac{a\alpha}{l(1-\alpha)}$$

$$\text{or } \delta' = \frac{a'\alpha}{1-\alpha}$$

Using the first form with  $\alpha$  replaced by  $\frac{P}{P_e}$  gives

$$\frac{P}{P_e} = \frac{\delta}{a+\delta}$$

so  $P$  is limited by deflection to  $\frac{P_e \delta}{a+\delta}$

or  $c = \frac{P}{A}$  is limited to  $\frac{P_e \delta}{a+\delta}$  (3)

The stress on the concave face is

$$c_v = c \left( 1 + \frac{n}{1-\alpha} \right)$$

$$= \frac{P_e \delta}{a+\delta} \left[ 1 + \frac{6 \frac{a}{d}}{1 - \frac{\delta}{a+\delta}} \right]$$

$$= P_e \delta \left[ \frac{1}{a+\delta} + \frac{6}{d} \right]$$

for a rectangular section

(4)

This is the maximum stress when deflection governs the design. When stress is the governing criterion, the limiting value of  $c$  is found by the Perry formula as the solution of

$$c_g = c \left( 1 + \frac{6 \frac{a}{d} c}{1 - \frac{c}{k_e}} \right)$$

If the limitations applied to deflection and stress take effect simultaneously, i.e. at the changeover between the deflection-governed and stress-governed regions, the value of  $c$  given by (1) may be inserted in (4) to give

$$c_g = k_e \delta \left[ \frac{1}{a + \delta} + \frac{6}{d} \right]$$

- but the same may be seen immediately from (4) since at the changeover point not only will  $c_v$  be limited to this value by deflection but also the stress on the concave face ( $c_v$ ) will simultaneously be limited to  $c_g$ .

Inserting

$$k_e = \frac{\pi^2 E}{12} \left( \frac{d}{l} \right)^2$$

and the values  $\delta' = \frac{\delta}{l}$  and  $a' = \frac{a}{l}$  which are usually known rather than  $\delta$  and  $a$ ,

$$c_g = \delta' \frac{\pi^2 E}{12} \left( \frac{d}{l} \right)^2 \left[ \frac{1}{a' + \delta'} + 6 \frac{l}{d} \right]$$

This is a quadratic in  $\frac{d}{l}$  which may be solved taking the positive root to give

$$\frac{d}{l} = 3(a' + \delta') \left[ \sqrt{1 + \frac{4}{3\pi^2 E} \frac{c_g}{\delta'(a' + \delta')}} - 1 \right]$$

as the  $\frac{d}{l}$  value at which the changeover takes place between the deflection-governed and stress-governed regions.

INITIALLY CURVED COLUMN WITH UNIFORM LATERAL LOAD

The formal solution for an initially curved column with uniform lateral load may be found easily by the modified superposition method explained by Timoshenko and Gere (1961), combining the deflection for a curved column with no lateral load with that for an initially straight column carrying lateral load to give

$$y = \frac{a}{1-\alpha} + \frac{5ql^4}{384EI} \eta(u) \quad \text{--- (5)}$$

where

$$\eta(u) = \frac{12(2 \sec u - 2 - u^2)}{5u^4} \quad \text{with } u = \frac{kl}{2} \text{ and } k = \sqrt{\frac{P}{EI}}$$

$$\text{or } u = \frac{\pi}{2} \sqrt{\frac{P}{P_e}}$$

and  $\alpha$  = 'deflection' present before loading, representing the assumed initial curvature including the effect of defects and accidental eccentricity as well as the actual curvature.

The bending moment at the centre is

$$M = Py + \frac{ql^2}{8}$$

$$= \frac{Pa}{1-\alpha} + \frac{ql^2}{8} \lambda(u) \quad \text{when the value of } y$$

is inserted, where

$$\lambda(u) = \frac{2(1 - \cos u)}{u^2 \cos u}$$

The first term is the result for a curved column without lateral load as given above and the second term is the result for a lateral load on a straight column.

Following the method used in deriving the Perry formula,

$$\text{Max. stress} = \frac{P}{A} + \frac{Pa}{(1-\alpha)} \frac{h}{Ar^2} + \frac{ql^2}{8} \frac{\lambda(u)h}{Ar^2}$$

$$= c + \frac{c\eta}{1-\alpha} + \frac{ql^2}{8} \frac{\lambda(u)h}{Ar^2}$$

With  $\frac{h}{Ar^2} = \frac{6}{bd^2}$  for rectangular members and putting  $\frac{q}{b} = \omega$ , then if the maximum stress is to be limited to  $c_y$  for example,

$$c_y = c \left( 1 + \frac{\eta}{1-\alpha} \right) + \frac{3}{4} \frac{\omega l^2}{d^2} \lambda(u) \quad \text{(6)}$$

in which  $\eta$  may be replaced by  $6\frac{\alpha}{d}$  because the expression is now restricted to rectangular members.

Equation (6) is to be solved for  $c$  given  $w$  or for  $w$  given  $c$ .

Presuming  $c$  cannot be found explicitly,  $w$  can be found for a range of  $c$  values from the transposed form

$$w = \frac{4}{3} \left( \frac{d}{l} \right)^2 \frac{1}{\lambda(u)} \left[ c_g - c \left\{ 1 + \frac{\eta}{1 - \frac{c}{P_e}} \right\} \right] \quad (7)$$

A chart displaying these values will of course allow  $c$  to be found when  $w$  is known, as easily as the reverse case.

When  $w=0$ ,  $c_g = c \left[ 1 + \frac{\eta}{1 - \frac{c}{P_e}} \right]$  giving  $c = c_f$ , the result for a column without lateral load in equation (2)

When  $c=0$ ,  $w = \frac{4}{3} \left( \frac{d}{l} \right)^2 c_g$ , putting  $\lambda(u)=1$  when  $c=0$ .

This is the usual result for a beam without longitudinal load except that  $c_g$  appears instead of  $f_p$  since equation (6) limits the stress on the concave face to  $c_g$  in all cases.

#### Combined stress equation

If it is desired to vary the maximum stress on the concave face from  $f_p$  to  $c_g$  as  $c$  ranges from 0 to  $c_f$ , this can be done by changing (6) to the "combined stress" form thus:

$$1 = \frac{c}{c_g} \left\{ 1 + \frac{\eta}{1 - \frac{c}{P_e}} \right\} + \frac{3}{4} \frac{w d^2}{d^2} \frac{\lambda(u)}{f_p} \quad (8)$$

If  $w$  is plotted against  $c$  from (7), the use of equation (8) is equivalent to relabelling the vertical axis with values increased in the ratio  $\frac{f_p}{c_g}$ . Then the mathematical relationship in (8) means that  $\frac{c_g}{f_p}$  times the values on the vertical axis must be taken before entering equation (7) derived from (6). Equation (8) yields the Perry result when  $w=0$  and the ordinary result for a beam when  $c=0$ . A method described by Larsen applies a "combined stress" equation even to a column without lateral load, so that with  $w=0$  the constituent  $\frac{c\eta}{1 - \frac{c}{P_e}}$  of equation (6), arising from the bending moment caused by the longitudinal load, is divided by  $f_p$  instead of  $c_g$ . This procedure is in conflict with the traditional UK method where solving the equation

$$c_g = c \left\{ 1 + \frac{\eta}{1 - \frac{c}{P_e}} \right\}$$

to obtain the Perry formula implies that both the constituents  $c$  and  $\frac{c\eta}{1 - \frac{c}{P_e}}$  are divided by  $c_g$ . The method applied by Larsen cannot produce an equation which reduces to the Perry result when  $w=0$ . It is suggested that with the lateral deflection limited when  $w=c$ , the stress distribution is essentially compressive and there is little justification for applying a combined stress equation which is not a mathematically derived equation and in British practice is only a convenient way of obtaining the stresses  $f_p$  when  $c=0$  and  $c_g$  when  $w=0$  in laterally loaded columns.

Approximations for stress

If  $u = \frac{\pi}{2} \sqrt{\frac{P}{P_c}}$  is not too large, the approximation

$$\lambda(u) = \frac{1}{1-\alpha} \quad \text{may be adopted.}$$

Then (6) may be written as

$$c_3 = c + \frac{c\eta}{1-\frac{c}{P_c}} + \frac{f_a}{1-\frac{c}{P_c}} \quad (9)$$

which may be solved for  $c$  to give the positive root

$$c = \frac{1}{2} \left\{ c_3 + (1+\eta) \frac{P_c}{2} \right\} + \sqrt{\left\{ \frac{c_3 + (1+\eta)P_c}{2} \right\}^2 - (c_3 - f_a)P_c} \quad (10)$$

This is very similar to the Perry solution (2), the only difference being that the second term under the square root sign has changed from  $-c_3 P_c$  to  $-(c_3 - f_a) P_c$ .

However the Perry formula was exact whereas (9) is an approximation.

If on the other hand the constituent  $\frac{c\eta}{1-\frac{c}{P_c}}$  of (9) is divided by  $f_r$  as well as the constituent arising from lateral load, the same approximation for  $\lambda(u)$  yields

$$c = \frac{1}{2} \left\{ c_3 + \left(1 + \frac{c_1}{f_r} \eta\right) P_c \right\} + \sqrt{\left\{ \frac{1}{2} c_3 + \frac{1}{2} \left(1 + \frac{c_1}{f_r} \eta\right) P_c \right\}^2 - \left\{1 - \frac{f_a}{f_r}\right\} c_3 P_c}$$

Again, this does not reduce to the Perry formula when  $f_a = 0$ , whereas the preceding expression does.

Deflection

Equation (5) gave the final 'deflection' of an initially curved column carrying lateral as well as longitudinal load. The initial curvature with a central deflection  $\alpha$  includes the effect of defects and accidental eccentricity as well as the actual curvature. The increase of deflection caused by the load is found by deducting the initial value  $\alpha$ , and if this increase is limited to  $\delta$ , then

$$\delta = \frac{\alpha \alpha}{1-\alpha} + \frac{5q_0 l^4}{384 EI} \eta(u) \quad (11)$$

Inserting  $\delta' = \frac{\delta}{l}$  and  $a' = \frac{a}{l}$  as before, this gives

$$\omega = \frac{32E}{5} \left(\frac{d}{l}\right)^3 \frac{1}{\eta(u)} \left[ \delta' - \frac{a'}{\frac{p_e}{c} - 1} \right] \quad (12)$$

where  $\omega = \frac{q_i}{b}$  and the equation now refers to rectangular sections.

When  $c = 0$ ,  $\omega = \frac{32E\delta'}{5}$  since  $\eta(u)$  may be replaced by 1 or with

$\delta' = 0.003$ ,  $\omega = \frac{12}{625} E \left(\frac{d}{l}\right)^3$ , the familiar solution for a uniformly - loaded beam.

When  $\omega = 0$ ,  $\eta(u) = \infty$  is not a solution with  $c = \frac{p_e}{2}$  because

$$\delta' - \frac{a'}{\frac{p_e}{c} - 1} = -\infty \quad \text{when } c = \frac{p_e}{2}$$

The smallest solution is obtained from

$$\delta' - \frac{c a'}{\frac{p_e}{2} - c} = 0$$

giving  $c = \frac{\delta'}{a' + \delta'} \frac{p_e}{2}$

as in equation (3) for the column without lateral load.

The close approximation  $\eta(u) = \frac{1}{1-\alpha}$  may be applied to (12) to give

$$\omega = \frac{32E\delta'}{5} \left(\frac{d}{l}\right)^3 - \frac{384}{5\pi^2} (a' + \delta') c \left(\frac{d}{l}\right) \quad (13)$$

This may lead to a very simple design procedure when deflection governs the calculation. For example with  $\delta' = 0.003$  and  $a' = 0.00289$  corresponding to

$\eta = 0.005 \frac{l}{r}$ , the equation yields

$$\omega = \frac{12}{625} E \left(\frac{d}{l}\right)^3 - 0.0458 p$$

Where  $p = c \left(\frac{d}{l}\right)$  is the longitudinal loading expressed per unit of lateral area. Thus the permissible lateral load is the usual value for lateral load alone diminished by a simple multiple of  $p$ .

### Plotting of chart

For an initially-curved column without lateral load, an expression was found for the value of  $d/l$  at which the changeover takes place between the deflection-governed and stress-governed sections of the curve showing the relation between  $d/l$  and the permissible average longitudinal stress,  $c$ .

For laterally-loaded columns, equation (8) is applicable in the stress-governed region and equation (12) in the deflection-governed region. The value of  $d/l$  at which the the changeover takes place cannot be found algebraically but is evident when both relationships are plotted and superimposed. To prepare a design chart, either the relevant portions of the two sets of computer-plotted curves are traced off, or the computer program is arranged to draw only the relevant portions by storing both sets of curves but plotting the lower of the two  $\omega$  values stored for each value of  $c$ . Both sets of curves are shown in the example in Fig.2.

Equations (8) and (12) are restricted to members with a rectangular section. In fact the use of  $\omega = \frac{q}{b}$  implies the lateral load is expressed per unit of lateral area. Similar results are evident for non-rectangular cases, but note should be taken of the possibility that the tension side is critical (Larsen 1973).

References

1. Pearson, R.G., 1954 - The secant approximation and the Perry formula; expressions for eccentrically-loaded struts. *Engineering*, 178, 4632, Nov.1954.
2. Larsen, H.J., 1973 - The design of solid timber columns. Paper for CIB Working Commission W18, Sept.1973 (meeting in Copenhagen, Sep.1973).
3. Larsen, H.J., 1973 - Calculation of timber beams subjected to bending and normal force. Paper for CIB Working Commission W18, Oct.1973 (meeting in Paris, Feb.1975).
4. Timoshenko, S.P. and J.M. Gere, 1961 - *Theory of Elastic Stability*, 2nd Edition, McGraw-Hill 1961.

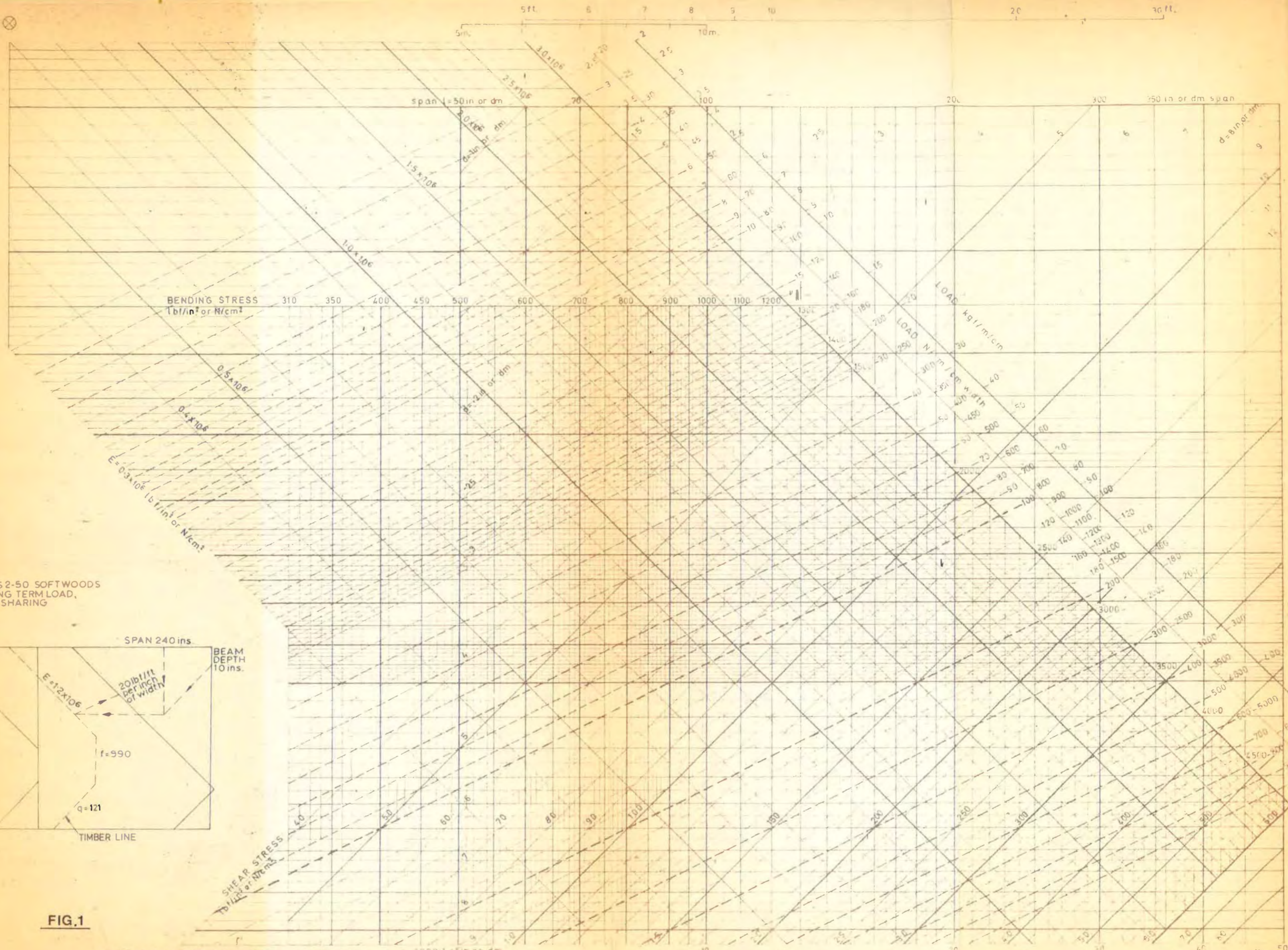

EXAMPLE - S2-50 SOFTWOODS  
AIR DRY, LONG TERM LOAD,  
WITH LOAD-SHARING

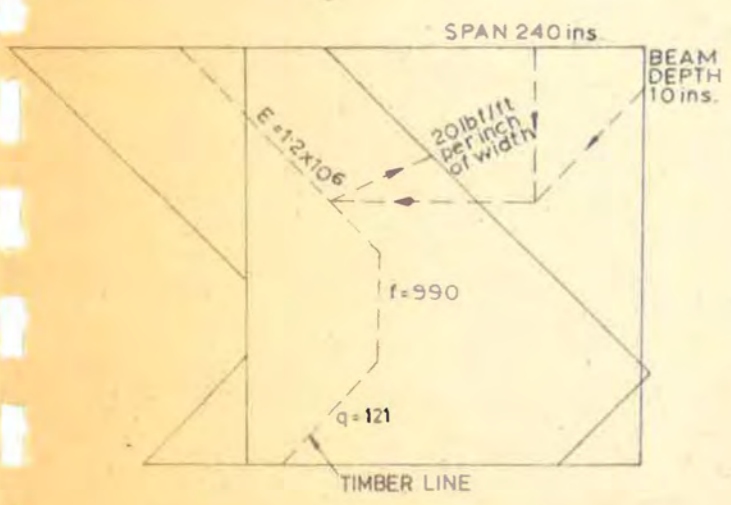

FIG.1

UNIVERSAL SPAN CHART

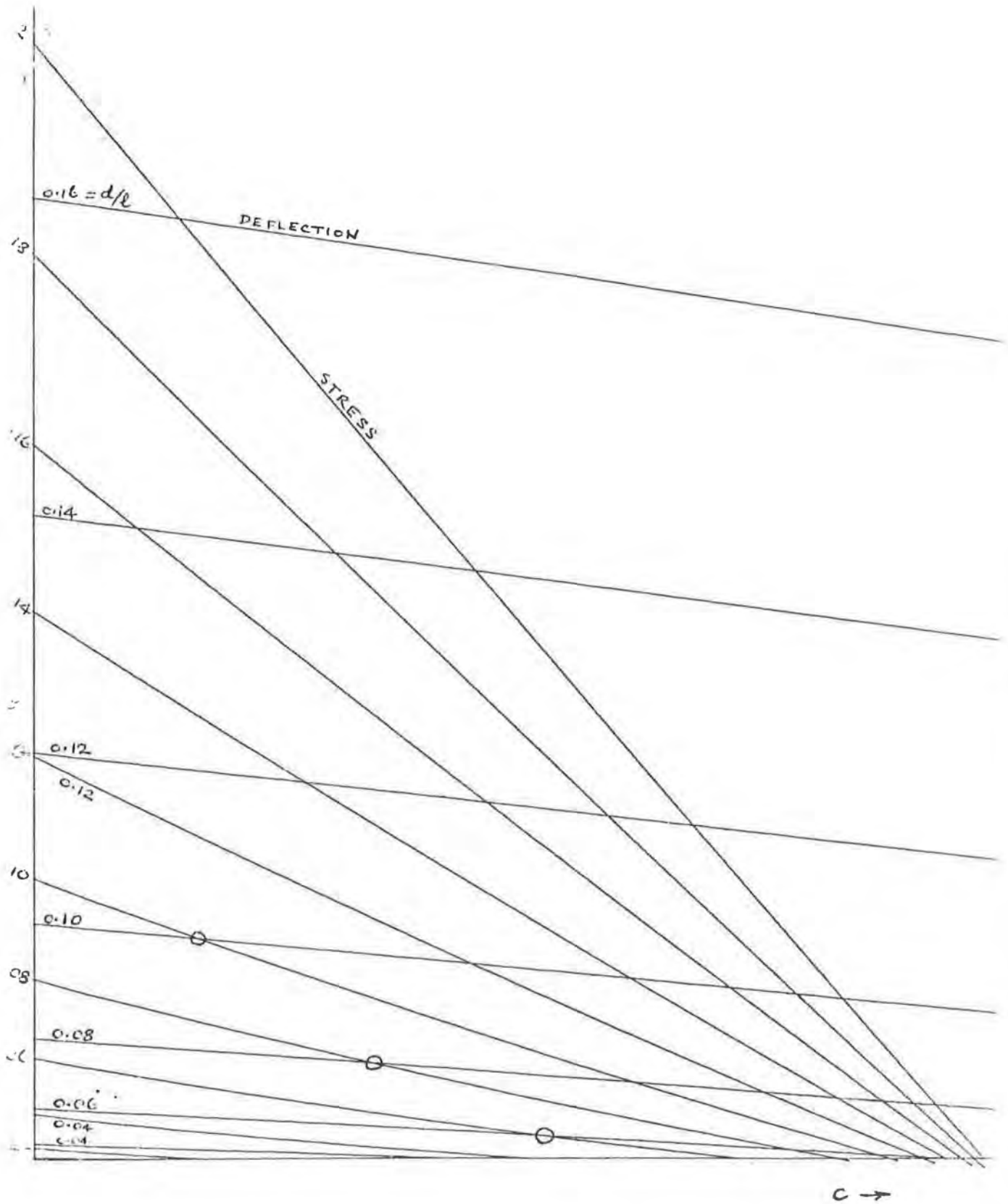

FIG. 2

C48 COMBOX

Lehrstuhl für  
 Ingenieurholzbau u. Baukonstruktionen.  
 Universität (TH) Karlsruhe  
 Prof. Dr.-Ing. K. Möhler

INTERNATIONAL COUNCIL FOR BUILDING RESEARCH STUDIES AND DOCUMENTATION  
WORKING COMMISSION W18 - TIMBER STRUCTURES

COMPARISON OF LARSEN AND PERRY FORMULAS FOR SOLID TIMBER COLUMNS

by

H J BURGESS  
Timber Research and Development Association  
United Kingdom

Aalborg, Denmark - June 1976

## CONTENTS

	<u>Page No.</u>
DERIVATION OF LARSEN FORMULA	1
Long column	2
Larsen formula based on $c_y$ instead of $c_x$	3
DERIVATION OF PERRY FORMULA AND MODIFIED FORM	4
REDUCTION OF LARSEN FORMULA TO MODIFIED PERRY FORM	6
TREATMENT OF END ECCENTRICITY IN THE TWO METHODS	6
Perry method	7
Larsen method	7
Reconciliation of the two methods	7
RECONCILIATION OF PERRY AND LARSEN FORMULAE	9

Comparison of Larsen and Perry formulas  
for solid timber columns

DERIVATION OF LARSEN FORMULA

In a very short column ( $\lambda \rightarrow 0$ ) carrying a longitudinal load  $P$  with eccentricity  $e_1$ , the maximum stress occurs on the compressive side with the value

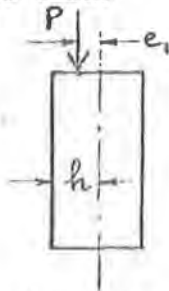

$$\frac{P}{A} + \frac{Pe_1 h}{Ar^2} = \frac{P}{A} + \frac{Pa}{A}$$

$$\text{where } a = \frac{e_1 h}{r^2} = \frac{e_1 h}{r^2}$$

Suppose the maximum stress is to be limited not to the compressive grade stress  $c_g$  but to the somewhat higher value implied by the 'combined stress' formula

$$\frac{c_o}{c_g} + \frac{c_o a}{f_p} = 1$$

where  $c_o =$  permissible  $\frac{P}{A}$  at  $\lambda = 0$  and is the same as Larsen's  $\Delta_c$  as the following will show,

$$\text{then } c_o = \frac{c_g f_p}{f_p + a c_g} \quad (1)$$

The basic combined stress formula given in Larsen's (7) is

$$\frac{c_a}{c_g} + \frac{f_a}{f_p} = 1 \quad (2)$$

If it is desired to base this on  $c_o$  instead of  $c_g$ ,

$$\text{from (1), } c_o f_p + a c_o c_g = c_g f_p$$

$$c_g = \frac{c_o f_p}{f_p - a c_o}$$

$$\frac{c_a}{c_g} = \frac{c_a (f_p - a c_o)}{c_o f_p} = \frac{c_a}{c_o} \left(1 - a \frac{c_o}{f_p}\right)$$

and inserting this in (2),

$$\left(1 - a \frac{c_o}{f_p}\right) \frac{c_a}{c_o} + \frac{f_a}{f_p} = 1 \quad (3)$$

- which agrees with Larsen's (8)

Long column

Larsen's (4) was

$$\text{Deflection } y = e \frac{k_E}{k_E - \frac{C_0}{C_0}}$$

where  $e = e_1 + e_2$  is the total initial eccentricity

$$k_E = \text{Euler stress } \pi^2 E / \lambda^2$$

$$\begin{aligned} \text{so } f_a &= \frac{P y}{Z} = \frac{P y h}{A r^2} = C_a y \frac{h}{r^2} \\ &= C_a \frac{h}{r^2} e \frac{k_E}{k_E - \frac{C_0}{C_0}} \\ &= C_a E \frac{k_E}{k_E - \frac{C_0}{C_0}} \end{aligned}$$

$$\text{since } \epsilon = \frac{e h}{r^2} = \epsilon_1 + \epsilon_2 = \frac{e_1}{k} + \frac{e_2}{k} = a + b \lambda$$

Inserting  $f_a$  in (3)

$$\left(1 - a \frac{C_0}{f_p}\right) \frac{C_a}{C_0} + \frac{C_a}{f_p} E \frac{k_E}{k_E - \frac{C_0}{C_0}} = 1$$

writing  $1 - a \frac{C_0}{f_p} = \psi$ ,  $\beta = \frac{C_0}{f_p}$  giving  $\frac{C_a}{f_p} = \frac{C_a}{C_0} \frac{C_0}{f_p} = \beta \frac{C_a}{C_0}$ ,

$$\psi \frac{C_a}{C_0} + \beta \frac{C_a}{C_0} E \frac{k_E}{k_E - \frac{C_0}{C_0}} = 1$$

Solving for  $\frac{C_a}{C_0}$  and expressing the result as  $\frac{C_p}{C_0}$ ,

$$\frac{C_p}{C_0} = \frac{1 + (\psi + \beta E) k_E}{2 \psi} - \sqrt{\left[ \frac{1 + (\psi + \beta E) k_E}{2 \psi} \right]^2 - \frac{k_E}{\psi}} \quad \text{--- (4)}$$

- which is Larsen's equation (12).

The most important thing to point out is that the value  $C_0$ , shown as  $\Delta_c$  in Larsen's symbols, is not the compressive strength of the material as derived from tests on small specimens. It has the value

$$C_0 = \frac{C_1 f_p}{f_p + a C_1}$$

$$\text{where } a = \frac{e_1}{k} = \frac{e_1 h}{r^2}$$

Larsen formula based on  $c_g$  instead of  $c_e$

Larsen's results may alternatively be expressed in terms of  $c_g$  instead of introducing  $c_e$ . The combined stress expression (2) was

$$\frac{c_a}{c_g} + \frac{f_a}{f_r} = 1$$

Inserting

$$f_a = c_a \frac{y h}{r^2}$$

and  $y = \frac{e_1 + e_2}{1 - \frac{c_a}{p_e}}$  from Larsen's (4),

$$\frac{c_a}{c_g} + \frac{c_a}{f_r} \frac{h}{r^2} \frac{(e_1 + e_2)}{1 - \frac{c_a}{p_e}} = 1$$

$$\frac{c_a}{c_g} + \frac{c_a}{f_r} \epsilon \frac{1}{1 - \frac{c_a}{p_e}} = 1$$

$$\frac{c_a}{c_g} + \frac{c_a}{c_g} \frac{c_g}{f_r} \epsilon \frac{1}{1 - \frac{c_a c_g}{c_g p_e}} = 1$$

Solving for  $\frac{c_f}{c_g}$  and expressing the result as  $\frac{c_f}{c_g}$  gives

$$\frac{c_f}{c_g} = \frac{1}{2} + \frac{1}{2} \left( 1 + \frac{c_g}{f_r} \epsilon \right) \frac{p_e}{c_g} - \sqrt{\left[ \frac{1}{2} + \frac{1}{2} \left( 1 + \frac{c_g}{f_r} \epsilon \right) \frac{p_e}{c_g} \right]^2 - \frac{p_e}{c_g}} \quad (5)$$

as the alternative form of equation (4) above.

By making the substitutions

$$c_o = \frac{c_g f_r}{f_r + a c_g}$$

$$\psi = 1 - a \frac{c_o}{f_r} = \frac{f_r}{f_r + a c_g}$$

$$\beta = \frac{c_o}{f_r} = \frac{c_g}{f_r + a c_g}$$

$$\text{and } k_e = \frac{p_e}{c_o} = \frac{p_e (f_r + a c_g)}{c_g f_r}$$

it may be shown that (4) reduces to (5). That is the two equations are mathematically identical and transformable to each other. Also since

$$\frac{c_f}{c_o} = \frac{c_f}{c_g} \times \frac{(f_r + a c_g)}{f_r}$$

equation (4) may be expressed in this form,  $\frac{c_f}{c_g}$  being given by equation (5).

$$\text{i.e. } \frac{c_f}{c_o} = \frac{c_f}{c_g} \left( 1 + a \frac{c_g}{f_r} \right)$$

is the same as Larsen's equation (12), or alternatively

$$\psi \frac{c_f}{c_o} = \frac{c_f}{c_g}$$

where  $\frac{c_f}{c_g}$  is given by (5) above.

DERIVATION OF PERRY FORMULA AND MODIFIED FORM

The derivation of the Perry formula was given in a previous paper\* as follows, applying to a column with initial sinusoidal curvature. The effects of defects, inhomogeneity and accidental eccentricity of the load are taken into account by an additional curvature. If the total 'curvature' corresponds to an initial deflection 'a', the maximum deflection under a longitudinal load P is

$$y = \frac{a}{1 - \frac{c_c}{P_e}}$$

where  $c_c = \frac{P}{A}$  is the nominal compressive stress and  $P_e$  is the Euler load  $\pi^2 E / \lambda^2$ .

The maximum stress occurs on the concave face with the value

$$\frac{P}{A} + \frac{P y h_c}{A r^2}$$

where  $h_c$  is the distance from the neutral axis to the concave face. If this stress is not to exceed the grade stress  $c_g$ , then putting  $c_c = \frac{P}{A}$  and  $\eta = \frac{a h_c}{r^2}$ ,

$$c_g = c_c \left\{ 1 + \frac{\eta}{1 - \frac{c_c}{P_e}} \right\} \quad \text{--- (6)}$$

This quadratic equation is solved for c to give the Perry formula, the solution being given the symbol  $c_p$ :

$$c_p = \frac{1}{2} \{ c_g + (1 + \eta) \frac{P_e}{A} \} - \sqrt{ \left\{ \frac{1}{2} c_g + \frac{1}{2} (1 + \eta) \frac{P_e}{A} \right\}^2 - c_g \frac{P_e}{A} }$$

$$\text{or } K_{18} = \frac{c_p}{c_g} = \frac{1}{2} + \frac{1}{2} (1 + \eta) \frac{P_e}{c_g A} - \sqrt{ \left\{ \frac{1}{2} + \frac{1}{2} (1 + \eta) \frac{P_e}{c_g A} \right\}^2 - \frac{P_e}{c_g A} } \quad \text{--- (7)}$$

---

\*"A mathematical basis for design aids for timber columns", paper for CIB W18 meeting, Aalborg, Denmark, June 1970.

A later section of the previous paper (page 5, equation (6) ) gave the following equation similar to (6) above but allowing for a uniform lateral load  $w$ :

$$c_g = c_a \left( 1 + \frac{\eta c_a}{1 - \frac{c_a}{f_c}} \right) + \frac{3}{4} \frac{w l^2}{d^2} \lambda(u) \quad (8)$$

This expression, restricted to rectangular members in the form shown, is a result of the theory of elastic stability and limits the stress on the concave face to  $c_g$ . If it is desired to vary the maximum stress from  $f_p$  to  $c_g$  as  $c_a$  ranges from 0 to  $c_f$ , this can be done by changing (8) to the "combined stress" form,

$$1 = \frac{c_a}{c_g} \left\{ 1 + \frac{\eta}{1 - \frac{c_a}{f_c}} \right\} + \frac{3}{4} \frac{w l^2}{d^2} \frac{\lambda(u)}{f_p} \quad (9)$$

which reduces to (6) when the lateral load  $w = 0$ .

The previous paper went on to say that Larsen's method applies a "combined stress" equation even to a column without lateral load, so that with  $w=0$  the constituent  $\frac{c_a \eta}{1 - \frac{c_a}{f_c}}$  of equation (8), arising from the bending moment caused by the longitudinal load, is divided by  $f_p$  instead of  $c_g$ . This procedure is in conflict with the traditional UK method where solving (6) to obtain the Perry formula implies that both the constituents  $c_a$  and  $\frac{c_a \eta}{1 - \frac{c_a}{f_c}}$  are divided by  $c_g$ .

Using the approximation

$$\lambda(u) = \frac{1}{1 - \frac{c_a}{f_c}}$$

a solution  $c_a$  of (6) was given which agreed with the Perry formula, and then the alternative solution following Larsen's method was shown as

$$c_a = \frac{1}{2} \left\{ c_g + \left( 1 + \frac{c_g}{f_p} \eta \right) f_c \right\} - \sqrt{\left\{ \frac{1}{2} c_g + \frac{1}{2} \left( 1 + \frac{c_g}{f_p} \eta \right) f_c \right\}^2 - \left\{ 1 - \frac{f_c}{f_p} \right\} c_g f_c}$$

If  $f_c = 0$  this reduces to

$$\frac{c_a}{c_g} = \frac{1}{2} + \frac{1}{2} \left( 1 + \frac{c_g}{f_p} \eta \right) \frac{f_c}{c_g} - \sqrt{\left\{ \frac{1}{2} + \frac{1}{2} \left( 1 + \frac{c_g}{f_p} \eta \right) \frac{f_c}{c_g} \right\}^2 - \frac{f_c}{c_g}} \quad (10)$$

Equation (10) may be derived directly from (6) by changing it to the combined stress form agreeing with the Larsen's method:

$$1 = \frac{C_a}{C_g} + \frac{C_a \eta}{f_r (1 - \frac{C_a}{C_p})}$$

and solving for  $C_a$  to give

$$C_a = \frac{1}{2} \left\{ C_g + \left( 1 + \frac{C_g \eta}{f_r} \right) p_e \right\} - \sqrt{\left[ \frac{C_g + \left( 1 + \frac{C_g \eta}{f_r} \right) p_e}{2} \right]^2 - C_g p_e}$$

which is the same as (10).

Equation (10) can appropriately be called a modified Perry formula since the essence of Perry's method was to represent the effect of end eccentricity by an additional curvature as described below, and not to limit the maximum stress to  $C_g$  for timber.

#### REDUCTION OF LARSEN FORMULA TO MODIFIED PERRY FORM

In Larsen's equation, formula (4) above, if the substitutions  $\alpha = 0$ ,  $\psi = 1$ ,  $\epsilon = b\lambda$  are made corresponding to a zero end eccentricity of the load, the result is

$$\frac{\Delta \sigma}{\Delta \epsilon} = \frac{1}{2} + \frac{1}{2} \left( 1 + \frac{\Delta \epsilon}{\Delta b} b \lambda \right) \frac{p_e}{C_g} - \sqrt{\left\{ \frac{1}{2} + \frac{1}{2} \left( 1 + \frac{\Delta \epsilon}{\Delta b} b \lambda \right) \frac{p_e}{C_g} \right\}^2 - \frac{p_e}{C_g}} \quad (11)$$

- where  $k_E$  has been replaced by  $\frac{p_e}{C_g}$  since  $\Delta \epsilon$  has the value  $C_g$  when  $\alpha = 0$ ; similarly  $\frac{\Delta \sigma}{\Delta \epsilon}$  may be replaced by  $\frac{C_g}{C_g}$  so the equation is identical to (10).

The same can be seen much more easily from (5), the modified form of Larsen's result. This represents  $\frac{C_p}{C_g}$  when  $\alpha = 0$  and is the same as (10) except that  $\eta$  appears instead of  $\epsilon$ ; the two symbols have the same meaning when  $\alpha = 0$  in Larsen's formula.

#### TREATMENT OF END ECCENTRICITY IN THE TWO METHODS

The above reduction of Larsen's formula to the modified Perry form when  $\alpha = 0$  is a useful algebraic check, but the agreement between the two is actually much more far-reaching since equations (5) and (10) show the methods are also identical when  $\alpha$  is not zero, except for the values given to  $\epsilon$  and  $\eta$ .

Perry method

The 1886 article by Ayrton and Perry points out that the function  $\sec\left(\frac{\pi}{2} \sqrt{\frac{\sigma_c}{\sigma_E}}\right)$  in Larsen's equation (5) for  $e_2 = 0$  corresponds very closely with  $\frac{1.2}{1 - \frac{c_{25}}{R_e}}$ , i.e. 1.2 times the factor by which  $e_2$  is amplified in Larsen's equation (4) for  $e_1 = 0$ . In other words if the maximum deviation from straightness is taken as

$$e = 1.2e_1 + e_2$$

a column initially curved and eccentrically loaded at its ends may be taken as centrally loaded at its ends with the augmented initial curvature.

The value of  $\eta$  in (10) may therefore be found from just above equation (6) as

$$\frac{a h}{r^2} = \frac{1}{R} (1.2e_1 + e_2) = 1.2\epsilon_1 + \epsilon_2$$

(The symbol  $\alpha$  used here is not the same as Larsen's).

Larsen method

As seen in the derivation above, Larsen takes the total initial eccentricity as  $e = e_1 + e_2$

so in equation (5) the value of  $\epsilon$  is

$$\epsilon = \frac{e_1}{R} + \frac{e_2}{R} = \epsilon_1 + \epsilon_2$$

Reconciliation of the two methods

As seen in equations (5) and (9) there is no difference between the Larsen and the modified Perry method except for the differences in  $\epsilon$  just stated. It may be of interest to show the figures presented by Ayrton and Perry, although after 90 years there is unlikely to be any change in opinion over the "1.2" value they selected:

$\frac{P}{P_e}$	$\frac{1}{1 - \frac{P}{P_c}}$	$\sec \left( \frac{\pi}{2} \sqrt{\frac{P}{P_e}} \right)$
0	1	1
.1	1.11	1.14
.2	1.25	1.31
.3	1.43	1.53
.4	1.67	1.83
.5	2.00	2.25
.6	2.50	2.88
.7	3.33	3.94
.8	5.00	6.06
.9	10.00	12.42
1.0	$\infty$	$\infty$

It should obviously be recommended that other countries adopt the same basis as the U.K., namely  $\epsilon = \epsilon_1 + \epsilon_2$ . Even if they do not, it will be possible to assume that they have done so but with a different allowance for end eccentricity. For example a country might adopt

$$\epsilon_1 + \epsilon_2 = 0.10 + 0.005 \lambda$$

which could be interpreted as  $1.2 \epsilon_1 + \epsilon_2 = 1.2 \times 0.083 + 0.005 \lambda$  for the Perry type of derivation.

A value such as  $\epsilon = 0.005 \lambda$  in a U.K. calculation does of course imply that both the end eccentricity and the initial deviation from straightness are proportional to  $\lambda$ , without showing a share apportioned to each. The practice in design is to treat the load as "nominally axial" and cater for accidental eccentricity as provided by the Perry method, which however would be equally applicable to the form  $a + b \lambda$ ; a very good reason for not doing this is the extra complication in design aids.

RECONCILIATION OF PERRY AND LARSEN FORMULAE

Although the remainder of this paper is a parochial discussion of U.K. problems, it is included because similar considerations may be valid in other countries.

The equation used in the United Kingdom is (7) and not (10). When equation (4) is presented for adoption in place of (7), reluctance arises because it is apparently much more complicated. Additional parameters are introduced and  $\beta = \frac{c_0}{f_r}$  is not a simple ratio of timber properties but includes the value  $c_0 = \frac{c_1 f_r}{f_r + a c_2}$ . If the formula were written out in full it would appear immensely complicated compared with (7).

When (4) is changed to the form (5), however, the likelihood of its acceptance in the U.K. seems much greater because of its close similarity to (7). The extra parameter  $\frac{c_1}{f_r}$  presents a serious disadvantage by adding a dimension to any design aid for universal application to a range of timbers, although not causing extra complication in a design aid for a single timber grade.

As the additional parameter has a logical basis and provides a treatment consistent with the 'combined stress' approach adopted when the column carries lateral load, it does have great attractions even if it is found that the results produced by equations (5) and (7) do not differ very greatly.

The most important factor is the discovery from comparing equations (5) and (10) that Larsen's formula can be developed in a way agreeing precisely with the long-standing Perry approximation. The form in which it was presented (4) gave the opposite impression, especially when accompanied by the suggestion that some countries assume  $a = 0$  (no end eccentricity) when this is not necessarily the case; the same suggestion might arise from comparing equation (5) with (4).

INTERNATIONAL COUNCIL FOR BUILDING RESEARCH STUDIES AND DOCUMENTATION  
WORKING COMMISSION W18 - TIMBER STRUCTURES

THE DETERMINATION OF THE MECHANICAL PROPERTIES OF PLYWOOD  
CONTAINING DEFECTS

by

L G BOOTH  
Department of Civil Engineering  
Imperial College  
London  
United Kingdom

The determination of the mechanical properties of plywood containing defects.

L G Booth

Department of Civil Engineering

Imperial College, London

### Introduction

At recent meetings of CIB Working Group W18 the problems of determining the mechanical properties of plywood containing defects have been discussed in some detail. Following the preparation by Jan Kuipers of a summary paper (Delft meeting, March 1974) on the tests used in different countries, he was asked to hold further discussions with Carl Wilson with a view to preparing a draft standard for submission to this Group. Unfortunately Wilson was not able to attend the next meeting (Paris, February 1975), but he sent a written submission explaining in more detail the methods used by COFI in Canada. At the next meeting (Karlsruhe, October 1975) further discussion of the problem took place and it was agreed that sufficient progress had been made for a draft document to be prepared.

Whilst the discussions were taking place within W18, work was in hand in the UK on the revision of CP 112: The Structural use of timber. It became clear that a number of test standards were required, and that these needed to be

published at the same time as (or before) the revision of CP 112: one of the standards required was methods of testing of plywood containing defects. In the past, Codes and Standards have been prepared on a collaborative basis by several interested organisations and individuals, but it has been found that this procedure can take several years to prepare even a draft document. Recently the Department of the Environment, acting in collaboration with the BSI, has initiated a new policy of placing contracts with organisations or individuals to prepare complete draft Codes or Standards and only when this has been done will a committee be formed. The attached standard has been prepared under this procedure with the Princes Risborough Laboratory of the Building Research Establishment acting as the supervising body and with the detailed preparation being undertaken by me.

During the preparation of the draft I have borne in mind the discussions within W18. I have found Kuipers' original paper invaluable: the numerous reports prepared by COFI during their extensive test programme on Douglas fir plywood (the testing philosophy was aptly summarised by Wilson for the Paris meeting) have represented the largest body of data I have consulted: I have also had the benefit of reading several letters by Bengt Noren to Kuipers and Wilson, together with some personal discussions with him. I am very grateful for their help in particular, and W18 in general.

Having acknowledged my debt, I must however emphasize that the form of the Standard and the choice of specimens is mine

alone and no one else can be criticised for any mistakes or injudicious choices. Although the document has been prepared as a draft British Standard, hopefully it can also form the basis of an international standard under the aegis of RILEM or ISO. The format follows the existing BSI pattern, but this is not sacrosanct and it can easily be changed (hopefully for good reasons). My main aim, and BSI's, is to prepare a document that will have international agreement, and in this context it is with the full approval of BSI and DOE that this draft is being considered by W18 before its official submission to BSI.

One final point concerning my contract with DOE is that it called for a draft standard and also a background report. This background report, which is a lengthy document with several appendices, contains details of existing standards, comparative test data with different specimens and the reasons for the choice of specimens in the proposed draft: because of the size of the report it is unlikely to be available for general circulation, but a summary may be prepared.

It was mentioned above that the format of the draft followed current BSI procedure, and in particular it is based on the current standard for testing small clear specimens of plywood (BS 4512). There are some alternative editorial forms and the Group may wish to consider the following.

1. The ASTM publishes separate standards for each test (eg bending, rolling shear, etc) and these standards usually contain varying amounts of explanatory matter,

whereas I have prepared one standard and have given virtually no explanatory matter.

2. I have tried to make the standard as short as possible and have assumed that it will be used by test workers with some experience whereas current ISO drafts (eg ISO DIS 4843: Plywood - determination of modulus of elasticity in tension and of tensile strength) seems to adopt the other extreme.
3. The method of determining the modulus of elasticity from load-deformation data is treated differently. The BS (and this draft) gives incremental loads in a formula, ASTM uses the slope of the curve in a formula, and ISO specifies the calculation by plotting a graph.

A principle that must be decided is whether the standard should give alternative test methods for some properties (eg bending, panel shear). The procedure adopted in the draft is to give alternative methods but to describe one as the preferred method. In the short term we may have to accept alternative methods, but in the long term I think we should aim to eliminate them from the standard. If we do give alternatives, and for a first standard this is probably necessary, then should we state that they will be phased out by a specified date?

A further matter of principle to be agreed is whether an additional standard is required on sampling from the mill and from the panel. Should the specimens be cut from the panel according to some predetermined cutting schedule (eg NEN 3519)?

This procedure has not been used in this draft since it adopts the philosophy of specifying that the specimens shall be cut from the panel in such a way that they contain the maximum face defect permitted by the grade. Random selection will give the strength of material within the particular grade, whereas the procedure adopted in the draft aims to give the strength of material at the lower bound of the grade. This choice must to some extent be linked with the procedure to be subsequently adopted to determine characteristic and design stresses.

The above matters of principle should be discussed before considering the actual specimen geometries adopted in the draft.

In choosing the specimen type and size, I have been influenced by the plywoods that are used in the UK and that are likely to be tested in accordance with the standard. The plywoods range from large to small defect material, from softwoods to hardwoods and combinations thereof: as such they probably represent the range of the world's products and consequently the standard should be suitable for international use. For specific countries that manufacture a uniform product with small defects, the specimens chosen may be larger than necessary and existing small clear standards may be adequate.

The background study indicated that relatively little information exists on the effect of size on specimen strength: the comparative data is usually within a species and never(?) covers several species. COFI have issued several reports

that formed phase 1 of their test programme on softwood (Douglas fir) plywood, but the primary purpose of this work was to determine an "adequate" specimen size rather than to find the effect of size. These, and some American Plywood Association reports, influenced my choice, but the choice has still to be based on engineering judgement rather than comprehensive evidence. I have recently been told that birch plywood, some of which may be argued to be uniform with small defects, has been tested in bending in different sizes, but the results do not appear to be available (at least not in English). In the absence of conclusive evidence I have adopted what I think is a reasonable compromise. Whereas ASTM and COFI specimens could be described as "large", and the BSI clear specimens as "small", the specimens adopted in this standard tend to be "medium" size: this is particularly so in the case of bending.

Apart from the choice of size of a specimen, there is the prior choice of the type of specimen to be used. Here one must try to establish a different set of principles. The test specimen should be as small as possible commensurate with defects within the grade: the specimen should be easy to manufacture and test: the stress distribution should be uniform and free from concentrations: members attached to the specimen for the purpose of loading should not strengthen the specimen by restricting the mode of failure: the stress distribution within the specimen should be known. All these ideal attributes can very rarely be found in one specimen and the choice is inevitably a compromise.

Finally, we must remember that when we have agreed a standard and when plywoods have been tested in accordance with it, a further set of different problems remains to be resolved. If specimen strength is size dependent (and it definitely is), we require a series of factors that will modify the test specimen strength into a strength applicable to component design. In some respects this is an even more difficult problem, but hopefully we can call on the structural engineer to share some of our future burden.

Draft British Standard

Methods of test for the determination of mechanical  
properties of plywood containing defects

Foreword

(to be prepared when standard is agreed)

Methods of test

1 Scope

This British Standard covers procedures for measuring the mechanical properties of commercial plywood containing defects permitted by the manufacturing specification. The tests described may be used to obtain data for design purposes, to determine the effect on strength of various natural and manufacturing defects, to ascertain properties in relation to grain or fibre direction in the material, to compare the properties of different species and for other similar purposes.

Methods are described for determining the following properties:

bending: preferred method of test (clause 4), bending: alternative method of test (clause 5), compression (clause 6), tension (clause 7), panel shear: preferred method of test (clause 8), panel shear: alternative

method of test (clause 9), modulus of rigidity (clause 10), rolling shear (clause 11), moisture content (clause 12) and density (clause 13).

Any of these tests, or part of them, may be undertaken.

Tests of the glue in plywood are not included as they are covered in BS 1203: Synthetic resin adhesives (phenolic and aminoplastic) for plywood.

Tests on clear plywood, defined as that manufactured from veneers containing no strength reducing defects and with no manufacturing features that will influence strength (eg core gaps), may be tested in accordance with this Standard but in general it will be more economical to test it in accordance with BS 4512: Methods of test for clear plywood.

## 2 Test specimens

### 2.1 Sampling procedures for panels and test specimens

The test specimens and the panels from which they are cut shall be sampled in accordance with BS 0000.

To determine the average and characteristic strength and stiffness values for a particular species or type of construction, not less than 30 acceptable tests to measure each property shall be made.

### 2.2 Orientation of the grain

Specimens for test may be selected either with the long dimension parallel to the face grain or with the long

dimension perpendicular to the face grain, or the grain may be orientated to the long dimension at any other angle for which data is required.

### 2.3 Location of defects

The specimens shall be cut from the panel so that the worst defects permitted by the grade occur in the specimen. The location of the worst defect within the specimen shall be as stated in the clauses dealing with the relevant tests.

The size of the specimens and the purpose of the tests precludes the standardisation of a cutting schedule based on the position of the specimens within the panel. Specimens shall in no case be taken from less than 50 mm from the edges of the panel.

### 3 Moisture content and temperature

The values of the mechanical properties of plywood depend upon the moisture content of the material at the time of testing. All specimens shall normally be conditioned, prior to final machining and testing, to constant mass and moisture content in a conditioning chamber maintained at a relative humidity of  $65 \pm 2$  per cent and at a temperature of  $20 \pm 3^{\circ}\text{C}$ . Constant mass is considered to be reached when two successive weighing operations, carried out at an interval of 24 hours, do not differ by more than 0.1 per cent of the mass of the test piece.

Where possible, conditions of testing should be the same as those in the conditioning chamber, but where this is not possible tests should be undertaken immediately after the specimens have been removed from the conditioning chamber.

Where it is not acceptable to adjust the strength values to other temperature and humidity conditions the tests may be carried out at other temperature and humidity conditions.

#### 4 Bending: **preferred method of test**

##### 4.1 Test specimen

##### 4.1.1 Measurements

The method of taking measurements and the type of equipment to be used shall be in accordance with ISO/DIS 3804: Plywood- Determination of dimensions of test pieces.

The specimen thickness shall be measured to the nearest 0.02 mm at four points, two on each edge 300 mm from each end, and the average recorded. The specimen width shall be measured to the nearest 1 mm at two points 300 mm from each end, and the average recorded.

When needed for the interpretation of test results, the thickness of each ply shall be measured to the nearest 0.02 mm at the same points at which the specimen thickness is measured.

##### 4.1.2 Size of specimen

The test specimen shall be rectangular in cross-section. The depth of the specimen shall be equal to the thickness of the plywood and the width shall be 300 mm. The length of the specimen will depend on the actual method of applying the load (see clause 4.2) but shall be sufficient to ensure that the length of the zone subjected to the uniform moment shall be not less than 600 mm.

##### 4.1.3 Sampling of test specimens from a panel

The size of the specimens and the purpose of the tests precludes the standardisation of a cutting schedule based on the position of the specimens within the panel.

Since the purpose of the tests is to determine the weakest

cross-section of width 300 mm, the specimens shall be cut from the panel so that the worst defects permitted by the grade occur in the specimen. For high grade plywoods it may be possible to cut only one or two specimens from a 2400 mm x 1200 mm panel: for low grade plywoods it may be possible to cut about 5 specimens from a panel.

An estimate shall be made of the worst face of the specimen and this face shall be stressed in tension during the bending test. When core gaps are present in the specimen they shall be stressed in tension during the bending test.

#### 4.2 Loading method and equipment

The load shall be applied as equal and opposite pure moments to the ends of the specimen. The method of applying the load shall be such that direct tension or compression forces are not applied to the specimen at large deformations.

The moment applied at either or both ends of the specimen shall be recorded either directly or in terms of a parameter related to the moment.

#### 4.3 Test procedure

##### 4.3.1 Rate of application of load

The load shall be applied with a continuous motion throughout the test. The rate of load application shall be such that the unit rate of fibre strain is equal to 0.000 05 mm per mm of outer fibre length per

second, within a permissible variation of  $\pm 25$  per cent.

The time taken from the beginning of the loading to the maximum load shall be measured and recorded to the nearest 30 seconds.

#### 4.3.2 Measurement of panel curvature

The curvature of the specimen shall be measured between two points on the longitudinal axis of the specimen located in the zone of uniform moment and spaced as far apart as possible consistent with maintaining adequate clearance between the gauges and the loading frame. The curvature data shall be measured to an accuracy of not less than  $1\frac{1}{2}$  per cent of the proportional limit values. If dial gauges are used to read the deflection, increments of load shall be chosen so that not less than 12 and preferably 15 or more readings of load and deflection are taken. Automatic load and deflection recording apparatus may be used provided the curves obtained are of sufficient magnitude to allow accurate measurement of load and deflection.

The curvature data may be obtained from either the mid-ordinate deflection method or the angular rotation method. The mid-ordinate method uses readily available equipment and is satisfactory for most test programmes. The angular rotation method requires special instruments which are not usually available: details are however given in Appendix 1.

An apparatus suitable for measuring the specimen

curvature is shown in figure 1. The deflection may be measured by a dial gauge which shall be read to the nearest 0.02 mm. Automatic recording apparatus may be used if it can achieve comparable accuracy.

#### 4.4 Calculations

##### 4.4.1 Bending stiffness

The specimen bending stiffness shall be calculated from

$$EI = \frac{\Delta M}{\Delta K}$$

where EI = bending stiffness for a 300 mm wide specimen, N.mm<sup>2</sup>

$\Delta M$  = increment of moment on the straight line portion of the moment-curvature curve, N.mm

$\Delta K$  = increment of curvature corresponding to  $\Delta M$ , mm<sup>-1</sup>.

If the curvature is obtained from the mid-ordinate method

$$\frac{1}{K} = \frac{L^2}{8\delta} + \frac{\delta}{2}$$

where K = curvature, mm<sup>-1</sup>

L = chord length for measuring mid-ordinate or deflection, mm

$\delta$  = mid-ordinate or deflection, mm

The bending stiffness shall also be stated for a panel of width 1 m by multiplying the specimen stiffness by the factor 10/3.

If the bending modulus of elasticity (E) is subsequently calculated from the bending stiffness, the method of specifying the second moment of area (I) must be stated.

#### 4.4.2 Moment of resistance

The ultimate moment of resistance of the specimen of width 300 mm is the maximum end moment resisted by the specimen.

The ultimate moment of resistance shall also be stated for a panel of width 1 m by multiplying the specimen ultimate moment of resistance by the factor 10/3.

#### 4.4.3 Modulus of rupture

The modulus of rupture shall be calculated from

$$\sigma = \frac{M}{W}$$

where  $\sigma$  = modulus of rupture, N/mm<sup>2</sup>

$M$  = maximum moment, N.m

$W$  = section modulus, mm<sup>3</sup>

The method of specifying the section modulus shall be stated.

#### 4.5 Moisture content and density

After each test, samples which are to be used to measure the moisture content and density shall be cut from the specimen. The samples shall have a minimum volume of 50 000 mm<sup>3</sup> and shall be free of visible knots, knot holes, core gaps and other voids in any ply.

The moisture content and density of each test specimen shall be determined in accordance with clauses 12 and 13.

## 5 Bending : alternative method of test

### 5.1 Test specimen

#### 5.1.1 Measurements

The method of taking measurements and the type of equipment to be used shall be in accordance with ISO/DIS 3804: Plywood - Determination of dimensions of test pieces.

The specimen thickness shall be measured to the nearest 0.02 mm at four points, two on each edge 100 mm from each end, and the average recorded. The specimen width shall be measured to the nearest 1 mm at two points 100 mm from each end, and the average recorded.

When needed for the interpretation of test results, the thickness of each ply shall be measured to the nearest 0.02 mm at the same points at which the specimen thickness is measured.

#### 5.1.2 Size of specimen

The test specimen shall be rectangular in cross-section. The depth of the specimen shall be equal to the thickness of the plywood and the width shall be 300 mm.

The length of the plywood specimens shall be not less than the greater of 500 mm and  $48t + 50$  mm where

$t$  = thickness of the plywood when the grain direction of the face plies is parallel to the span and

$t$  = thickness of the plywood minus the thickness of the face plies when the grain direction of the face plies is perpendicular to the span.

### 5.1.3 Sampling of test specimens from a panel

The size of the specimens and the purpose of the tests precludes the standardisation of a cutting schedule based on the position of the specimens within the panel.

Since the purpose of the tests is to determine the weakest cross-section of width 300 mm, the specimens shall be cut from the panel so that the worst defects permitted by the grade occur in the middle third of the specimen length.

For high grade plywoods it may be possible to cut only one or two specimens from a 2400 mm x 1200 mm panel: for low grade plywoods it may be possible to cut about 5 specimens from a panel.

An estimate shall be made of the worst face of the specimen and this face shall be stressed in tension during the bending test. When core gaps are present in the specimen they shall be stressed in tension during the bending test.

### 5.2 Loading method and equipment

The load shall be applied at the third points of the span.

The span shall be not less than the greater of 450 mm and  $48t$  where

$t$  = thickness of the plywood when the grain direction of the face plies is parallel to the span and

$t$  = thickness of the plywood minus the thickness of the face plies when the grain direction of the face plies is perpendicular to the span.

A 25 mm overhang shall be allowed at each end. The span shall be estimated as an average of the material and need not be altered for slight variations in the thickness of individual specimens. The specimens shall be flat, and any showing excessive twist shall be rejected. Round nosed knife edges or roller bearings preferably allowing for longitudinal movement may be used; the radius of curvature of the loading block shall be 13 mm. In cases where excessive local deformation may occur under the loading points, suitable bearing plates shall be used. An apparatus suitable for making bending tests is shown in figure 2.

### 5.3 Test procedure

#### 5.3.1 Rate of application of the load

The load shall be applied with a continuous motion of the movable head throughout the test. The rate of load application shall be such that the unit rate of fibre strain is equal to 0.000 05 mm per mm of outer fibre length per second, within a permissible variation of  $\pm 25$  per cent. The rate of motion of the movable head may be calculated as follows:

$$R = \frac{ra (3L - 4a)}{3h}$$

where R = rate of motion of moving head, mm/s;  
 a = distance from reaction to nearest load point, mm;  
 L = span, mm;  
 h = depth of beam, mm;  
 r = unit rate of fibre strain, millimetres per millimetre of outer fibre length per second  
 (= 0.000 05)

The time taken from the beginning of the loading to the maximum load shall be measured and recorded to the nearest **30 seconds**.

### 5.3.2 Measurement of deflection

Data for load-deflection curves may be taken to determine the modulus of elasticity in bending. Deflections shall be recorded at each load point and at mid-span: they may be recorded using dial gauges as in figure 2.

The readings shall be taken to the nearest 0.02 mm.

Increments of load shall be chosen so that not less than 12 and preferably 15 or more readings of load and deflection are taken. Automatic load and deflection recording apparatus may be used provided the curves obtained are of sufficient magnitude to allow accurate measurement of load and deflection.

## 5.4 Calculations

### 5.4.1 Bending stiffness

The specimen bending stiffness shall be calculated from

$$EI = \frac{\Delta PL^3}{432 \Delta \delta}$$

where EI = bending stiffness for a 300 mm wide specimen,  
N,mm<sup>2</sup>

$\Delta P$  = increment of load on the straight line portion  
of the load-deflection curve, N

$\Delta \delta$  = increment of mid-span deflection relative to  
the points of application of the loads, mm

L = span, mm

The bending stiffness shall also be stated for a panel of width 1m by multiplying the specimen stiffness by the factor 10/3.

If the bending modulus of elasticity (E) is subsequently calculated from the bending stiffness, the method of specifying the second moment of area (I) must be stated.

#### 5.4.2 Moment of resistance

The ultimate moment of resistance of the specimen of width 300 mm shall be calculated from

$$M = \frac{PL}{6}$$

where M = ultimate moment of resistance of 300 mm wide specimen, N.mm

P = ultimate load, N

L = span, mm

The ultimate moment of resistance shall also be stated for a panel of width 1 m by multiplying the specimen ultimate moment of resistance by the factor 10/3.

#### 5.4.3 Modulus of rupture

The modulus of rupture shall be calculated from

$$\sigma = \frac{M}{W}$$

where  $\sigma$  = modulus of rupture, N/mm<sup>2</sup>

M = ultimate moment, N.mm

W = section modulus, mm<sup>3</sup>

The method of specifying the section modulus shall be stated.

### 5.5 Moisture content and density

After each test, samples which are to be used to measure the moisture content and density shall be cut from the specimen. The samples shall have a minimum volume of 50 000 mm<sup>3</sup> and shall be free of visible knots, knot holes, core gaps and other voids in any ply.

The moisture content and density of each test specimen shall be determined in accordance with clauses 12 and 13.

## 6 Compression

### 6.1 Test specimen

#### 6.1.1 Measurements

The method of taking measurements and the type of equipment to be used shall be in accordance with ISO/DIS. 3804: Plywood - Determination of dimensions of test pieces.

The specimen thickness shall be measured to the nearest 0.02 mm at four points, two on each edge 100 mm from each end, and the average recorded. The specimen width shall be measured to the nearest 1 mm at two points 100 mm from each end, and the average recorded.

When needed for the interpretation of test results, the thickness of each ply shall be measured to the nearest 0.02 mm at the same points at which the specimen thickness is measured.

#### 6.1.2 Size of specimen

The test specimen shall be rectangular in cross-section. Care shall be taken in preparing the test specimens to make the end surfaces smooth and parallel to each other and at right angles to the length.

The width of the specimen shall be 200 mm and its length shall be 400 mm.

In order to eliminate buckling several pieces of the plywood to be tested shall be glued face to back until

the thickness of the test specimen is not less than 40 mm. If data is only required up to the proportional limit, the thickness of the test specimen shall be not less than 20 mm.

### 6.1.3 Sampling of test specimens from a panel

The specimens shall be cut from the panel so that the worst defects permitted by the grade occur in the specimen.

When several pieces of plywood are glued together to form the test specimen each piece shall contain the worst defects permitted by the grade.

Four test specimens, of which two shall have the grain direction of the face plies parallel to the length and two perpendicular to the length, shall be cut from each panel.

## 6.2 Loading method and equipment

The load shall be applied through a hinged connection on the upper head of the testing machine to allow for any deviation from parallel of the ends of the specimen, and permit adjustment to the end of the specimen in one direction. The specimen shall be loosely held by the side restraining rail. An apparatus suitable for making compression tests is shown in figure 3.

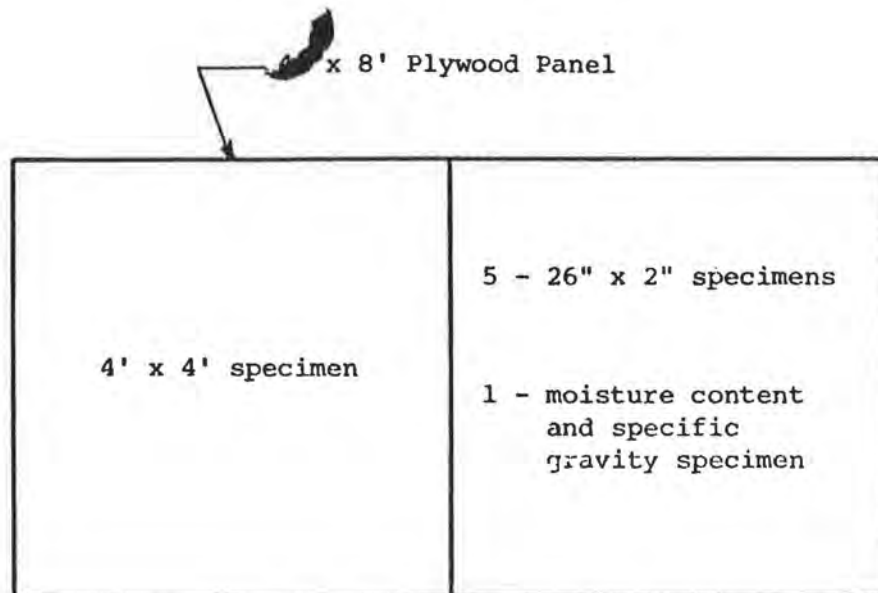

FIGURE 1. CUTTING PLAN

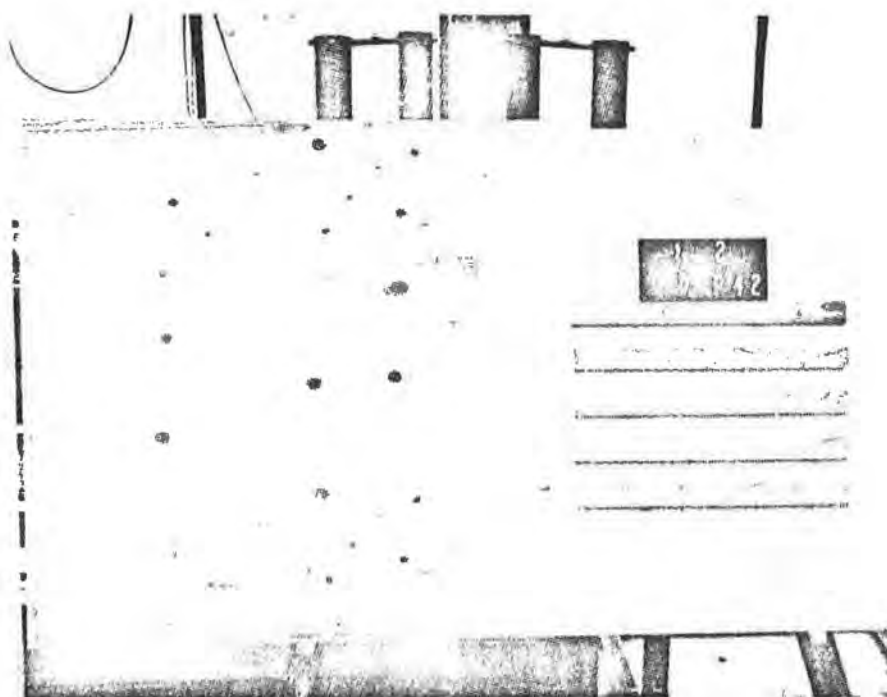

PLATE 1. TYPICAL SPECIMENS FROM A PLYWOOD PANEL

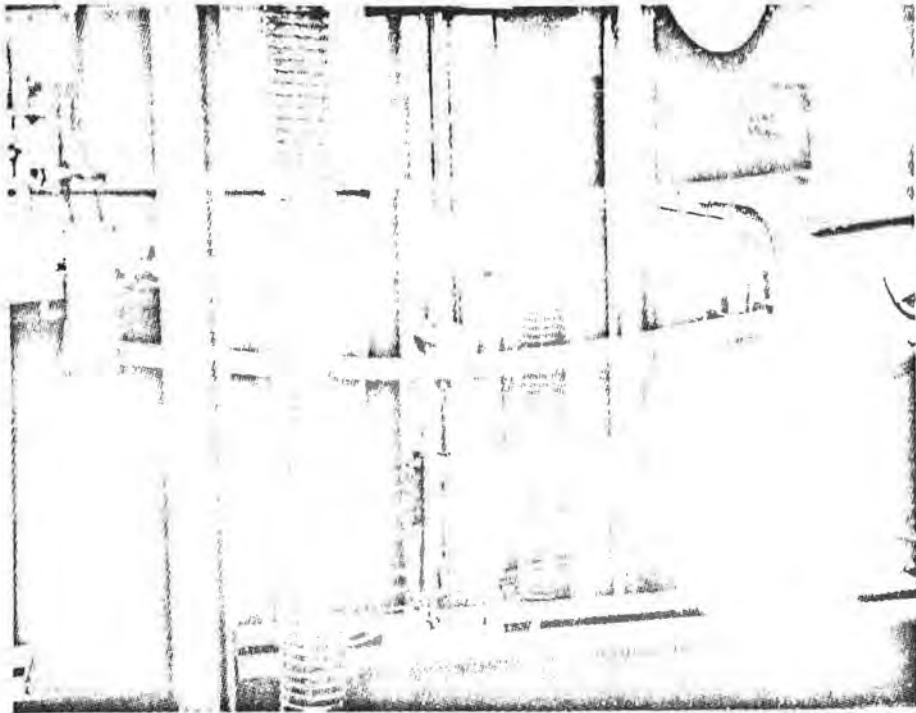

PLATE 2. ASTM METHOD A FLEXURE TEST



PLATE 3. ASTM METHOD C FLEXURE TEST

TABLE 1FLEXURAL PROPERTIES AS DETERMINED BY FULL CROSS SECTION THEORY

Plywood: 1/2 inch - 5 ply Sheathing Grade DFP Manufactured to CSA Standard O121-1973

Test Procedures: ASTM D 3043-72, Method A (small clear) and Method C (in-grade)

Panels Tested: 40

Specimen Sizes: 5 - 2" x 26" (span 24") small clear specimens and 1 - 4' x 4' in-grade specimen from each panel

Face Grain to Span Orientation: 0°

PROPERTY		SPECIMEN TYPE	
FLEXURAL	STATISTICAL	SMALL CLEAR	IN-GRADE
MODULUS OF RUPTURE	Mean (psi)	9177	5801
	Standard Deviation (psi)	1752	958
	Coefficient of Variation (%)	19.1	16.5
	5% Exclusion Value (psi)	6295	4225
MODULUS OF ELASTICITY	Mean ( $10^6$ psi)	1.614	1.757
	Standard Deviation ( $10^6$ psi)	0.177	0.182
	Coefficient of Variation (%)	10.9	10.4
	5% Exclusion Value ( $10^6$ psi)	1.323	1.458

TABLE 2FLEXURAL PROPERTIES AS DETERMINED BY PARALLEL PLY THEORY\*

Plywood: 1/2 inch - 5 ply Sheathing Grade DFP Manufactured to CSA Standard O121-1973

Test Procedures: ASTM D 3043-72, Method A (small clear) and Method C (in-grade)

Panels Tested: 40

Specimen Sizes: 5 - 2" x 26" (span 24") small clear specimens and 1 - 4' x 4' in-grade specimen from each panel

Face Grain to Span Orientation: 0°

PROPERTY		SPECIMEN TYPE	
FLEXURAL	STATISTICAL	SMALL CLEAR	IN-GRADE
MODULUS OF RUPTURE	Mean (psi)	11732	7452
	Standard Deviation (psi)	2167	1259
	Coefficient of Variation (%)	18.5	16.9
	5% Exclusion Value (psi)	8167	5381
MODULUS OF ELASTICITY	Mean (10 <sup>6</sup> psi)	2.055	2.257
	Standard Deviation (10 <sup>6</sup> psi)	0.238	0.254
	Coefficient of Variation (%)	11.6	11.3
	5% Exclusion Value (10 <sup>6</sup> psi)	1.663	1.839

\* "Parallel Ply Theory" neglects contribution of perpendicular plies in calculating section properties.

TABLE 3

FLEXURAL PROPERTIES AS DETERMINED BY EXACT THEORY\*

**Plywood:** 1/2 inch - 5 ply Sheathing Grade DFP Manufactured to CSA Standard O121-1973

**Test Procedures:** ASTM D 3043-72, Method A (small clear) and Method C (in-grade)

**Panels Tested:** 40

**Specimen Sizes:** 5 - 2" x 26" (span 24") small clear specimens and 1 - 4' x 4' in-grade specimen from each panel

**Face Grain to Span Orientation:** 0°

PROPERTY		SPECIMEN TYPE	
FLEXURAL	STATISTICAL	SMALL CLEAR	IN-GRADE
MODULUS OF RUPTURE	Mean (psi)	11580	7348
	Standard Deviation (psi)	2147	1240
	Coefficient of Variation (%)	18.5	16.9
	5% Exclusion Value (psi)	8048	5307
MODULUS OF ELASTICITY	Mean (10 <sup>6</sup> psi)	2.003	2.225
	Standard Deviation (10 <sup>6</sup> psi)	0.236	0.248
	Coefficient of Variation (%)	11.6	11.1
	5% Exclusion Value (10 <sup>6</sup> psi)	1.645	1.817

\* "Exact Theory" assumes a 5% contribution of perpendicular plies in calculating section properties.

TABLE 4

EFFECT OF TYPE AND SIZE OF SPECIMEN AND TYPE OF TEST  
ON FLEXURAL PROPERTIES\*

PROPERTY		RATIO OF SMALL CLEAR/IN-GRADE
FLEXURAL	STATISTICAL	
MODULUS OF RUPTURE	Mean	1.58
	5% Exclusion Value	1.52
MODULUS OF ELASTICITY	Mean	0.90
	5% Exclusion Value	0.91

\* The properties compared are those listed in Table 3, "Flexural Properties as Determined by Exact Theory"

A comparison of properties using the full cross section theory and the parallel ply theory would result in very similar ratios.

INTERNATIONAL COUNCIL FOR BUILDING RESEARCH STUDIES AND DOCUMENTATION  
WORKING COMMISSION W18 - TIMBER STRUCTURES

BUCKLING STRENGTH OF PLYWOOD  
RESULTS OF TESTS AND RECOMMENDATIONS FOR CALCULATIONS

by

J KUIPERS and H PLOOS van AMSTEL  
Stevin-Laboratory  
Technical University, Delft

Buckling strength of plywood.

Results of tests and recommendations for calculations.

1. Summary.

Tests have been carried out on 100 specimens of Canadian Oregon pine-plywood to verify that a reasonable good agreement exists between the buckling theories and the real behaviour of plywood. From load-deflection curves values for a critical buckling strength can be determined, which are in good agreement with theoretical values in the case of simply-supported edges. A clamped boundary condition could not be realised in such a way that the theoretical values were approximated. For design purposes this condition should not be presumed. Attention has been paid to combinations of normal and shear stresses on the basis of theoretical considerations. This leads to proposals for the scope of design- and calculation - recommendations, which were not worked out in detail here.

2. The investigation.

2.1 Object.

The object of the investigation is to verify that plywood follows the usual buckling theories and that the use of the different mechanical properties as laid down in design guide lines lead to sufficient accuracy in the prediction of the buckling strength.

A further goal of the investigation is to deduce safe design rules for the calculation of structures and structural parts, where plywood is loaded in compression and/or shear in its plane.

2.2 Theory.

Plywood has been assumed to behave like an orthotropic linear elastic material.

On the basis of the differential equation of the rectangular orthotropic plate together with an assumed curved plane after buckling an equilibrium state can be found if such a plate is loaded in its plane, having certain bound-

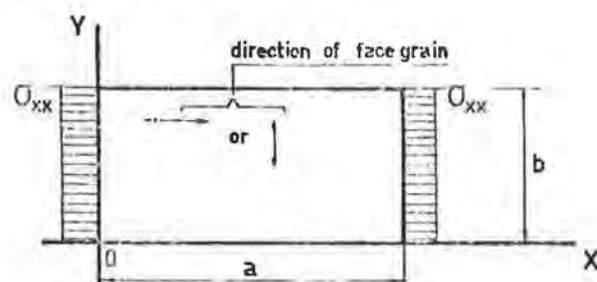

fig. 1.

dary conditions along its sides.

If for a rectangular plate, simply supported along its four sides the curved plane after buckling is

$$W_z = A_{mn} \sin \frac{n\pi}{a} x \sin \frac{m\pi}{b} y,$$

the smallest value of the stress  $\sigma$  in fig 1, necessary to accomplish this equilibrium state is found to be:

$$\sigma_{cr} = - \frac{4\pi^2}{b^2 t} \left( N_x \frac{m^2 b^2}{4a^2} + N_{xy} \frac{n^2}{2} + N_y \frac{n^4 a^2}{4m^2 b^2} \right),$$

where  $N_x = \frac{E_x t^3}{12(1-\nu_x \nu_y)}$  ;  $N_y = \frac{E_y t^3}{12(1-\nu_x \nu_y)}$  ;  $N_{xy} = \frac{1}{2} G I_w + 1/2(\nu_x N_y + \nu_y N_x)$

and where m and n are the number of half-waves in X- and Y- direction respectively.

$$\text{If } \frac{a}{b} = \beta; \alpha_v = \beta \sqrt{\frac{N_y}{N_x}}; \eta = \frac{N_{xy}}{\sqrt{N_x N_y}}$$

the formula for the critical stress becomes

$$\sigma_{cr} = - \frac{4\pi^2}{b^2 t} \sqrt{N_x N_y} \left( \frac{m^2}{4\alpha_v^2} + \frac{1}{2} \eta n^2 + \frac{n^4 \alpha_v^2}{4m^2} \right) = - K \frac{4\pi^2}{b^2 t} \sqrt{N_x N_y}.$$

where K = "buckling factor"

Generally in the short direction ( or better: the not-loaded direction) of the plate only one half-wave will be developed; in that case n = 1 and

$$K = \frac{m^2}{4\alpha_v^2} + \frac{1}{2} \eta + \frac{\alpha_v^2}{4m^2}$$

Values of K have been given in fig. 2.

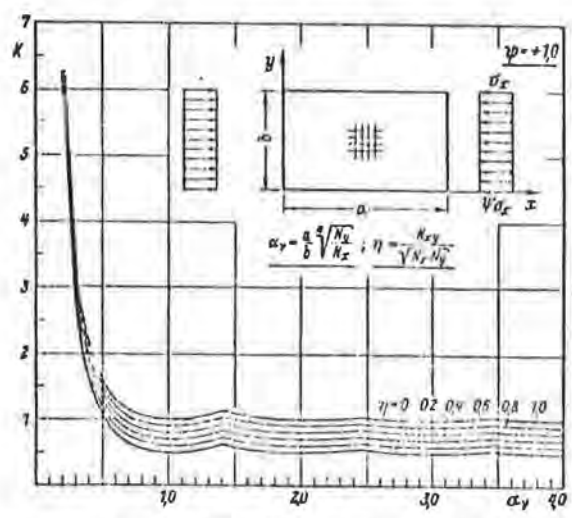
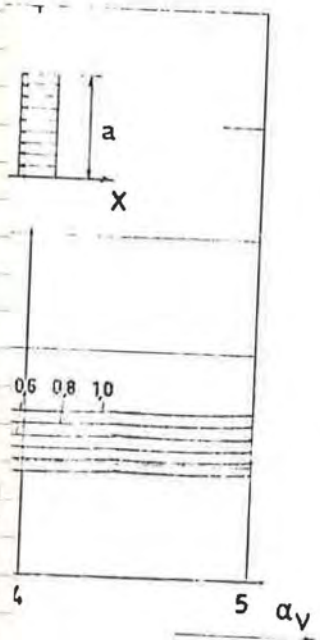

fig.2. Values of K for plates with all sides simply supported.

given a

$$\sqrt{N_x N_y} \cdot K$$



amped in;

two  
n tested.

Substrat Herstellung.

1. C/D-WIS parallel Halbburg.

Stichtafel: Lamm 6-2-1. 20.9.76

Formeln aufgeben und prüfen müssen (siehe Kolben I. Nr. 8)

für  $k$ :

$$J_w = \rho \cdot J_{w11} \rightarrow \frac{J_w}{2F} = \rho \frac{J_{w11}}{2F} = k_w^2 = \rho \cdot l_x^2 = \frac{1}{1+k} \cdot l_x^2$$

$$k_w^2 = \frac{J_w}{2F} = \frac{J_w}{2F} = \frac{J_w}{2F} \cdot (1+k)$$

Handung: D/N-Formel erläutern - Formeln aufgeben für 8 Mege

20.1.77

b mm		$\beta = a/b$ (see fig 1)										$n_\beta$
		$\frac{1}{2}$	1	$1\frac{1}{2}$	2	$2\frac{1}{2}$	3	$3\frac{1}{2}$	4	$4\frac{1}{2}$		
400	tests // grain $\rightarrow \sigma_{  }$	"	"	"	"	"	"	-	-	-	9	
	tests $\perp$ grain $\rightarrow \sigma_{\perp}$	"	"	"	"	"	"	-	-	-	6	
600	tests // grain $\rightarrow \sigma_{  }$	"	"	"	"	"	"	-	-	-	6	
	tests $\perp$ grain $\rightarrow \sigma_{\perp}$	"	"	"	"	-	-	-	-	-	4	
											25	

For rectangular plates with clamped edges Lekhnitskii has given a solution from which follows a critical stress

$$\sigma_{cr} = \frac{4\pi^2}{b^2 t} \sqrt{N_x N_y} \left( \frac{m^2}{4\alpha_v^2} + \frac{2}{3} \eta + \frac{4}{3} \frac{\alpha_v^2}{m^2} \right) = - \frac{4\pi^2}{b^2 t} \sqrt{N_x N_y} \cdot K$$

For this case values of K have been given in fig. 3.

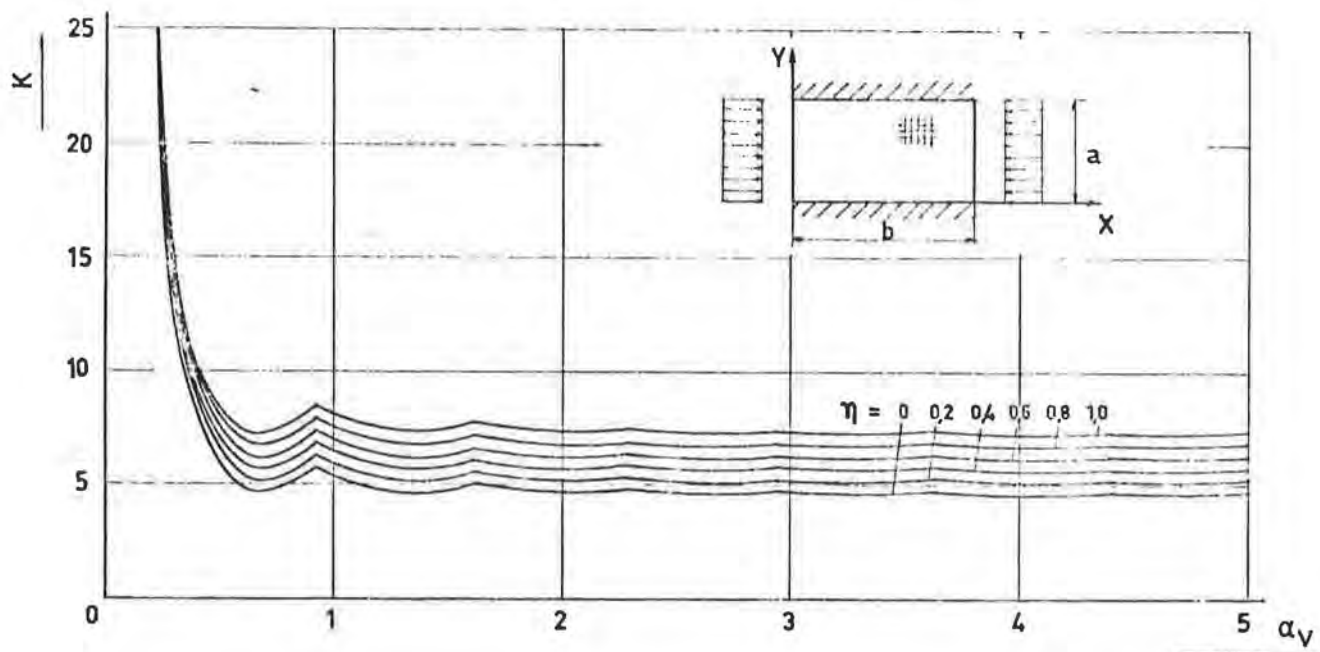

fig. 3.

Values of K for plates with sides //x-axis clamped in; the sides //y-axis are simply supported.

### 2.3 Testprogramm.

To control the validity of the theories Oregonpine specimens of two thicknesses (8 resp 13 mm) and of different dimensions have been tested. Data of the test programm is been given in table 1.

Table 1. Testprogramm

b mm		$\beta = a/b$ (see fig 1)									$n_\beta$
		$\frac{1}{2}$	1	$1\frac{1}{2}$	2	$2\frac{1}{2}$	3	$3\frac{1}{2}$	4	$4\frac{1}{2}$	
400	tests // grain $\rightarrow \sigma_{//}$	"	"	"	"	"	"	"	"	"	9
	tests $\perp$ grain $\rightarrow \sigma_{\perp}$	"	"	"	"	"	"	-	-	-	6
600	tests // grain $\rightarrow \sigma_{//}$	"	"	"	"	"	"	-	-	-	6
	tests $\perp$ grain $\rightarrow \sigma_{\perp}$	"	"	"	"	-	-	-	-	-	4
											25

Each test specimen is made in the two thicknesses 8 and 13 mm and furthermore two kinds of supports were used. In this way 25 x 2 x 2 = 100 buckling tests were done.

In all cases Canadian OregonPine-plywood, of the quality Select Sheating; Ext 1 was used. The test specimens were stored in the unconditioned laboratory hall for several months; the moisture content was 8 to 10%.

From each test specimen the thickness t, the length a and the width b were measured, furthermore the stiffness properties

$$N_x = \frac{E_x t^3}{12(1-\nu_x \nu_y)} ; N_y = \frac{E_y t^3}{12(1-\nu_y \nu_x)} \text{ and } N_{xy} = \frac{1}{2}GI_w + \frac{1}{2}(\nu_x N_y + \nu_y N_x)$$

$$\approx \frac{1}{6} Gt^3 \text{ were determined}$$

With these quantities the values of the governing factors

$$\alpha = \beta \sqrt[4]{\frac{N_y}{N_x}} \text{ and } \eta = \frac{N_{xy}}{\sqrt{N_x N_y}}$$

could be calculated, and then also the critical stresses with the help of the buckling factors K from the guirlande-curves of fig 2 and fig. 3.

Table 2 Values of  $\alpha$

b mm	t mm	load	edge cond	$\beta =$									
				$\frac{1}{2}$	1	$1\frac{1}{2}$	2	$2\frac{1}{2}$	3	$3\frac{1}{2}$	4	$4\frac{1}{2}$	
400	8	//	s	0,41	0,60	1,03	1,19	1,59	1,87	2,30	2,37	2,61	
			cl	0,39	0,59	0,98	1,27	1,56	1,87	2,10	2,22	2,76	
	s		0,45	0,85	1,12	1,39	1,80	2,00	2,56	2,71	3,07		
	cl		0,47	0,81	1,08	1,58	2,03	2,29	2,50	2,48	3,23		
	13	⊥	s	0,73	0,71	2,09	2,71	3,30	4,01				
			cl	0,81	1,46	2,16	3,63	--	4,00				
	s		0,72	1,23	1,93	2,56	3,08	3,43					
	cl		0,74	1,40	5,60	2,23	--	3,59					
600	8	//	s	0,28	0,52	0,80	0,94	1,20	1,53				
			cl	0,26	0,60	0,96	1,65	1,61	1,91				
	s		0,38	0,73	1,10	1,55	1,74	2,06					
	cl		0,50	0,75	1,29	1,38	2,00	2,15					
	13	⊥	s	0,89	1,92	2,78	3,30						
			cl	0,71	1,68	2,22	2,75						
	s		0,65	1,38	1,92	2,91							
	cl		0,64	1,58	1,61	2,23							

s = simple supported

cl = clamped

From table 2 it can be seen that  $\alpha$ -values range from ca 0,20 to ca 3 ã 4, which means that in fig. s 2 and 3 horizontally a wide scale is reached.

2.4 Test set-up.

All bending tests to determine values of  $N_x$  and  $N_y$  were carried out by simple means (see foto's);  $N_{xy}$  was found by a four point loading system according to Nadaĩ (fig.4), from which can be calculated

$$G = \frac{3l_1 l_2 F}{wt^3}$$

and hence

$$N_{xy} = 1/6 Gt^3$$

Especially in this last case only small loads were used to prevent creep.

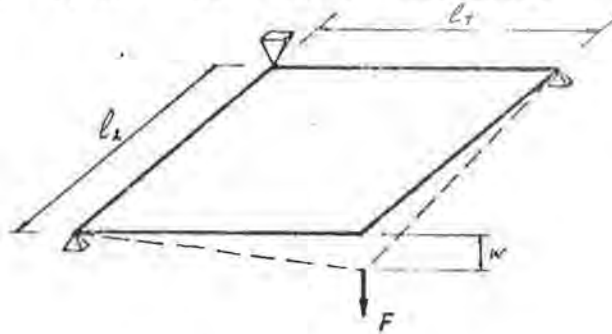

fig.4.

The buckling tests were carried out in a frame as given in fig. 5, where also the realisation of the simple supports along the sides and of the clamped condition can be seen. During the tests the deformations of the plate normal to its plane were measured; see also photographs.

3. Test results.

1. The load cells at the underside (direct loaded) showed a higher value then the upper one. The difference, caused by the friction between the plywood and the steel edge-blocks, was sometimes rather large:

$\sigma_{up} = 0,9 \text{ ã } 0,6 \sigma_{below}$ . This difference has also given way to the occurence of the buckling fields gradually from the under edge to the upper end of the plate.

The critical values of the plate given in the following have been determined as the mean values for the different buckling fields seperate.

These critical values themselves have been determined from the measurements of the deformations. Examples of the

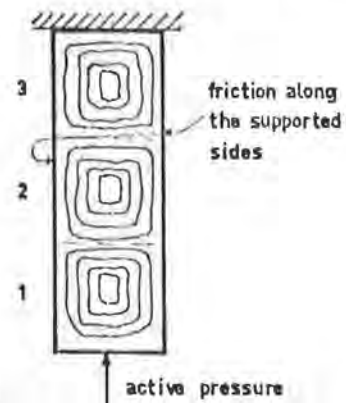

fig.6.

relation between the stress and the displacements normal to the plane

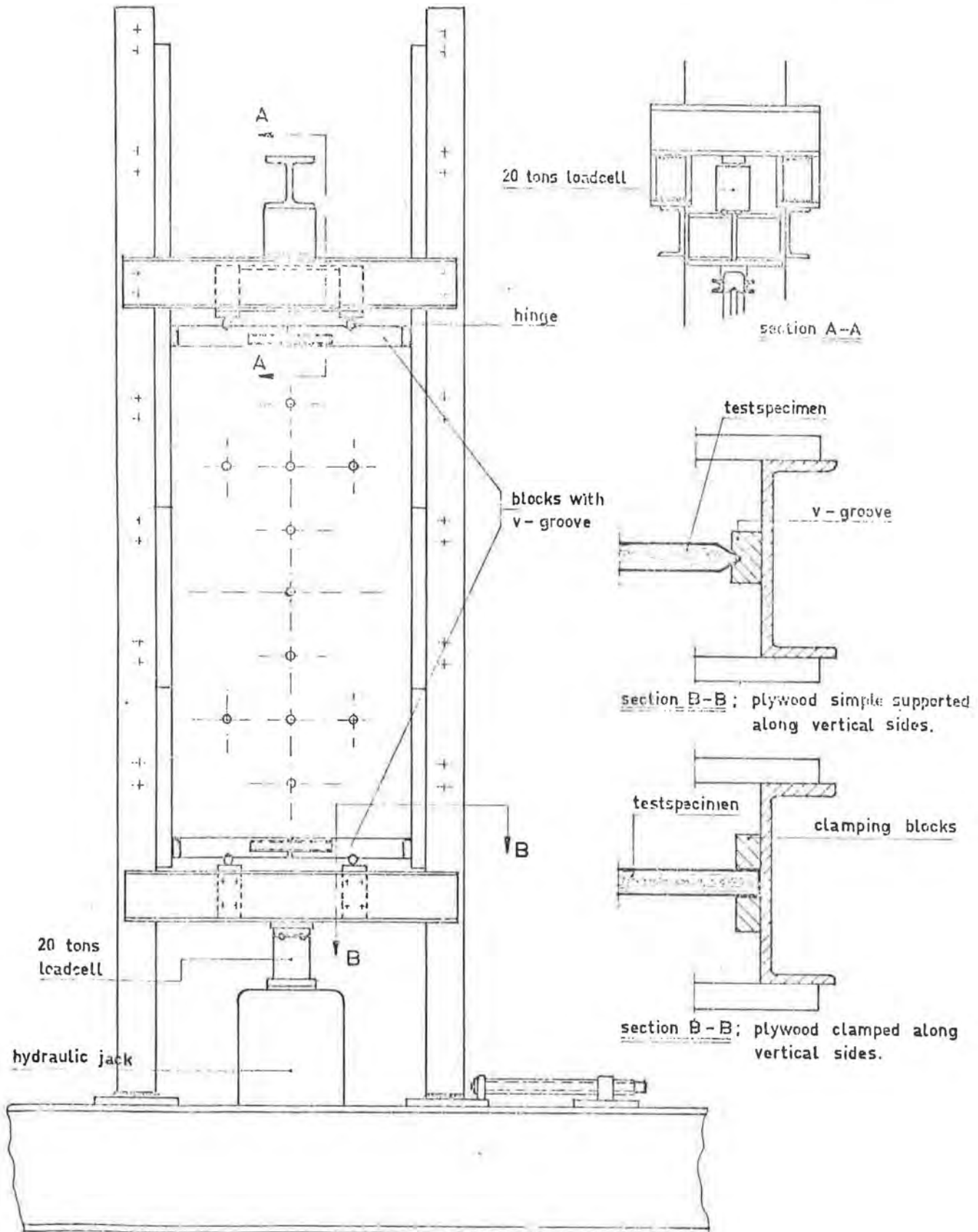
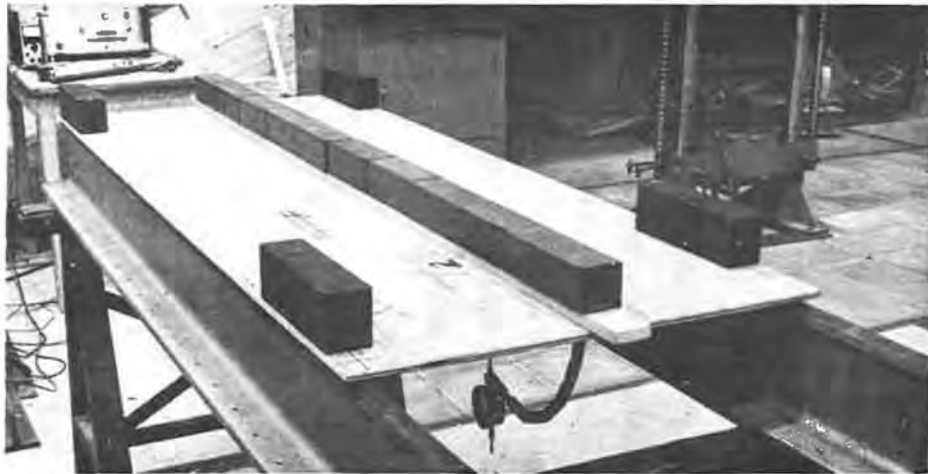
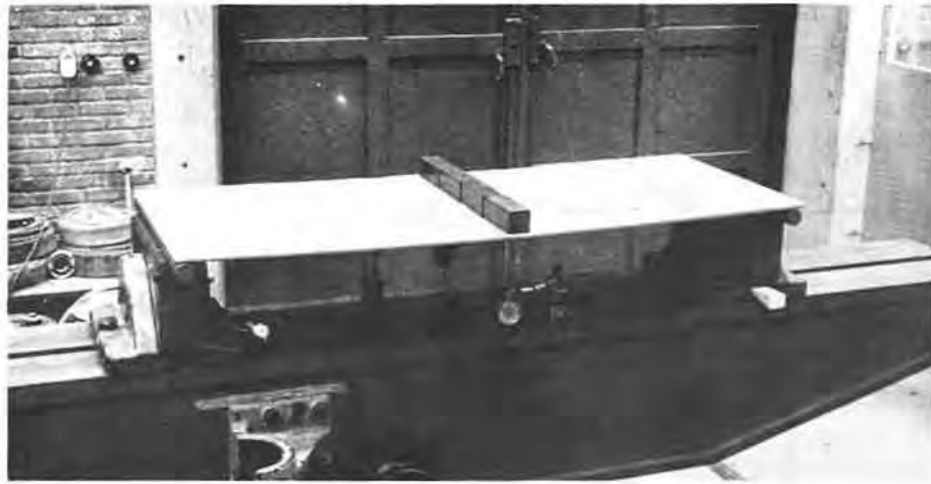

fig. 5.



Bending tests for the determination of  $N_x$  and  $N_y$ .



Simply supported test specimen,  
loaded parallel to direction of face  
grain.  $\beta = 4$  ; 3 halfwaves.



Test specimen with clamped vertical  
sides. Face veneer horizontal, that's  
 $\perp$  to the direction of the load.  
 $\beta = 3$  ; 4 halfwaves.

have been given in fig. 7. It can clearly be seen that right from the beginning of the loading procedure the originally existing excentricities<sup>1)</sup> lead to increasing deformations, which after some time follow a nearly straight line. The critical stresses were determined as given in the figures 7. From fig. 7 it is clear that during the tests the deformation was

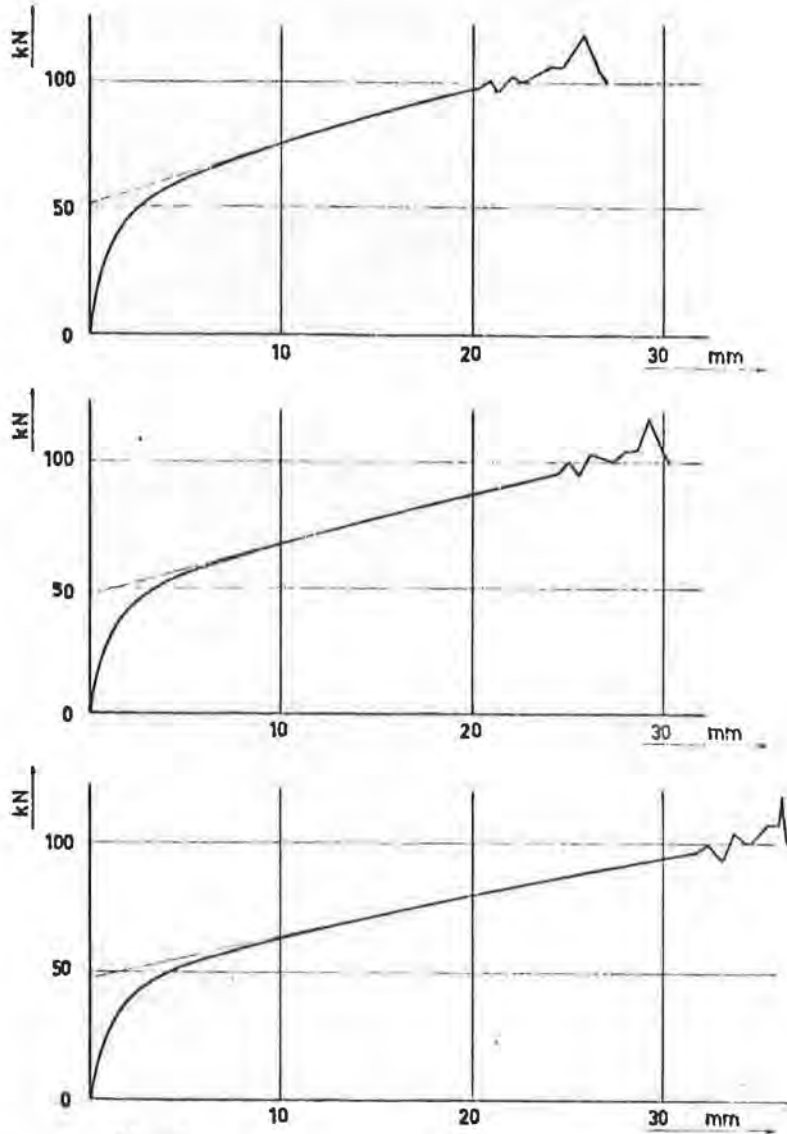

fig.7.

gradually growing; there was no sign of a sudden occurrence of buckling as was found in the investigation described in [3]. This different behaviour could possibly be the effect of other boundary conditions. In [3] the simple support was made as shown in fig. 8 b, where half-round laths were glued to the plywood. In the investigation described here such a simple support was made as shown in fig. 8 a (cf also fig. 5.).

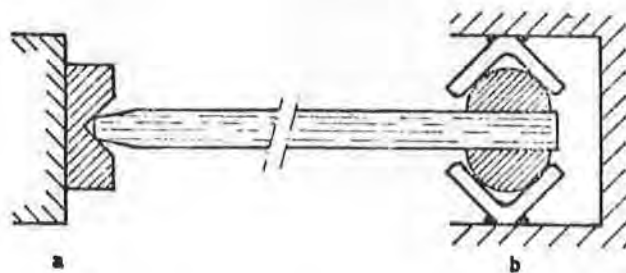

fig.8.

1) Initial excentricities were measured from  $\frac{1}{2}$  to 9% from the shortest side of the plywood panel.

In most cases the failing load is much higher than the critical load. It must be added however that this "post-buckling-behaviour" was much stronger with longer plates than with shorter ones, and that this effect disappeared with the very short plates, where instead the compressive strength was the governing property.

In most cases the highest load caused a failure in the plywood plate like in fig. 9.

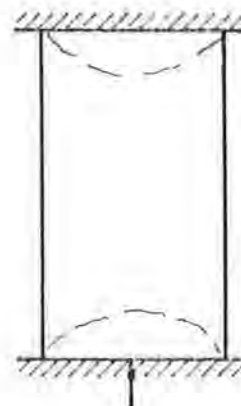

fig.9.

Without giving all the test results individually<sup>1)</sup>, the best and quickest information about the outcome of the investigation may be found in some graphs. These graphs show the relationship between the values of  $\sigma_{crit}$  from the tests with the calculated values. These calculations have been made in two manners: once with the mechanical properties as found with the preliminary tests (see graphs I and II) and secondly with the properties as laid down in the TGH<sup>2)</sup>; these last-mentioned values are design values which are supposed to be somewhat on the safe side ("low mean value") - (see graphs III and IV).

From the results it may be concluded that the theoretically calculated buckling strength is in good accordance with the test results, at least for the simply supported plates. For the plates with clamped edges it appears however that the test results are essentially lower than the calculated values. Also from the deformations it becomes clear that the supposed cosine line between the clamped edges does not occur but that much more a sinus-line is reached. This means that even the rather heavy clamping pressure

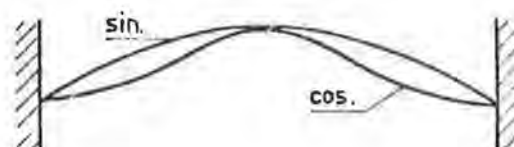

fig.10.

1) See therefore [ 4 ]

2) Tables and Graphs for the calculation of timber structures (Dutch language) editor Centrum voor Houtresearch - Houtvoorlichtingsinstituut Amsterdam.

along the steel clamping blocks is not enough to realise this theoretical situation. It must be doubted therefore if in practice such clamped edges can be effected.

Two essential conclusions may be repeated:

- 1) there is a good conformity between the critical stresses as determined according to fig.7. for Oregon Pine plywood and the theoretical values, and
- 2) it seems that for practical purposes clamped edges cannot be realised.

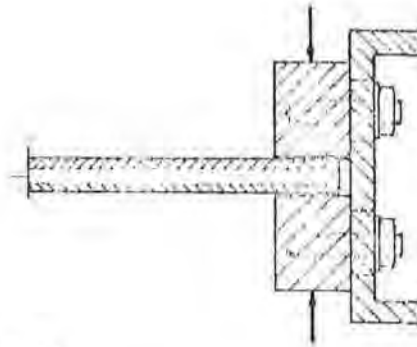

fig.11.

4. Recommendations for design and calculations.

Assuming on the basis of the foregoing that the theories developed by several authors are a good tool for the prediction of the behaviour of plywood, the theory has been elaborated for more complex situations. These theoretical results lead to some design rules after some simplifications have been made.

4.1 Theoretical values for different loading conditions.

In the following it is assumed that a plywood plate can be loaded with normal and with shear stresses along the sides. The theory is limited to combinations of normal stresses which are linear distributed and shear stresses which are uniform along the sides.

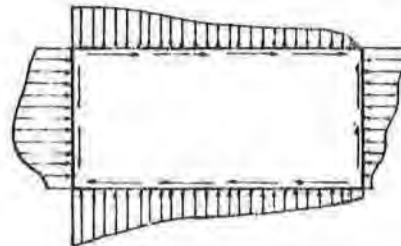

fig.12.

Both cases will be dealt with separately and afterwards combinations will be studied.

4.1.1 Normal stresses.

For the orthotropic material it can be shown that the critical stress

$\sigma_{cr x}$  may be calculated following

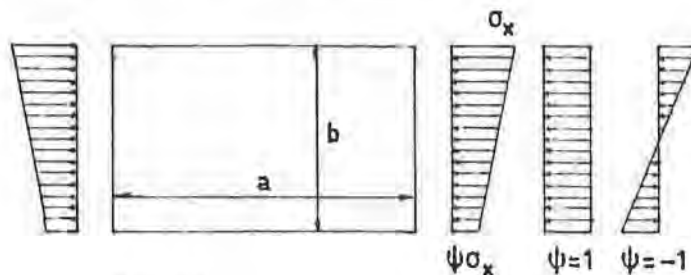

fig.13.

$$\sigma_{cr x} = K \frac{4\pi^2}{h^2 t} \sqrt{N_x N_y}$$

where

$\sigma_x$  = greatest value of the compressive stress

$\Psi \cdot \sigma_x$  = the other normal stress

$\sigma_{crx}$  and  $\Psi \sigma_{crx}$  : the critical values of  $\sigma_x$  and  $\Psi \sigma_x$

$N_x$  and  $N_y$  : plate stiffnesses as defined before

$K$  = buckling factor, the value of which depends on  $\alpha_v = \beta \sqrt{\frac{N_y}{N_x}}$  as well as on  $\psi$ . and on  $\eta = \frac{N_{xy}}{\sqrt{N_x N_y}}$

Guirlande curves for different values of  $\psi$  and dependent on  $\alpha_v$  have been given in fig. 14 . It appears that  $\psi$  and  $\eta$  both have great influence. For constant values of  $\psi$  and  $\eta$  the effect of  $\alpha_v$  is less important if  $\alpha_v > 1$  ; at least for design purposes it seems to be justified to neglect this effect. This means that then the effect of  $\beta = \frac{a}{b}$  and of the number of half-waves don't play a role anymore. This leads to a graph V.

If, like in [3]  $v_x = v_y = 0$ , then

$$N_x = \frac{E_x t^3}{12} , N_y = \frac{E_y t^3}{12} , N_{xy} = \frac{E_{xy} t^3}{6} , \text{ and } \eta = \frac{2E_{xy}}{\sqrt{E_x E_y}} ,$$

$$\text{with which } \sigma_{cr} = K \cdot \frac{\pi^2 t^2}{3b^2} \sqrt{E_x E_y} .$$

Further simplification can be reached if for a certain material or a group of materials the values of  $\eta$  deviate not too much from a mean value. In that case  $K$  could be given, e.g. for the most frequent compression load ( $\Psi = 1$ ) and for bending ( $\Psi = -1$ ); together with some realistic values of  $E_x$  and  $E_y$  real simple design formulas can be found.

#### 4.1.2. Shear stresses.

The relative simple case of constant shear stress  $\tau$  along the sides is considered here.

According to [3] it can be proven that

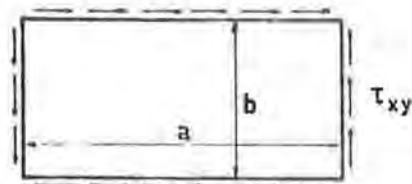

fig.14.

$$\tau_{cr} = K \frac{4\pi^2}{b^2 t} \sqrt{N_x N_y^3}$$

With  $v_x = v_y = 0$  this becomes  $\tau_{cr} = K \cdot \frac{\pi^2 t^2}{3b^2} \sqrt[4]{E_x E_y^3}$

Values of K can be read of graph VI, which graph for practical purposes can be simplified to graph VII, where the wrinkles of the curves- depending on the number of half-waves- are neglected and where for practical reason a tangent line is used for  $\alpha_v < 1$ . instead of the asymptotic curves.

The variability in the thickness and mechanical properties of plywood cannot lead to an accurate value of  $\alpha_v$ . The original graph VI gives way to very different values of K with small changes of  $\alpha_v$ . if  $\alpha_v < 1$ ; this effect has been avoided with the use of the tangent lines instead of the curves.

4.1.3. Combinations of bending- or normal stresses with shear.

If the symbols  $\sigma_{crx}$  and  $\tau_{cr}$  remain used for the plate with normal and

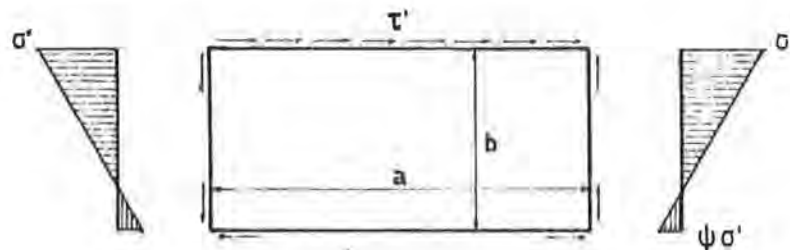

fig.15.

shearstress only, and if  $\sigma_{crx}^1$  and  $\tau_{cr}^1$  will be used for normal and shear stresses in combination, according to [3] graphs were drafted where the relationship between  $\frac{\sigma_{crx}^1}{\sigma_{crx}}$  and  $\frac{\tau_{cr}^1}{\tau_{cr}}$  is given both for the case where  $\Psi = 1$  and  $\Psi = -1$ . (cf fig.16.)

The curves in the first graph follow more or less a part of a parabola, in the second case the circle is a better approximation. For reasons of simplicity it is proposed to use a safe circular boundary

$$\left(\frac{\sigma_{crx}^1}{\sigma_{crx}}\right)^2 + \left(\frac{\tau_{cr}^1}{\tau_{cr}}\right)^2 = 0,85 (= 0,92^2)$$

This circle has been given too in fig. 16.

### 6.3 Test procedure

#### 6.3.1 Rate of application of the load

The load shall be applied with a continuous motion of the movable head to maximum load at a rate of 0.000 05 mm per millimetre of length of the specimen per second within a permissible variation of  $\pm 25$  per cent.

The time taken from the beginning of the loading to the maximum load shall be measured and recorded to the nearest **30 seconds.**

#### 6.3.2 Measurement of deformation

Data for load-deformation curves may be taken to determine the modulus of elasticity. Increments of load shall be chosen so that not less than 12 and preferably 15 or more readings of load and deformation are taken. The deformation shall be read to the nearest 0.002 mm. The deformation shall be taken over the central portion on both sides of the specimen using a gauge length of not less than 125 mm. The average of the two readings shall be used in the calculation of the modulus of elasticity. Automatic load and deformation recording apparatus may be used provided the curves obtained are of sufficient magnitude to allow accurate measurement of load and deformation.

## 6.4 Calculations

### 6.4.1 Compression stiffness

The specimen compression stiffness shall be **calculated** from

$$EA = \frac{\Delta P L}{\Delta L}$$

where EA = compression stiffness for a 200 mm wide specimen, N

$\Delta P$  = increment of load on the straight line portion of the load-deformation curve, N

L = gauge length, mm

$\Delta L$  = increment of deformation over the gauge length L, mm

The compression stiffness shall also be stated for a panel of width 1 m by multiplying the specimen stiffness by the factor 5.

If the compression modulus of elasticity (E) is subsequently calculated from the compression stiffness, the method of specifying the area (A) must be stated.

### 6.4.2 Ultimate compression strength

The ultimate compression strength of the specimen of width 200 mm is the maximum compression load resisted by the specimen.

The ultimate compression strength shall also be stated for a panel of width 1 m by multiplying the specimen ultimate compression strength by the factor 5.

#### 6.4.3 Ultimate compression stress

The ultimate compression stress shall be calculated from

$$\sigma = \frac{P}{A}$$

where  $\sigma$  = ultimate compression stress, N/mm<sup>2</sup>

P = maximum compression load, N

A = cross-sectional area, mm<sup>2</sup>

The method of specifying the cross-sectional area shall be stated.

#### 6.5 Moisture content and density

After each test, samples which are to be used to measure the moisture content and density shall be cut from the specimen. The samples shall have a minimum volume of 50 000 mm<sup>3</sup> and shall be free of visible knots, knot holes, core gaps and other voids in any ply.

The moisture content and density of each test specimen shall be determined in accordance with **clauses** 12 and 13.

## 7 Tension

### 7.1 Test specimen

#### 7.1.1 Measurements

The method of taking measurements and the type of equipment to be used shall be in accordance with ISO/DIS 3804: Plywood - Determination of dimensions of test pieces.

The specimen thickness shall be measured to **the nearest** 0.02 mm at four points, two on each edge 300 mm from each end, and the average recorded. The specimen width shall be measured to the nearest 1 mm at two points 300 mm from each end, and the average recorded.

When needed for the interpretation of test results, the thickness of each ply shall be measured to the nearest 0.02 mm at the same points at which the specimen thickness is measured.

#### 7.1.2 Size of specimen

The test specimen shall be rectangular in cross-section.

The width of the specimen shall be 250 mm and its length shall be 1200 mm.

#### 7.1.3 Sampling of test specimens from a panel

The size of the specimens and the purpose of the tests precludes the standardisation of a cutting schedule based on the position of the specimens within the panel.

Since the purpose of the tests is to determine the weakest

cross section of width 250 mm, the specimens shall be cut from the panel so that the worst defects permitted by the grade occur in the specimen.

Four test specimens, of which two shall have the grain direction of the face plies parallel to the length and two perpendicular to the length, shall be cut from each panel.

## 7.2 Loading method and equipment

The specimen shall be held in grips which apply the required forces to the specimen without influencing load at, or location of, failure. Such devices shall not apply a bending moment to the test section, allow slippage under load, or inflict damage or stress concentrations to the test section. (Figures 4 and 5 illustrate the test set-up and grips.)

For ideal test conditions, the grips should be self-aligning. When self-aligning grips are not available, the specimen may be clamped in the heads of a universal-type testing machine with wedge-type jaws.

## 7.3 Test procedure

### 7.3.1 Rate of application of the load

The load shall be applied with a continuous motion of the movable head to the maximum load at a rate of 0.000 05 mm of net length of specimen per second, within a permissible

variation of  $\pm 25$  per cent. The net length of the specimen shall be taken as distance between the inside faces of the grips.

The time taken from the beginning of the loading to the maximum load shall be measured and recorded to the nearest 30 seconds.

#### 7.3.2 Measurement of deformation

Data for load-deformation curves may be taken to determine the modulus of elasticity. Increments of load shall be chosen so that not less than 12 and preferably 15 or more readings of load and deformation are taken. The deformation shall be read to the nearest 0.002 mm. The deformation shall be taken over the central portion on both sides of the specimen using a gauge length of not less than 125 mm. The average of the readings shall be used in the calculation of the modulus of elasticity. Automatic load and extension recording apparatus may be used provided the curves obtained are of sufficient magnitude to allow accurate measurement of load and extension.

### 7.4 Calculations

#### 7.4.1 Tension stiffness

The specimen tension stiffness shall be calculated from:

$$EA = \frac{\Delta PL}{\Delta L}$$

where  $EA$  = tension stiffness for a 250 mm wide specimen, N

$\Delta P$  = increment of load on the straight line portion of the load-deformation curve N

$L$  = gauge length, mm

$\Delta L$  = increment of deformation over the gauge length  $L$ , mm

The tension stiffness shall also be stated for a panel of width 1 m by multiplying the specimen stiffness by the factor 4.

If the tension modulus of elasticity ( $E$ ) is subsequently calculated from the tension stiffness, the method of specifying the area ( $A$ ) must be stated.

#### 7.4.2 Ultimate tension strength

The ultimate tension strength of the specimen of width 250 mm is the maximum tension load resisted by the specimen.

The ultimate tension strength shall also be stated for a panel of width 1 m by multiplying the specimen ultimate tension strength by the factor 4.

#### 7.4.3 Ultimate tension stress

The ultimate tension stress shall be calculated from:

$$\sigma = \frac{P}{A}$$

where  $\sigma$  = ultimate tension stress,  $N/mm^2$

$P$  = maximum tension load, N

$A$  = cross-sectional area,  $mm^2$

The method of specifying the cross-sectional area shall be stated.

#### 7.5 Moisture content and density

After each test, samples which are to be used to measure the moisture content and density shall be cut from the specimen. The samples shall have a minimum volume of 50 000 mm<sup>3</sup> and shall be free of visible knots, knot holes, core gaps and other voids in any ply.

The moisture content and density of each test specimen shall be determined in accordance with **clauses** 12 and 13.

## 8 Panel shear

### 8.1 Test specimen

#### 8.1.1 Measurements

The method of taking measurements and the type of equipment to be used shall be in accordance with ISO/DIS 3804: Plywood - Determination of dimensions of test pieces.

The specimen thickness shall be measured to the nearest 0.02 mm at four points, two on each edge 100 mm from each end and the average recorded. The specimen length shall be measured to the nearest 1 mm at two points 50 mm from each side, **and the average recorded.**

When needed for the interpretation of test results the thickness of each ply shall be measured to the nearest 0.02 mm at the same points at which the specimen thickness is measured.

#### 8.1.2 Size of specimen and method of manufacture

The dimension of the test specimen shall be as shown in figure 6.

The plywood sample to which the rails are glued shall be 600 mm long and not less than 425 mm wide. The width shall be not less than 450 mm wide if the thickness of the plywood is greater than 19 mm.

The face grain of 3-ply panels shall be orientated across the width in order to preclude failure through buckling. The face grain orientation of plywood having five or more plies may be in either direction, but the same across-

-the-width orientation is recommended. Any localized features to be studied shall be included in the central 150 mm by 600 mm area.

Rails having minimum dimensions of 35 mm by 115 mm by approximately 700 mm long shall be glued to both sides of the plywood sample at each edge. The rails shall be spaced 200 mm apart with their ends even with the plywood sample at two diagonally opposite corners as shown in figure 6. Prior to gluing, the rails and the specimen shall be conditioned to the approximate moisture content at which the specimen is to be tested.

After gluing, a bevel of approximately 14 deg shall be cut on the end of each pairs of rails where the major compression load is to be applied.

It is recommended that the time between gluing of rails and testing be only long enough to ensure adequate curing of the adhesive.

### 8.1.3 Sampling of test specimens from a panel

The specimens shall be cut from the panel so that the worst defects permitted by the grade occur in the specimen. If core gaps are permitted in the grade they shall be included in the test specimens.

Four test specimens shall be cut from each panel.

## 8.2 Loading method and equipment

The load shall be applied so that the resultant of the forces applied to a pair of rails shall be a single force acting along the longitudinal axis of the test specimen both in the plane of the specimen and in the thickness direction. The load on the rails shall be applied by separating the machine crossheads.

Spherical seats, two-way pivots, or other devices shall be used to **ensure** approximately equal division of major compressive loads to the two rails on opposite sides of the panel.

A suitable apparatus for applying the loads to the rails is shown in figure 7. **The opposing** collinear forces applied to pins located on the longitudinal axis of the specimen and perpendicular to its plane are divided into two components: (1) a major compression force applied to the end of the rail by a loading yoke free to pivot about the pin; and (2) a minor lateral force applied to the projecting end of the rail by a block that keeps the pin spaced the **correct** distance from the rail it loads. The major compressive load is applied through a two-way rocker and bearing plate arrangement to distribute the load uniformly to the rail end. **The rigid block applying the lateral force to the projecting rail ends ensures that the pin remains perpendicular to the plane of the specimen.**

### 8.3 Test procedure

#### 8.3.1 Rate of application of the load

The movement of the crosshead of the testing machine shall be continuous at a rate of 0.0333 mm/s  $\pm$  25 per cent.

The time taken from the beginning of the loading to the maximum load shall be measured and recorded to the nearest 30 seconds.

#### 8.3.2 Measurement of deformation

Data for load-deformation curves may be taken to determine the modulus of rigidity. Increments of load shall be chosen so that not less than 12 and preferably 15 or more readings of load and deformation are taken. The deformation shall be read to the nearest 0.002 mm.

The deformation shall be taken on both sides of the specimen over a 200 mm gauge length located on the compression diagonal which passes through the central point of the shear area and which is inclined at 45 deg to the rails. The centre of the gauge length shall be at the centre of the shear area. The average of the two readings shall be used in the calculations of the modulus of rigidity. Automatic load and deformation recording apparatus may be used provided the curves obtained are of sufficient magnitude to allow accurate measurement of load and deformation.

## 8.4 Calculations

### 8.4.1 Ultimate panel shear stress

The ultimate panel shear stress shall be calculated from

$$\tau = \frac{P}{Lt}$$

where  $\tau$  = ultimate panel shear stress,  $N/mm^2$

$P$  = maximum load, N

$L$  = length of shear area, mm

$t$  = thickness of shear area, mm

### 8.4.2 Modulus of rigidity

The modulus of rigidity shall be calculated from

$$G = \frac{\Delta P}{2 \Delta \delta} \frac{l}{Lt}$$

where  $G$  = modulus of rigidity,  $N/mm^2$

$\Delta P$  = increment of load on the straight line portion of the load-deformation curve, N

$\Delta \delta$  = increment of deformation over the gauge length  $l$ , mm

$l$  = gauge length, mm

## 8.5 Moisture content and density

After each test, samples which are to be used to measure the moisture content and density shall be cut from the specimen. The samples shall have a minimum volume of  $50\,000\text{ mm}^3$  and shall be free of visible knots, knot holes, core gaps and other voids in any ply.

The moisture content and density of each test specimen shall be determined in accordance with **clauses** 12 and 13.

## 9 Panel shear: **alternative method of test**

### 9.1 Test specimen

#### 9.1.1 Measurements

The method of taking measurements and the type of equipment to be used shall be in accordance with ISO/DIS 3804: Plywood - Determination of dimensions of test pieces.

The specimen thickness shall be measured to the nearest 0.02 mm at the mid-points of the four sides and the average recorded.

#### 9.1.2 Size of specimen and method of manufacture

The dimensions of the test specimen shall be as shown in figure 8. The size and thickness of the reinforcing pads shall be as indicated. The pads may be made from maple, birch, beech or any other species with approximately the same strength characteristics; alternatively plywood pads may be used.

A jig for accurate location of the pads shall be used; a satisfactory method of assembly is shown in figure 9. An outline drawing of suitable test apparatus is shown in figure 10, and a photograph in figure 11.

The material shall be conditioned to standard humidity and temperature (clause 3) prior to gluing on the pads (which should also have been conditioned) and then conditioned again before testing. The tests are usually made with the face grain of the material parallel or perpendicular to the sides of the loading rig, but

tests may also be made with the grain inclined to the sides.

### 9.1.3 Sampling of test specimens from a panel

The specimens shall be cut from the panel so that the worst defects permitted by the grade occur in the specimen. If core gaps are permitted in the grade they shall be included in the test specimens.

Four test specimens shall be cut from each panel.

## 9.2 Loading method and equipment

The load shall be applied in compression along a diagonal using the test apparatus shown in figures 10 and 11.

To minimize friction, suitable bearings may be inserted at the corners of the frame. Material up to 13 mm in thickness requiring a total load of less than 45 kN may be tested by this method. For materials greater than 13 mm in thickness, the dimensions of the reinforcing blocks and the test frame would have to be increased, but at the moment it is not possible in this standard to make specific recommendations.

## 9.3 Test procedure

### 9.3.1 Rate of application of the load

The load shall be applied by compression along a diagonal. The movement of the cross-head of the testing

machine shall be continuous at a rate of 0.0333 mm/s  $\pm$  25 per cent.

The time taken from the beginning of the loading to the maximum load shall be measured and recorded to the nearest 30 seconds.

#### 9.4 Calculations

##### 9.4.1 Ultimate panel shear stress

The ultimate panel shear stress shall be calculated from:

$$\tau = \frac{0.707 P}{Lt}$$

where  $\tau$  = ultimate panel shear stress, N/mm<sup>2</sup>

P = maximum applied load, N

L = side of square panel specimen, mm (see figure 8)

t = thickness of specimen, mm

#### 9.5 Moisture content and density

After each test, samples which are to be used to measure the moisture content and density shall be cut from the specimen. The samples shall have a minimum volume of 50 000 mm<sup>3</sup> and shall be free of visible knots, knot holes, core gaps and other voids in any ply.

The moisture content and density of each test specimen shall be determined in accordance with **clauses** 12 and 13.

## 10 Modulus of rigidity

### 10.1 Test specimen

#### 10.1.1 Measurements

The method of taking measurements and the type of equipment to be used shall be in accordance with ISO/DIS 3804: Plywood - Determination of dimensions of test pieces.

The specimen thickness shall be measured to the nearest 0.02 mm at the mid-points of the four sides and the average recorded.

The length and width of the specimen shall be measured to the nearest 1 mm.

#### 10.1.2 Size of specimen

The test specimen shall be square with the thickness equal to the thickness of the material and the length and width not less than 25 nor more than 40 times the thickness.

#### 10.1.3 Direction of grain

The grain direction of the individual plies shall be parallel or perpendicular to the edges of the test specimen.

NOTE: This method of test is primarily designed for material in which the grain of the individual plies is parallel and perpendicular to the edge of the specimen. Provided however that the deflections are measured as illustrated in figure 12, it may also be used for plywood cut at other angles.

#### 10.1.4 Sampling of test specimens from a panel

The specimens shall be cut from the panel so that the worst defects permitted by the grade occur in the specimen. If core gaps are permitted in the grade they shall be included in the test specimens.

Four test specimens shall be cut from each panel.

#### 10.2 Loading method and equipment

The test specimen shall be supported on rounded supports, having a radius of curvature not greater than 6 mm at the opposite ends of a plate diagonal and loaded in a similar manner on the opposite ends of the other diagonal. In order that the loads may be applied at the corners, metal plates shall first be attached as shown in figure 12. The loading and supporting frame shall be rigid.

#### 10.3 Test procedure

##### 10.3.1 Rate of application of the load

The load shall be applied with a continuous and uniform motion of the movable head at a rate of 0.000 05 times the length of the plate in millimetres per second, within a permissible variation of  $\pm 25$  per cent.

The time taken from the beginning of the loading to the maximum load shall be measured and recorded to the nearest 30 seconds.

### 10.3.2 Measurements of deformation

The deformation shall be measured to the nearest 0.02 mm at two points on each diagonal equidistant from the centre of the plate. These measurements shall be made at the quarter points of the diagonals. The plate shall not be stressed beyond its elastic range and increments of load shall be chosen so that not less than 12 and preferably 15 load deformation readings are taken. Specimens shall be reasonably flat. Any showing excessive initial curvature shall be rejected. To eliminate the effects of any slight initial curvature, two sets of data shall be obtained, the second set with the plate rotated 90° about an axis through the centre of the plate and perpendicular to the plane of the plies. The two results shall be averaged to obtain the modulus of rigidity for the plate. A satisfactory arrangement for measuring relative deformations is indicated in figure 12; the dial readings in this case give twice the average deflection of the four points.

## 10.4 Calculations

### 10.4.1 Modulus of rigidity

The modulus of rigidity shall be calculated from:

$$G = \frac{3a^2P}{2t^3w}$$

where  $G$  = modulus of rigidity,  $N/mm^2$

$P$  = load applied to each corner,  $N$

$t$  = thickness of the plate,  $mm$

$w$  = deflection relative to the centre,  $mm$

$a$  = distance from the centre of the panel to the point where the deflection is measured,  $mm$

**Note:**

The average value of P/w may be taken from the slope of a load-deflection curve.

**10.5 Moisture content and density**

After each test, samples which are to be used to measure the moisture content and density shall be cut from the specimen. The samples shall have a minimum volume of 30 000 mm<sup>3</sup> and shall be free of visible knots, knot holes, core gaps and other voids in any ply.

The moisture content and density of each test specimen shall be determined in accordance with clauses 12 and 13.

Where additional tests are to be made on the plate a separate matched moisture specimen shall be provided when the specimen is cut out, in which case this moisture specimen shall be subjected to the same conditioning as the plate itself.

## 11 Rolling shear

### 11.1 Test specimen

#### 11.1.1 Measurements

The method of taking measurements and the type of equipment to be used shall be in accordance with ISO/DIS 3804: Plywood - Determination of dimensions of test pieces.

The thickness of the two central strips and the two cover plates shall be measured to the nearest 0.02 mm at the mid-point of their areas, and the average recorded. The widths of the central strips and the cover plates shall be measured to the nearest 0.1 mm at the mid-point of the length of the smaller area of overlap (ie at section XX in figure 13 ). The length of the smaller area of overlap shall be measured to the nearest 0.1 mm at the centre line of the specimen.

When needed for the interpretation of test results, the thickness of each ply shall be measured to the nearest 0.02 mm at the middle of the small area of overlap.

#### 11.1.2 Size of specimen and method of manufacture

The test is made on the double lap tension specimen shown in figure 13. The specimens comprise two 25 mm wide cover plates having the face grain perpendicular to their length. The cover plates are positioned so that there is a 25 mm double lap joint at one end and a 50 mm double lap joint at the other; the gap between the ends of the central strips is 6 mm. The centre strips **both have**

the face grain parallel to their lengths. The plywood strips are conditioned as required before assembly and the assembled specimens are again conditioned before testing. The glue used to assemble the specimens shall conform with the minimum requirements for type MR of BS 1204: Synthetic resin adhesives (phenolic and aminoplastic) for wood , Part 1, Gap-filling adhesives .

#### 11.1.3 Sampling of test specimens from a panel

Four test specimens shall be made from each panel.

#### 11.2 Loading method and equipment

The load shall be applied in tension along the length of the specimen. The specimen shall be held in grips which apply the required forces to the specimen without slipping and which do not apply a bending moment to the overlapping areas. Suitable apparatus is shown in figure 14.

#### 11.3 Test procedure

##### 11.3.1 Rate of application of the load

The movement of the crosshead of the testing machine shall be continuous at a rate of 0.01 mm/s  $\pm$  25 per cent.

The time taken from the beginning of the loading to the maximum load shall be measured and recorded to the nearest 30 **seconds**.

Any specimen which fails in a manner other than in rolling shear in the shorter lap **shall be rejected.**

#### 11.4 Calculations

##### 11.4.1 Ultimate rolling shear stress

The ultimate rolling shear stress shall be calculated from:

$$\tau = \frac{P}{2A}$$

where  $\tau$  = ultimate rolling shear stress,  $N/mm^2$   
 $P$  = maximum applied load, N  
 $A$  = smaller area of overlap,  $mm^2$

##### 11.5 Moisture content and density

After each test the whole of the test specimen shall be used to measure the moisture content. The moisture content shall be determined in accordance with **clause 12.**

The density, if required, may be found from samples matched to those from which the test specimens are made, or on samples cut after test from the longer tension tab ('A' in figure 13 ) clear of the area affected by the toothed grip.

## 12 Moisture content

### 12.1 Procedure

After each test a sample which is to be used to measure the moisture content shall be cut from the body of the specimen near to the point of failure. For specimens of thin material or of small size it may be desirable to use the entire specimen as a moisture sample. Where it is not possible to use the test specimen or a part of it for moisture content measurement, a separate matched moisture specimen shall be provided when the specimen is cut out. The matched specimen shall be taken from the same portion of the board as the test specimen and shall be subjected to the same conditioning.

Reference should be made to the clauses relating to each individual test for further instruction on the size of the sample and on moisture measurement.

The moisture sample shall be weighed immediately and dried in an oven at  $103 \pm 2^{\circ}\text{C}$  until approximately constant mass\* is attained. After drying the sample shall be weighed immediately to an accuracy of not less than  $\pm 0.2$  per cent.

\* Constant mass is considered to be reached when two successive weighing operations, carried out at an interval of 24 hours, do not differ by more than 0.1 per cent of the mass of the test piece.

## 13 Density

## 13.1 Procedure

A rectangular sample taken from the test specimen or the same portion of the board as the test specimen, shall be used to determine the density. Where suitable, the specimen which is prepared for moisture content measurement (12.1) may also be used to determine density.

Reference should be made to the clauses relating to each individual test for further instructions on the size of the sample.

The sample shall be measured and weighed to an accuracy of not less than  $\pm 0.2$  per cent.

## 13.2 Calculation of density

The nominal density shall be calculated from :

$$\rho = \frac{10^6 M_0}{Lbt}$$

where  $M_0$  = mass of sample, g

$L$  = length of sample, mm

$b$  = width of sample, mm

$t$  = thickness of sample, mm

Note:  $\rho$  = nominal density,  $\text{kg/m}^3$

The above density is based on the volume at test and the mass when oven-dry. If desired, the density may be obtained on the basis of mass at test/volume at test or of oven-dry mass/oven-dry volume. In each instance, the basis of the density value with respect to volume and moisture content shall be stated.

#### 14 Report

The report shall include details of the test material, the method of test, and the test results. The amount of detail given under each of these headings will depend on the purpose of the tests and shall be agreed by the test laboratory and its client prior to the commencement of the test programme.

The following material data shall normally be given: the species and nominal thickness of each veneer, the grain direction, the adhesive, the method of cutting of veneer, the overall thickness, the number of veneers, the surface treatment, the manufacturing standard and the grade of the panels from which the specimens were cut.

The following data concerning the test conditions shall normally be given: the type of test specimen (when the standard permits alternatives), the method of loading, the temperature and relative humidity at the time of test.

For individual specimens the test results shall be presented in a tabular form giving the following data: specimen dimensions, moisture content, time to failure, maximum loads, description of failure, and the calculated values of stiffness and strength. When moduli of elasticity and stresses are calculated the basis on which they have been determined (parallel plies only, full cross-section, etc) shall be stated.

Additional data may be required in some cases. This may include the following: full details of method of manufacture, actual thickness of each veneer, full details of any natural defects or manufacturing features which influence the test results, density and load-deformation diagrams.

The number of specimens tested for each property shall be stated in the test report, and if a statistical treatment of the data is possible then the value of the standard deviation or coefficient of variation for each property shall also be given, as well as the mean.

## Appendix 1

### Pure moment test for large specimens

#### A1 Introduction

Suitable equipment for the application of pure moments to the ends of large test specimens of plywood was first developed by the American Plywood Association, Tacoma, Washington DC, USA. Similar equipment was subsequently designed by the Council of Forest Industries, British Columbia, Canada. Full details of their equipment may be obtained from these organisations.

The concept of pure moment testing was later incorporated in ASTM D 3043-72: Standard methods of testing plywood in flexure. The relevant parts of this standard describing the test method in general terms and a method of determining panel curvature from the angular rotation of ends of the specimen are given below.

#### A2 Edited extract from ASTM D 3043-72: Standard methods of testing plywood in flexure.

7.1 Summary - A specially designed testing machine applies pure moments to opposite ends of the test panel through loading frames. Frames are free to move toward or away from each other during the test to preclude application of other than pure moments to the centre span of the panel. Between loading frames deflection of the neutral axis follows a circular arc. Rotational deformation between points near the ends of the arc is measured during the test by special sensing gauges resting on pins

projecting from the face of the panel at these points. The test is simple, flexible, and results are directly relatable to basic properties at large deformations.

7.3 Application and Measurement of Moments - Figure 1 illustrates application of pure moments to a specimen, by means of loading frames, and measurement of deformation. Apply equal and opposite pure moments to each end of the panel by frames. The frames shall be free to move toward or away from each other while under load to preclude application of direct tension or compression loads at large panel deformations. Support axes of the loading frames to remain in parallel relationship throughout the test (Note 1). Space bars of the loading frames sufficiently to prevent shear failures between points of load application. A bar spacing of 20 times panel thickness is suggested to preclude most, if not all, shear failures in the plane of the plies. In some cases close spacing may be entirely satisfactory.

Friction forces that tend to resist motion of the axes of the loading frames during a test may also cause significant errors. Where a cable and pulley system is employed, the use of cables of the smallest possible size consistent with loads, and relatively large pulleys will help minimize friction forces.

Speed of testing - The rotation of the load frames with respect to each other may be used to control the rate of strain of the outer fibres of the plywood as follows:

$$R = (z/90d)(3D - 4S)$$

where R = rotation speed between loading frames, rad/sec

S = load frame bar spacing between points of contact with panel, mm

D = span between outer loading frame bars, mm

d = panel thickness, mm

z = strain rate for outer fibre, mm/mm.sec.

Note 1 - These requirements dictate use of specialized equipment which may not be readily available. The principle of a commercially available flexure testing machine complying with these requirements is diagrammed in the figure below. Until further innovations are made in pure bending test equipment, use of cable and pulley equipment of this type, either purchased or constructed at the laboratory, offers the only practical means of implementing this method. This equipment is the subject of US Patent No. 3,286,516.



7.5.4 Measurement of Panel curvature by Angular Rotation - Figure 2 illustrates a suitable method of measuring angular rotations in conjunction with electronic indicating and recording equipment. One-eighth in. (3 - mm) pins project perpendicularly from the face of the panel held in a vertical position by the loading frames. These pins, threaded at one end and having a small rectangular flange, are attached to the panel either by screwing them into small holes in the face of the panel until the flange is drawn tightly against the face or by inserting the pin through a hole in the panel and drawing the flange tight by means of a nut on the opposite side of the panel. A reference rod approximately the same length as the spacing between pins is fitted at each end with an angular sensing device. Each gauge housing is provided with small ball bearings which permit free movement of the angular sensing gauge along the rod while holding it in fixed angular relationship to it. The input shaft of each rotation gauge is fitted with a flange and small V-blocks which rest on the pins projecting from the panel at each gauge point, thus transmitting the angular rotation of the panel to the gauge and supporting the rotation gauge reference rod assembly.

7.5.4.1 The rotation between the two gauge points during test is the sum of the two rotations measured at each end of the reference rod. Use of linear differential transformers as transducers permits primaries and secondaries to be wired to produce a single signal proportional to their sum for indication or recording.

7.6 Calculations- Calculate panel stiffness from test data in accordance with the following equation:

$$EI = ML/(\theta_1 + \theta_2)$$

where EI = panel bending stiffness, N.mm<sup>2</sup>

M = moment applied to the panel, N.mm

L = distance between gauge points, mm

$\theta_1 + \theta_2$  = total angular rotation between gauge points.

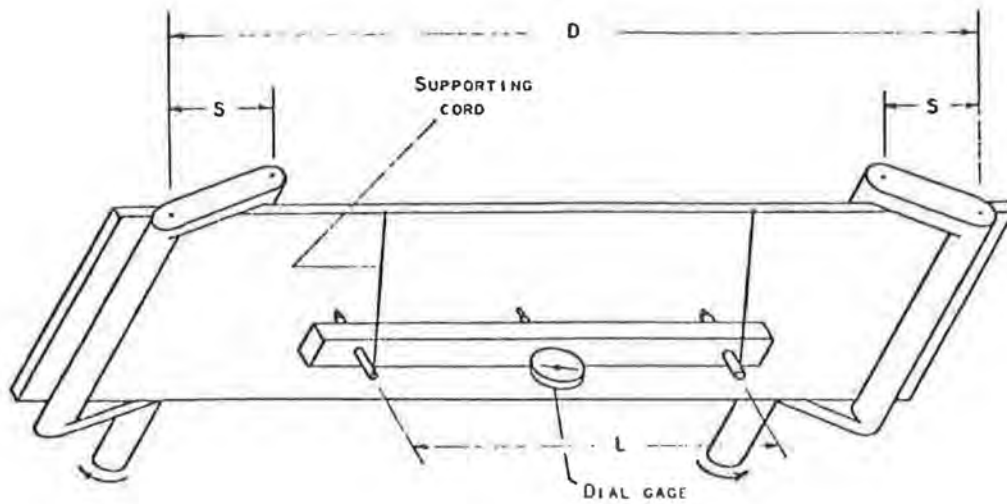

Figure 1a Use of dial gauge to measure midordinate deflection in a pure moment bending test

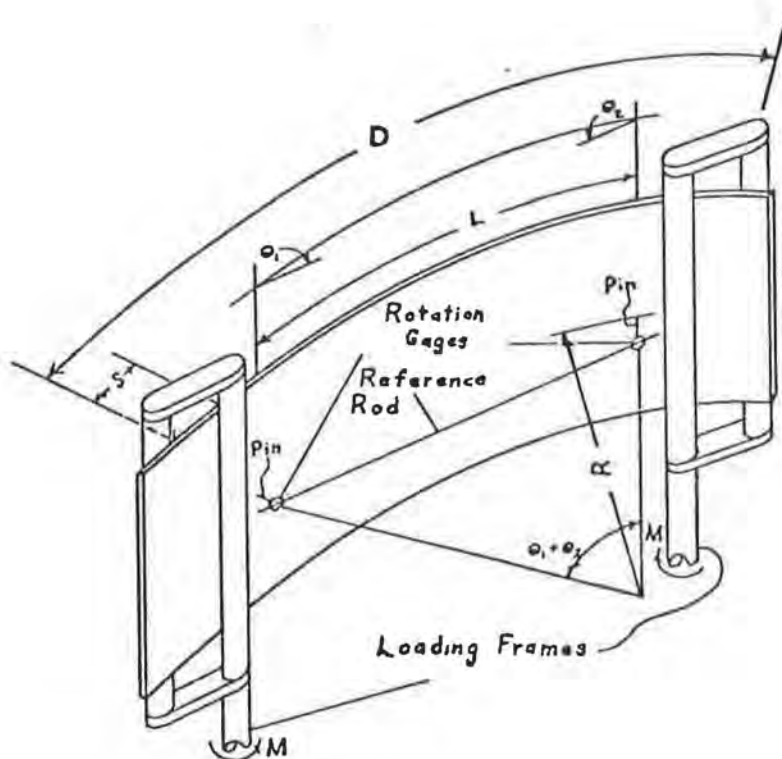
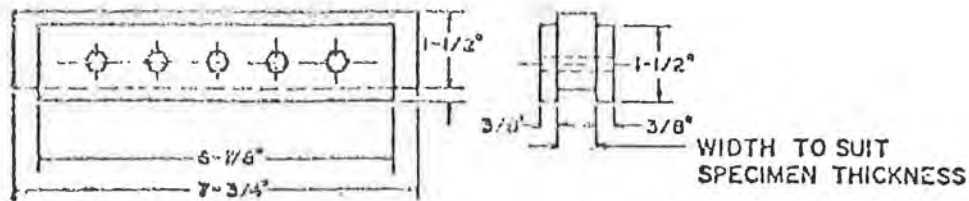

Figure 1b Pure bending test of plywood panel showing angular rotation gauges and loading frames

Figure 2 not available at time of printing

Figure 2 Static bending test of plywood using  
the alternative method of test

Lehrstuhl für  
Ingenieurholzbau u. Baukonstruktionen  
Universität (TH) Karlsruhe  
Prof. Dr.-Ing. K. Möhler



SPECIMEN LOADING BLOCKS  
2 REQ'D

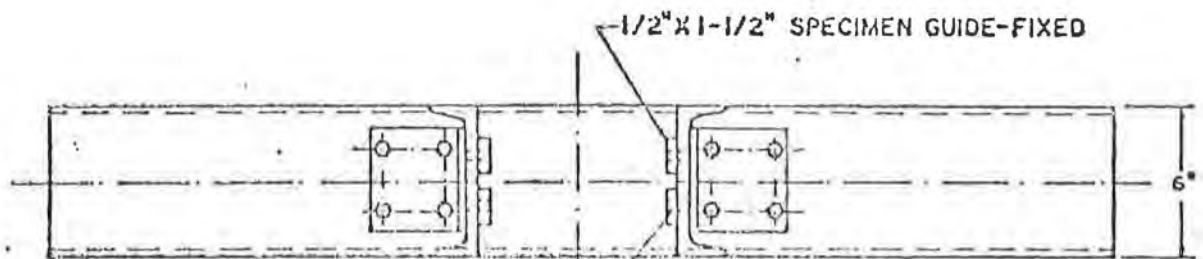

1/2" X 1-1/2" SPECIMEN GUIDE - BOLT HOLES  
SLOTTED TO ADJUST FOR  
SPECIMEN THICKNESS

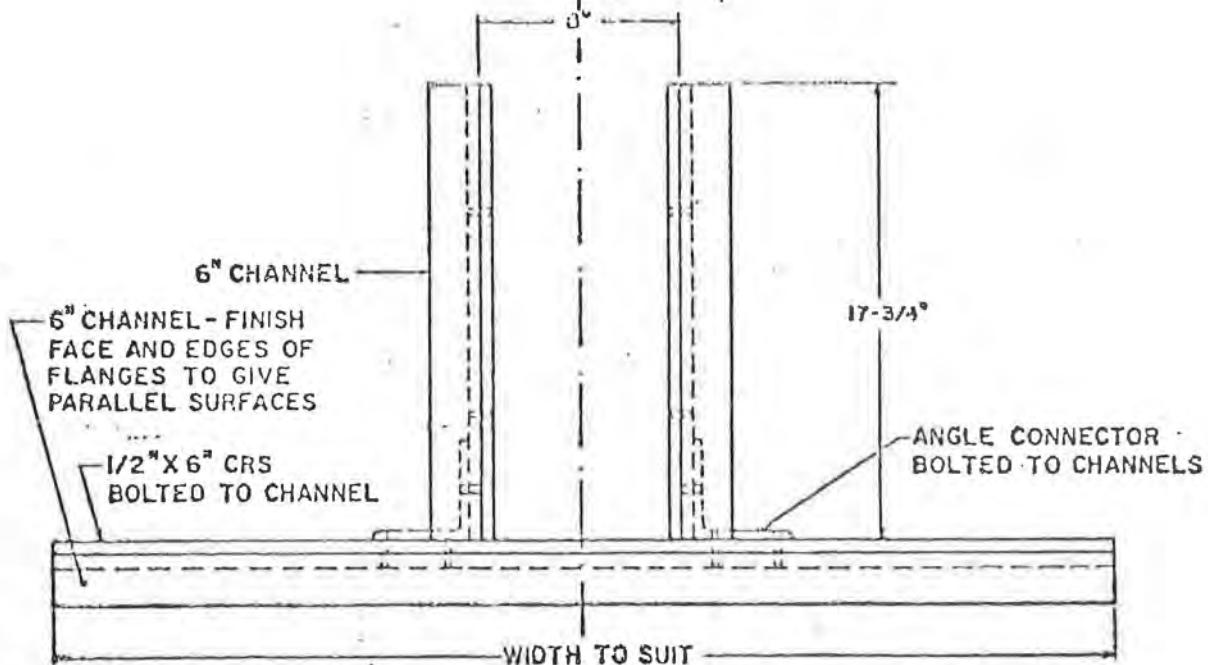

LOADING FRAME

Figure 3 Compression test apparatus

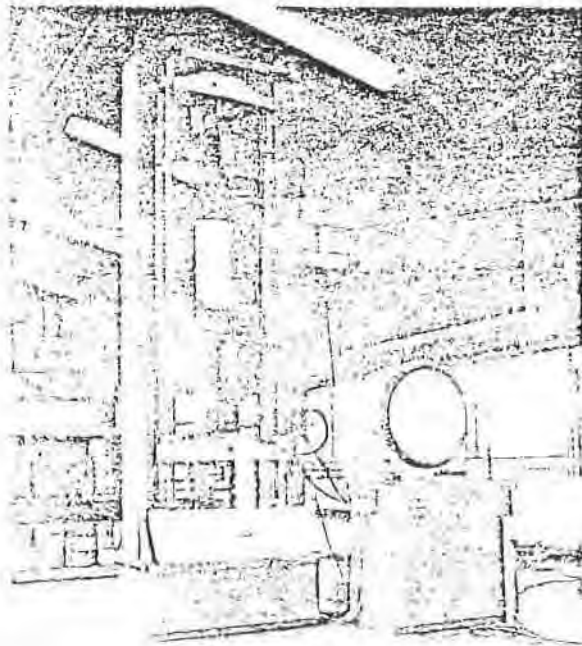

Figure 4 Tension test apparatus

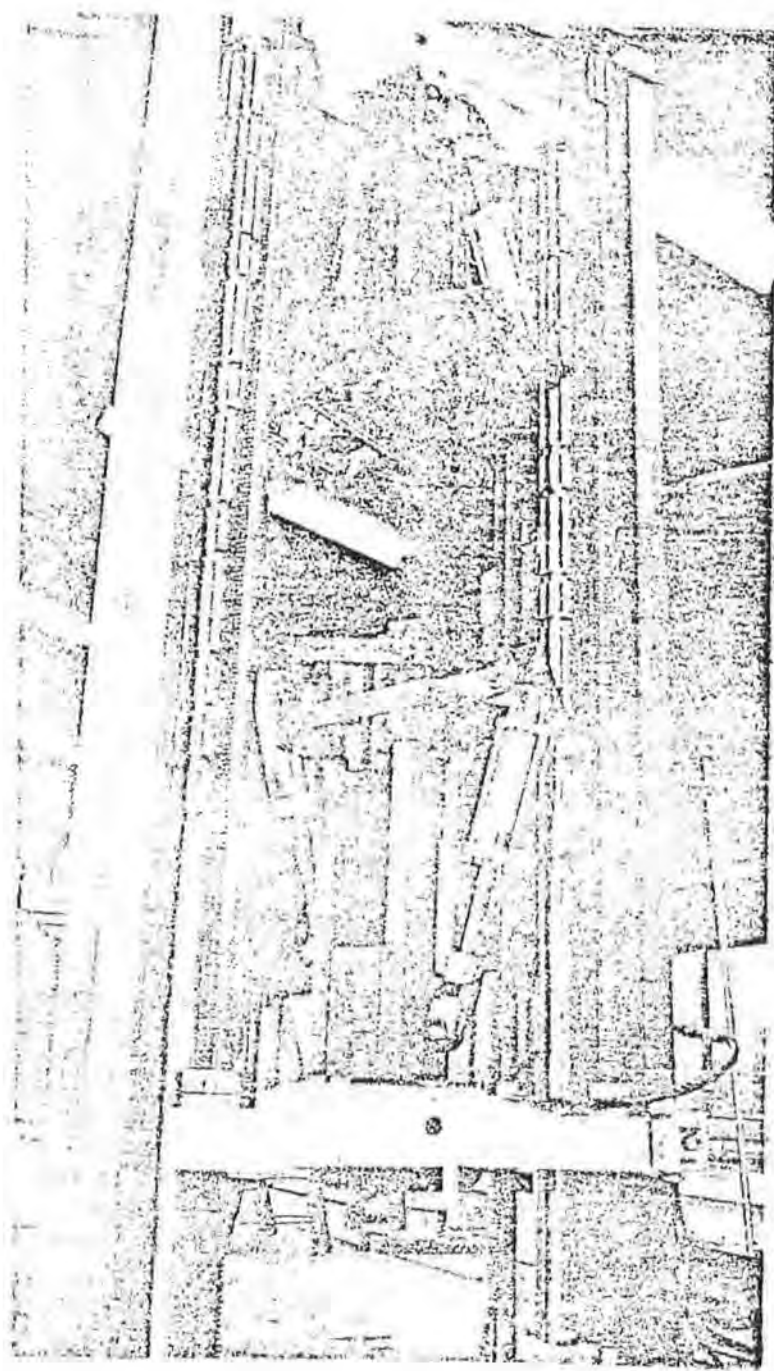
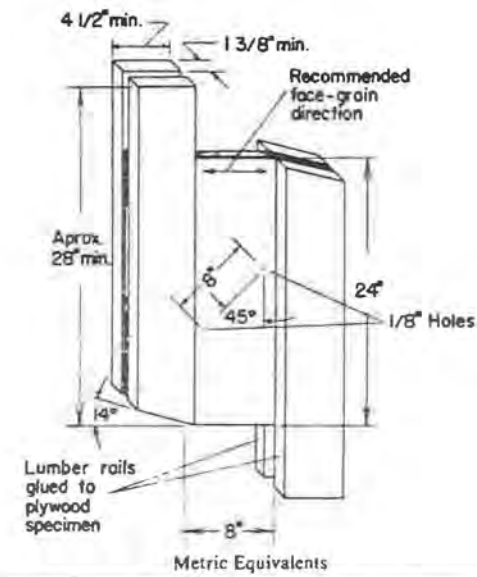

Figure 5 Grips suitable for tension tests



Metric Equivalents

in.	1/8	1 3/8	4 1/2	8	24	28
cm	0.3	3.4	11.4	20	61	71

Figure 6 Details of two-rail shear test specimen

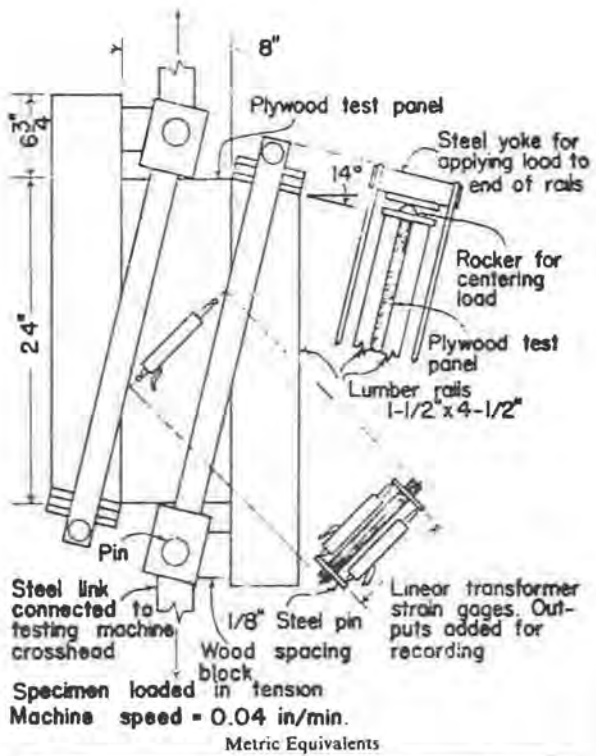

Metric Equivalents

in.	0.04	1/8	1/2	6 3/4	8	24
cm	0.1	0.3	1.3	17	20	61

Figure 7 Loading and strain measuring apparatus for two-rail shear test specimen

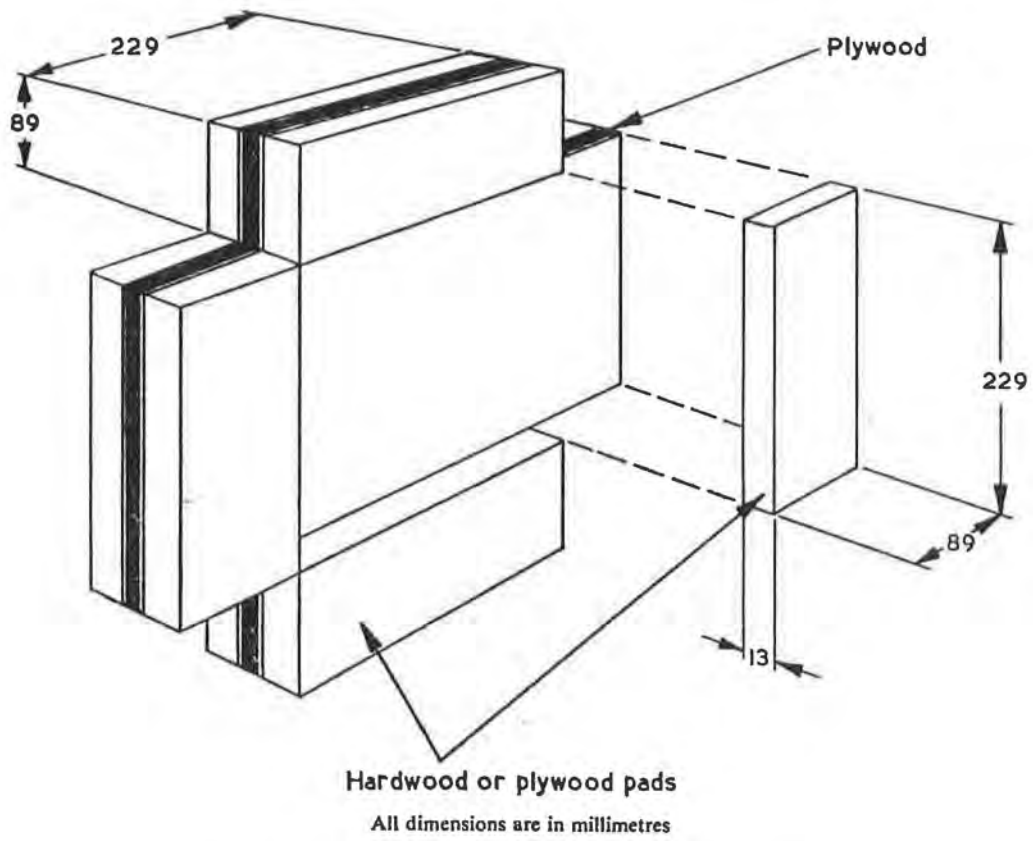

Figure 8 Panel shear specimen

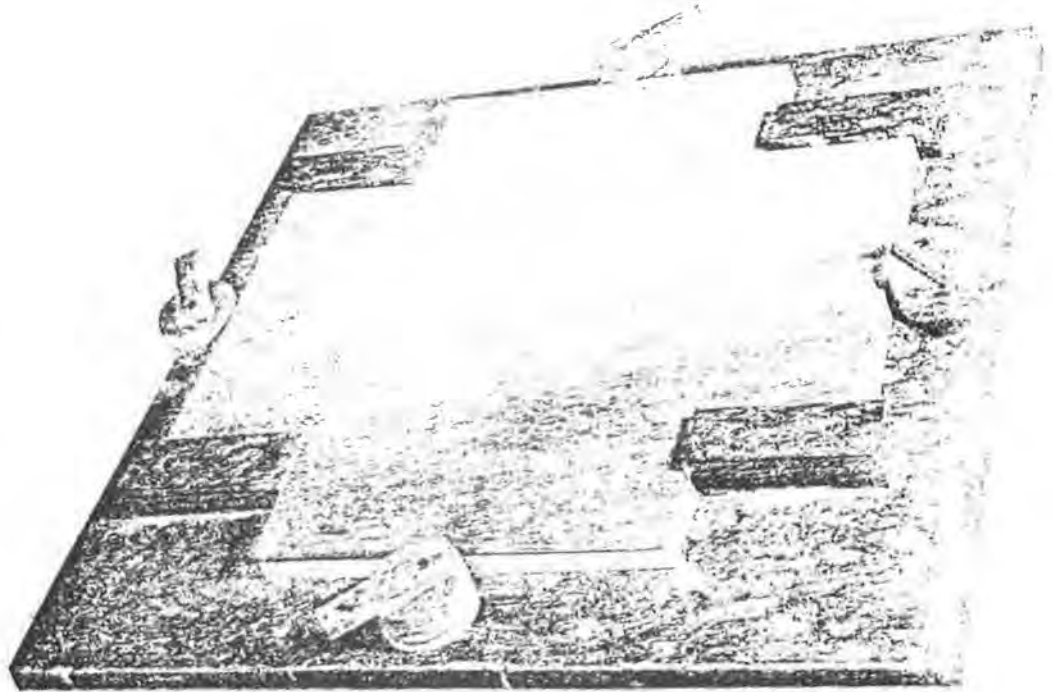
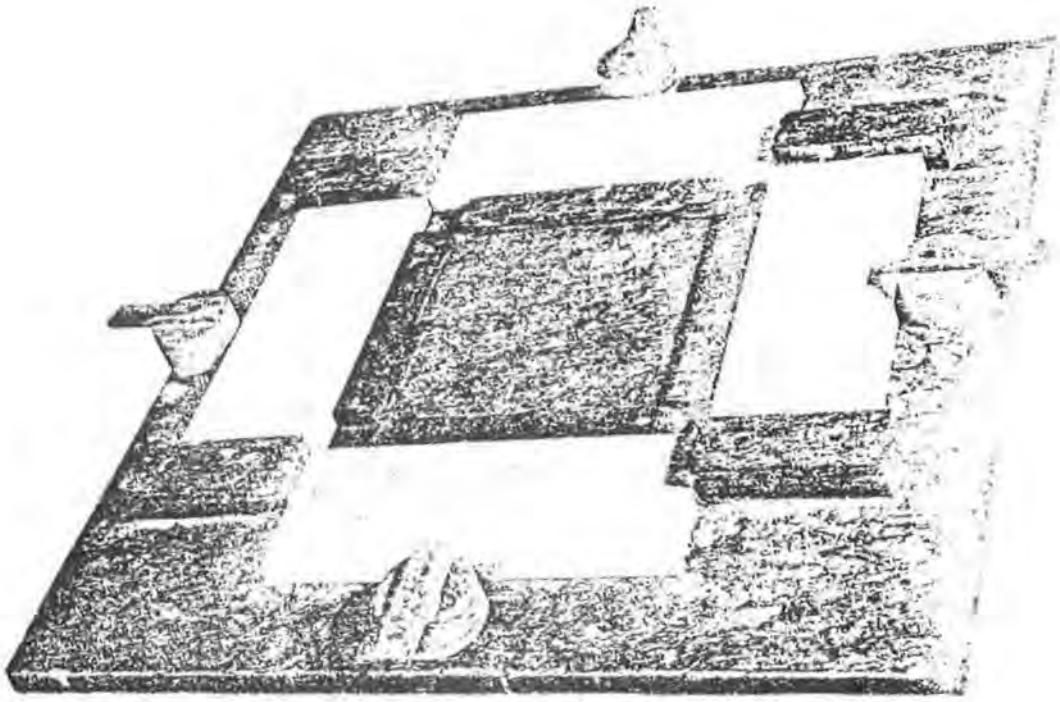

Figure 9 Panel shear jig for assembling panel shear specimens

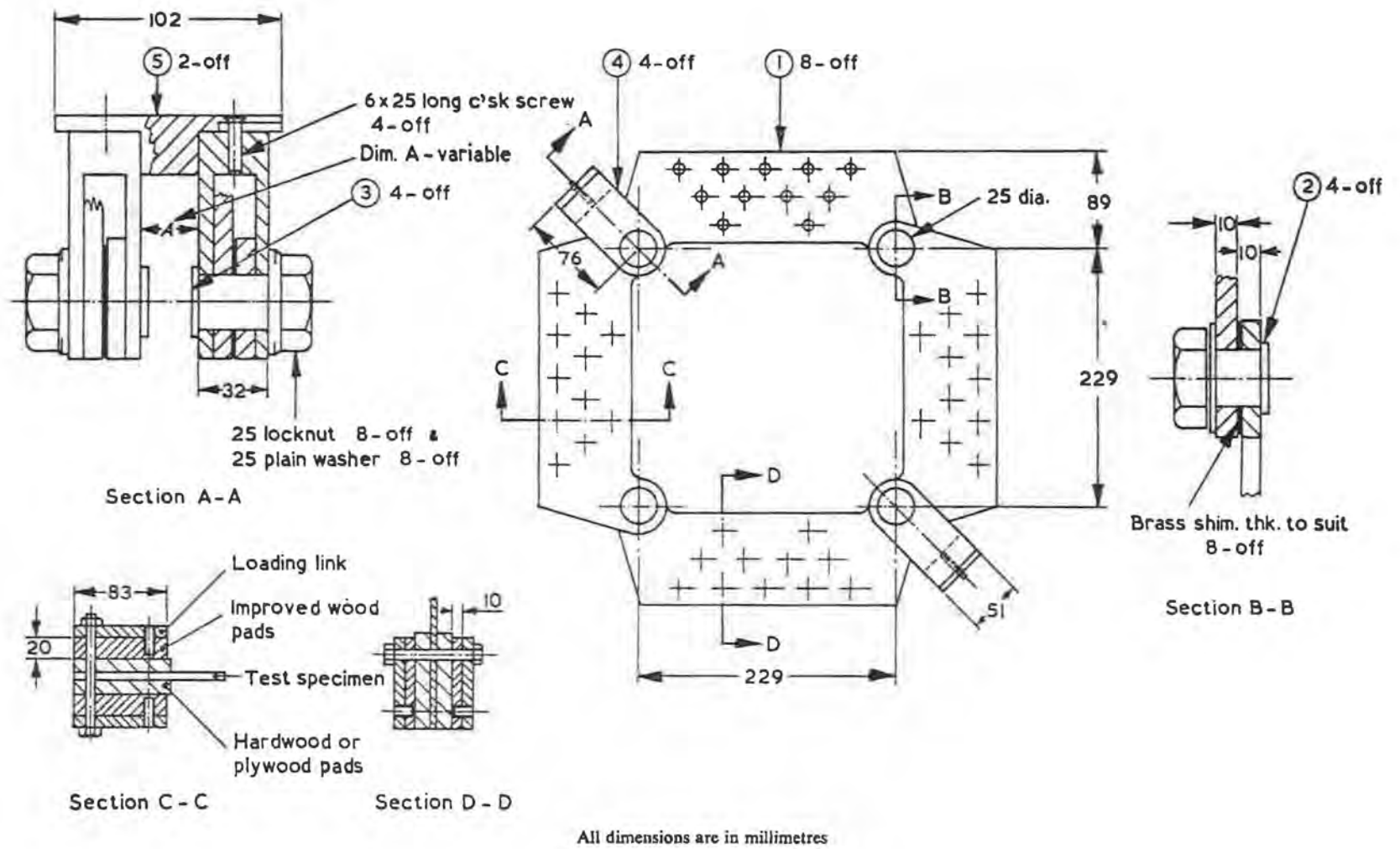

Figure 10 Panel shear apparatus

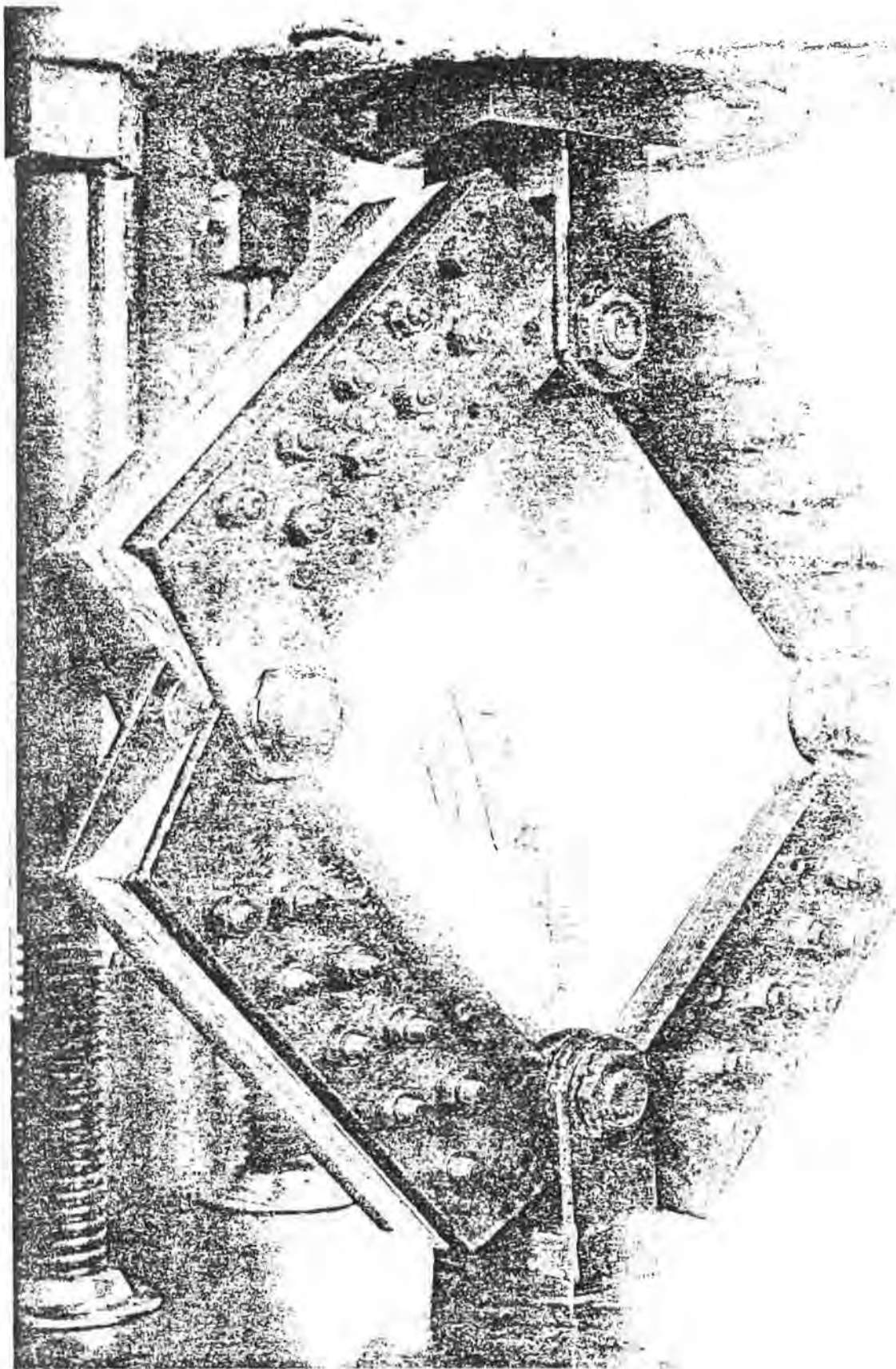

Figure 11 Panel shear test apparatus

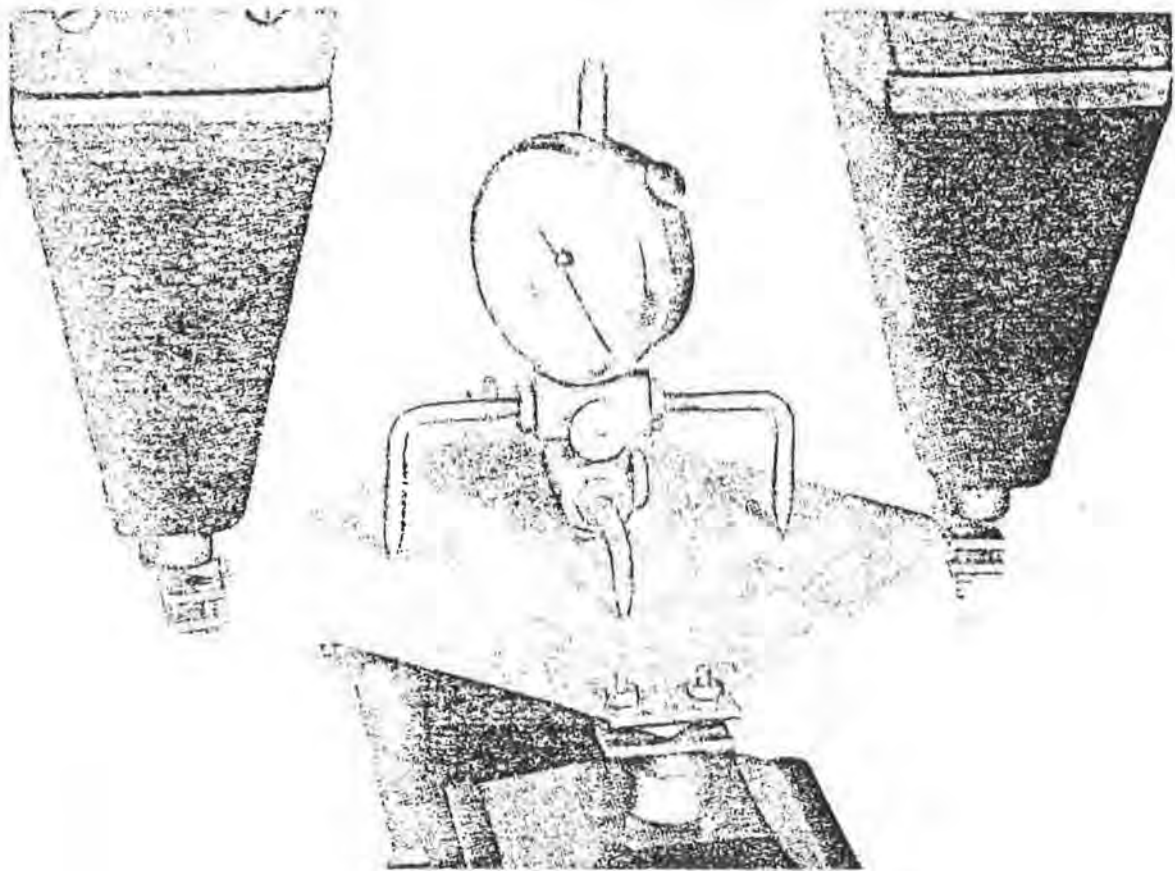
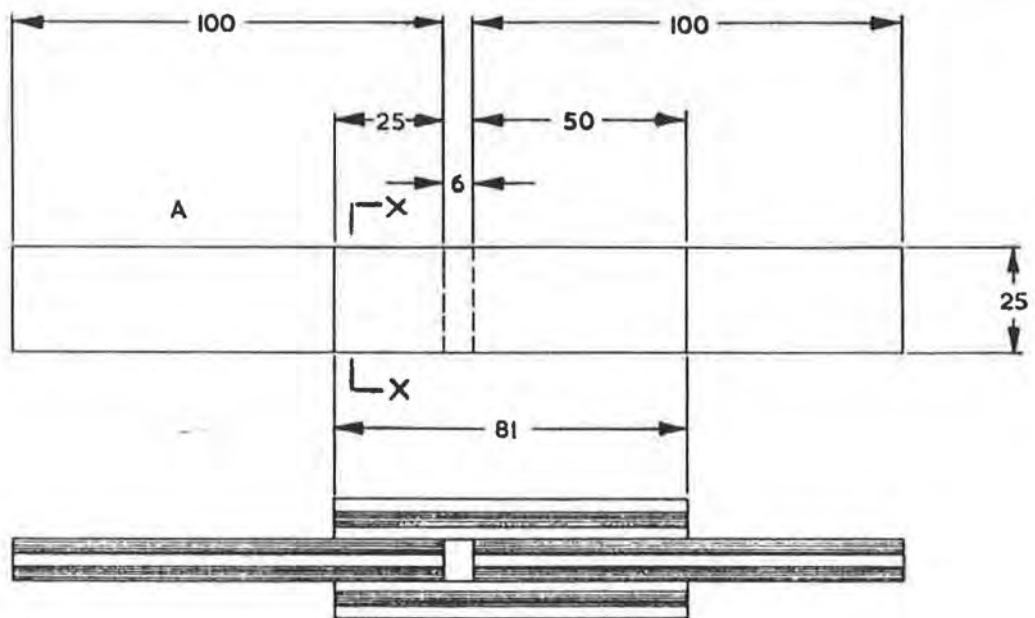



Figure 12 Modulus of rigidity test of plywood showing method of loading and measuring differential deformation along the two diagonals



-  Grain parallel to length
-  Grain perpendicular to length

All dimensions are in millimetres

Figure 13 Rolling shear test specimen

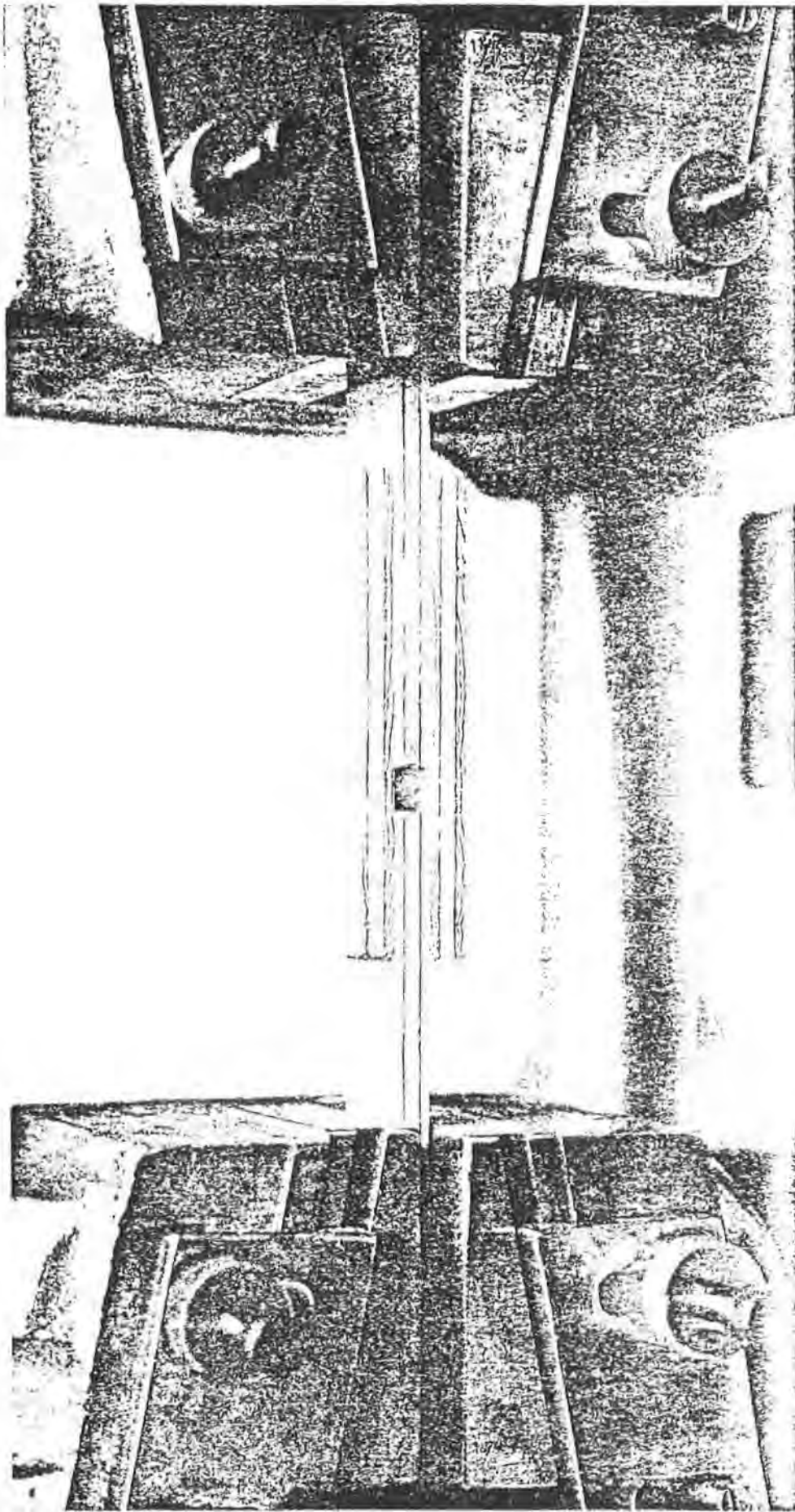

Figure 14 Rolling shear test

INTERNATIONAL COUNCIL FOR BUILDING RESEARCH STUDIES AND DOCUMENTATION  
WORKING COMMISSION W18 - TIMBER STRUCTURES

COMPARISON OF THE SIZE AND TYPE OF SPECIMEN AND TYPE OF TEST  
ON PLYWOOD BENDING STRENGTH AND STIFFNESS

by

C R WILSON, P.Eng  
Council of Forest Industries of British Columbia  
Research and Development Department  
North Vancouver  
BC, Canada

Aalborg, Denmark - June 1976

## COMPARISON OF THE SIZE AND TYPE OF SPECIMEN AND TYPE OF TEST ON PLYWOOD BENDING STRENGTH AND STIFFNESS

C. R. Wilson - Council of Forest Industries of British Columbia,  
Research & Development Department,  
North Vancouver, British Columbia, Canada.

### Background

At recent CIB W.18 meetings (Delft June 1974, Paris February 1975, Karlsruhe October 1975) it has been generally agreed that the size of specimen (small, medium or large), the type of specimen (clear or in-grade), and the type of bending test (centre point of span loading, third point of span loading, pure moment four point loading) influences the magnitudes and variabilities of the test results. To date some work by Booth<sup>(1)</sup> and COFI<sup>(2, 3)</sup> has documented the significance of the differences among the flexural properties resulting from the combined effect of size of specimen, type of specimen, and type of bending test. However, it appears that the available experimental data does not permit a direct comparison to evaluate these effects.

This note provides results of a short indicative test program developed to compare the resulting flexural strength and stiffness properties of Douglas Fir plywood using a centre point of span loading test on small clear specimens to a pure moment four point loading test on large in-grade specimens.

### Objective

To evaluate the effect of the type of test and size of specimen on the flexural strength and stiffness of plywood using "matched" specimens.

### Selection and Preparation of Test Specimens

Four groups of 10 panels (5 ply - 1/2 inch - 1/10 inch plies), manufactured in accordance with CSA Standard O121-1973 Douglas Fir Plywood, were randomly selected from routine mill production. The four groups were selected from two mills at two different periods of time.

Each panel was number coded and cut as shown in Figure 1, "Cutting Plan." Typical specimens tested are shown in Plate 1, "Typical Specimens from a Plywood Panel."

### Test Procedures

Small clear specimen tests were conducted following the requirements of

ASTM D 3043-72 Standard Methods of Testing Plywood in Flexure, Method A, Centre Point Flexure Test for Small, Simply Supported Specimens. (See Plate 2, "ASTM Method A Flexure Test.")

In-grade specimen tests were conducted following the requirements of

ASTM D 3043-72 Standard Methods of Testing Plywood in Flexure, Method C, Pure Moment Test for Large Panels. (See Plate 3, "ASTM Method C Flexure Test.")

For the in-grade specimens the panels were visually evaluated for strength and the "weaker" face of the panel was stressed in tension.

In addition, individual ply thickness measurements, moisture content, and specific gravity tests were determined for each panel.

### Presentation of Test Results

The summary of the modulus of rupture and modulus of elasticity test results are presented in Tables 1, 2 and 3 using the calculation procedure of full cross section theory, parallel ply theory (neglecting the contribution of perpendicular plies in calculating section properties) and the exact theory (including a 5% contribution of perpendicular plies in calculating section properties) respectively. Table 4 lists ratios which were determined to compare the flexural properties of the small clear specimens to the flexural properties of the large in-grade test specimens.

### Discussion of Results

The nature of this test program was to provide an indication of the effect of size and type of specimen and type of test on the flexural properties of modulus of rupture and modulus of elasticity and was not to determine modification factors that require full technical justification. Hence the selected sample size was small and there is no need to discuss the results by relating the results to more comprehensive test programs except to provide some reference to other work to permit reasonable conclusions.

Other separate and non-related comprehensive studies have tested plywood of constructions similar to those tested in this study. For small clear specimens<sup>(4)</sup> it was found that the coefficient of variation for modulus of rupture was significantly smaller than that found in this study (7.4% vs 19.1% - full cross section theory). For large in-grade specimens<sup>(5)</sup> it was found that the coefficient of variation was greater (22% vs 16.5% - full cross section theory). If in fact these relationships of coefficients

of variation for small clear versus in-grade is vice versa to that found in this study the ratio of small clear versus in-grade (Table 4) would be significantly greater for the 5% exclusion value than for the mean. And it can be concluded that the 1.52 ratio (Table 4) is at the lower end of the range expected and indicated by previous tests.

Unfortunately little data is available on the modulus of elasticity derived from small clear specimen tests. However, the modulus of elasticity is much less affected by grade than by modulus of rupture since the stiffness is measured within the linear portion of the load deflection curve. In addition the small clear centre point load test results in an element of shear deflection within the plywood test specimen which does not occur in the in-grade pure moment load test. Hence it can be concluded that the 0.91 ratio (Table 4) is at the lower end of the range expected.

### Conclusions

Based on the results of this indicative test program, and by considering the results of other non-related comprehensive test programs, the following can be concluded:

1. The mean and 5% exclusion value for the flexural property of modulus of rupture is 50% - 60% greater for small clear specimens than for large in-grade specimens. This relationship is at the lower end of the range expected and could be significantly greater, particularly for the 5% exclusion value.

2. The mean and 5% exclusion value for the flexural property of modulus of elasticity is 10% less for small clear specimens than for large in-grade specimens. This can be partially explained by the shear component of stress that occurs using the centre point load test which contains an element of shear deflection. This relationship is at the lower end of the range expected.

## References

1. Booth, L.G., The Determination of Design Stresses for Plywood in the Revision of CP 112, CIB W.18 Karlsruhe Proceedings, October 1975.
2. COFI R&D Department, Standard Methods of Testing for the Determination of Mechanical Properties of Plywood, Paper 5, CIB W.18 Paris Proceedings, February 1975.
3. COFI R&D Department, The Effect of Size and Type of Specimen and of Testing Procedures on the Evaluation of Plywood Bending Strength, January 1976.
4. Parasin, A.V., Bending and Bond Strength Tests of Douglas Fir Plywood and Canadian Softwood Plywood According to German Industrial Standard DIN 68 705, COFI R&D Report 104, June 1974.
5. Barnes, G.W., Flexure Strength Tests of Sheathing Grade Douglas Fir Plywood Phase 2, COFI R&D Report 83, December 1969.

## Acknowledgments

A special thanks is extended to Mr. Alexander Parasin for supervising the overall program and to the COFI R&D staff for carrying out the tests and for calculating the results presented in this technical note.

fig.16. Approximation of calculated boundary for stress combinations by a circle.

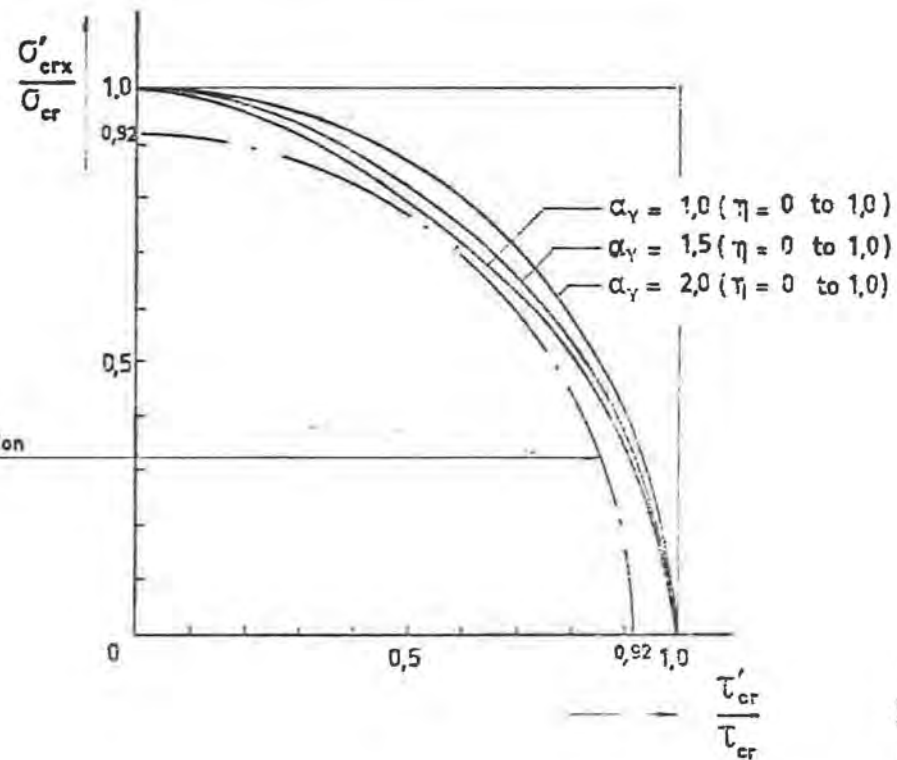
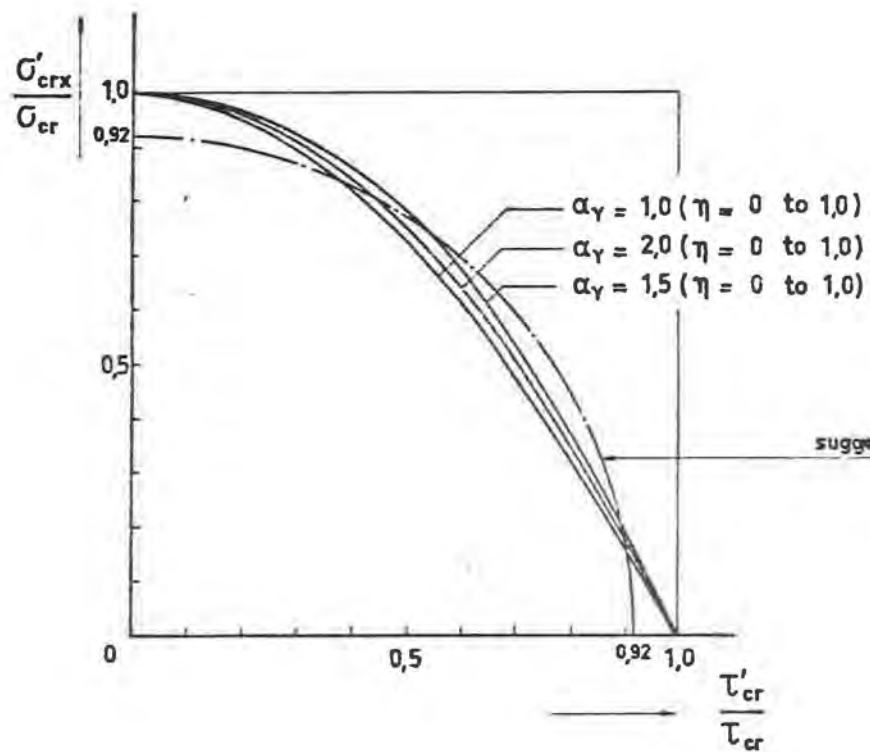
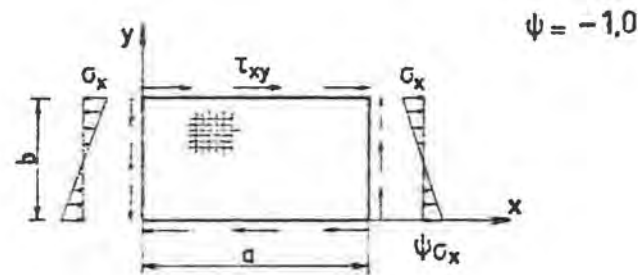
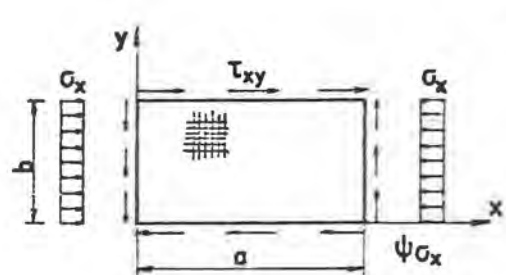

4.1.4. Combination of normal stresses in two directions (uniform distributed)

If again  $\sigma_{crx}^1$  and  $\sigma_{cry}^1$  are used as the symbols for the combined actions and  $\sigma_{crx}$  resp  $\sigma_{cry}$  the critical values if there are only stresses in the X- or in the Y- direc-

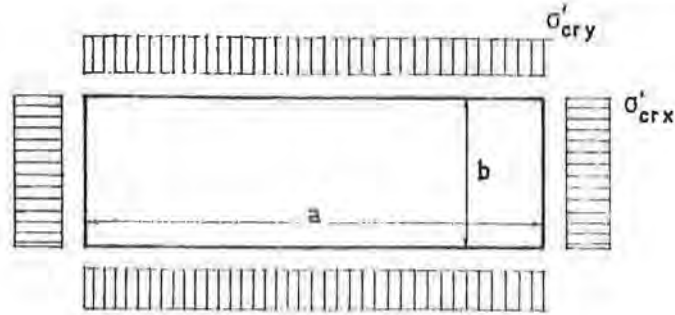

fig.17.

tion, it can be shown [5] that the following relationship holds:

$$\frac{\sigma_{crx}^1}{\sigma_{crx}} + \frac{\sigma_{cry}^1}{\sigma_{cry}} = 1$$

which is a straight line in fig. 18.

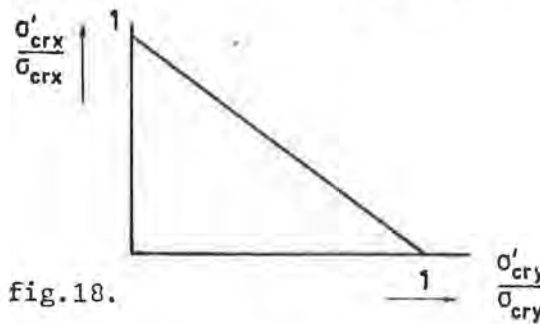

fig.18.

4.1.5. Combination of two normal and shear stresses.

Based upon the relationships in the foregoing it seems not too hazardous to extend the boundaries to a three-dimensional system as fig. 19, which could be

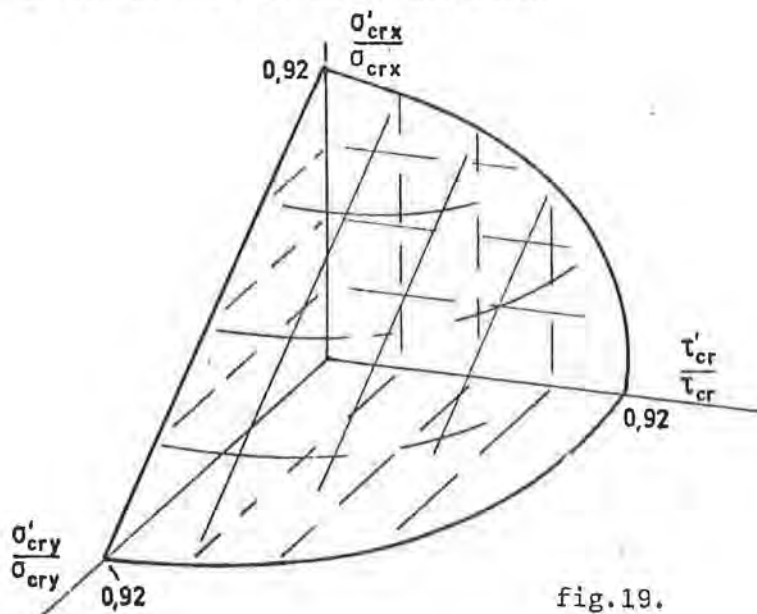

fig.19.

described by

$$\left( \frac{\sigma'_{crx}}{\sigma_{crx}} + \frac{\sigma'_{cry}}{\sigma_{cry}} \right)^2 + \left( \frac{\tau'_{cr}}{\tau_{cr}} \right)^2 = 0,85$$

This three-dimensional figure is only an extrapolation of the three boundaries in the three main planes; there is no verification available as yet.

5. Aspects of safety.

In table 2 values have been given of the ratio  $\varphi$  between the critical loads from the tests (cf fig.7.) and as calculated following data of the TGH (see note page 8). Here only the simple supported plates have been considered.

table 2

b	t	// or $\perp$	$\varphi$	st.dev.	var.c.	n
400	8	//	1,99	0,25	12,4%	5
	8	$\perp$	2,16	0,54	25,2	6
	13	//	1,16	0,15	12,9	8
	13	$\perp$	1,18	0,07	6,3	6
600	8	//	1,49	0,53	35,4	6
	8	$\perp$	1,04	0,15	14,6	3
	13	//	1,09	0,18	16,6	6
	13	$\perp$	1,08	0,09	8,1	4

For the whole sample a "mean" coefficient of variation  $v$  can be calculated according to

$$v = \sqrt{\frac{\sum [(n_i - 1) V_i^2]}{\sum (n_i - 1)}} = 19,3\%$$

As already was known from graphs I and III  $\varphi > 1$ ; a mean value of  $\varphi \approx 1,4$  can be calculated.

Furthermore the failure load reached after the buckling occurred is about 2 times the critical load. This post-buckling effect however is not present if  $\beta$  becomes 1 or less, so in the case of square plates or shorter ones. In those cases the compressive strength limits the load. More "exact" is this the case if

$$\alpha_v = \beta \sqrt{\frac{N_y}{N_x}} \geq 1.$$

On the basis of the foregoing a set of limitations to the stresses can be proposed:

- 1.) the calculated stresses in a plate, resulting from the loads on the structure may not exceed the allowable stresses  $\bar{\sigma}_{compr}$  and  $\bar{\tau}$ .
- 2.) The calculated stresses may not exceed allowable critical stresses  $\bar{\sigma}_{cr}$ ,  $\bar{\tau}_{cr}$  or certain combinations thereof.

With the theory in [6] the values of  $\bar{\sigma}_{cr}$  can be calculated to

$$\bar{\sigma}_{cr} = \frac{\sigma_{cr}}{2,1} = 0,48 \sigma_{cr} \approx 0,7 \sigma_{cr} \text{ test, where no reduction has}$$

been given for long duration of loading.

- 3.) for the effect of permanent loadings it is assumed that a good approximation of the behaviour of the plywood plate under increasing loads, after creep and eventual other effects have taken place may be given by the — — line

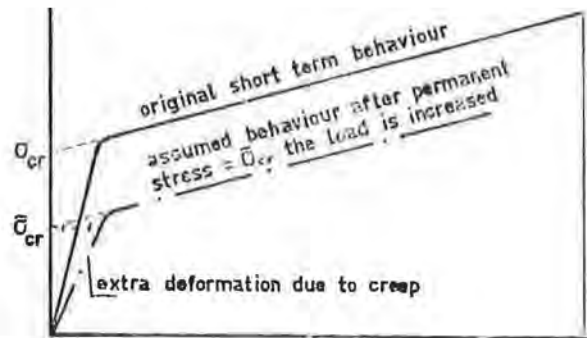

fig.20.

in fig. 20. In this case it is assumed that a real critical buckling stress cannot be given any more, but that the stiffness of the plate which resists the increasing deformations remains the same.

This reasoning leads to the assumption that for permanent loading up to the allowable value a safety factor of roughly 4 ( $\approx 3 \times 1,4$ ) exists with respect to the post buckling strength.

In the case of stress combinations the calculated stresses  $\sigma'_x, \tau'_y$  and  $\tau'$  must fulfill the equation

$$\left( \frac{\sigma'_x}{\sigma_{crx}} + \frac{\sigma'_y}{\sigma_{cry}} \right)^2 + \left( \frac{\tau'}{\tau_{cr}} \right)^2 \leq 0,85$$

Based on the foregoing the calculation control of plywood as a structural material in load-bearing structures can be effected. For practical purposes sets of calculated values for different plywoods and for certain loading conditions can be given. Experience and further research may give way to lower safety factors in the future.

Literature

- [1] Timoshenko & Gere "Theory of elastic stability".  
Mc Graw. Hill Book Comp. inc.
- [2] S.G. Leknitskii "Anisotropic Plates".  
Gordon and Breach Science Publishers.
- [3] R. v. Halasz und E. Cziesielski "Berechnung und Konstruktion geleimter  
Träger mit Stegen aus Furnierplatten". Berichte aus der Bauforschung  
Heft 47. Wilhelm Ernst & Sohn.
- [4] J.N. Dekker "Plooigedrag van Canadees Oregon pine triplex // en  $\perp$  de vezel-  
richting van de dekfinerlaag". Rapport 4-73-16-T13 Stevinlaboratorium Delft.
- [5] H. Ploos van Amstel "De berekening van het instabiliteitsgedrag van triplex  
in constructies; voorstellen voor richtlijnen".  
Rapport 4-75-1, TC 34, Stevinlaboratorium Delft.
- [6] J. Kuipers "Structural Safety". Heron; English edition n° 5 (1968), Delft.
- [7] Anon. Tabellen en grafieken voor Houtconstr. T G H. publ. Houtvoorlichtings-  
inst. HVI A'dam.

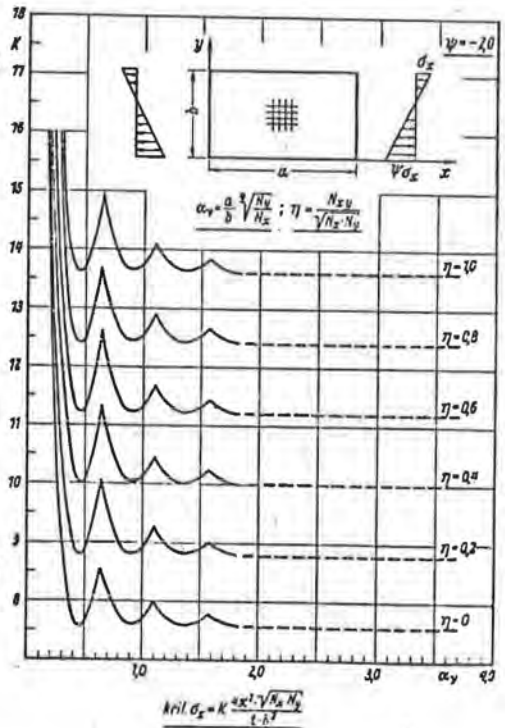
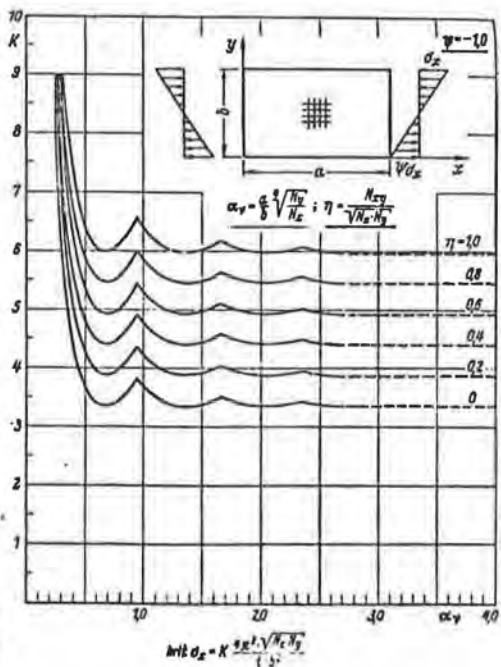
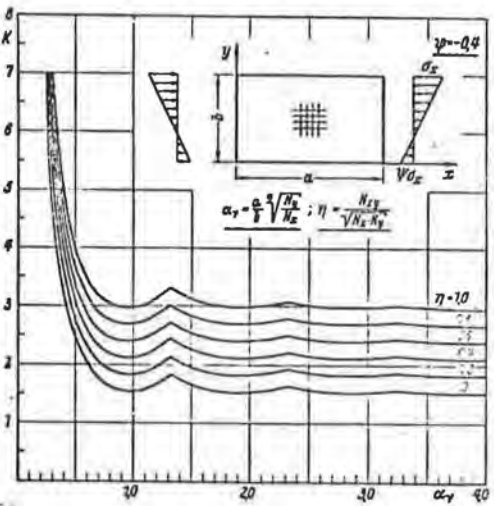
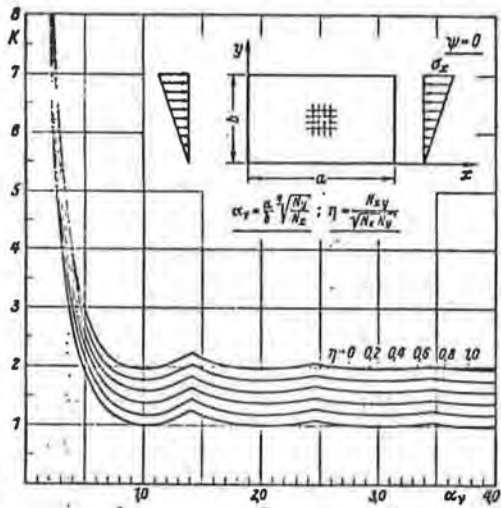
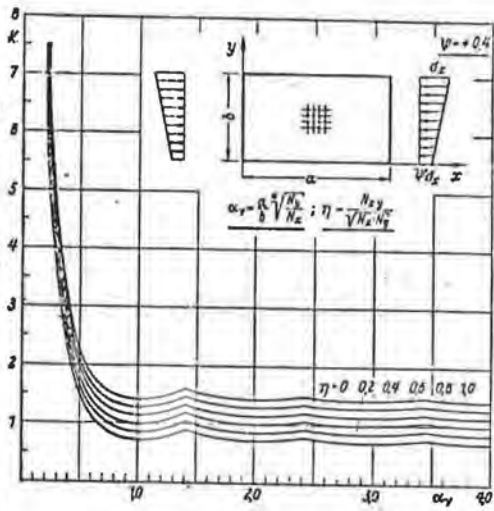
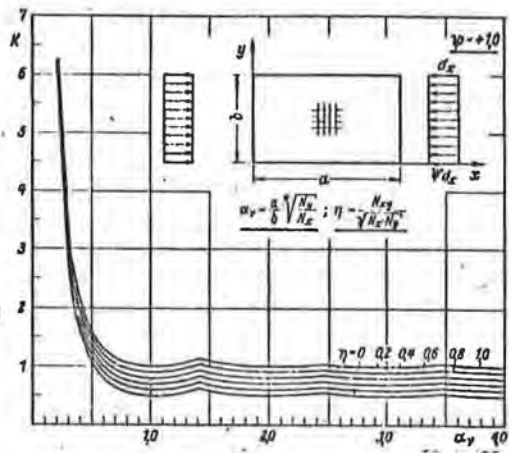

graph I

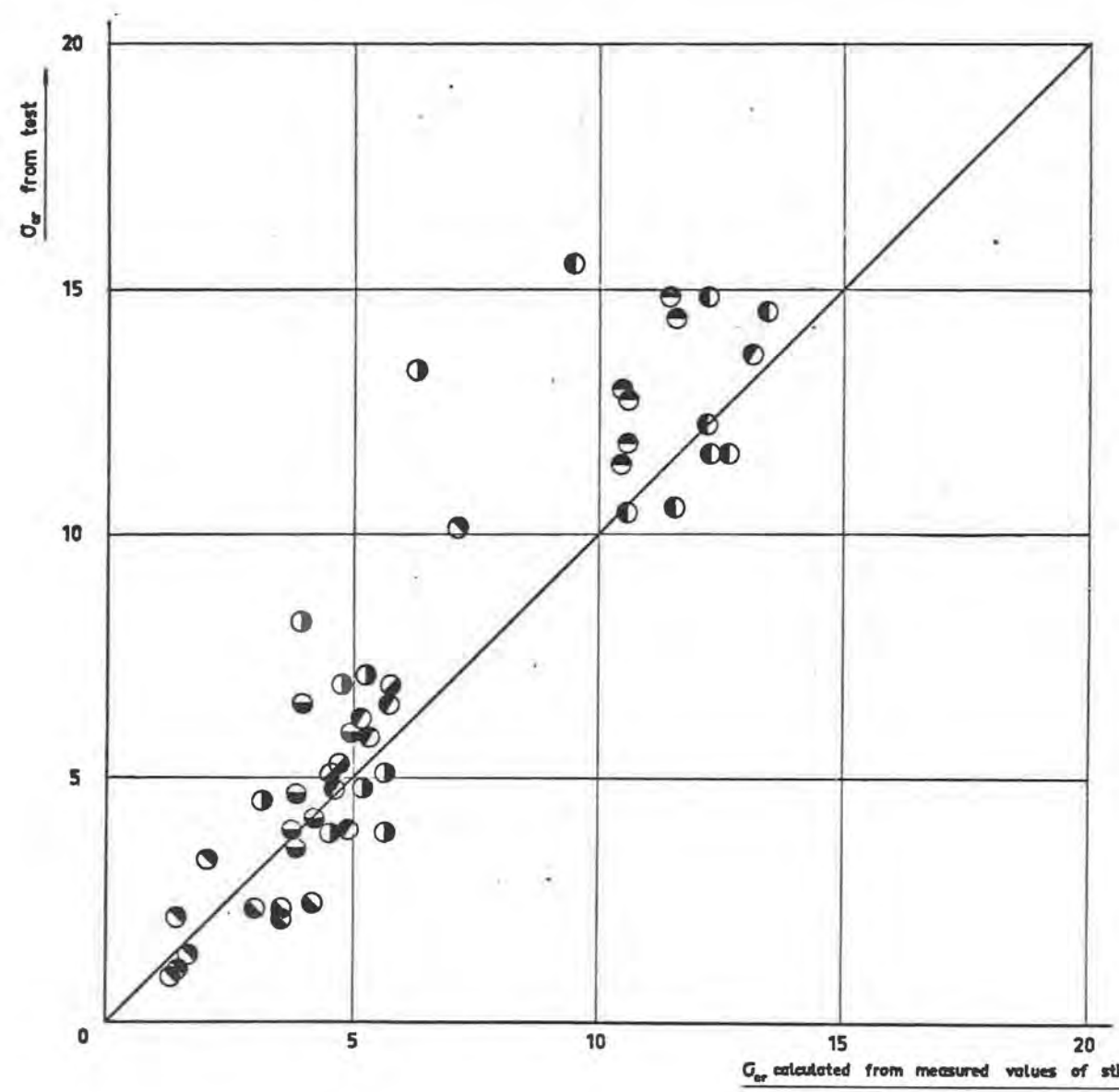

simply supported

	thickness	direction of load to face grain	
width 40	8 mm	//	●
	8 mm	⊥	◐
	13 mm	//	◑
	13 mm	⊥	◒
width 60	8 mm	//	◑
	8 mm	⊥	◒
	13 mm	//	◐
	13 mm	⊥	◑

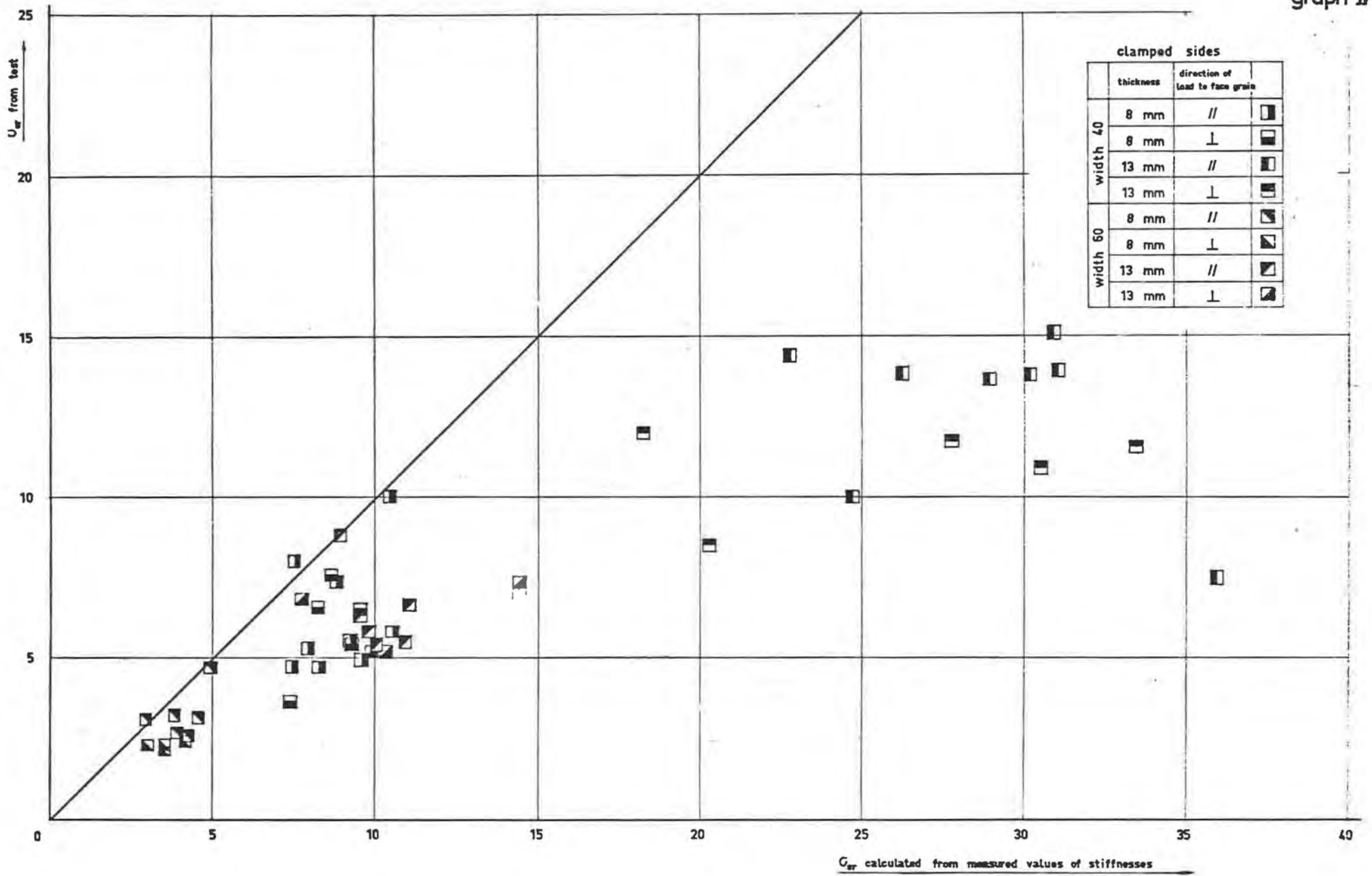

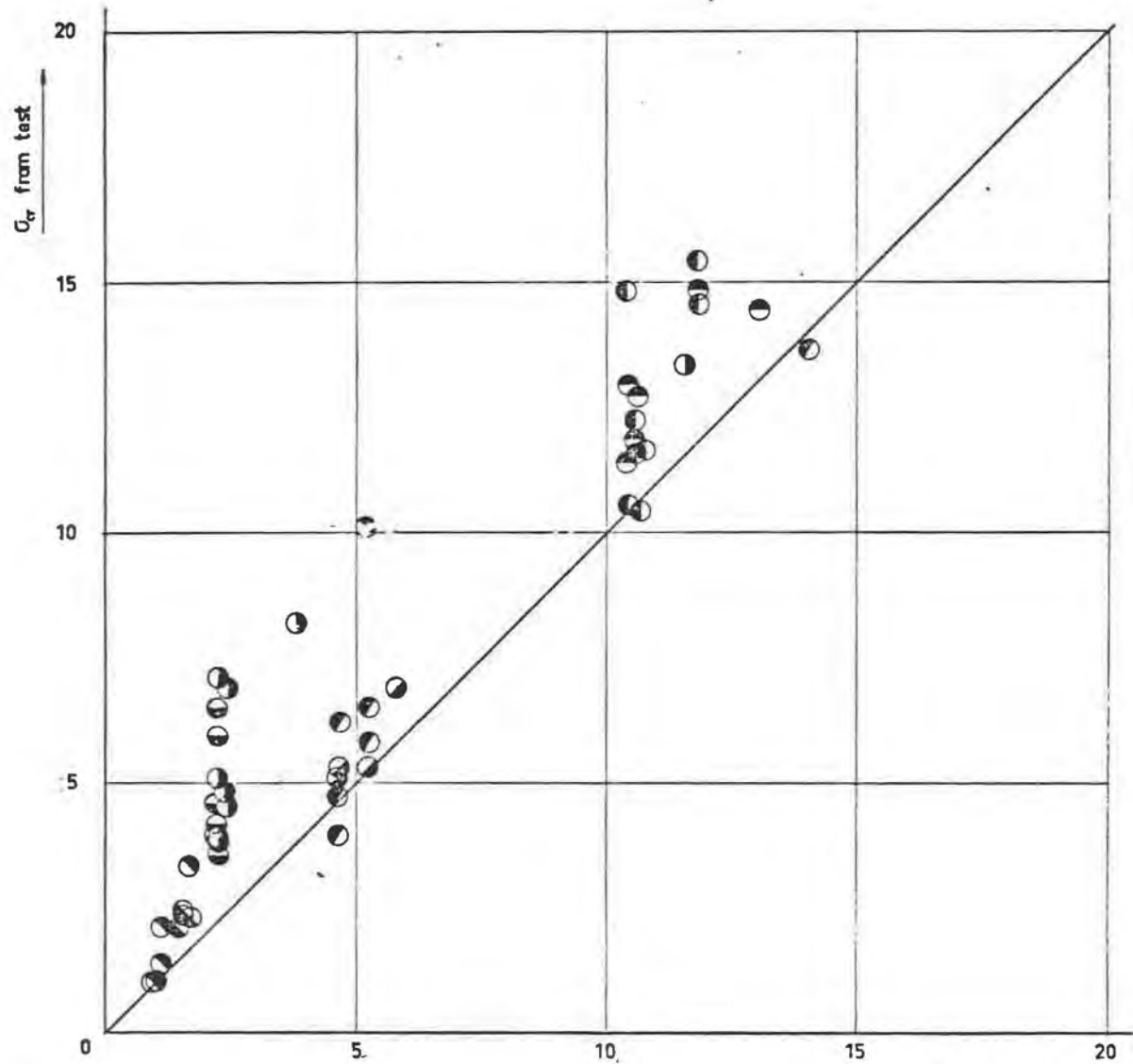

	thickness	direction of load to face grain	
width 40	8 mm	//	●
	8 mm	⊥	●
	13 mm	//	●
	13 mm	⊥	●
width 60	8 mm	//	●
	8 mm	⊥	●
	13 mm	//	●
	13 mm	⊥	●

$\sigma_{cr}$  calculated on the basis of data from T.G.H. [7]

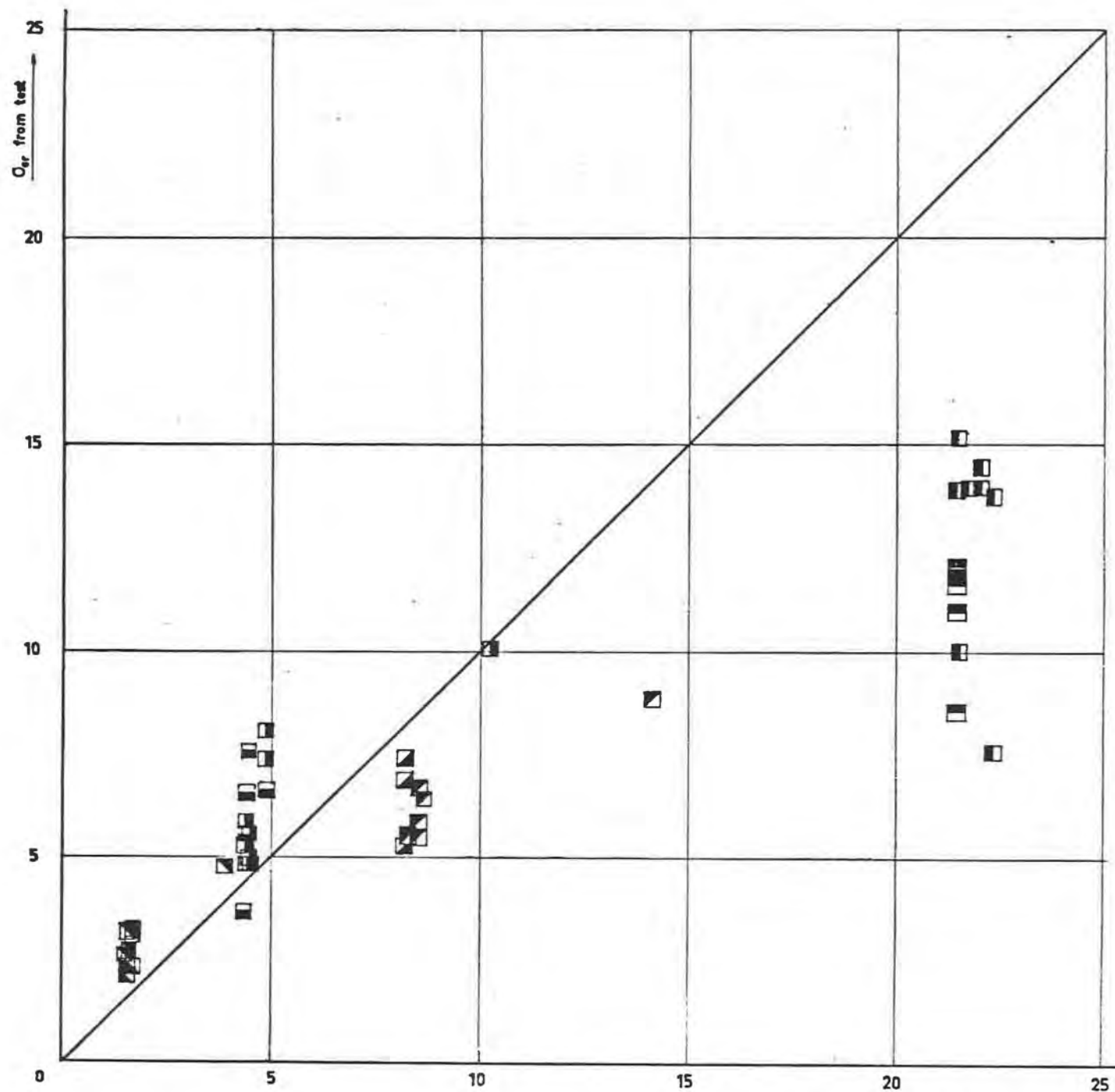

clamped sides			
	thickness	direction of load to face grain	
width 40	8 mm	//	
	8 mm	⊥	
	13 mm	//	
	13 mm	⊥	
width 60	8 mm	//	
	8 mm	⊥	
	13 mm	//	
	13 mm	⊥	

$O_{cr}$  calculated on the basis of data from T.G.H. 17

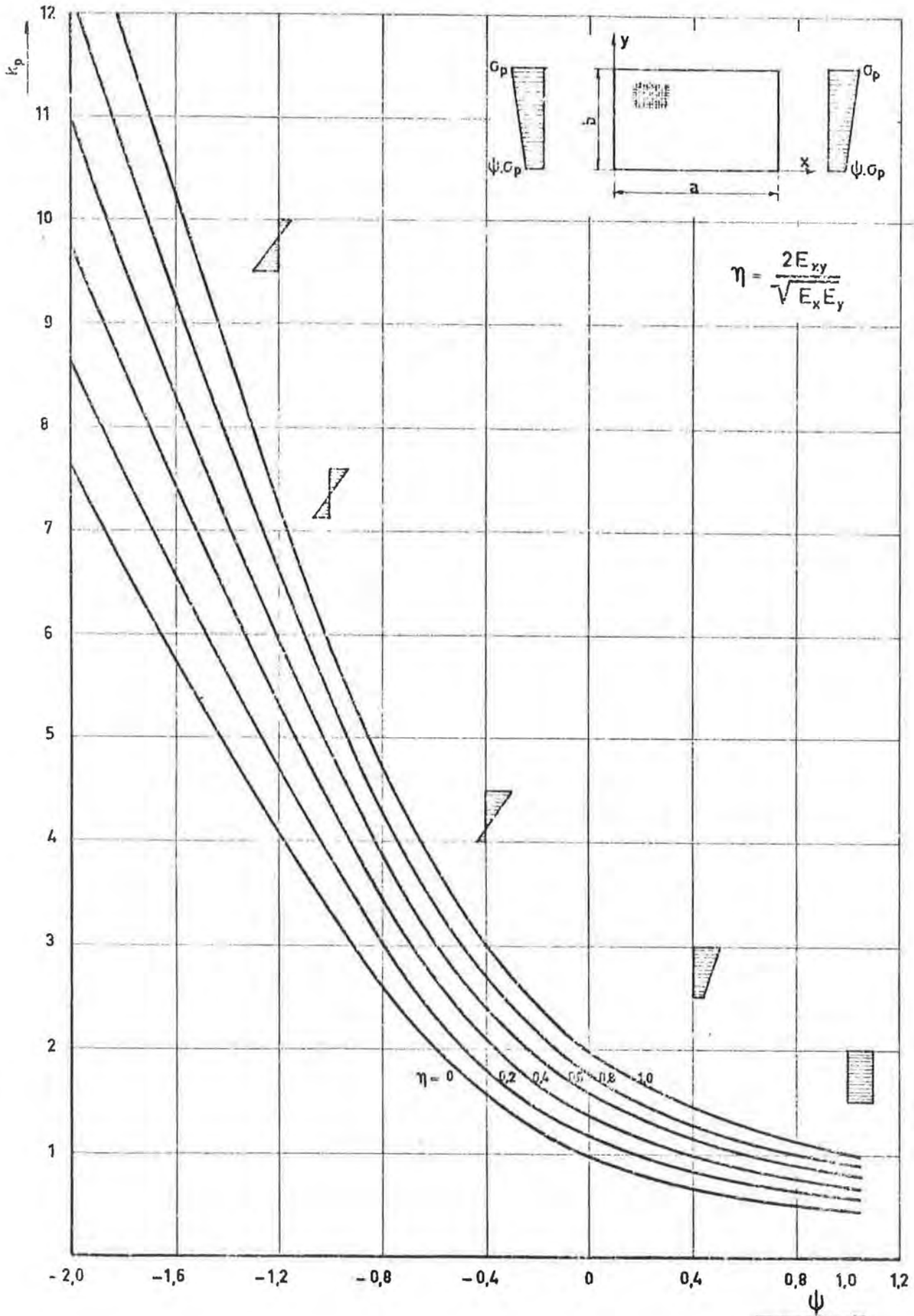

graph VI

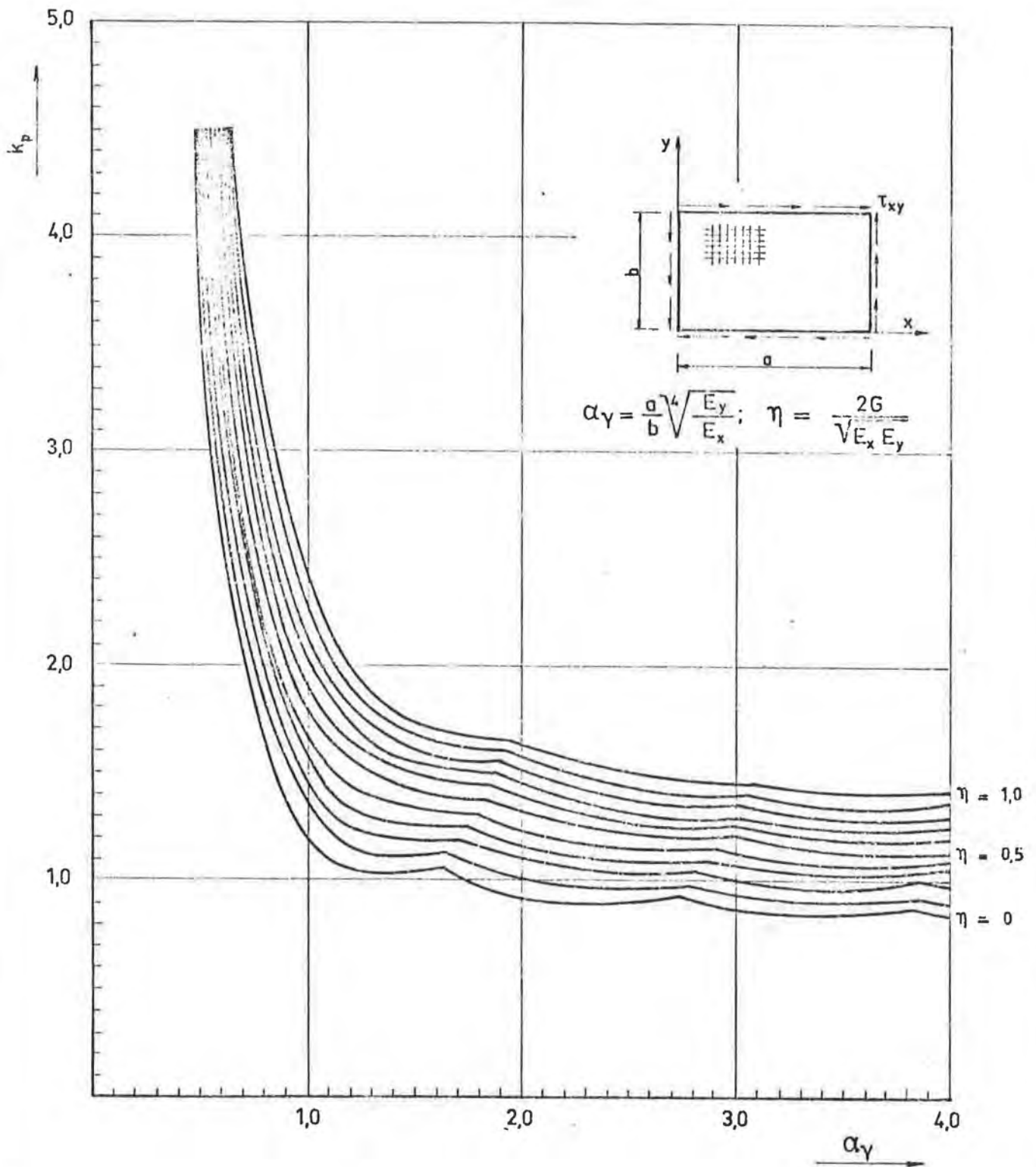

graph VII

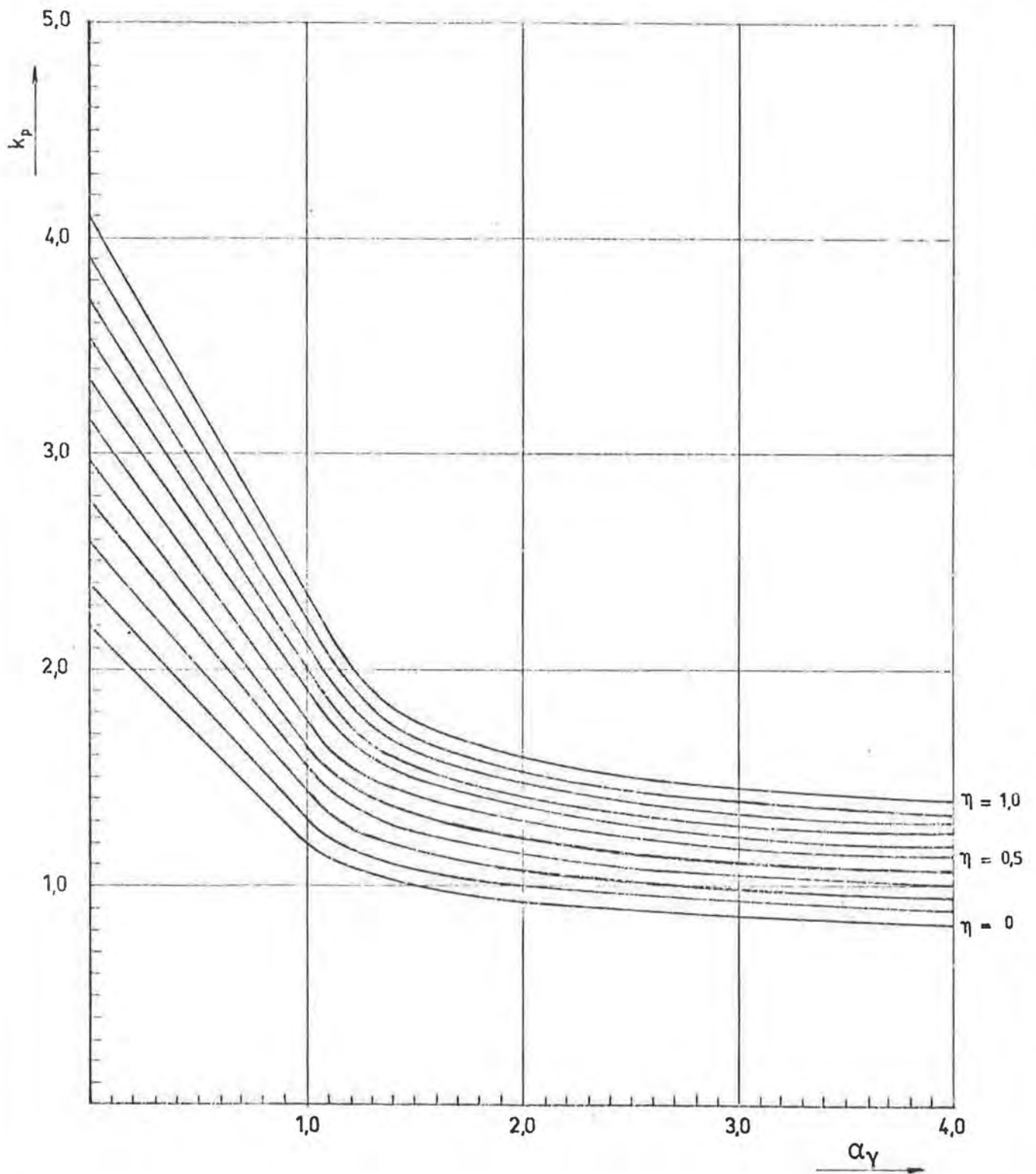

INTERNATIONAL COUNCIL FOR BUILDING RESEARCH STUDIES AND DOCUMENTATION  
WORKING COMMISSION W18 - TIMBER STRUCTURES

STANDARD METHODS OF TEST FOR THE DETERMINATION OF SOME PHYSICAL  
AND MECHANICAL PROPERTIES OF TIMBER IN STRUCTURAL SIZES  
(THIRD DRAFT)

by

W T CURRY  
Building Research Establishment  
Princes Risborough Laboratory  
United Kingdom

Aalborg, Denmark - June 1976

STANDARD METHODS OF TEST FOR THE DETERMINATION OF SOME PHYSICAL  
AND MECHANICAL PROPERTIES OF TIMBER IN STRUCTURAL SIZES

FOREWORD

This document was prepared at the request of the W18 - Timber Structures - Commission of CIB which recognised the need to establish standard methods of test to permit the correlation, and consequently a much wider use of test data from various sources. After consideration of a first draft by a sub-committee of W18 a second draft was produced and submitted for discussion at a general meeting of the Commission in Karlsruhe, October 1975. This third draft incorporates the recommendations made at this second meeting.

## CONTENTS

- 1 Introduction
- 2 Scope
- 3 Symbols
- 4 Sampling and Specimen Selection
  - 4.1 Sampling
  - 4.2 Specimen Selection
- 5 Physical tests
  - 5.1 Identification
  - 5.2 Dimensions
  - 5.3 Moisture content
  - 5.4 Density
    - 5.4.1 Gross relative density
    - 5.4.2 Nominal relative density
    - 5.4.3 Relative density
- 6 Grade Determining Properties
  - 6.1 Visual
    - 6.1.1 General
    - 6.1.2 Knots
  - 6.2 Mechanical
    - 6.2.1 General
    - 6.2.2 Modulus of elasticity
- 7 Strength Tests
  - 7.1 Bending
    - 7.1.1 Modulus of elasticity
    - 7.1.2 Shear modulus
    - 7.1.3 Ultimate bending strength
  - 7.2 Tension
    - 7.2.1 Modulus of elasticity

7.2.2 Ultimate tension strength

7.3 Compression

7.3.1 Modulus of elasticity

7.3.2 Ultimate compression strength

# STANDARD METHODS OF TEST FOR THE DETERMINATION OF SOME PHYSICAL AND MECHANICAL PROPERTIES OF TIMBER IN STRUCTURAL SIZES

## 1 INTRODUCTION

This standard gives preferred methods of test for the determination of the principal physical and mechanical properties of structural timber. It is recommended that they should be adopted wherever possible to ensure comparable data between countries and research centres and to enhance the use that can be made of accumulated data. For some of the properties alternative methods of defining or measuring them are given. All are equally acceptable and the choice of which to use will depend upon the objectives of any test programme and possibly on the equipment available.

Because of the cost of testing timber in structural sizes consideration should be given to the establishment of a data bank on strength properties and growth characteristics, even where this would involve recording information in addition to that which is essential to a particular project. With the use of computers, data storage, transmission and access are greatly simplified and with little extra effort individual projects could provide information of value in the future, in broader areas of research such as:

- visual and machine stress grading
- harmonisation of stress grading
- determination of characteristic strength values
- monitoring the quality of structural timbers
- determination of the effects of moisture content, load duration, size etc.

## 2 SCOPE

This standard specifies methods of test for determining some physical and mechanical properties of timber in structural sizes. Although the methods apply specifically to solid rectangular or square sections of timber some of them could also be applied to other sections, and to laminated timber. The physical properties are:

- dimensions
- moisture content
- density

and the mechanical properties are:

- modulus
- methods of elasticity in bending
- shear modulus
- ultimate bending strength parallel to grain
- modulus of elasticity in tension
- ultimate tension strength parallel to grain
- modulus of elasticity in compression
- ultimate compression strength parallel to grain

Reference is also made to sampling and to the selection of test specimens but it is recognised that the methods employed must be decided upon from a consideration of the objectives of an investigation.

### 3 SYMBOLS

- A area of section,  $\text{mm}^2$
- a the distance between an inner load point and nearest support in bending, mm
- $D_{g\omega}$  the average or gross relative density of a complete specimen at a moisture content  $\omega$
- $D_{m0}$  nominal relative density, volume at moisture content  $\omega$  and mass at  $\omega = 0$
- $D_{00}$  relative density, volume and mass at  $\omega = 0$
- E modulus of elasticity,  $\text{N/mm}^2$
- $E_a$  apparent modulus of elasticity determined from bending test and including shear deflection,  $\text{N/mm}^2$
- G shear modulus,  $\text{N/mm}^2$
- h section depth in bending, mm
- I second moment of area,  $\text{mm}^4$
- l full span in bending and specimen test length in tension and compression, mm
- $l_1$  gauge length, mm
- P increment of load, N
- $P^1$  maximum load, N
- R rate of movement of testing machine cross-head, mm/min
- W section modulus,  $\text{mm}^3$
- $\dot{\epsilon}$  rate of straining, per min
- $\delta$  deflection or deformation under an increment of load, mm
- $\sigma_b$  bending stress,  $\text{N/mm}^2$
- $\sigma_c$  compressive stress,  $\text{N/mm}^2$
- $\sigma_t$  tension stress,  $\text{N/mm}^2$
- $\omega$  moisture content, per cent

## 4 SAMPLING AND SPECIMEN SELECTION

### 4.1 Sampling

The material from which the test specimens are obtained should be selected at random, or in accordance with some defined method, to adequately represent the characteristics or attributes associated with the objectives of the investigation.

### 4.2 Specimen Selection

No specific recommendations can be made as to how individual specimens should be selected. Generally each specimen should have its critical section, ie the weakest section as judged by visual inspection, or as indicated by a non-destructive measurement of an indicating parameter (for example modulus of elasticity in machine grading) at the centre of its length. A sufficient number of specimens should be tested to permit the use of mathematical statistics and the achievement of an acceptable confidence in the interpretation of the results.

## 5 PHYSICAL TESTS

### 5.1 Identification

Each specimen shall as necessary be identified for:

- a species
- b normal size
- c country, region or mill of origin
- d grade or any relevant pre-selection
- e other relevant information, eg drying history
- f project reference
- g date of tests

### 5.2 Dimensions

The width (mm) thickness (mm) and length (m) of each specimen shall be determined to three significant figures. Where width or thickness are likely to vary, these dimensions shall be taken as the average of three measurements at different locations throughout the length of the specimen. The moisture content of the specimen at the time of measurement shall be recorded. This will normally be when the specimen is at the condition required for the strength tests.

### 5.3 Moisture Content

Unless otherwise required each specimen prior to preparation and test shall be conditioned to equilibrium moisture content in air at a temperature and relative humidity corresponding to the desired exposure condition. Kiln drying may be used to accelerate drying prior to final stabilisation at the desired exposure condition. Although the equilibrium moisture

content attained under the same exposure conditions will differ somewhat between species, the following relations between moisture content and the relative humidity of air at a temperature of 18°C may be used as a guide when exposure conditions are expressed as moisture contents.

Moisture Content %	Relative Humidity % (air at 18°C)
12	65
15	77
18	83
20	88

When tests are required at the wet condition, ie at a moisture content above the fibre saturation point, this may be obtained by submerging the samples in water or by pressure impregnation. Before specimens are prepared and tested the actual moisture content throughout sample cross-sections should be checked to ensure that the treatment is producing specimens with moisture contents above the fibre saturation point. It is desirable also that wet strength should be determined using specimens which have undergone at least one cycle of drying and re-wetting.

The moisture content of each specimen shall be determined from a cross-section disc, free from knots, and taken close to the fracture in an ultimate strength test, or otherwise not nearer than 300 mm to an end of the specimen. The disc shall have the full cross-section dimensions of the specimen and shall have a length along the grain of  $25 \pm 5$  mm. The full size disc, or where it is desirable to check the moisture content distribution within the section lateral sub-divisions of the disc, shall be immediately weighed to obtain  $m_1$  (g). They shall then be dried to constant mass  $m_0$  (g) in air at a temperature of  $103 \pm 2^\circ\text{C}$ , constant mass being reached when the loss in mass after cooling and between two successive weighings, carried out at an interval of not less than six hours, is not greater than 0.5 per cent. Moisture content shall be calculated as:

$$\omega = 100 (m_1 - m_0) / m_0 \text{ per cent.}$$

Moisture content shall be recorded to the nearest one per cent and any other relevant aspect of the moisture history of a specimen, eg kiln-dried, re-wetted etc shall also be recorded.

#### 5.4 Density

Density can be determined in a number of ways and the most appropriate will depend on the objectives of an investigation. Thus for the determination of the self weight of timber structural members gross relative density is required and for studies of the influence of defects on strength and for comparing samples, relative density or nominal relative density would be more appropriate.

5.4.1 Gross relative density. Gross relative density shall be determined as follows and shall be recorded to three significant figures.

$$D_{g\omega} = m_{\omega} / m_{V\omega}$$

where  $m_{\omega}$  is the mass (g) of the full specimen at moisture content  $\omega$

and  $m_{V\omega}$  is the mass (g) of a volume of water equal to the volume ( $\text{cm}^3$ ) of the full specimen at moisture content  $\omega$ .

5.4.2 Nominal relative density. Nominal relative density shall be determined as follows and shall be recorded to three significant figures.

$$D_{n\omega} = m_o / m_{V\omega}$$

where  $m_o$  is the constant mass (g) after drying (Clause 4.3) of a cross-section disc free from knots and taken close to the fracture in an ultimate strength test, or otherwise not nearer than 300 mm to an end of the specimen,

and  $m_{V\omega}$  is the mass (g) of a volume of water equal to the volume ( $\text{cm}^3$ ) of the disc at moisture content  $\omega$ .

5.4.3 Relative density. Relative density shall be determined as follows and shall be recorded to three significant figures.

$$D_{o\omega} = m_o / m_{V\omega}$$

where  $m_o$  is defined in 4.4.2

and  $m_{V\omega}$  is the mass (g) of a volume of water equal to the volume ( $\text{cm}^3$ ) of the disc after drying (Clause 4.3)

## 6 GRADE DETERMINING PROPERTIES

### 6.1 Visual

It will be sufficient in many investigations simply to record the grade of each specimen in accordance with established grading rules. However, if the magnitude of the growth characteristics and defects present in a test specimen are recorded then the test results will have wider application.

6.1.1 General Properties. The slope of grain, rate of growth, fissures and wane shall be determined for each specimen according to the methods given in ECE Standard "Stress Grading of Coniferous Sawn Timber". The value of each at the critical section shall be recorded, and if the specimen contains the pith this shall also be recorded.

6.1.2 Knots. Knots present at the critical section, or at the fracture section in an ultimate strength test if this is different, shall be recorded by numerical code so that their magnitude, slope and location can be determined. One method of doing this is illustrated in Figure 1.

### 6.2 Mechanical

With non-destructive test methods of stress grading, ie machine grading, grades are established by deciding to what boundary value of the indicating parameter a machine should be set to achieve a selection of timber having

some specified characteristic strength values. Thus the indicating parameter has the same significance for machine grading as do the visible growth characteristics for visual grading, and if these are recorded then the test results will have wider application.

6.2.1 General. Extension of the scope of machine stress grading depends on establishing by laboratory tests the relations between the ultimate strength properties of timber and an indicating parameter, such as deflection, wave velocity, vibration frequency and acoustic impedance. Where standard methods are available, consideration should be given to include the measurement of these parameters in any investigations which involve the determination of the ultimate strength properties of timber in structural sizes.

6.2.2 Modulus of Elasticity. An important indicating parameter, and one to which those in 5.2.1 may be related, is modulus of elasticity measured over a relatively short span under a constant bending moment. For the determination of this parameter the following test procedure shall be used.

Each specimen or the piece from which it will be cut if the specimen itself is not of sufficient length, shall be symmetrically loaded on edge as a joist, as shown in Figure 2. The distance between the inner load points shall be 1 m with the critical section located at the centre. The centre deflection shall be measured over a gauge length of 900 mm with the deflectometer located at the centre of depth of the section. Load shall be applied either at a continuous rate or in discrete increments and a record of load deflection shall be made so that the deflection  $\delta$  under a load of P(N) can be accurately assessed.

If continuous loading is used the rate of cross-head movement of the testing machine shall be such as to induce a rate of straining in the extreme fibres of 0.003 per min. The rate of cross-head movement shall be determined as:

$$R = (2a + 3000) Z_a/3h \text{ mm/min} \pm 2\%$$

where  $a$  is the distance (mm) between an inner load point and the nearest support which shall not be less than  $3h$

$Z$  is the rate of straining, 0.003 per min

$h$  is the nominal depth (mm) of the section.

The modulus of elasticity shall be calculated as:

$$E = Pa_1^2/16 I \delta \text{ N/mm}^2$$

where  $\delta$  is the deflection (mm) under an increment of load P(N)

$a$  is the distance (mm) between an inner load point and the nearest support which shall not be less than  $3h$

$l_1$  is the gauge length, 900 mm

and  $I$  is the second moment of area of the actual cross-section ( $\text{mm}^4$ )

The modulus of elasticity shall be recorded to three significant figures and the equipment used shall be capable of achieving at least this accuracy.

## 7 STRENGTH TESTS

### 7.1 Bending

These tests provide for the measurement of modulus of elasticity, shear modulus and ultimate bending strength parallel to the grain.

7.1.1 Modulus of Elasticity. Each test specimen shall have a gauge length equal to 18 times the nominal depth of the section, plus 150 mm, with the critical section at the centre. It shall be loaded in third-point bending over a span of 18 times the nominal depth as shown in Figure 3. If the test equipment does not permit these conditions to be determined exactly then the distance between the inner load points may be increased by an amount not greater than  $1\frac{1}{2}$  times the nominal depth and the span and length of specimen may be increased by an amount not greater than 3 times the nominal depth, while maintaining the symmetry of the test.

The specimen shall be supported on rollers and a fixed knife edge reaction, or by devices which achieve an acceptable free support condition. Small metal plates of a length not greater than 50 mm shall be inserted between the specimen and the loading heads and supports to minimise indentation. If the depth to width ratio of the specimen exceeds four lateral restraint shall be provided both outside and inside the loading heads as necessary to prevent buckling. The restraints shall permit vertical movement without significant frictional resistance. Deflections shall be measured from, and relative to, the centre of depth of the specimen.

Load shall be applied either at a continuous rate or in discrete increments and a record of load/deflection shall be made so that the deflection  $\delta$  under a load of P(N) can be accurately assessed. If continuous loading is used the rate of cross-head movement of the testing machine shall be such as to induce a rate of straining in the extreme fibres of 0.003 per min. The rate of cross-head movement shall be determined as:

$$R = (3l-4a) \frac{\dot{\epsilon} a}{3h} \text{ mm/min} \pm 25\%$$

where  $l$  is the total span (mm)

$a$  is the distance (mm) between an inner load point and the nearest support

$\dot{\epsilon}$  is the rate of straining, 0.003 per min

$h$  is the nominal depth (mm) of the section.

Provision is made for the determination of (a) an apparent modulus of elasticity ( $E_a$ ) which includes a shear deflection component and (b) a true modulus of elasticity ( $E$ ) under constant bending moment, ie free from shear.

(a) Apparent modulus of elasticity ( $E_a$ ) shall be calculated as:

$$E_a = (3l^2 - 4a^2) Pa / 48 I \delta_1 \quad \text{N/mm}^2$$

where  $\delta_1$  is the centre deflection (mm) measured relative to the supports for a total load increment of  $P(N)$ , obtained from a record of load/deflection below the proportional limit.  $I$  is the second moment of area ( $\text{mm}^4$ ) of the actual cross-section  
and the other symbols are as defined above.

(b) modulus of elasticity ( $E$ ) shall be calculated as:

$$E = Pa l_1^2 / 16 I \delta_2 \quad \text{N/mm}^2$$

where  $l_1$  is the gauge length (mm) equal to five times the nominal depth of the specimen, centred at the middle of the span.

$\delta_2$  is the centre deflection (mm) relative to the gauge length  $l_1$  for a total load increment of  $P(N)$  obtained from a record of load/deflection below the proportional limit,

and the other symbols are as defined above.

Modulus of elasticity shall be identified by the above symbols and the value shall be recorded to three significant figures. The equipment used shall be capable of achieving at least this accuracy.

7.1.2 Shear Modulus. Two test methods are recommended for the determination of the shear modulus of structural timber. Availability of test equipment will largely determine which one to use but it must be recognised that the methods will yield somewhat different results.

Method A Each test specimen after being tested in accordance with 6.1.1 shall be retested in centre point bending with the gauge length of 6.1.1(d) as the span. The deflection at the centre shall be measured relative to the supports with the deflectometer attached at the centre of depth of the section, as shown in Figure 3. Load shall be applied either at a continuous rate or in discrete increments and a record of load/deflection shall be made so that the deflection  $\delta_3$  under a load  $P(N)$  can be accurately assessed. If continuous loading is used the rate of cross-head movement of the testing machine shall be such as to induce a rate of straining in the extreme fibres of 0.003 per min. The rate of cross-head movement of the testing machine shall be determined as:

$$R = Z l_1^2 / 6h \quad \text{mm/min} \pm 25\%$$

where  $Z$  is the rate of straining, 0.003 per min

$l_1$  is the span (mm)

and  $h$  is the nominal depth (mm) of the section.

From a record of the load/deflection characteristics below the proportional limit the shear modulus ( $G$ ) shall be calculated as:

$$G = 0.3/A \left[ \delta_3 / P l_1 - l_1^2 / 48 E I \right] \quad \text{N/mm}^2$$

where  $A$  is the area ( $\text{mm}^2$ ) of the cross-section  
 $\delta_3$  is the deflection (mm) under on load increment of  $P(N)$   
 $l_1$  is the span (mm) equal to the gauge length in 6.1.1.(b)  
 $E$  is the modulus of elasticity determined in 6.1.1.(b)  
 and  $I$  is the second moment of area ( $\text{mm}^4$ ) of the actual cross-section.

Method B. Each specimen shall be tested in centre point bending over a number of spans with the critical section always at the centre of the span. Not less than six spans should be tested over the range of from 5 to 30 times the nominal depth of the section, so chosen as to give approximately equal increments of  $(h/l)^2$ . The deflection at the centre shall be measured relative to the supports with the deflectometer attached at the centre of depth of the section. Load shall be applied either at a continuous rate or in discrete increments and a record of load/deflection shall be made so that the deflection  $\delta_4$  under a load of  $P(N)$  can be accurately assessed. The apparent modulus of elasticity shall be calculated for each span as:

$$E_a = Pl^3/48 I\delta_4 \quad N/\text{mm}^2$$

where  $\delta_4$  is the centre deflection (mm) under a load increment of  $P(N)$   
 $l$  is the span (mm)  
 $I$  is the second moment of area ( $\text{mm}^4$ ) of the actual cross-section.

From the slope (c) and intercept (b) of a straight line drawn through a plot of  $1/E_a$  against  $(h/l)^2$ , where  $h$  is the depth (mm) of the actual section as shown in Figure 4, the modulus of elasticity  $E$  and shear modulus shall be calculated as:

$$E = 1/b \quad N/\text{mm}^2$$

and  $G = 1.2/c \quad N/\text{mm}^2$

The value of shear modulus shall be recorded to two significant figures and the equipment used shall be capable of achieving at least this accuracy.

NOTE - Method A requires very accurate measurements of deflection and method B assumes that  $E$  is constant over all the spans tested.

7.1.3 Ultimate bending strength. The test arrangement shall be the same as for 6.1.1. Load shall be applied at a continuous rate to induce a rate of straining in the extreme fibres of 0.003 per min, the rate of cross-head movement being determined as in 6.1.1. Each specimen shall be loaded continuously to fracture and the ultimate bending stress calculated as:

$$\sigma_b = P^1 a / 2W \quad \text{N/mm}^2$$

where  $P^1$  is the maximum total load (N)  
 $a$  is the distance (mm) between an inner load point and the nearest support  
 $W$  is the section modulus ( $\text{mm}^3$ )

The value of ultimate stress shall be recorded to three significant figures and the equipment used shall be capable of achieving at least this accuracy. The mode of fracture shall be recorded together with the grade determining properties at the fracture section if this is different from the previously identified critical section.

## 7.2 Tension

These tests provide for the measurement of modulus of elasticity and ultimate tension strength parallel to the grain.

7.2.1 Modulus of Elasticity. Each specimen shall be of the full cross-section and of a total length sufficient to provide a test length, clear of the grips of at least 9 times the nominal width of the specimen, ie the dimension of its widest face. The specimen shall have the critical section within  $\pm 1\frac{1}{2}$  times the nominal width from the centre. The specimen shall be loaded continuously using gripping devices which permit the application of uniform tension without inducing bending. It is preferably recognised that the necessary alignment and rotational freedom may not be attained in practice and the actual gripping devices and loading conditions used should therefore be recorded. Load shall be applied at a continuous rate to induce a rate of straining of 0.003 per min, the rate of cross-head movement of the testing machine being determined as:

$$R = \frac{Zl}{60} \text{ mm/min} \pm 25\%$$

where  $l$  is the specimen length (mm) between the grips

and  $Z$  is the rate of straining, 0.003 per min.

If there is significant movement associated with the functioning of the gripping devices, eg with wedge type grips, preliminary tests should be made to establish a rate of cross-head movement which induces an average rate of straining of 0.003 per min.

Deformation shall be measured over a gauge length equal to five times the nominal width and located not closer than twice this width from the ends of the grips. The gauge length shall include the critical section. Two extensometers shall be used, and shall be attached at diagonally opposite points on each face of the specimen to minimise the effects of distortion and permit the determination of the average deformation over the full gauge length. From a record of load/deformation the modulus of elasticity shall be calculated as:

$$E = Pl / A\delta \quad \text{N/mm}^2$$

where  $\delta$  is the average deformation (mm) under a load increment of  $P(N)$

$l$  is the gauge length (mm)

and  $A$  is the area ( $\text{mm}^2$ ) of the actual cross-section.

The value of modulus of elasticity shall be recorded to three significant figures and the equipment used shall be capable of achieving at least this accuracy.

7.2.2 Ultimate Tension Strength. The test arrangement and rate of straining shall be the same as in 7.2.1. Each specimen shall be loaded continuously to fracture and the ultimate tension stress shall be calculated as:

$$\sigma_t = P^1/A \quad \text{N/mm}^2$$

where  $P^1$  is the maximum load (N)

and  $A$  is the area ( $\text{mm}^2$ ) of the actual cross-section.

The value of ultimate stress shall be recorded to three significant figures and the equipment used shall be capable of achieving at least this accuracy. The mode of fracture shall be recorded together with the grade determining properties at the fracture section if this is different from the previously identified critical section.

### 7.3 Compression

These tests provide for the measurement of modulus of elasticity and ultimate compression strength parallel to the grain.

7.3.1 Modulus of Elasticity. The length of each specimen shall be seven times its nominal width, ie the dimension of its widest face, and shall have the critical section  $\pm 1\frac{1}{2}$  times the nominal width from the centre. The end surfaces of each specimen shall be accurately prepared to ensure that they are plain and parallel to each other. To prevent buckling the faces and edges shall be restrained at a sufficient number of points so that there is no free length greater than five times its nominal dimensions. The specimen shall be loaded continuously using spherical seated loading heads or other devices which permit the application of uniform compression without inducing bending. Load shall be applied at a continuous rate to induce a rate of straining of 0.003 per min, the rate of cross-head movement of the testing machine being determined as:

$$R = \underline{21} \text{ mm/min} \pm 25\%$$

where  $l$  is the specimen length (mm)

and  $\underline{21}$  is the rate of straining, 0.003 per min.

Deformation shall be measured over a central gauge length of five times the nominal width of the specimen. Two compressometers shall be used and shall be attached at diagonally opposite points on each face of the specimen to minimise the effects of distortion and permit the determination of the average deformation over the full gauge length. From a record of load/deformation the modulus of elasticity shall be calculated as:

$$E = Pl/A\delta \quad \text{N/mm}^2$$

where  $\delta$  is the average deformation (mm) under a load increment of  $P$ (N)

$l$  is the gauge length (mm)

and  $A$  is the area ( $\text{mm}^2$ ) of the actual cross-section.

The value of modulus of elasticity shall be recorded to three significant figures and the equipment used shall be capable of achieving at least this accuracy.

7.3.2 Ultimate Compression Strength. The loading conditions and the preparation of each specimen shall be as in 7.3.1. The length of the specimen to be six times its nominal thickness, ie its least dimension, and shall contain the critical section within  $\pm 1\frac{1}{2}$  times the nominal thickness from the centre. The rate of cross-head movement of the testing machine shall be determined, for the changed length of specimen, as in 7.3.1. to achieve a rate of straining of 0.003 per min. Each specimen shall be loaded continuously to fracture and the ultimate compression stress calculated as:

$$\sigma_c = P/A \quad \text{N/mm}^2$$

where  $P$  is the maximum load (N)

and  $A$  is the area ( $\text{mm}^2$ ) of the actual section.

The value of ultimate stress shall be recorded to three significant figures and the equipment used shall be capable of achieving at least this accuracy. The mode of fracture shall be recorded together with the grade determining properties at the fracture section if this is different from the previously identified critical section.

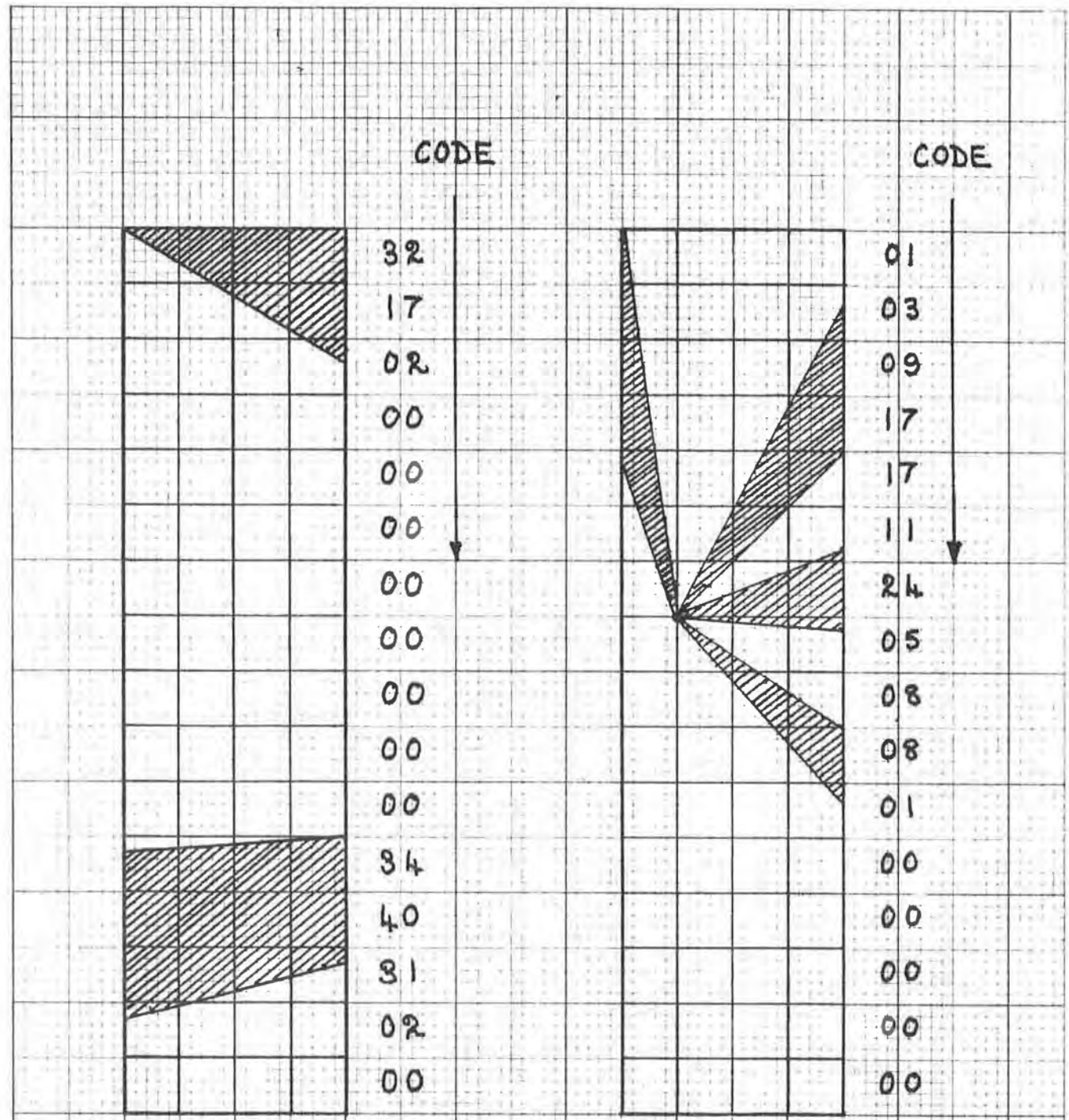

TENSION

TENSION

STANDARD 4x16 GRID.

FIG 1.

KNOT PLOTS AND NUMERICAL CODE.

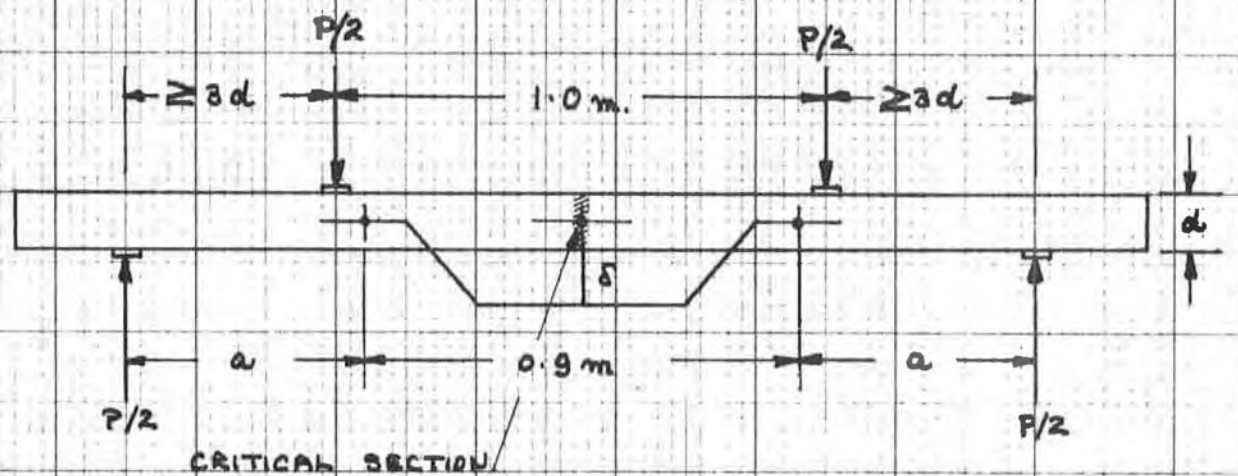
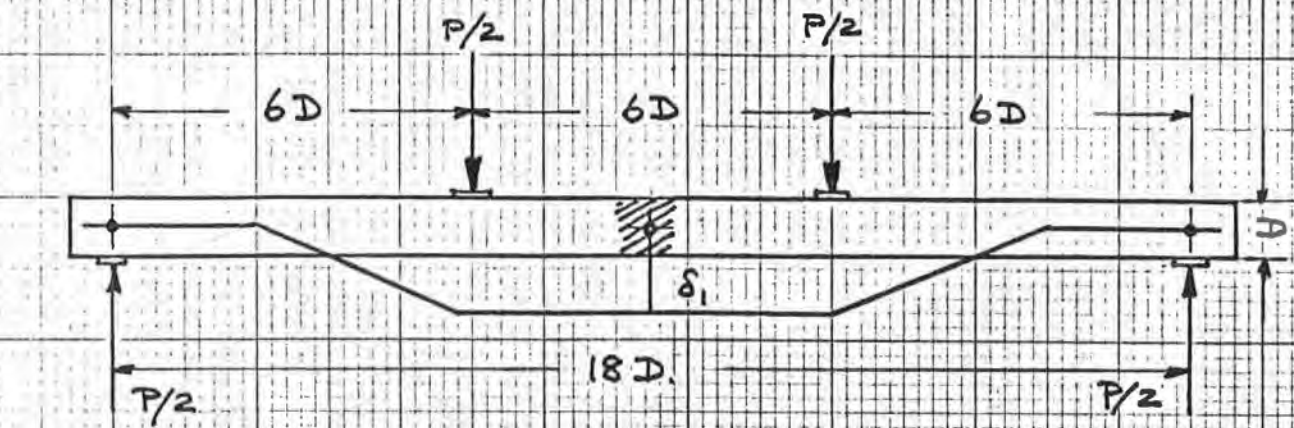
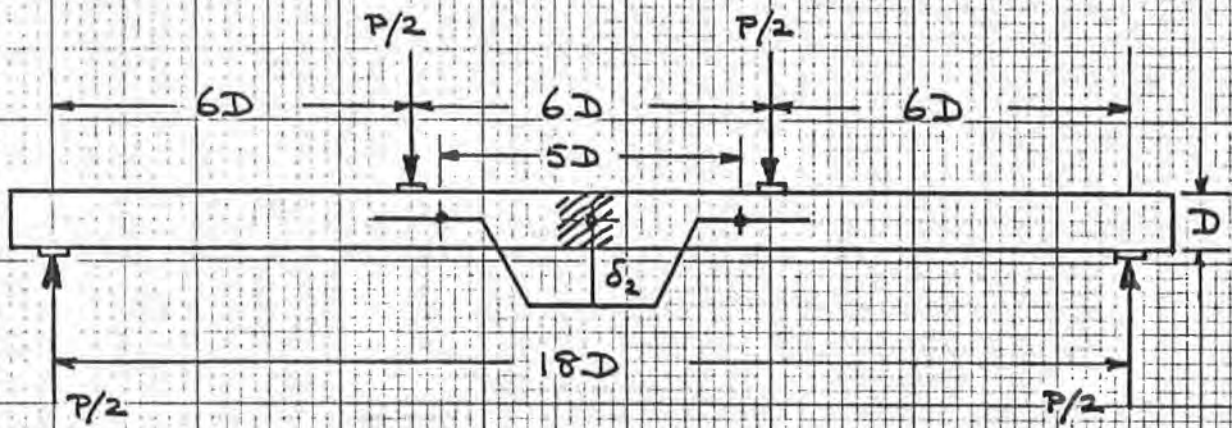

FIG 2.

DEFLECTION MEASUREMENT IN BENDING : GRADE  
 DETERMINING PROPERTIES MECHANICAL : MODULUS OF  
 ELASTICITY.



(a)



(b)

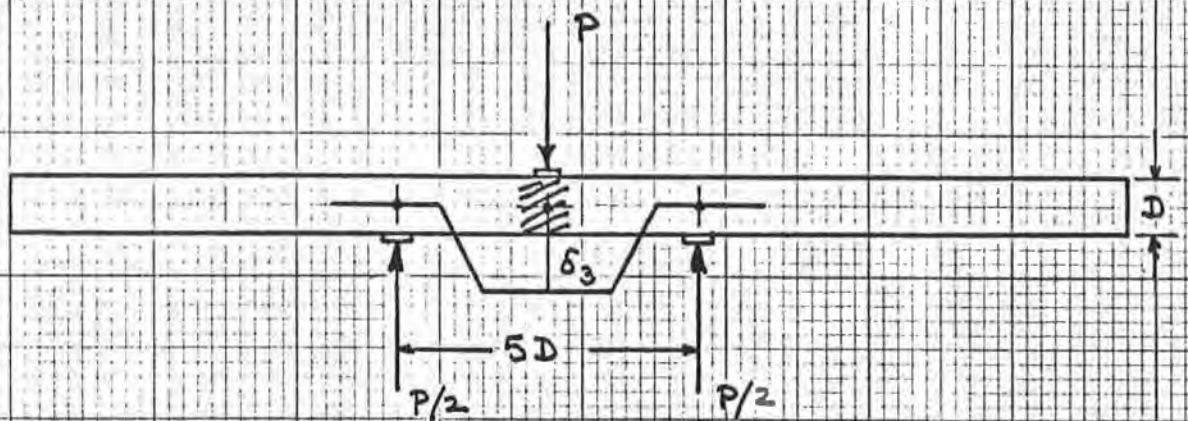

(c)

CRITICAL ZONE

FIG. 3.

DEFLECTION MEASUREMENTS IN BENDING.  
 MODULUS OF ELASTICITY AND SHEAR MODULUS

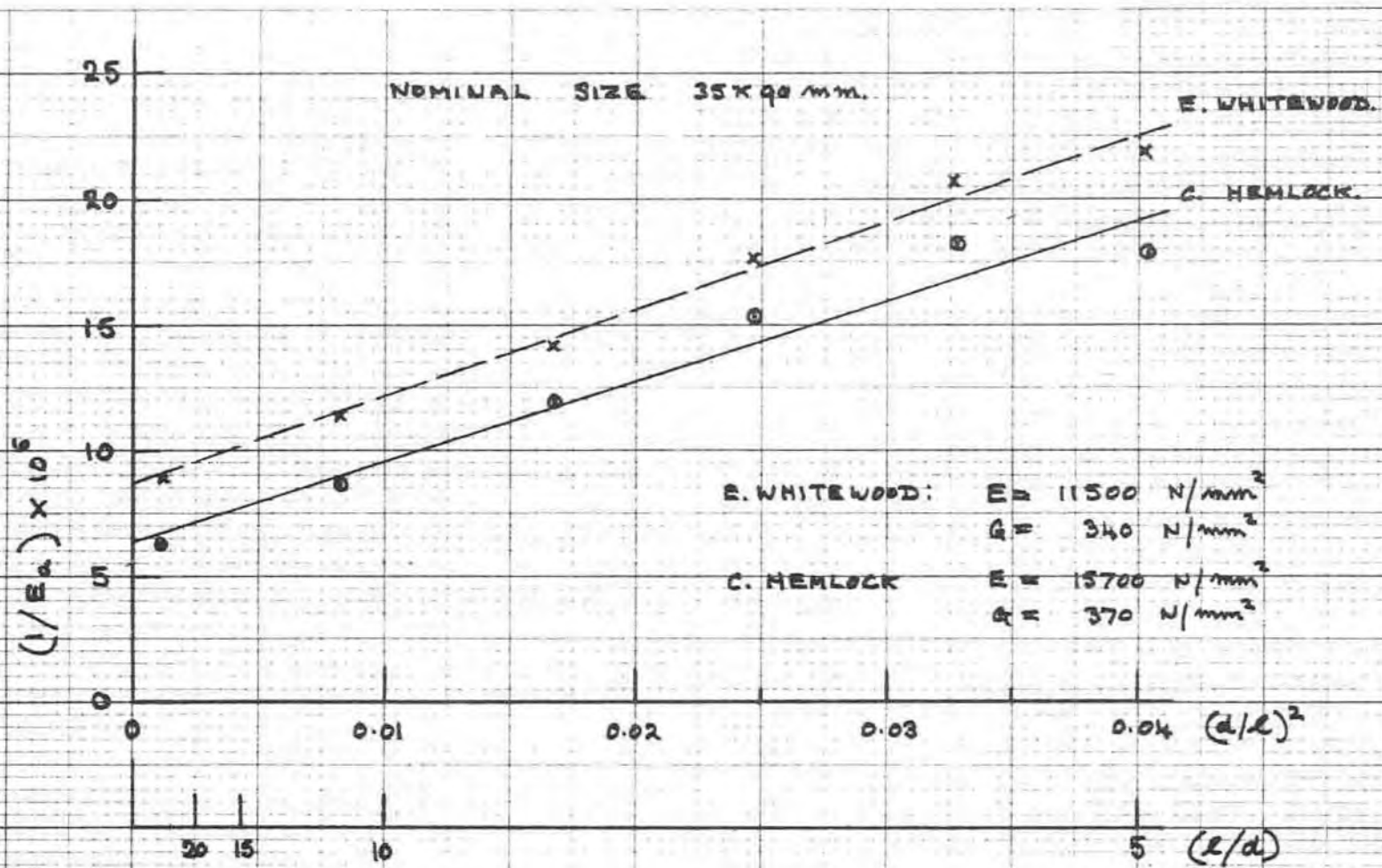

FIG 4.

DETERMINATION OF SHEAR MODULUS. (G.)

INTERNATIONAL COUNCIL FOR BUILDING RESEARCH STUDIES AND DOCUMENTATION  
WORKING COMMISSION W18 - TIMBER STRUCTURES

RECOMMENDATIONS FOR TESTING METHODS FOR JOINTS WITH MECHANICAL  
FASTENERS AND CONNECTORS IN LOAD-BEARING TIMBER STRUCTURES -  
RILEM 3TT COMMITTEE  
(SEVENTH DRAFT)

RILEM 3TT COMMITTEE

RILEM recommendations for testing methods for joints with mechanical fasteners and connectors in load-bearing timber structures.

### Introduction

Developments in the field of load-bearing structures give way to the problem that very often joint connectors should be tested to gather new or more information about their deformations and load-bearing capacity.

The present recommendations give some general principles which should be followed in order to reach a better comparability of results from investigations carried out in different laboratories.

For determining values of the characteristic strength or allowable loads general guide lines have been given in the "Recommendations for the evaluation of results of tests on joints with mechanical fasteners and connectors for load-bearing timber structures."

### 1. Scope

A method is developed:

- .1. to investigate the mechanical properties of timber joints with mechanical fasteners and connectors.
- .2. to determine values of the deformation in the joint which enable designers to introduce these in their calculation.

### \*2. Fields of application

This code of testing practice is applicable to joints destined for application in statically loaded timber structures with mechanical fasteners and connectors.

---

\* On page 5. etc. a comment is given about paragraphs marked with a \*

\*3. Conditioning of test specimens

Attention should be paid both to the conditioning of the timber before the manufacturing of the joint as well as to the conditioning of the joints as a whole before testing. The pre-conditioning should be conducted in such a way that the moisture content  $\psi$  of the wood, the effects of shrinkage, etc. can influence in a realistic manner the strength properties of the wood, the occurrence of gaps, etc., so as to guarantee a good comparability between the performance of the test joints and the joints in a structure.

4. Form and dimensions of test specimens

- .1. The joints to be tested in the investigation must be of such realistic form and dimensions that the necessary information about strength and deformation in actual service can be achieved.
- .2. Detailed information about form and dimensions of test specimens suitable for different types of mechanical connectors will be given in relevant appendices.
- .3. The number of connectors in a joint should be chosen in accordance with 4.1. and correspond to the character of the joint.

\*5. Extent of investigation

The extent of the investigation must be such that a statistical treatment of the available data can take place. The number of tests depends upon the goals of the investigation.

6. Loading procedures

.1. Short duration test or standard test

- .1. An expected value of the ultimate load  $\hat{F}$  of the joint to be tested has to be determined on the basis of former experience, calculations, preparatory test or otherwise.

6. 1.2. The loading procedure has been given in fig. 2; each load increment  $f = 0,1 \hat{F}$ .

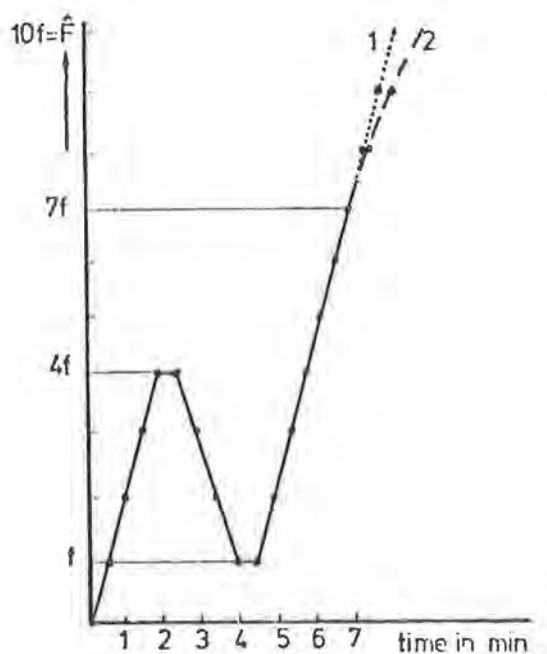

Fig. 1. Loading procedure

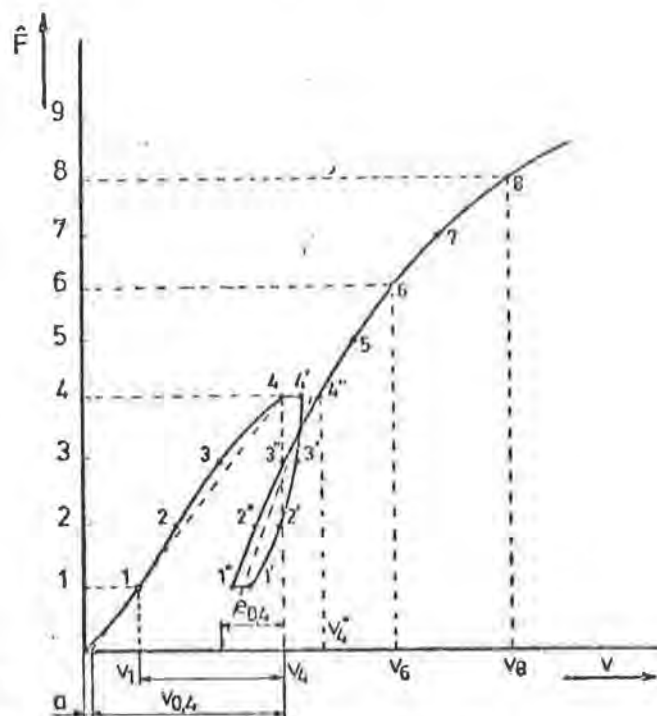

Fig. 2. Idealised load-deformation curve and measurements.

The testload is raised with a constant rate of loading or a constant rate of deformation up to  $4f$ , then -after 30 sec - diminished to  $f$  and - after another 30 sec waiting time - raised again. Each load increment takes 30 sec. Above a load of  $7f$  a constant rate of deformation may be maintained until failure. If large deformations occur a gradual acceleration is allowed to achieve a total test time of 10 to 15 min.

The standard test will be stopped after failure or if displacement of 15 mm in the joint is reached.

3. At each load-increment or - decrease the deformation should be measured in such a way that the continuity of the loading procedure is not be disturbed to an essential degree.

6.1.4. From the measurements the following data can be calculated:

"virgin" displacement  $v_{0,4} = 4/3 (v_4 - v_1)$

joint slip  $a = v_4 - v_{0,4}$

elastic displacement  $e_{0,4} = 4/3 \left( \frac{v_4' + v_4''}{2} - \frac{v_1' + v_1''}{2} \right)$

joint stiffness  $k_{0,4} = \frac{v_{0,4}}{4r}$

displacement at

overload  $v_{0,6} = v_{0,4} + v_6 - v_4''$

$$v_{0,8} = v_{0,4} + v_8 - v_4''$$

5. If during the execution of the investigation the average ultimate load  $\hat{F}$  of two more executed tests turn out to differ more than 20% of the expected  $\hat{F}$ -value adjustments of the loading procedure for the following tests should be made.

The already obtained values of  $\hat{F}$  may be maintained in the final results; the values of  $v_4$  etc. must be recalculated or estimated from the load slip diagram.

6. The ultimate load is taken to be the maximum load reached within a displacement in the joint of 15 mm.

#### 6.2. Long duration tests.

1. Information about the trust-worthiness of joints on the long run can be gathered from long duration-tests.

2. Suggestion is made to use two load levels:

- at a continuous load of  $0,80\hat{F}$  and
- at a continuous load of  $0,40\hat{F}$

In both cases the deformations shall be measured at suitable intervals.

The long-duration tests may be stopped after a period of 3 months.

#### 7. Test reports

Reports on tests must give all reliable data about the tests carried out and the results. They shall therefore contain data about:

- species and quality of the wood (relevant strength properties,

strength grade following standard .....and in any case (relative density)

- Material, quality and strength properties of the connectors; eventual treatment against corrosion.
- the dimensions of the joints, number of connectors therein loading method in the test machine etc.
- conditioning of timber and test specimens before and after manufacturing; moisture content at the time of testing, gaps between members, etc.
- load procedure followed
- all individual test results; mean values and standard deviations
- mode of failure.

#### COMMENTARY

1. In case of time-dependent live loads where variance of intensity occur with frequencies higher than  $\frac{1}{2}$  to  $\frac{1}{3}$  of the lowest frequency of the structure itself, dynamic effects must be expected. In many cases, like floors of ballrooms, gymnastic halls, etc. these effects have already been taken into account by the introduction of equivalent live loads in the loading standards and/or by stiffness requirements.
2. The climatic conditions in which a joint is supposed to function influence its strength and its deformation. Four basic conditions can be distinguished:
  - normally heated, and sufficiently ventilated buildings;
  - not heated, closed buildings;
  - not heated, open buildings but with covered structure;
  - unprotected open air exposure.

Although the basic conditions vary considerably between geographic positions it may be possible to circumscribe the average climatic data for certain regions and to derive therefrom a range from which the moisture content of the timber will not differ for longer than 2 weeks in a period of 5 years, disregarding surface conditions.

For great parts of Western Europe such figures are given in table 1.

Table 1. Average moisture contents to be expected in European softwoods, used in Western Europe,

Climatic conditions	moisture content %
heated and ventilated buildings	$9 \pm 3$
not heated, closed buildings	$12 \pm 3$
not heated, covered buildings with open walls	$15 \pm 3$
open air	$\geq 18$

4. Efforts are being made to prepare a first appendix about the testing of joints with nail plates (like Gangnail, Hydronail, etc.)
5. Dependent on the wanted information different types of investigation can be distinguished:
- a. in a systematic investigation information is wanted in a very general way, including dimensions of the connector, the timber, angle of load to grain etc.
  - b. in a limited investigation information is wanted about the behaviour of a certain type of connector in different positions, e.g. with respect to angle of load to grain but with pre-fixed minimum-values of timber dimensions, edge- and end-distances etc.
- For instance a joint with punched metal plates

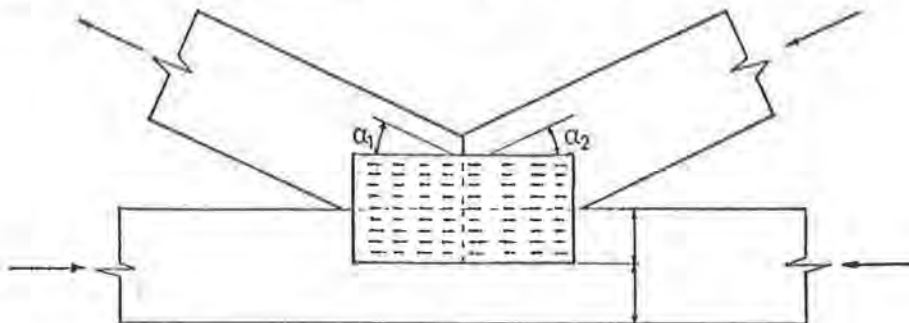

- c. In a special investigation information is wanted about the behaviour of a certain joint with fixed dimensions and in known circumstances.

For instance an "grip" - connector for the connection of the secondary beam to a

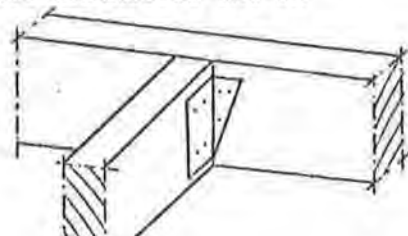

primary beam of certain dimensions.

6. Results of long-duration-tests on normally used types of connectors as well as on clear wood show that tests on a level of  $0,8\hat{F}$  will last not longer than the period of 3 month. In the CIB-W18-recommendations it is said that: "collapse of the total number (of test specimens with this load) shall not occur within a period of 100 hours".

INTERNATIONAL COUNCIL FOR BUILDING RESEARCH  
STUDIES AND DOCUMENTATION

WORKING COMMISSION W18

PROPOSAL

*Möhlner*

TESTING OF INTEGRAL NAIL-PLATES  
AS TIMBER JOINTS

by

K MÖHLER, UNIVERSITY KARLSRUHE

AALBORG - JUNE 1976

TESTING PUNCHED METAL PLATES AS TIMBER CONNECTORS:  
GUIDE-LINES (Code of Practice) FOR TESTING

1 GENERAL

These guide-lines are intended to promote uniform methods of testing punched metal plates as connectors for load-bearing timber structural members.

2 CONCEPT AND TREATMENT

Punched metal plates as understood in these guide-lines normally comprise steel plates having a thickness at least 1 mm, corrosion-proofed on both sides, with nail- or spike-type parts punched out towards one side and bent up at right angles to the plane of the plate.

The punched metal plates serve as splice-plates or gusset-plates for connecting two or more timbers of equal thickness. For this purpose they are pressed, by means of a special platen or roller press, into the surface of the timber to a depth such that the plate is lying flush and the punched-out parts are embedded in the timber over their full length.

3 THE PURPOSE OF THE TESTS

The purpose of the tests is to provide information for design, construction of the timber connections and inspection: The following are the design data required:

- a) Permissible force  $F_F$  in  $N/mm^2$  ( $kp/cm^2$ ) at the contact surface area between punched metal plate and timber surface, as a function of the angle  $\alpha$  (angle between the direction of the force and of the plate) and of the angle  $\beta$  (angle between the direction of the force and of the grain); or
- b) Permissible force  $F_A$  in  $N(kp)$  per punching as a function of angles  $\alpha$  and  $\beta$  (especially with spike-type punchings);
- c) Permissible force  $F_Z$  in  $N/mm$  ( $kp/cm$ ) of plate width (without subtracting the apertures), under tensile stress with  $\alpha = 0^\circ$  and  $\alpha = 90^\circ$  for  $\beta = 0^\circ$ ;

d) Permissible force  $F_S$  in N/mm (kp/cm) of plate width (without subtracting the apertures), under shear stress, as a function of angle  $\alpha$ .

#### 4 PRELIMINARIES TO TESTING

##### 4.1 Choice of plate sizes for testing:

Choice of 2 to 3 plate sizes from the production programme of the client in such a way that the required calculation values for all plate sizes can be obtained with adequate reliability by interpolation. When the size of the plate does not affect the load-bearing capacity, it is sufficient to test 1 size of plate.

##### 4.2 Data required before start of testing:

Data regarding corrosion-proofing, elongation limits and tensile strength of the initial material (steel plate) to be provided by the client. Where the client has no special requirements (eg special types of execution), the following conditions are laid down:

Type of timber: spruce, planed (if required other species and sawn timbers are tested)

Thickness of timber:  $2 \times$  length of punchings  $+ \approx 5$  mm, but not less than 35 mm

Moisture content,

at production:  $\approx 22\%$

at testing :  $18 \pm 2\%$

Compressive strength:  $36 \pm 2$  N/mm<sup>2</sup>

(at  $U = 15\%$ ) (360  $\pm$  20 kp/cm<sup>2</sup>)

For compressive strengths above 38 N/mm<sup>2</sup> (380 kp/cm<sup>2</sup>) the test results, in so far as failure occurs in the timber, must be multiplied by the factor  $\alpha = 36/\sigma_{D11}$ ; where  $D_{11}$  is the compressive strength of the wood used.

The test pieces are prepared at the testing institute or at the works under the supervision of an officer of the testing institute.

A cutting plan is to be prepared for removing the timber test-pieces from the plank, in such a way as to ensure comparability of the test results.

## 5 THE TESTS

### 5.1 Material characteristics:

5.1.1 Material characteristics of the steel plate: Determination of tensile strength, elongation limits, elongation at breaking point, and hardness of the steel plate before punching, and determination of corrosion-proofing according to the relevant regulations.

5.1.2 Material characteristics of the punched metal plates: Determination of the bending behaviour of the punched nails (bending-back test) by repeated bending up and down up to  $45^\circ$ , starting by the bending on punching out, and determination of the number of bendings up to fracture. Similar tests should be carried out on plates with spike-type punchings.

### 5.2 Testing of timber connectors:

5.2.1 Static tests on individual test pieces: Determination, by preliminary tests, of the maximum loading  $F_{\max}$  to be expected.

Loading is effected continuously up to  $0.4 F_{\max}$  with recording of the load/displacement line with a loading rate of  $0.2 F_{\max}/\text{min}$  or a deformation rate of the testing machine cross-head of 1 mm/min to 1.5 mm/min. After half a minute loading is reduced to  $0.1 F_{\max}$ , and after a further half-minute continuous loading is resumed at the above indicated loading rate up to  $0.7 F_{\max}$ , displacement being read at intervals of  $F/10$ . This is followed by loading to maximum load with a higher rate of deformation (about 4 mm/min).

For each type of test, at least 5 similar test pieces are to be tested.

With each test piece, two plates of the same size are to be placed symmetrically with respect to the 1 mm wide vertical joint as splice-plates. In the tensile and transverse-tensile tests, the edges of the clamping device are to be at a distance of at least 20 cm from the ends of the plates.

#### 5.2.1.1 Tensile tests:

a) Set-up of the test piece for failure of the punchings.

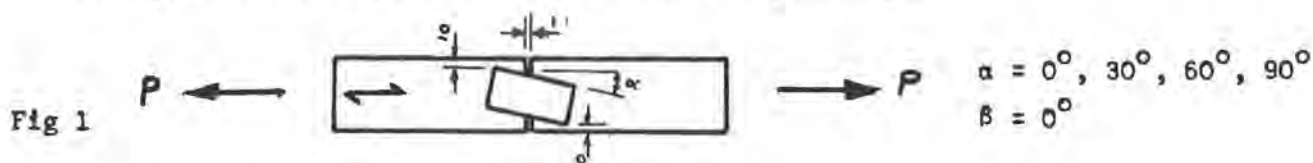

It is generally sufficient to test the longest plate for which failure of the nails is to be expected.

b) Set-up of the test piece for failure of the steel plate

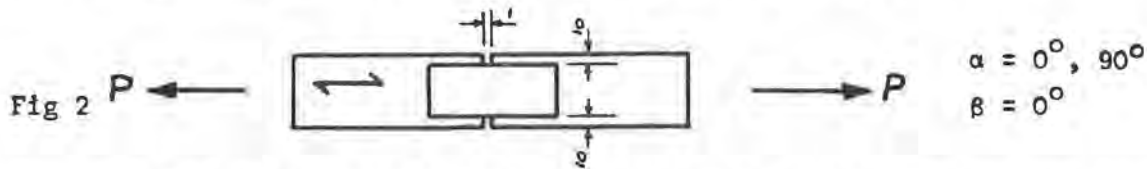

The length of plate must be chosen on the basis of the test results in 5.2.1.1 in such a way that failure occurs in the plate.

5.2.1.2 Transverse-tensile tests:

Set-up of the test piece

Fig 3

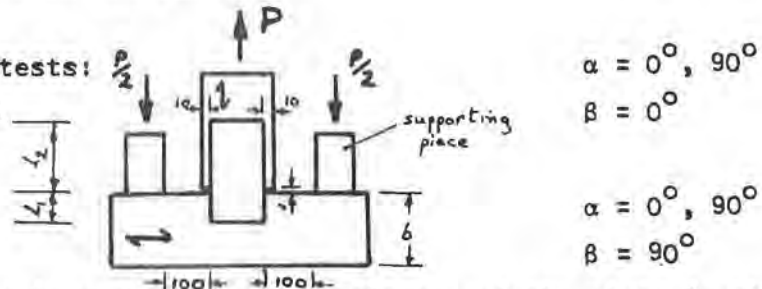

The plates should be arranged in such a way that failure, of the plate in the region of the cross-timber is ensured ( $l_1 \leq l_2$ ). Length  $l_1$  should be first  $> b/2$  then  $< b/2$ . The application of the load should be effected flexibly.

5.2.1.3 Compression tests:

In the case of impacts and application of compression struts it can be assumed that the force is transmitted directly via the contact surface to the connecting timber; for this reason compression tests are usually unnecessary.

5.2.1.4 Shear tests:

Only shear tests and tensile shear tests have to be made, since compression shear tests are not allowable.

Set-up of the test pieces

Fig 4

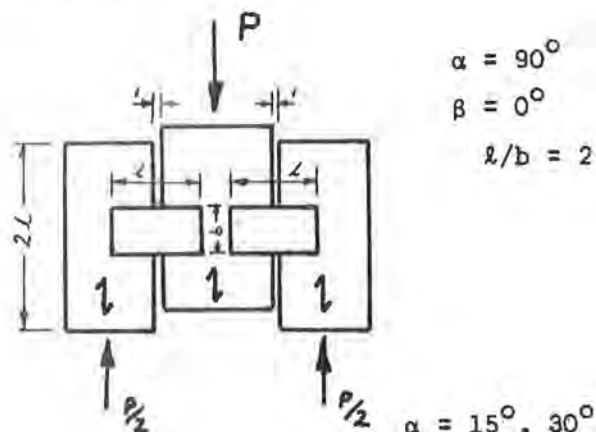
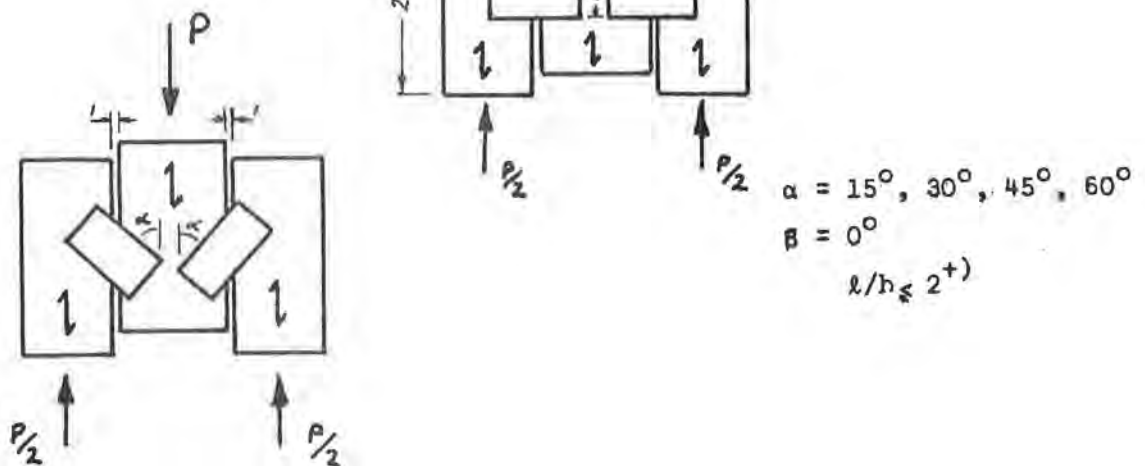
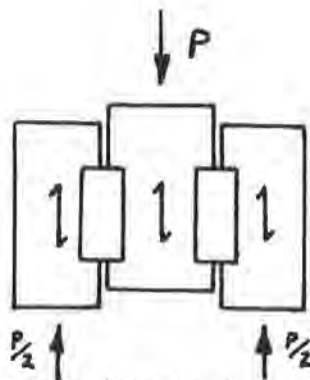

Fig 5



\*In each case with variation of the ratio  $l/b$  by tests on additional plate sizes.

Fig 6



$$\alpha = 0^\circ$$
$$\beta = 0^\circ$$
$$l/b \approx 2^m$$

5.2.2 Dynamic tests (continuous oscillation tests) with individual test pieces: Tests on special request, eg when using the plates for crane or bridge building. Alternating load tests with test pieces according to 5.2.1.

Determination of top and bottom load and of the number of load alternations before fracture. Measurement of deformations as a function of the load alternations.

5.2.3 Time (endurance) tests with individual test-pieces: Tests on special request, eg for use in structural members with a high continuous component of load. Test piece in accordance with 5.2.1.

Intensity of loading between 50% and 70% of the static breaking load.

5.2.4 Static tests with structural members: Tests on special constructions, eg with dowelled beams with special plate sizes.

---

\*In each case with variation of the ratio  $l/b$  by tests on additional plate sizes.

INTERNATIONAL COUNCIL FOR BUILDING RESEARCH STUDIES AND DOCUMENTATION  
WORKING COMMISSION W18 - TIMBER STRUCTURES

RULES FOR EVALUATION OF VALUES OF STRENGTH AND DEFORMATION FROM  
TEST RESULTS - MECHANICAL TIMBER JOINTS

by

M JOHANSEN, Statens Byggeforskningsinstitut, Copenhagen  
J KUIPERS, Technische Hogeschool, Delft  
B NORÉN, Svenska Träforskningsinstitutet, Stockholm

RULES FOR EVALUATION OF VALUES OF STRENGTH AND DEFORMATION  
FROM TEST RESULTS - MECHANICAL TIMBER JOINTS

M Johansen, Statens Byggeforskningsinstitut, Copenhagen  
J Kuipers, Technische Hogeschool, Delft  
B Norén, Svenska Träforskningsinstitutet, Stockholm

Introduction

The rules are divided into a general section and a section for mechanical timber joints. The general section will be replaced by a reference to "General rules for building materials and constructions" once such rules are agreed upon. The examples refer to certain fraction values, but the rules should fundamentally apply to other statistical measures as well. It is assumed that the RILEM-CIB recommendations for testing joints are followed (CIB-W18/6-7-1).

1. General

1.1 Object

The strength or deformation sought as a rule refers to a population from which a small sample is tested. The evaluation of the test results in this respect should be based on recognized statistic methods. Deviation of the testing conditions from the conditions to which the properties shall refer require that the test results are converted. Such conversion is facilitated if a likely theory is available.

1.2 Characteristic values

Characteristic strength and deformation are defined by fraction values, strength normally by the 5-percentile, elasticity and rigidity modulee and related stiffness coefficients for calculating deformation at the serviceability limit state normally by the 30-percentile or the mean value. (The corresponding characteristic deformation is given by the 70-percentile or the mean value.)

1.3 Statistic evaluation

For the statistic estimation of the characteristic strength or deformation of a population on basis of results from tests carried out on a limited sample this sample must as

a rule be drawn at random from the population. If not otherwise stipulated the characteristic values of the population should be estimated at 75 % confidence level. This estimation can be carried out using a distribution-free method or after a reasonable assumption regarding the strength distribution in the population.

Note. When the deviation can be described by a normal distribution and provided the coefficient of variation does not substantially exceed 0.2, characteristic values  $f_k$  are accepted calculated from

$$f_k = f_m (1 - C\delta) \quad (1.3)$$

In (1.3)  $f_m$  is the mean and  $\delta$  the coefficient of variation of the recorded values. The coefficient  $C$  depends on level of confidence, number of recorded values (tested specimens) and the percentile wanted, see table 1.

Tabel 1 Value of  $C$

No. of test values →	4	5	6	8	10	15	20	40
Percentile								
5	2.7	2.5	2.3	2.2	2.1	2.0	1.9	1.8
30	.95	.89	.86	.80	.77	.72	.69	.64
50								

#### 1.4 Conversion

Conversion factors for transforming test results to other conditions than the conditions during testing should coincide with the corresponding factors given in the structural code or otherwise be verified. The conversion factor is applied on the characteristic values ( $f_k$ ) calculated from the recorded test values, or, if proved more correct, on the individually recorded test values.

#### 1.5 Presentation of results

Characteristic values should be specified with respect to percentile (fraction value), duration of stress (short-term and long-term stress respectively) and climate class.

## 2. Mechanical timber joints

### 2.1 Characteristic values with reference to timber grade

2.1.1 When timber to the test joints is selected according to method A (appendix 1, paragraph 2.2.1), characteristic values ( $f_k$ ) can be referred to "softwood D400 (low density)" and "softwood D500 (high density)" respectively.

Note. Conversion of the characteristic values to apply other density values is considered from case to case. The density distribution of the reference wood is assumed to be normally distributed with a coefficient of variation of 0.15. Individual test values ( $f$ ) are not converted.

2.1.2 When the timber to the test joints is selected according to method B (appendix 1, paragraph 2.2.2), characteristic values ( $f_k$ ) are accepted for the reference wood mentioned in 2.1.1 provided the calculation (1.3) is based on converted test values ( $f^1$ ), calculated from

$$f^1 = (350/D_o)^c f \text{ when the mean value of density is } D_{om} \leq 440 \text{ kg/m}^3$$

and

$$f^1 = (430/D_o)^c f \text{ when the mean value of density is } D_{om} \leq 550 \text{ kg/m}^3 \text{ respectively.}$$

$D_o$  = density (mass at  $\psi = 0$ , volume at  $\psi$ ) of the timber of the joint.

$D_{om}$  = mean density for the group of joints tested.

$c$  = exponent ( $1 \geq c \geq 0$ ).

The value of the exponent is verified by testing or by means of a likely theory or otherwise is calculated with  $c = 1$ .

If there is a limit of density,  $D_{OL}$ , above which the influence of the density on the strength of the joint can be neglected (compare plate failure in nail plate joints)  $D_{OL}$  shall be introduced instead of  $D_0$  in the expressions for  $f^1$ , provided  $D_{OL} < D_0$ .

Note. The condition for the presented calculation of characteristic ( $f^1$ ) is that the strength can be related to the density of the wood. The density can be substituted by the compression strength or the shear strength of the wood in correspondence with the type of failure. (The compression strength parallel to the grain can approximately be calculated from  $f_c = 0.95(2 - \psi_0/0.15) N/mm^2$  at a moisture ratio  $0.12 \leq \psi_0 \leq 0.16$ ).

The calculation of characteristic strength of many mechanic joints (and other composite structural parts) are difficult to generalize. Within the approved methods of verification it may be preferable to define two (or more) characteristic values of strength, for example strength at wood failure and strength at failure in the fastener or connector itself.

- 2.1.3 Numerical methods for calculating characteristic strength from the test results can be applied if the number of reported values is sufficiently great.

Note. If uniform wood is used for testing, for example with respect to density, one may refer the deviation of the test results to deviations in the correlation between the wood property (density) and the strength of the joint, i.e. to variation of the coefficient A in  $f = AD^E$ . If E is considered constant, the fraction value of f is calculated by means of the volume describing the frequency of the two-dimensional stocastic variable A, D:  
 $f_{A,D}(x,y)dx dy = f_A(x)dx \cdot f_D(y)dy$ , where  $f_A$  is received from the testing results and  $f_D$  is adjusted with respect to the expected timber quality, for example for the reference classes to the mean density 400 and 500 respectively and normal distribution with the coefficient of variation 0.15.

- 2.1.4 If a theory (model of calculation) is available whereby the strength of the joint (f) can be approximately stated as a function (F) of parameters which represent relevant properties of the connector (C) and the wood (D)

$$f_{\text{theor}} = F(D, C) \quad (:1)$$

the following estimation of the characteristic strength ( $f_k$ ) of the joint is accepted without any other claims on the selection of the timber or the connectors for the testing than that D and C must fall between the limits for the validity of (:1):

$$f_k = \phi_k f_{k \text{ theor}} \quad (:2)$$

In (:2)  $\phi_k$  denotes characteristic value (5-percentile) of the ratio  $\phi = f/f_{\text{theor}}$  where f is the measured strength of the individual joint and  $f_{\text{theor}}$  is the expected strength based on measured values of D and C as calculated from (:1). The value  $f_{k \text{ theor}}$  is obtained from

$$f_{k \text{ theor}} = F(D_k, C_k) \quad (:3)$$

where  $D_k$  and  $C_k$  are the characteristic values of the properties of the wood and the connector respectively in the population of joints to which the characteristic value for the joint shall apply.

Note. The calculation of characteristic value according to 2.1.2 is a special case of the calculation in 2.1.4, which appears from the following example, in which the variation of C is neglected:

$$f_{\text{theor}} = F(D, C) = aD^c \quad \text{where } a \text{ and } c \text{ are constants, thus}$$

$$\phi = \frac{f}{aD^c} .$$

If converted to  $D_k = 350$ , the strength is:

$$f^1 = (350/D)^c f = \phi a 350^c, \text{ i.e. from (:3) } f^1 = \phi f_{k \text{ theor}}$$

$$f_k(2.1.2) = f_k^1 = \phi_k f_{k \text{ theor}} = \hat{f}_k(2.1.4)$$

## 2.2 Conversion for moisture content

- 2.2.1 The joints of a sample are assumed conditioned at a specified climate thus that deviation of moisture content of individual specimens can be neglected (cf. CIB-W18/6-7-1, p. 3).
- 2.2.2 Factors for conversion to other climate (moisture content) than at testing are found from special testing at different climate or calculated by a plausible theory. They are applied on values of individual joints or on sample values (or values calculated for the population from the sample values) whichever is realistic.

Note. At converting from the mean value of moisture content at testing to the nearest M.C.-value corresponding to a standard climate class, it is generally sufficient to convert the sample value.

## 2.3 Strength at sustained load

- 2.3.1 The derivation of conversion factors for the strength at sustained loading requires testing at several load-levels, e.g. 1.2, 1.0, 0.8 and 0.6 times the expected mean strength at short-term loading as well as supplementary short-term testing to determine the strength deviation.
- 2.3.2 The characteristic short-term strength  $f_k^{ST}$  obtained from short-term testing according to CIB-W18/6-7-1 may be converted into characteristic long-term strength by applying a factor  $\gamma$ , provided it is checked by loading of  $N$  joints during  $10^2$  h with a constant load  $0.5(1+\gamma)f_m^{ST}$  that less than  $n$  joints fail during this testing. Hereby  $f_m^{ST}$  denotes a verified mean value of the strength of short-term-tested joints of equal kind.

Acceptable values of the ratio  $n/N$  for different values of  $\gamma$  are given in table 1.

Table 1 Relative number of joints ( $n/N$ ) to resist the load  $0.5(1 + \gamma_5)f_m^{ST}$  during at least  $10^5$ h.

$\gamma_5$	$0.5(1 + \gamma_5)$	$n/N$ ( $N \geq 20$ )
0.8	0.9	?
0.6	0.8	0.50
0.4	0.7	?

Note. The values are based on normal distribution of  $f$ , coefficient of variation  $\delta \leq 0.15$ . Further, it is assumed that the conversion factor is expressed by

$$\gamma = f(\log t)/f(\log t_0) = a - b \log t \quad \text{with } t_0 = 10^{-1} \text{h (6 min)}$$

and  $t = 10^5 \text{h}$ , that is  $\gamma_5 = f(5)/f(-1)$ .

SELECTION OF WOOD FOR TESTING OF JOINTS

1. Wood species The rules primarily apply to European pine and spruce.

2. Density

2.1 Two levels of density are defined: Low density and high density.

Note. If characteristic properties are to be applied to joints of wood which is not graded according to density (or elasticity modulus), normally only the low density level shall be considered.

2.2 Two methods of selecting wood are defined:

2.2.1 Method A The timber is selected in accordance with the following density requirements:

<u>Low density</u>	Mean value	$D_{om} \leq 400 \text{ kg/m}^3$
At least 1/5 of the pieces		$D_o \leq 350 \text{ kg/m}^3$

<u>High density</u>	Mean value	$D_{om} \leq 500 \text{ kg/m}^3$
At least 1/5 of the pieces		$D_o \leq 430 \text{ kg/m}^3$

Method B The timber is selected for smallest possible deviation of density with the following mean values:

<u>Low density</u>	$D_{om} \approx 400 \pm 40 \text{ kg/m}^3$
<u>High density</u>	$D_{om} \approx 500 \pm 50 \text{ kg/m}^3$

3. Knots The timber shall be free from knots in those parts which may influence the load-carrying capacity of the fastener.

CIB-W18 June 1976 MJ

Examples of evaluation of strength values from test results - mechanical timber joints.

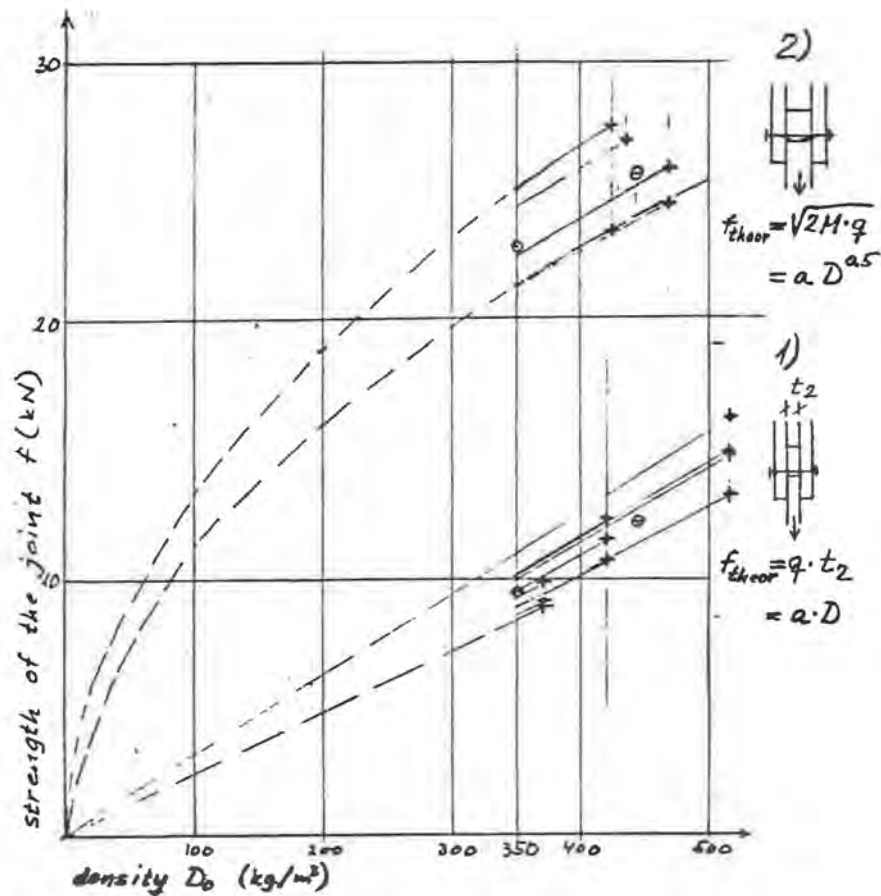

1)

No.	$f_{max}$ kN	$D_0$ kg/m³	$\psi$ %	$f'$ kN
T1/1	12,25	421	15,9	10,18
2	11,50	421	16,1	9,56
3	9,95	372	15,7	9,36
4	16,20	516	15,9	10,99
5	14,85	516	15,9	10,07
6	9,10	372	15,8	8,56
7	10,70	421	16,7	8,90
8	13,60	516	16,1	9,22
9	8,90	372	16,1	8,37
10	14,90	516	16,7	10,11
$\bar{x}$	12,20	444	16,1	9,53
$s$	2,59	64,9	0,35	0,82
$v\%$	21,3	14,6	2,16	8,56

$$f' = f \left( \frac{350}{D} \right)^c$$

$$c = 1$$

$$f_k = \bar{F}' (1 - C \cdot v) / \left( 2 - \frac{\psi}{15} \right)$$

$$n = 10 \Rightarrow C = 2,1$$

$$f_k = 9,53 (1 - 2,1 \cdot 0,0856) / \left( 2 - \frac{16,1}{15} \right)$$

$$f_k = 8,44 \text{ kN}$$

2)

No.	$f_{max}$ kN	$D_0$ kg/m³	$\psi$ %	$f'$ kN
T5/1	23,30	424	16,0	21,17
2	27,55	424	16,0	25,03
3	26,95	436	15,9	24,15
4	24,30	419	16,2	20,99
5	25,90	469	16,2	22,37
$\bar{x}$	25,60	444	16,1	22,74
$s$	1,78	23,0	0,13	1,80
$v\%$	6,96	5,17	0,84	7,90

$$f' = f \left( \frac{350}{D} \right)^c$$

$$c = 0,5$$

$$f_k = \bar{F}' (1 - C \cdot v) / \left( 2 - \frac{\psi}{15} \right)^c$$

$$n = 5 \Rightarrow C = 2,5$$

$$f_k = 22,74 (1 - 2,5 \cdot 0,079) / \left( 2 - \frac{16,1}{15} \right)^{0,5}$$

$$f_k = 18,96 \text{ kN}$$

INTERNATIONAL COUNCIL FOR BUILDING RESEARCH STUDIES AND DOCUMENTATION  
WORKING COMMISSION W18 - TIMBER STRUCTURES

COMMENTS TO RULES FOR TESTING TIMBER JOINTS AND DERIVATION OF  
CHARACTERISTIC VALUES FOR RIGIDITY AND STRENGTH

by

B NORÉN  
Swedish Forest Products Research Laboratory  
Stockholm  
Sweden

---

Aalborg, Denmark - June 1976



## COMMENTS TO RULES FOR TESTING TIMBER JOINTS AND DERIVATION OF CHARACTERISTIC VALUES FOR RIGIDITY AND STRENGTH

### Background

The load carrying capacity of mechanical fasteners for timber joints will be presented by characteristic values for rigidity (or compliance) and ultimate strength as a supplement to the code of practice for timber structures. Design values for the resistance are finally achieved as the characteristic values are multiplied by a transforming factor ( $\beta$ ) and divided by a safety factor ( $\gamma_m$ ). The factor  $\gamma_m$  will possibly consist of partial safety factors ( $\gamma_m = \gamma_{m1} \cdot \gamma_{m2} \cdot \dots \cdot \gamma_{mn}$ ), with reference to various parameters such as variability and control as well as structural safety class. The  $\gamma_m$  values will appear in the code of practice for timber structures but should be evaluated in accordance with rules for building material and components in general. For example, we may assume a general safety code to tell us how the value of  $\gamma_m$  is influenced by the choice of fractile value as characteristic value and how  $\gamma_m$  is influenced by the size and shape of the resistance deviation. Therefore the tests must provide us with results from which fractile values can be derived, usually the 5 percentile and the mean value, preferably also parameters to describe the shape of the frequency curve.

### Code sections

Unambiguous characteristic values demand specifications with reference to different conditions:

- A Definition of the population to which the values are supposed to apply. This implies the definition of the material - wood and fastener.
- B Definition of the type of structures to which the values apply. This includes definition of the effect (stresses) of the action for which characteristic resistance is given.
- C Definition of other conditions to which the values apply including definition of actions such as type of load and climate.

- AA Part of the population (A), possibly substitute for the population.
- BB Substitute for structural type and dimensions and for stresses.
- CC Substitute for action and climate.
- D Sampling (method and number) and storing of samples.
- E Preparation of test specimens from samples (selection, geometry, number).
- F Storing of test specimens.
- G Testing, including testing of control specimens for reference. (Loading and measuring method, testing climate.)
- H Presentation of test results.
- I Evaluation of properties of the population from the test results.

The last section (I) is the final aim of the preceding section. All sections can be laid down in codes. On account of their different nature, e.g. some being dependent on material and object, some more generally applicable, it is practical and common that they are grouped into different rules and standards. This is partly for administrative reason and different solutions exist. The following suggestion should agree with nordic practice:

Sections E, F, G and H are generally referred to a testing standard. In itself the standard is tied to its object but can, of course, in certain parts refer to exterior, more general standards.

Section D is generally not included in the testing standard. But it is a common important part of rules for verification of resistance by testing (design by testing) and in rules for quality control. These rules are partly tied to object, partly connected with the rules for evaluation (I).

The purpose of the testing is given in A, B and C in the first place. In principle, the kind of definitions mentioned in these sections should appear in building codes, such as the general design code (safety code) and the code for timber structures, but may also refer to independent descriptions of products. However, in many respects definitions of material, actions and climate are not yet complete in codes and recommendations. It may also be difficult to define reality, hence substitute populations and conditions must be defined, here denoted AA, BB and CC. A typical A and AA matter is the selection of timber for joints to be tested in order to determine the characteristic strength values. A B and BB matter is the limitation of loading cases at testing against the desired wide applicability of the characteristic values, for example, to describe resistance at combined actions. An important C and CC matter is how to choose testing climate.

Briefly, it is the sections A, B and C (AA, BB, and CC) which are principally decisive for the selection of material and the scope of the testing. The number of samples and test specimens is, however, stretchable within the limits set by the method of evaluation (I).

The rules of the final section (I) for evaluation the characteristic values from the results of the tests are necessary because the sampling according to D and the testing method according to E, F, G do not respond entirely to the conditions of the sections A, B and C or even AA, BB, CC. For the evaluation random as well as systematic variations must be considered. The casual deviation as a rule is generated by the sampling, that is, the properties of samples vary, while the properties of the design population are constant. The level of confidence for the estimation of the properties of the population is given by the general safety code, for example, the probability 0.75 that a characteristic strength value for the population, as judged from the sample, is lower than the real value. The method used for the evaluation should be in conformity with established statistical theory but must not be prescribed in detail in the code. But it is desirable that approved methods are mentioned, methods that can be "distribution-free" or methods linked to certain functions to substitute the real distribution of the property in question, such as the normal distribution. Recommendations of that kind may essentially be the same for all materials and structural components.

Casual variation in the result is also introduced by the method of selecting test specimens from the samples and by imperfections in the testing itself and the conditions (climate) at which it is carried out. This part of the variation, to the extent it can be separated, may be considered either when the testing results are presented (H) or be treated supplementary to the evaluation of the results (I).

At systematic deviations the results measured at standard testing conditions must be transformed to those conditions to which the characteristic properties of the population shall apply. By conditions is here meant everything that is defined in the sections A, B and C. Of principal importance in testing wood constructions are the wood properties (for mechanical joints density), climate (moisture content of the wood) and duration of stress. Direction of the force with respect to fibres may also be mentioned. In a simple case reference can be made to the transforming factors established in the timber structural code. In other cases special transforming factors are based on theory of performance or on performance testing. The presentation of these factors is part of the documentation of properties.

CIB recommendations for timber joints

The purpose of the CIB proposals concerning testing and evaluation recommendations for mechanical timber joints is to achieve international basic values for properties and to make duplicate testing in several countries uncalled for. This is an old request which has been stressed by the introduction on the market of the nail plates. At present these plates are tested repeatedly and assigned different strength values in different countries. Actually, international rules of this kind are a necessary basis for an international code for the design of structures.

A working hypothesis is that there will be (1) general testing rules for mechanical timber joints, (2) specific testing rules for different kinds of fasteners, (3) special rules for joints to and between panel material of wood and for joints between wood and other material (steel, concrete), (4) rules for evaluating of the characteristic load-carrying capacity of mechanical timber joints.



In (1) principles for selection of wood for the joints to be tested can be included, see appendix 1. In this way at least some recommendations for sampling (D) are introduced in the testing rules. Apart from that the general testing rules will include what is common for mechanical joints with different kinds of fasteners, compare RILEM-3TT 5th draft, August 1975 (CIB-W18/57-2, Karlsruhe October 1975). The specific testing rules (2) and (3) will appear gradually, the first dealing with nail plates.

Appendix 1      Selections of wood for testing of joints

Appendix 2      Check on the long term factor in testing timber joints

## SELECTION OF WOOD FOR TESTING OF JOINTS

1. Wood species The rules primarily apply to European pine and spruce.

2. Density

2.1 Two levels of density are defined: Low density and high density.

Note. If characteristic properties are to be applied to joints of wood which is not graded according to density (or elasticity modulus), normally only the low density level shall be considered.

2.2 Two methods of selecting wood are defined:

2.2.1 Method A The timber is selected in accordance with the following density requirements:

<u>Low density</u>	Mean value	$D_{om} \leq 400 \text{ kg/m}^3$
At least 1/5 of the pieces		$D_o \leq 350 \text{ kg/m}^3$

<u>High density</u>	Mean value	$D_{om} \leq 500 \text{ kg/m}^3$
At least 1/5 of the pieces		$D_o \leq 430 \text{ kg/m}^3$

Method B The timber is selected for smallest possible deviation of density with the following mean values:

<u>Low density</u>	$D_{om} \approx 400 \pm 40 \text{ kg/m}^3$
<u>High density</u>	$D_{om} \approx 500 \pm 50 \text{ kg/m}^3$

3. Knots The timber shall be free from knots in those parts which may influence the load-carrying capacity of the fastener.



### CHECK ON THE LONG TERM FACTOR IN TESTING TIMBER JOINTS

It is here assumed that the relation between the constant stress ( $f$ ) and the time to failure ( $t$ ) can be expressed by

$$\frac{f(\log t)}{f(\log t_0)} = a - b \log t \quad (1)$$

If the values of  $a$  and  $b$  as well as the distribution of  $f(\log t)$  are known, one can calculate the probability that the joint will not fail at a certain level and duration of load. In the following example it is assumed that  $a = 14/15$  and  $b = 1/15$  when  $t$  is expressed in hours. We then have

$$f(\log t) = \left(1 - \frac{1 + \log t}{15}\right) \cdot f(\log t_0) = \psi f(\log t_0) \quad (2)$$

$f(\log t_0)$  can be regarded as the short-term strength and  $f(\log t)$  as the long-term strength. Hence,  $\psi$  is the conversion factor for long-term loading. If the short term testing time is estimated to  $t_0 = 10^{-1}$  h (6 min) and "long term" is defined by  $t = 10^5$  h, the long-term conversion factor according to (2) will be  $9/15 = 0.6$ . For every decade of time the decrement of strength is  $1/15$  of the short-term strength  $f(-1)$ . If  $f$  is normally distributed with a constant coefficient of variation  $\delta = 0.15$ , a joint with a strength equal to the mean ( $f = f_m$ ) will loose  $1/2.25 = 0.444$  times the standard deviation of  $f(-1)$  per decade:

$$\frac{1}{2.25} \cdot 0.15 f_m(-1) = \frac{1}{15} f_m(-1) \quad (3)$$

If the strength deviation is small compared with the reduction due to time, one could at this stage introduce the approximation that the strength decrement is constant for all  $f$ -values, not relative as shown in (2).

Thus (2) is replaced by

$$f(\log t_0) - f(\log t) = \frac{1 + \log t}{15} f_m(\log t) \quad (4)$$

The calculation of the probability that the tested joints resist the duration of the load will then be very simple. (The result is given in table 1.)

As seen in figure 1 a test joint with a strength  $f_m(-1)$  will resist the stress  $0.933 f_m(-1)$  in just 1h. Thus, if all the test joints are loaded to this stress 50 % will fail before 1h. If the load instead is  $0.866 f_m(-1)$  50 % will resist 10h load, etc. There will be no difference in this result if we use the more realistic time influence according to (2) with a strength decrement proportional to  $f$ . But we will get a slight difference in the probability of resistance when the strength deviates from the mean. If a joint with the strength  $1.066 f_m(-1)$  is loaded by  $1.0 f_m(-1)$  it will resist not quite 1h but 0.866 h, compare the intersection between the broken line in figure 1 and  $\sigma = f_m(-1)$ . For 1h resistance a slightly higher relative short-term strength than 1.066 is required:

$$\frac{f(-1)}{f_m(-1)} = \frac{1}{1 - \frac{1 + \log t}{15}} = \frac{15}{14} = 1.0714 = 1 + 0.476 s \quad (5)$$

$s$  = standard deviation of  $f$

This means that the value 32.9 in table 1, as the number of joints which resist stress equal to the mean strength, decreases to 31.7. If the load is decreased to  $0.8 f_m(-1)$  all joints with the relative strength of at least  $0.8 \cdot 1.0714 = 1 - 0.939s$  will resist the load 1h. In this case the absolute decrement of  $s$  per decade is less than that of the mean so a few more joints than expected from the approximate calculation (4) will be intact after 1h (82.7 instead of 81.3 percent, see the table).

The suggestion in the paper CIB-W18/5-7-3 by Kuipers that "from the total number of  $0.80\bar{F}$  long duration tests not more than 50 % shall be collapsed within a period of 100h" is in agreement with the values of the table.

TABLE 1 Number of joints of 100 tested which do not fail after time  $t$  of constant stress. Coefficient of variation  $\delta(f) = 0.15$ . Time influence according to equation (4) respectively (2).

Stress	Time (h) $\rightarrow$	$10^{-1}$	1	10	$10^2$	$10^3$	$10^4$	$10^5$	Eq.
$1.0 \times f_m(-1)$		50	32.9	18.7	9.1	3.7	1.3	0.4	(4)
		50	31.9	15.3	4.8	0.8	0.0	0.0	(2)
0.933..		67.1	50	32.9	18.7	9.1	3.7	1.3	(4)
0.866..		81.3	67.1	50	32.9	18.7	9.1	3.7	(4)
0.8		90.9	81.3	67.1	50	32.9	18.7	9.1	(4)
		90.9	82.7	69.6	50	27.2	9.1	1.3	(2)
0.733..		96.3	90.9	81.3	67.1	50	32.9	18.7	(4)
0.666..		98.7	96.3	90.9	81.3	67.1	50	32.9	(4)
$0.6 \times f_m(-1)$		99.6	98.7	96.3	90.9	81.3	67.1	50	(4)
		99.6	99.1	98.0	95.2	88.7	74.7	50	(2)



INTERNATIONAL COUNCIL FOR BUILDING RESEARCH STUDIES AND DOCUMENTATION  
WORKING COMMISSION W18 - TIMBER STRUCTURES

LONG-TERM LOADING FOR THE CODE OF PRACTICE  
(Part 2)

by

B NORÉN  
Swedish Forest Products Research Laboratory  
Stockholm  
Sweden

Aalborg, Denmark - June 1976

## LONG-TERM LOADING FOR THE CODE OF PRACTICE (PART 2)

B Norén - Swedish Forest Products Research Laboratory, Stockholm, Sweden

### Introduction

This paper is a sequel to the paper "Definitions of long-term loading for the Code of Practice", /1/ presented for the CIB Working Commission W 18 in Delft, June 1974 1:1. It originates in substance from a comment by the author on the NKB proposal for Safety on Loading Codes /2/ (presented to the W 18 in Paris, February 1975).

### Deformation

The deformation is generally important for the serviceability state but in many structures indirectly also for the ultimate state. As shown by eq. (5) in /1/

$$\epsilon(q,t) = \epsilon(\bar{q},LT) + \epsilon(q-\bar{q},ST)$$

the creep at variable load can be calculated as a total of long-term (LT) creep, caused by the mean intensity of the load ( $\bar{q}$ ), and short-term (ST) creep, caused by a load with an intensity equal to the differences of the maximum ( $q$ ) and the mean value ( $\bar{q}$ ). The code must give the creep function ( $\phi$ ), possibly in terms of fictive MOE for varying duration;  $E_{\phi} = E/(1+\phi)$ . Several codes already specify such fictive moduli, including slip moduli for joints.

### Ultimate load

The influence of time on strength of material - or rather - the influence of stress on time to failure, is generally expressed by a straight line in a semi-logarithmic diagram (or by a flat hyperbolic curve approaching such a line). This does of course not imply that the relation can be represented by the same line for all structures built of the material.

The dotted line in Figure 1 indicates a case where a load  $p = 1$  makes the material or structure fail in 5 min, while a load  $p = 9/16$  can rest for 50 a without causing failure. The full line in Figure 1

$$p_B/p_0 = 1 - 0.08 \log t \quad (1)$$

gives a slightly larger influence of stress on time to failure, or - expressed the other way round - a slightly lower long-term strength. The line is drawn with reference to the strength reduction factors given by the Swedish code (SBN 1975) for structural timber at normal load and exceptional load and an estimation of the total duration of these loads.

The following calculations are based on the SBN-line in Figure 1, merely as an illustration. Neither of the lines can represent all cases. As demonstrated by Borg Madsen's tests they do not even describe correctly the time influence on the strength of structural timber of all grades.

#### Strength conversion

According to the NKB-proposal the loads are graded in classes with respect to the time of continuous loading /2/, cf. Appendix 1 to /1/. The Class A loads who have a lower limit of continuous loading of 250 d, are generally considered as constant (dead) loads. Still they may not appear each year. For a constant load the usual method of applying a long-term factor on the characteristic strength is the simplest. If the service life of the structure is expected to be 30 years, the SBN-line gives the long-term strength

$$m_{k30} = 0.56 m_{k0} \quad (\approx 0.6 m_{k0}) \quad (2)$$

where  $m_{k0}$  is the strength at short-term testing.

In practice, however, the constant load, is almost always superimposed by one or several loads with less duration than 250 d, in the NKB-proposal referred to as B, C and D loads. Also in this case one method is to calculate a characteristic strength value, weighted with respect to the duration

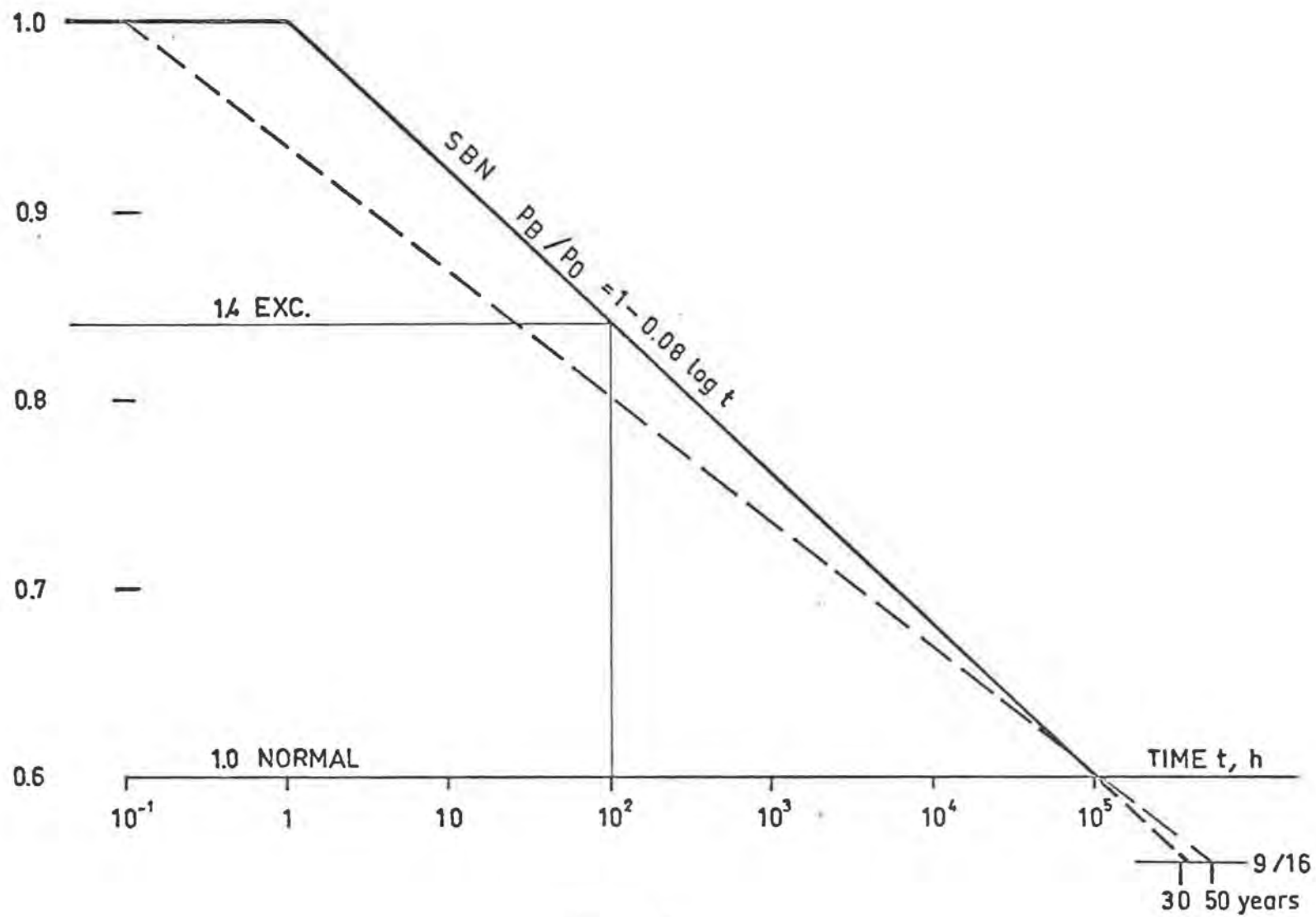

Figure 1

of the various loads:

$$m'_k = \frac{p_A + b p_B + c p_C}{p_A + p_B + p_C} \cdot 0.6 m_{k0} \quad (3)$$

For the Stockholm area the characteristic value of exceptional snow load is supposed to be 2 kPa. This value is defined by the probability  $P = 0.02$  that it is exceeded at least once during the year. Snow load belongs to the duration-class B, the lower limit of continuous loading being 15 h and the upper limit 250 d. Assume it is 10 d and that the characteristic value is exceeded at only one occasion during one and the same year. This should give us a relative duration of

$$\eta = 0.02 \cdot 10/365 = 0.00055$$

According to the NKB-proposal it is sufficient to use the value 0.0005. The total duration for a service time of 30 a is thus

$$0.0005 \cdot 30 \cdot 365 \cdot 24 = 131 \text{ h}$$

If eq. (1) is applied we have

$$p_B/p_0 = 1 - 0.08 \log 131 = 0.83$$

We should then use  $b = 0.83/0.6 = 1.4$  in (3). The b-values for other type of loads and the c-values can be calculated correspondingly.

The strength conversion method was used in the former Danish Standard DS 413 (1968).

#### Load conversion

Another method of considering varying loads is to convert them into constant loads which after a certain time  $T$  give the same reduction of strength as the loads do which have a total duration less than  $T$ . The mean curves of

duration for a year is assumed to be available for different types of load. Each such curve can be differentiated as shown in Table 1.

TABLE 1

$\Delta p$	$\eta$	Total duration
$p_1$	$\eta_1$	$\eta_1 T$
$p_2 - p_1$	$\eta_2$	$\eta_2 T$
$p_3 - p_2$	$\eta_3$	$\eta_3 T$

For each division of the load ( $\Delta p$ ) the equivalent load ( $\Delta p_e$ ) for a duration  $T$  can be calculated. A favourable case is when the law of superposition can be applied. As shown in /1/ we then have  $\Delta p_e = \eta \Delta p$ , i.e. the varying load can be replaced by a constant load

$$p_e = \bar{p} = \sum \eta \Delta p \quad (4)$$

In a less favourable case there is no creep recovery when the load is removed. (The "strength reduction" is assumed to be caused by the creep). The division of load,  $\Delta p$ , with the relative duration  $\eta$ , can then be replaced by a load  $\Delta p'_e$ , giving the same reduction of  $p_B$  during the time  $T$  as  $\Delta p$  gives at a duration  $\eta T$ , see /1/. It is obvious from Figure 1 that  $\Delta p'_e$  is not much smaller than  $\Delta p$ , should not  $\eta$  be comparatively small. This is of course due to the logarithmic time scale.

In Table 2 the constant loads  $p_e$  respectively  $p'_e$  are calculated, which for the two types of creep are equivalent to a load distributed as shown in Figure 2. The curve is approximated into four steps and the SBN-line in Figure 1 is applied.

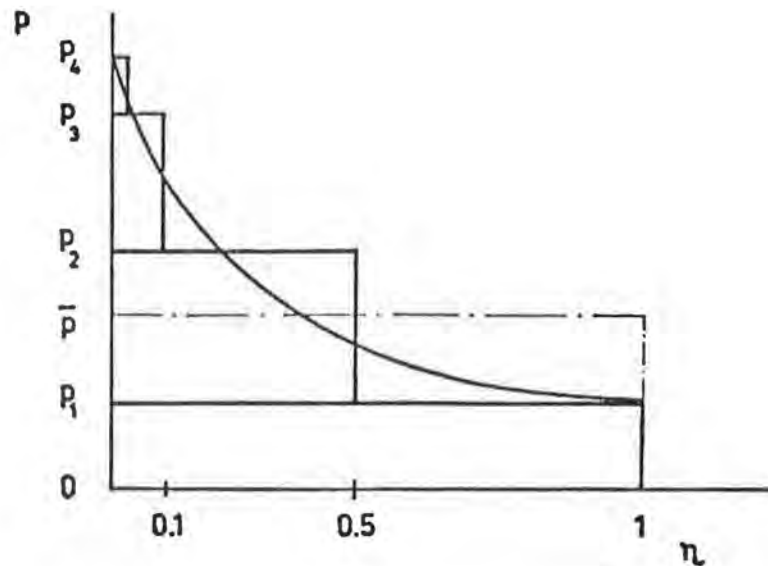

Figure 1

TABLE 2

$\Delta p$	$n$	$n \Delta p$	$0.08 \log 1/n$	$\frac{0.6}{0.6+(4)}$	(1)(5)
1	2	3	4	5	6
2	1	2	0	1	2
4	0.5	2	0.024	0.96	3.83
4	0.1	0.4	0.08	0.88	3.53
2	0.01	0.02	0.16	0.79	1.58
$P_4=12$	$p_e = \bar{p} = 4.42$			$p'_e = 10.9$	

The load with the intensity  $2 + 4 + 4 = 10$  has a total duration over 30 years of  $0.1 \cdot 30 \cdot 365 \cdot 24 = 2.62 \cdot 10^4$ h and should according to the Swedish code (SBN 1975) be referred to as a normal load (total duration  $10^4$  à  $10^5$ h) for which the long-term factor 0.6 must be applied. Hence, the value  $p_e = 4.42$  would be favourable while the value  $p'_e = 10.9$  would

be slightly unfavourable compared with the value 10. (A compromise based on 50% elastic creep and 50% not recovering creep should give a value  $p_e \approx 7.5$ ).

The design criterion of the method with partial coefficients is

$$\sum \gamma_p p_k \leq m_k / \gamma_m \quad (5)$$

or after the load conversion described

$$\sum \gamma_p p_e \leq m_{kT} / \gamma_m \quad (5a)$$

In the example the  $p_e$  were referred to  $T = LT$  corresponding to a long-term strength reducing factor 0.6. (It could alternatively have been referred to  $T = ST$  corresponding to a factor 1.0). Observe though that the condition (5a) has to be checked for short-term loading as well. For example in Figure 2 the total duration of the load  $p_4$  over one year is  $0.01 \cdot 8760 = 87.6 \text{ h} \approx 10^2 \text{ h}$ . If this also is the continuous time of loading, then it is seen from Figure 1 that  $p_4$  will be the determining load if  $p_4 / p_{LT} > 1.4$ . This will obviously be so for  $p_4 / p_e = 12 / 4.42$  but not for  $p_4 / p'_e = 12 / 10.9$ .

However, Figure 2 was supposed to give the mean annual load distribution. The characteristic value of  $p_4$  given in the code will probably be higher. Let say it is 30% higher, and defined by the probability  $\underline{p} = 0.02$  that it is exceeded during a year. Hence  $p_{4k} / p_e = 1.30 \cdot 12 / 10.9 = 1.43$  and the short-term load is just about determining the design.

#### Conversion of characteristic load values

Present codes or code proposals do not give load-duration distribution curves, neither mean curves nor the variation between years. Hence, the calculation of equivalent constant loads ( $p_e$  and  $p'_e$ ) must for the time being be based on characteristic values and the corresponding duration values possibly given in the loading code and on some rough assumption for the duration curve. It is then a step forward when not only one characteristic value of the load of a certain type is

given. In the NKB-proposal /2/ there are for example two characteristic snow-loads given, see Table 3. Naturally, there is no constant snow-load (but it could have been added an extreme value). In order to calculate the equivalent constant long-term load one might for example accept the following assumptions:

1. The long-term effect of the exceptional load is neglected (the  $q_k$ -value 1.5 is exceeded one year of 50).
2. The mean term when there is some snow is 4 months.
3. The mean annual duration of the normal characteristic value  $q_k = 1.0$ , which according to Table 3 is  $0.015 \cdot 8760 = 131$  h, is approximated to zero.
4. The duration curve is a straight line.

TABLE 3

	$q_k$	$\eta$	$t_{qs}$	P
Normal	1.0	0.015	B	0.2
Exceptional	1.5	0.0005	B	0.02

Thus the calculation is based on the distribution shown in Figure 3 and on Figure 1, which gives

$$q_e = \bar{q} = 0.5/3 = 0.167 \quad (\text{kPa})$$

$$q'_e = \frac{0.6 \cdot 1.0}{t_0} \int_1^{t_0} \frac{dt}{1 - 0.08 \log t} \approx 0.9$$

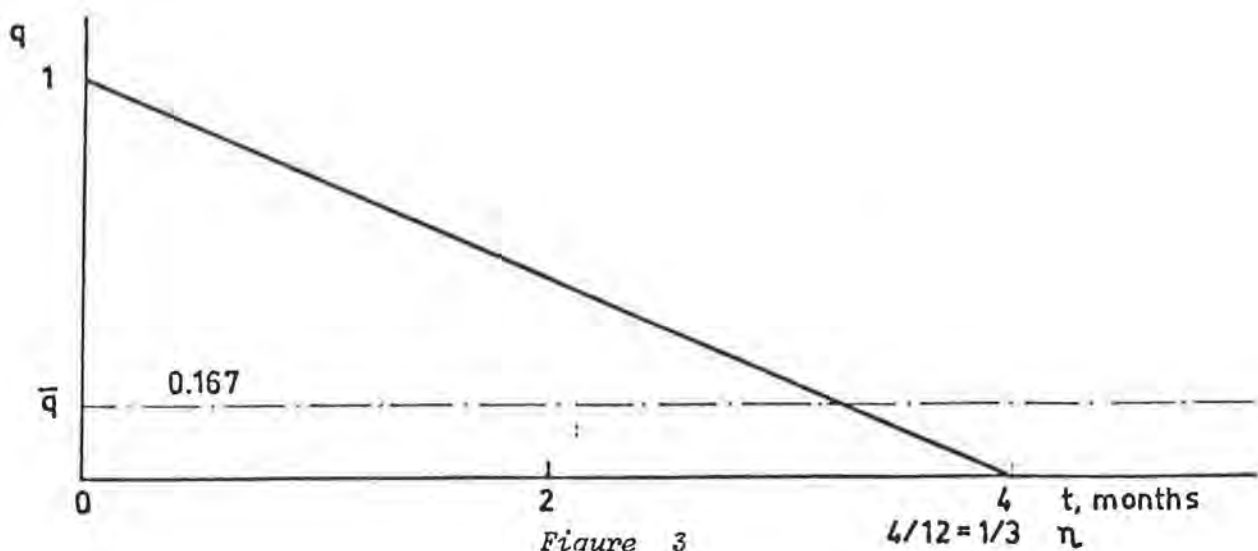

If then a fifth assumption is added:

5. One third of the creep is elastic, two thirds irrecoverable  
we finally get

$$q_e = 1/3 \cdot 0.167 + 2/3 \cdot 0.90 = 0.65$$

i.e. the long-term influence of the snow-load should be checked by assuming the characteristic normal snow-load reduced by 1/3 to act as constant load.



INTERNATIONAL COUNCIL FOR BUILDING RESEARCH STUDIES AND DOCUMENTATION

WORKING COMMISSION W18 - TIMBER STRUCTURES

LONG TERM LOADING

by

K MOHLER  
Universität Karlsruhe  
Federal Republic of Germany

Aalborg, Denmark - June 1976

Long-Term-Loading

Federal Republic of Germany - K Mähler, Karlsruhe

Long-term loading according to the timber construction specifications

In DIN 1052 permissible stresses for wood and wood-based panel products and also permissible fastener loadings are indicated for the principal loads, which comprise dead, live and snow loads. The permissible values may be increased by 15 per cent. if additional loads (wind loads, inertia forces and horizontal lateral forces e.g. of cranes) also occur. If only additional loads occur, the largest of them is to be regarded as the principal load.

The timber structures, that have hitherto been mostly used in building construction, are roof structures and floors which are permanently subjected to a relatively low dead load due to the inherent weight of the members of which they are constructed and the roof skin (floor structure) and are also liable to be subjected to snow loads, which, though substantial, are of relatively short duration. Wind loads on the principal members are usually low and only of short duration, so that increasing the permissible stress seemed justified. Since the data of tests and investigations performed by the author about 8 years ago were not available, it was decided to increase the permissible stress by 15 %, this being the percentage which is recommended in specifications relating to the design of structural steelwork, and which has been shown by non-German investigations and dynamic loading studies to be reasonable for timber bridge structures.

A study in depth of the "strength after subjection to loading for a specified time and the load-carrying capacity under long-term loading" has recently been carried out, the results of which it is intended to take into account when preparing a new version of the timber construction specifications.

The strowing of flat roofs with gravel, a practice that has often been adopted in recent years, thereby increasing the dead load, has shown that the static elastic modulus values, as specified in DIN 1052, fail to account with sufficient accuracy for the deflections that occur after a considerable length of time. For this reason

In the explanatory notes (1) to DIN 1052 a reduction of not less than 25 % was proposed for the  $E_f$  and  $G_f$ -values, if the dead loads are greater than the combined live and snow loads. Furthermore, an attempt has been made to allow for the long-term effect (creep) by adding to the specifications on the deflection analysis (taking into account the shear deformation, deflection restriction for overall load and not merely live load) and on the necessary camber of the timber structures.

Creep effects must also be taken into account where fasteners are concerned.

In this connection a study by Hotter (2) shows that these may give rise to substantial redistributions of internal forces and moments particularly in statically indeterminate systems. With flexibly connected bracing and panels (or forms) which are used for stiffening compression chords against buckling, the stability of such structures greatly depends on the rigidity of the fasteners (Möhler (3); Möhler-Schelling (4); Brüninghoff (5)).

- (1) Möhler, K.: Specifications. Timber construction pocketbook, 7th edition 1974, p.683.
- (2) Hotter, K.: Analysis of timber structures for long-term loading with particular reference to joint rigidities  
Die Bautechnik 1973 50, 239-47 and 272-5
- (3) Möhler, K.: On the load-carrying capacity of flexural beams and compression members with compound sections and flexible fasteners.  
Thesis Techn. Hochschule, Karlsruhe 1956
- (4) Möhler, K &  
Schelling On the design of bracing and stiffeners to increase resistance to buckling in timber construction. Der Bauingenieur 1968 43, 43-5
- (5) Brüninghoff, H.: Stresses and stability in transversely supported board-layer beams. Thesis (Univ.) (Techn. Hochschule) Karlsruhe, 1972

## 2 Long-term loading tests

Long-term loading tests on ~~solid~~<sup>Solid</sup> wood and wood-based panel products (plywood and wood particle board) have been in progress at Karlsruhe since 1969.

Reports have

~~already~~ already been published on some of the tests :

- (1) Mähler, K and  
J Ehlbeck : Tests on the behaviour of particle board and plywood under long-term flexural loading  
Holz als Roh- und Werkstoff 1968 26, 118-24
- (2) Ditto : Short-term and long-term tests to determine the static bending strength and load-carrying capacity under long-term loading respectively of plywood for construction purposes.  
In : Berichte aus der Bauforschung No.29, p.1-33  
published by Wilhelm Ernst u. Sohn, Berlin 1974
- (3) Mähler, K and  
G Maier : Creep and relaxation behaviour of air-dry and wet spruce in compression perpendicular to the grain  
Holz als Roh- und Werkstoff 1970 28 (1), 14-20.

The following studies are currently in progress or being evaluated :

1 Tension, compression and bending tests on spruce test pieces

1.1 Constant loading at 85 to 10 % of the static strength.

Result of the bending tests up to 1000 days :

a) Strength at a specified time :

$$\sigma_t = \sigma_0 (0.7724 - 0.0622 \log t)$$

where  $t$  = time in days,  $\sigma_0$  = static strength

$$\sigma_{1000} = 0.58 \sigma_0$$

b)  $E_t/E_0$  - variation thereof when the growth rings are horizontal or vertical.

After 1000 days :  $E_{1000} \approx 0.56 E_0$  (horizontal rings)

$E_{1000} \approx 0.67 E_0$  (vertical growth rings)

The time dependence of  $E_t/E_0$  is shown for the individual loading stages in the graphs accompanying this memorandum (enclosures 1 and 2).

1.2 Comparative bending tests at constant stress and with stress alternation at 7-day intervals between  $\sigma_{full}$  and  $0.5 \sigma_{full}$  (not yet concluded).

Result so far : alternating stress in range up to  $\sigma = 200 \text{ kgf/cm}^2$  has no effect.

1.3 Bending tests with test pieces continuous over two spans for checking the stress conditions in the support region (not yet concluded).

1.4 Bending tests on specimens with different l/h ratio for determining the shear creep (not yet concluded).

Result so far : creep much higher under shear loading than in bending.

2 Investigations of torsion specimens (not yet concluded)

Static torsional strength of spruce about 50 % higher than its shear strength.

### 2 enclosures

The long-term tests, which have so far been evaluated for an observation time of 400 days, give every expectation that the following relationships will be obtained :

a) Strength at a specified time :

$$\tau_t = 90.25 - 2.53 \log t$$

where t = time in hours

$$\tau_{1000 \text{ days}} = 0.88 \tau_0$$

$\tau_0$  = static torsional strength

According to this expression, the reduction in torsional strength under long-term loading appears to be much less than under flexural loading.

b)  $G_t/G_0$  - variation :

From the provisional evaluation was obtained :

$$G_t/G_0 = \frac{1}{1 + 0.2262 t^{0.272}}$$

where t = time in days ;  $G_0$  = static torsion modulus

$$G_{1000 \text{ days}} = 0.40 G_0$$

According to this expression, the torsion creep, like the shear creep, appears to be much higher than the bending creep.

2 Enclosures

BENDING TESTS

$E_t/E_0$  - time dependence : graph 1 for horizontal growth rings  
graph 2 for vertical growth rings

Key to German terms :

Versuche	= tests
Versuchswerte	= test values
Zeichen	= symbols
statische Biegefestigkeit	= static bending strength
Biegespannung beim L.	= bending stress in the long-term test
Belastungszeit in Tagen	= loading time in days
Kantholz bei etc.	= timbers at $\sigma = 10 \text{ N/mm}^2$

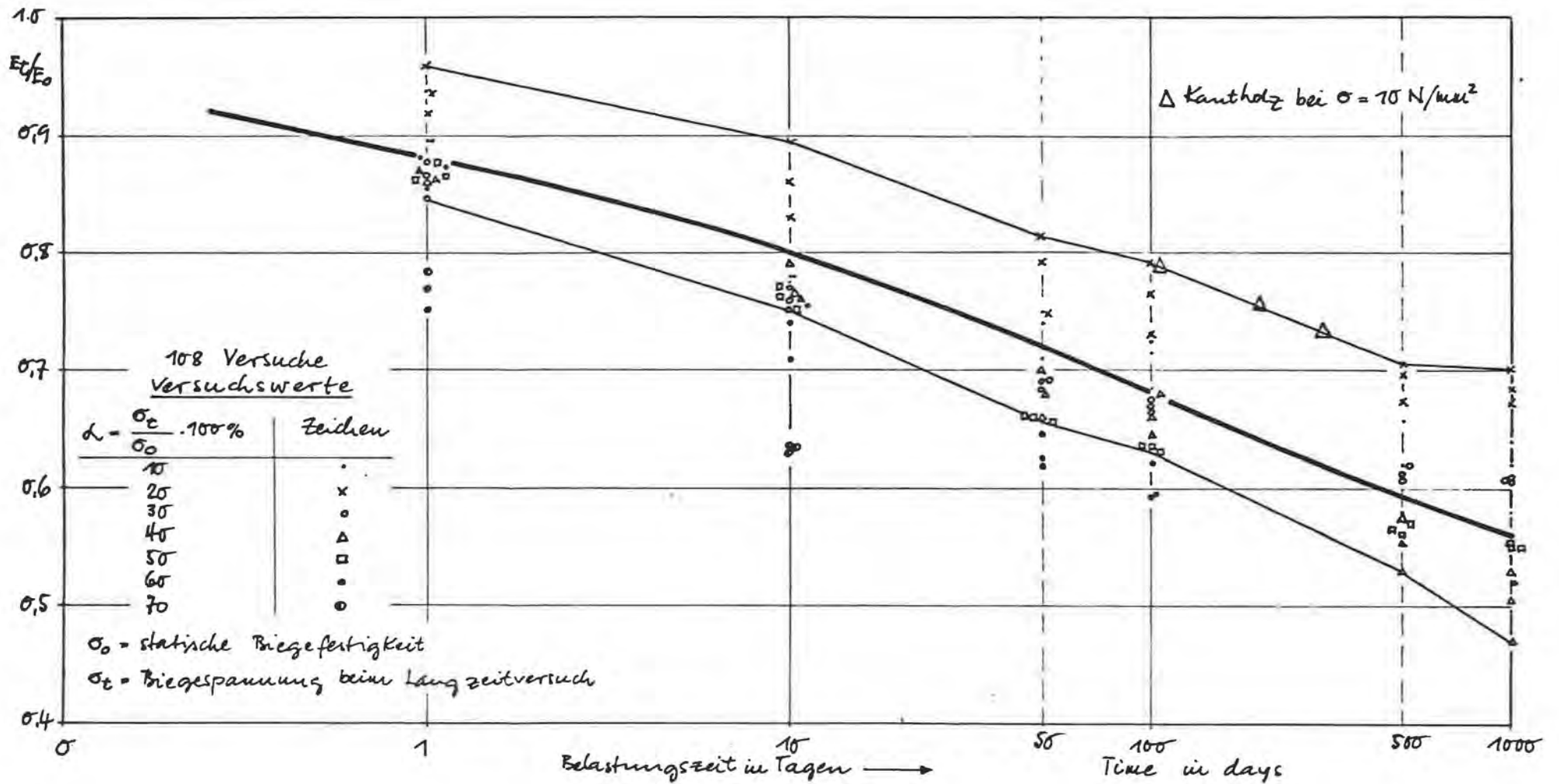

Biegeversuche  
 $E_t/E_0$  - Zeit - Abhängigkeit bei liegenden Jahrringen

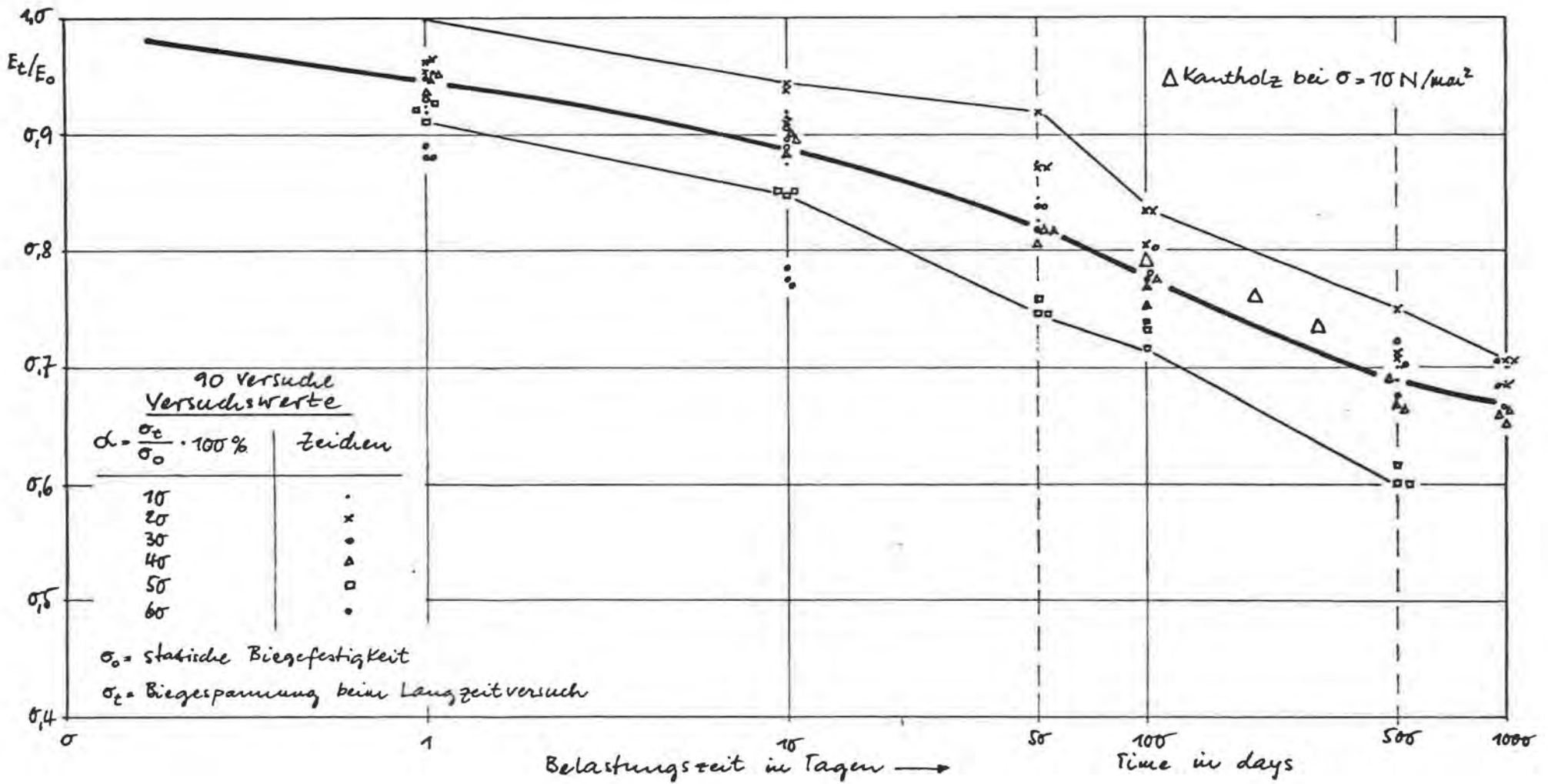

### Biegeversuche

$E_t/E_0$  - Zeit - Abhängigkeit bei stehenden Fahrriegen

INTERNATIONAL COUNCIL FOR BUILDING RESEARCH STUDIES AND DOCUMENTATION  
WORKING COMMISSION W18 - TIMBER STRUCTURES

DEFLECTION OF TRUSSED RAFTERS UNDER ALTERNATING LOADING DURING  
A YEAR

by

T FELDBORG and M JOHANSEN  
Building Research Institute  
Denmark

Aalborg, Denmark - June 1976

Deflection of trussed rafters under alternating loading during a year

T. Feldborg and M. Johansen, Building Research Institute, Denmark

Introduction

Trussed rafters are used in the greatest part of building in Denmark. Most of the trussed rafters are now factory made and connected by toothed metal plates, but also nailed connections are still used.

The common simple design calculations neglect the effect of rigidity and deformation of the joints. They therefore give a wrong picture of safety and deflections. It often results in bad utilization of the timber and sometimes in too great deflections of the trusses.

Therefore the Technical University and the Building Research Institute have started a research programme to form a basis for more accurate and economic calculations of trussed rafters.

At the Technical University Mr. A.R. Egerup has investigated the short-term stiffness and bearing capacity of 56 trussed rafters. At the Building Research Institute the short-term behavior of the neel joint and the lower chord splice are studied, and the long-term behavior of the trussed rafters will be studied within 5 years.

This report presents the results from one year during which the load has been alternating between dead load and dead load + design snow load.

Specimens

The long term investigation comprises 30 W-trussed rafters of the 3 types W1, W2, W3, shown in fig. 1.

Five different connection systems were used:

Connection system	Number of trussed rafters		
	W1	W2	W3
a) Hydro Nail plates both sides	6	2	2
b) TCT Roll-Loch plates both sides	2		
c) Nailed metal plates both sides	4	2	2
d) Nailed plywood gussets both sides	4	2	2
e) Metal plates between 2 boards nailed from one side	2		

The trussed rafters are made of visual graded structural timber of the lowest grade "U/K" (unclassified) according to the Danish Standard DS413. Two of the trussed rafters connected by Hydro Nail are designed for heavy

roof cladding, all others are designed for light roof cladding.

In the trussed rafters connected by system a-d, the dimensions of the lower chords and the web members are 45 x 95 mm, the dimensions of the upper chords are 45 x 120 mm (and 45 x 145 for heavy roof cladding).

Two trussed rafters have all members made of 2 boards nailed together and connected by metal plates between the boards and nailed from one side. The upper chords are double, 25 x 120, the lower chords and the web members are double, 25 x 95 mm.

The different joints are shown in fig. 2. The dimensions and modulus of elasticity of chord members are shown in table 1.

#### Experimental procedure

The trussed rafters are installed as roof construction in an open pole building, fig. 3. The building prevents rain and snow from falling on the trusses, while allowing them to be subjected to wind load on the roof and changes in temperature and relative humidity occurring during the study.

The wind load is unimportant at a roof slope of 1:3.

Lateral movement of the upper chords is restrained by 20 x 50 mm strips of wood, while the nailing strips for the roof sheets are cut between each pair of trusses, so that they can deflect almost independently.

The loading arrangement is shown in fig. 4.

The weights are suspended from cross beams supported on a pair of trussed rafters. The weights suspended from the lower chord represent the design load (ceiling + insulation) of  $0.3 \text{ kN/m}^2$  ( $0.3 \text{ kN/m}$  on a 1.0 m spacing).

The weights suspended from the upper chord + the roof cladding of aluminium sheets ( $0.03 \text{ kN/m}^2$ ) represent the design snow load  $0.75 \text{ kN/m}^2$  + design dead load.

One pair of trussed rafters connected by Hydro Nail plates are designed for a heavy roof cladding  $0.8 \text{ kN/m}^2$ .

Three pairs of trussed rafters connected by Hydro Nail, nailed metal plates and nailed plywood gussets are designed for a light roof cladding  $0.3 \text{ kN/m}^2$ , but they are overloaded by weights corresponding with the load of a heavy roof cladding  $0.8 \text{ kN/m}^2$ .

All the other trussed rafters are loaded by the design dead load  $0.3 \text{ kN/m}^2$  on the upper chord.

During the first year the load has been varied between 8 weeks dead load and 1 week dead load + design snow load.

Full design snow load is very rare in Denmark, and according to 30 years measuring the duration does not exceed 5 days. (During the first year there has been no snow).

Deflections of the trusses are being measured at the joints and at the middle of the members of the upper and lower chords with the aid of a levelling instrument.

Temperature and relative humidity are recorded and moisture contents are measured of 4 pieces about 0.5 m long cut of the timber used for the lower chords and placed between the trusses.

### Results

Fig. 5 shows how the load has been varied and how the temperature, relative humidity and moisture content happened to vary during the first year of the investigation. It shows when the deflections were measured in 15 points of each specimen: 1 day before and after the load has been altered. Fig. 6 shows how the deflections of truss no 10 and 15 increased. Measurement no 7 and no 29 are made when 1st and 6th snow load had acted 6 days.

Fig. 7 and 8 show the deflections of peak and midspan lower chord of truss no 10 and 15.

Fig. 9 shows the different deflection values at the end of first snow load for truss type W1 and W2 connected by the different connection systems

Table 2, 3 and 4 show the deflection values from measurement no 3, 7 and 29 of all the trusses. Truss no 13 and 20 are only loaded by the very light roof cladding.

Gaps (max 4 mm) between the upper chord members in the peak joints were closed before snow loading.

In heel joints and lower chord splice the following values were measured.

Truss no.	Connection system	Mutual displacement of heel joint at measurement no 25	Slip of the lower chord splice at measurement no.		
			6 one day snow load	7 6 days snow load	25 5 x 7 days snow load
14 + 15	a) Hydro N.	0.2 - 0.5	0.15 mm	0.17 mm	0.25 mm
3 + 4	b) TCT	1	0.33	0.40	0.57
5 + 6	c) 2 Metal pl.	1 - 2	0.67	0.75	0.92
9 + 10	d) Plywood	2 - 3	1.47	1.70	2.14
1 + 2	e) Metal pl.	0.5 - 1	0.48	0.56	0.67

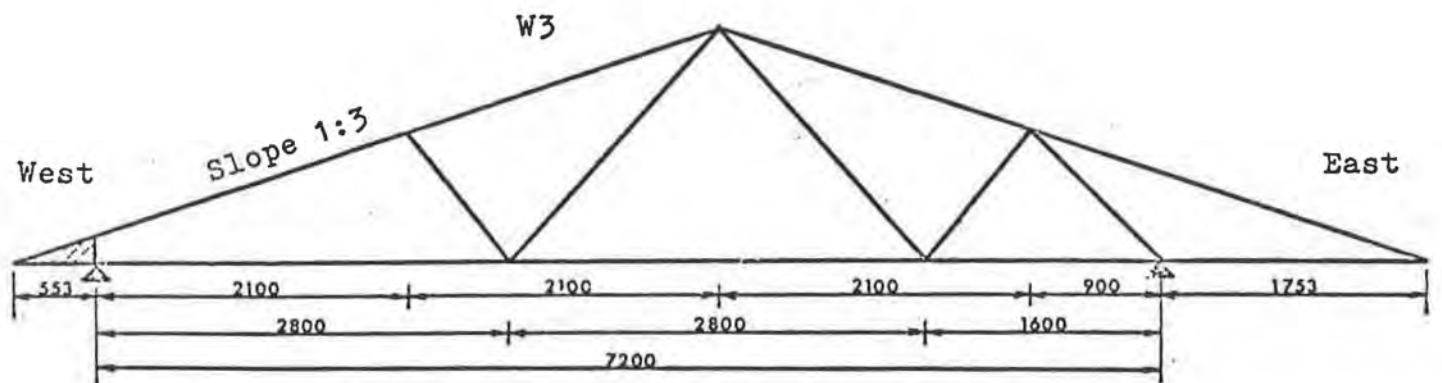
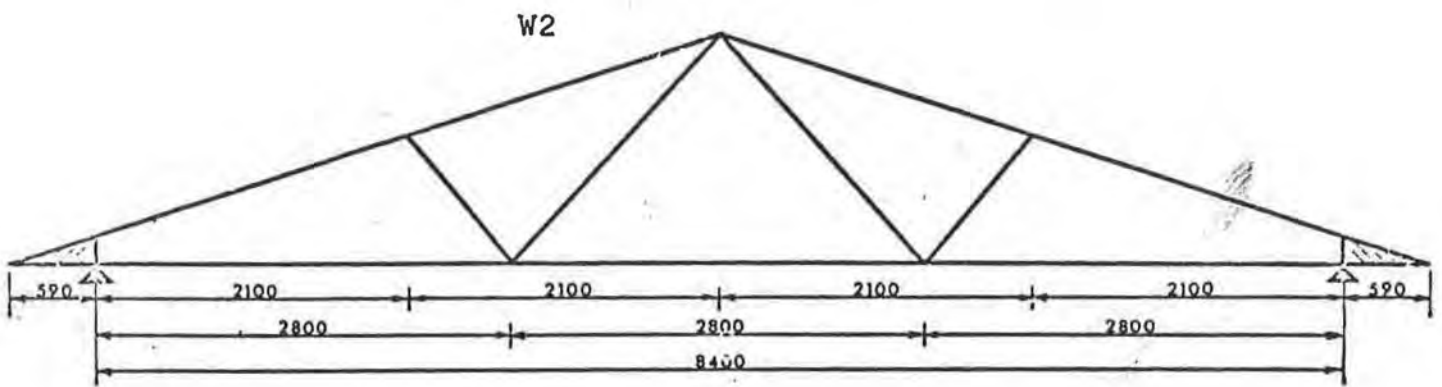
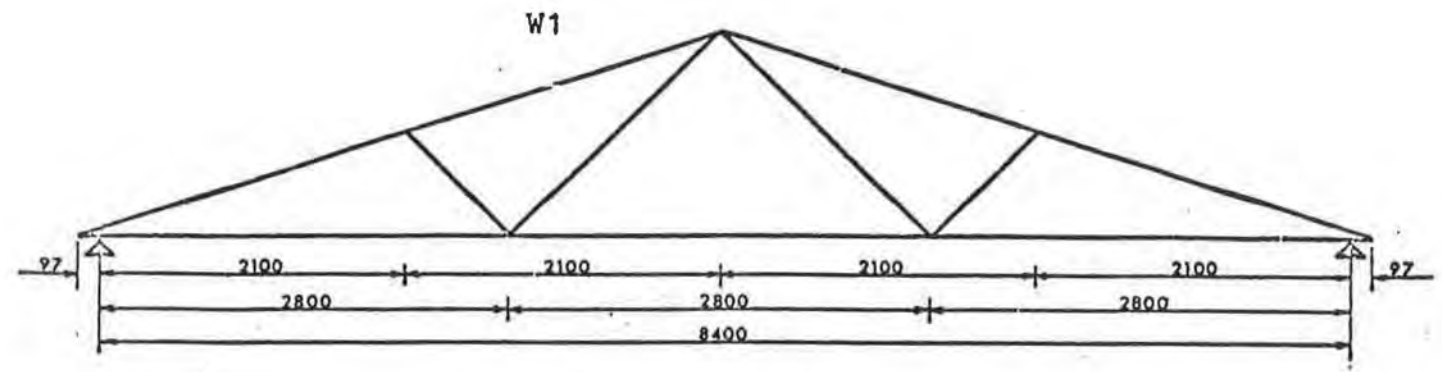
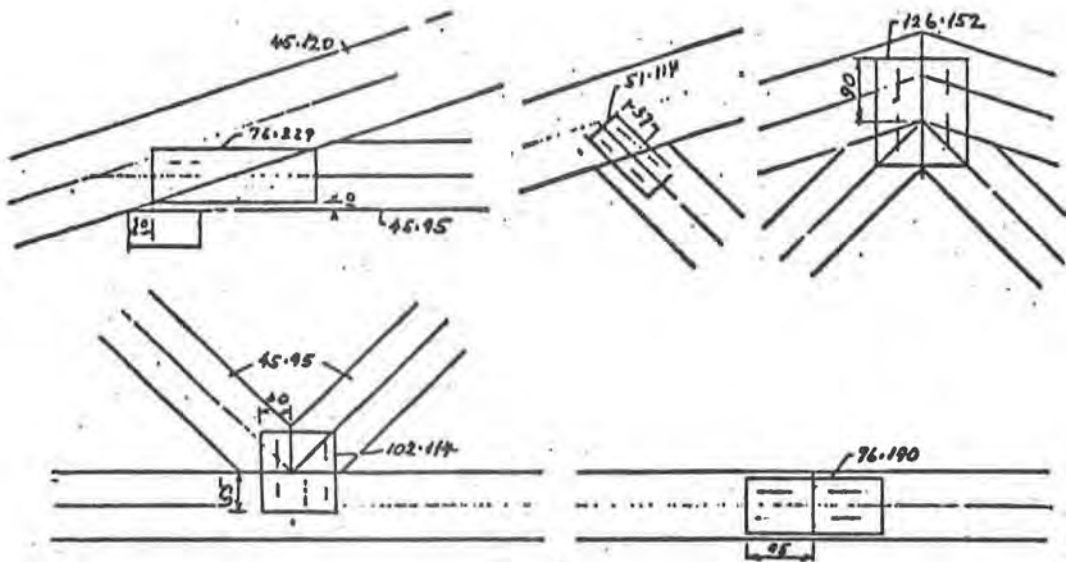
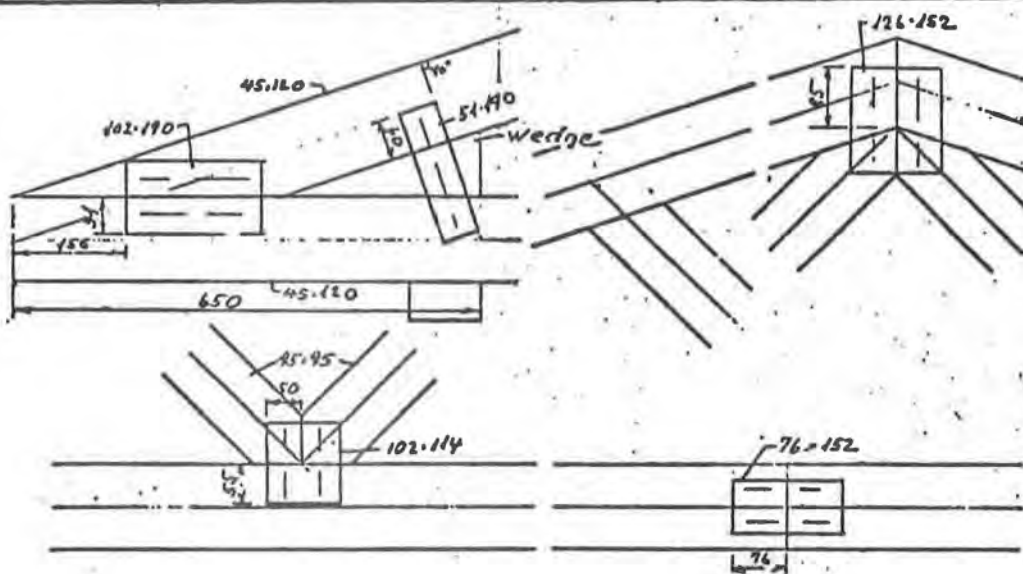

Fig.1  
W-type trussed rafters



LW1



LW2

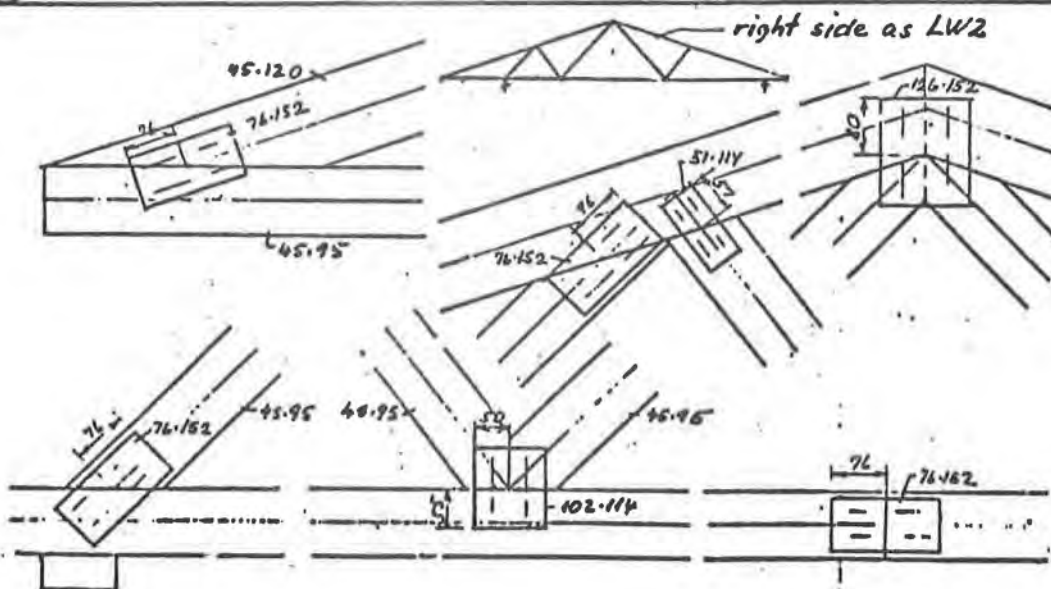

LW3

Fig.2a  
Joint details for  
Hydro-Nail plates



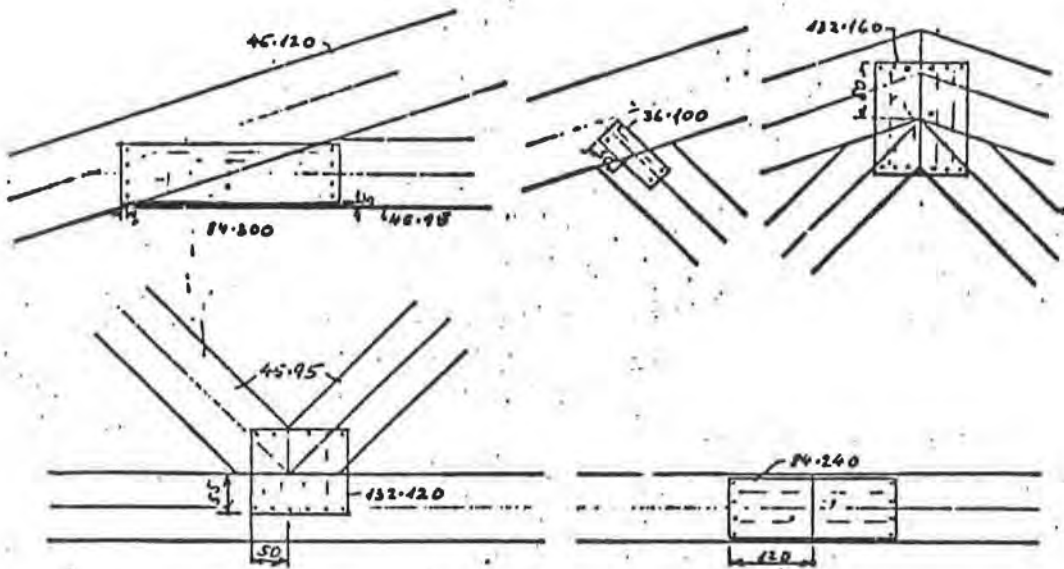

LW1-Tc

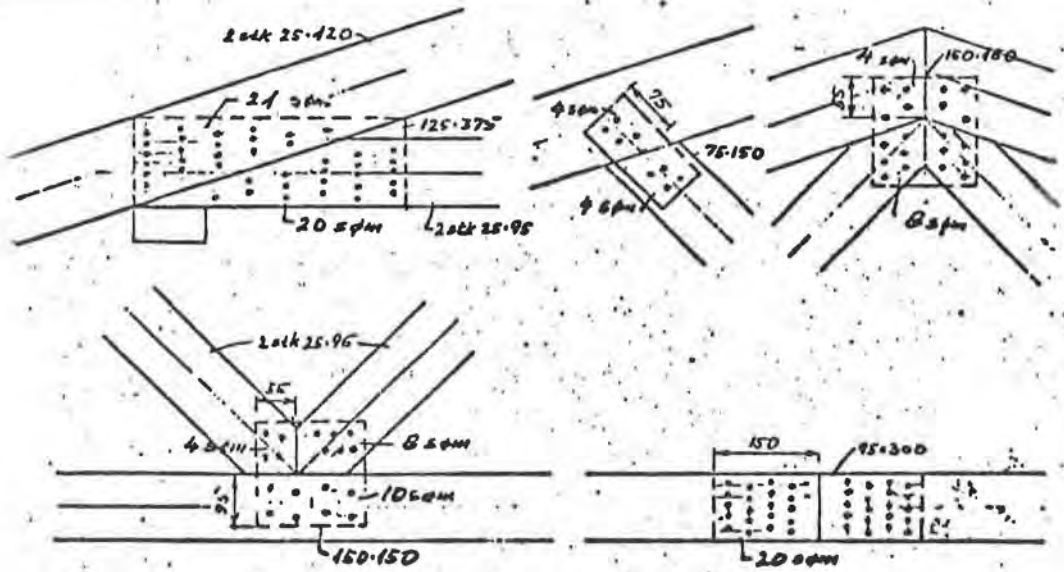

LW1-Br

1.25mm galv. steel plate  
 Nails 25/50

Fig.2d  
 Joint details for  
 TCT Roll-Lock  
 plates and  
 Metal plate between  
 two boards nailed  
 from one side





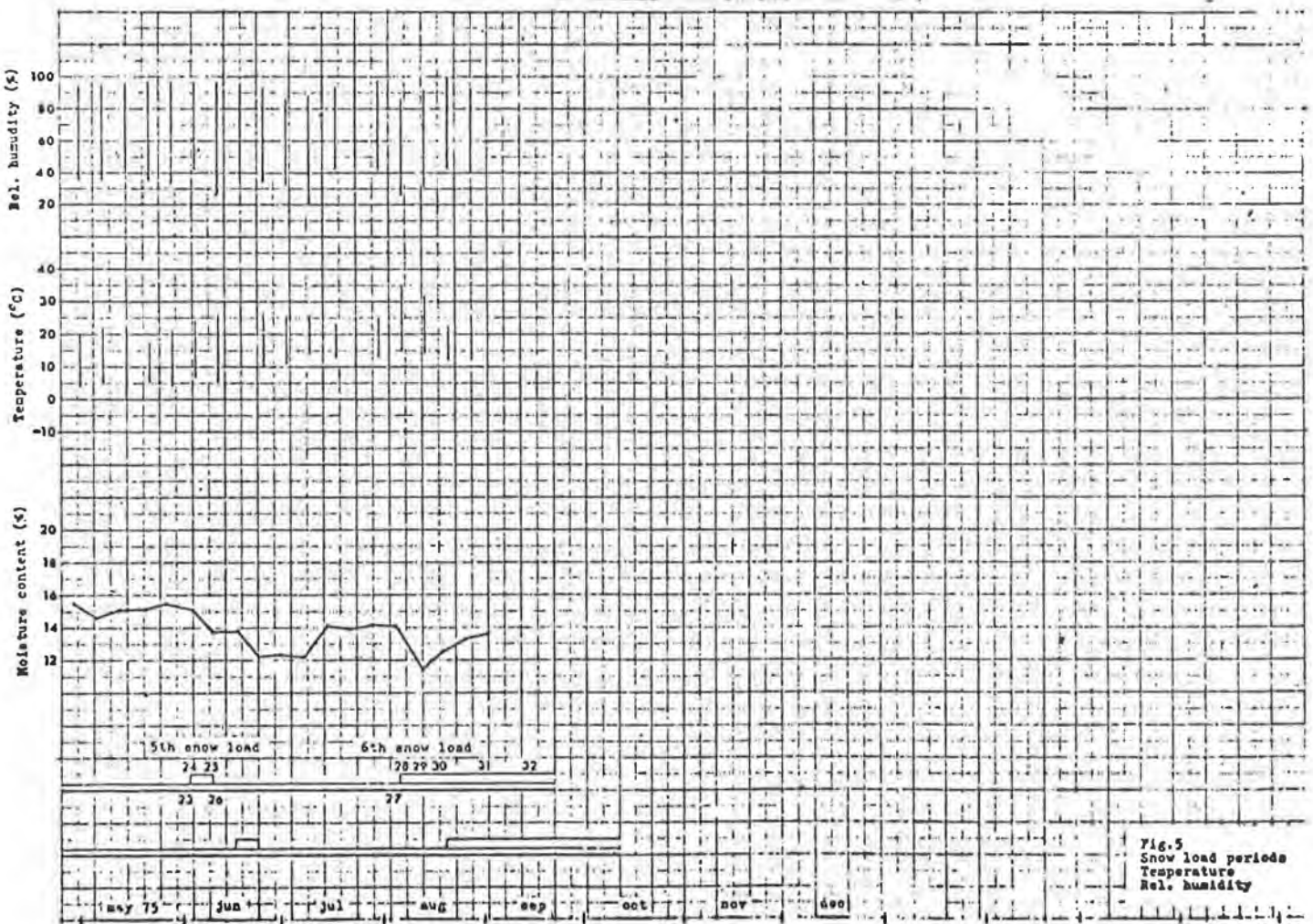
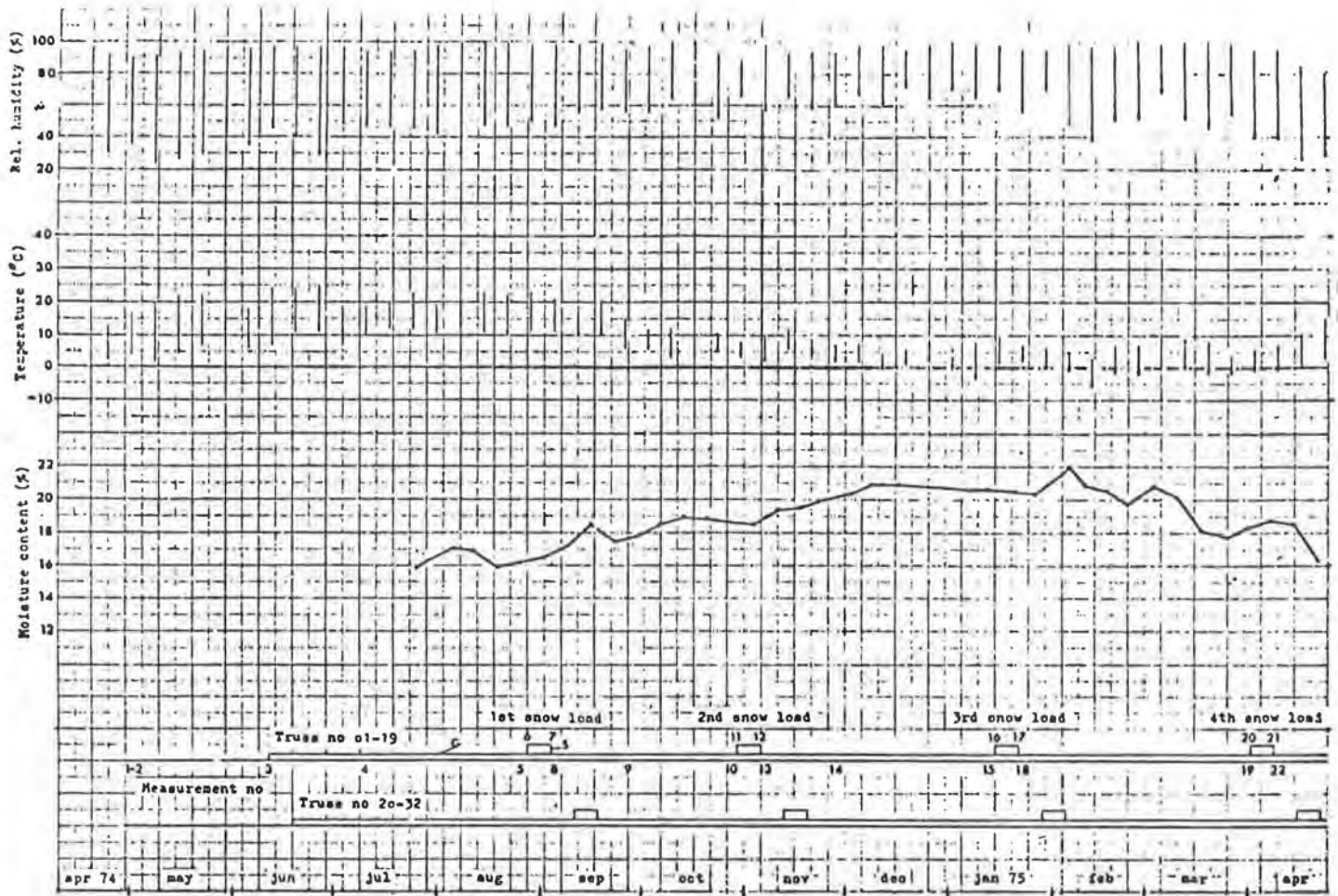

Fig. 5  
 Snow load periods  
 Temperature  
 Rel. humidity

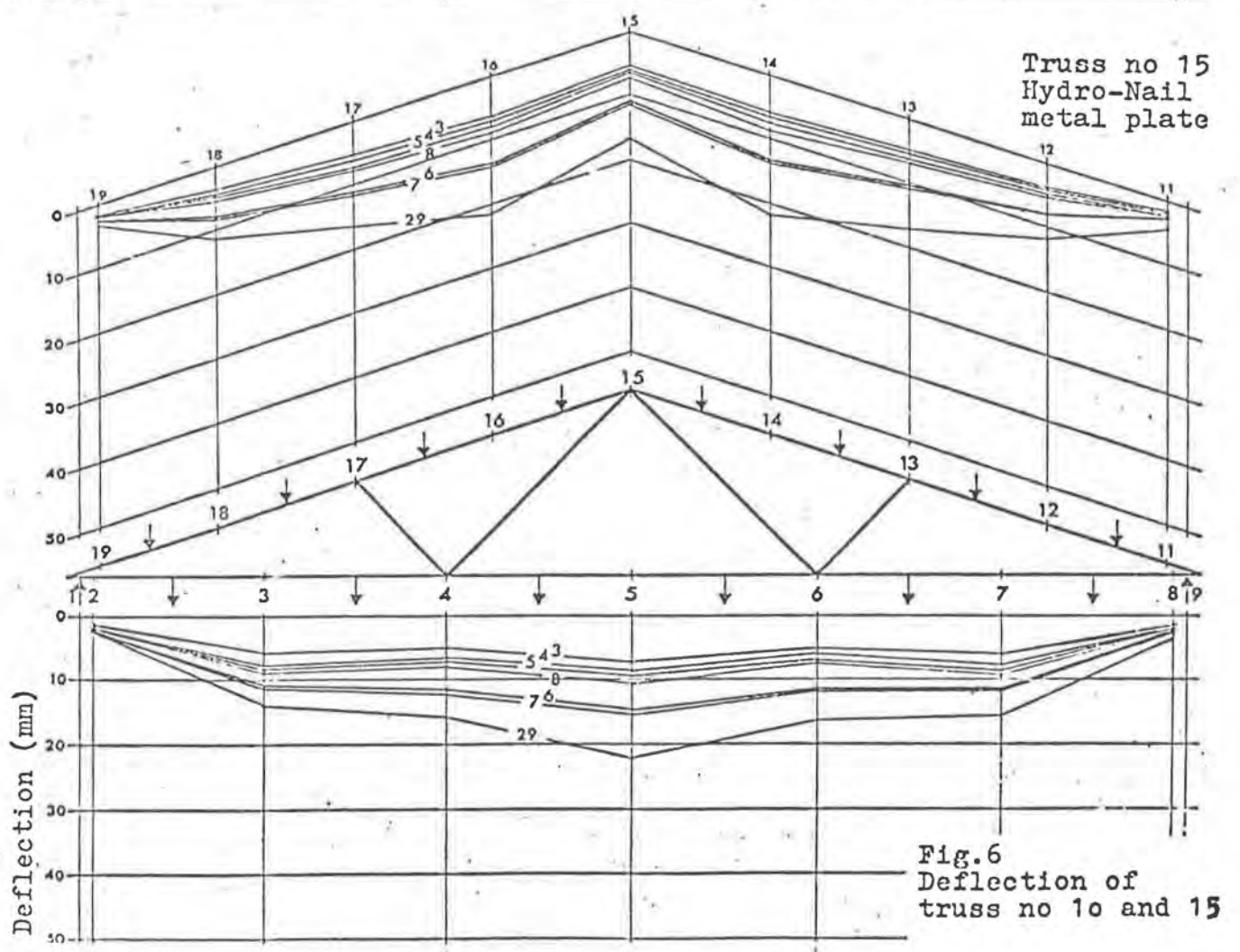
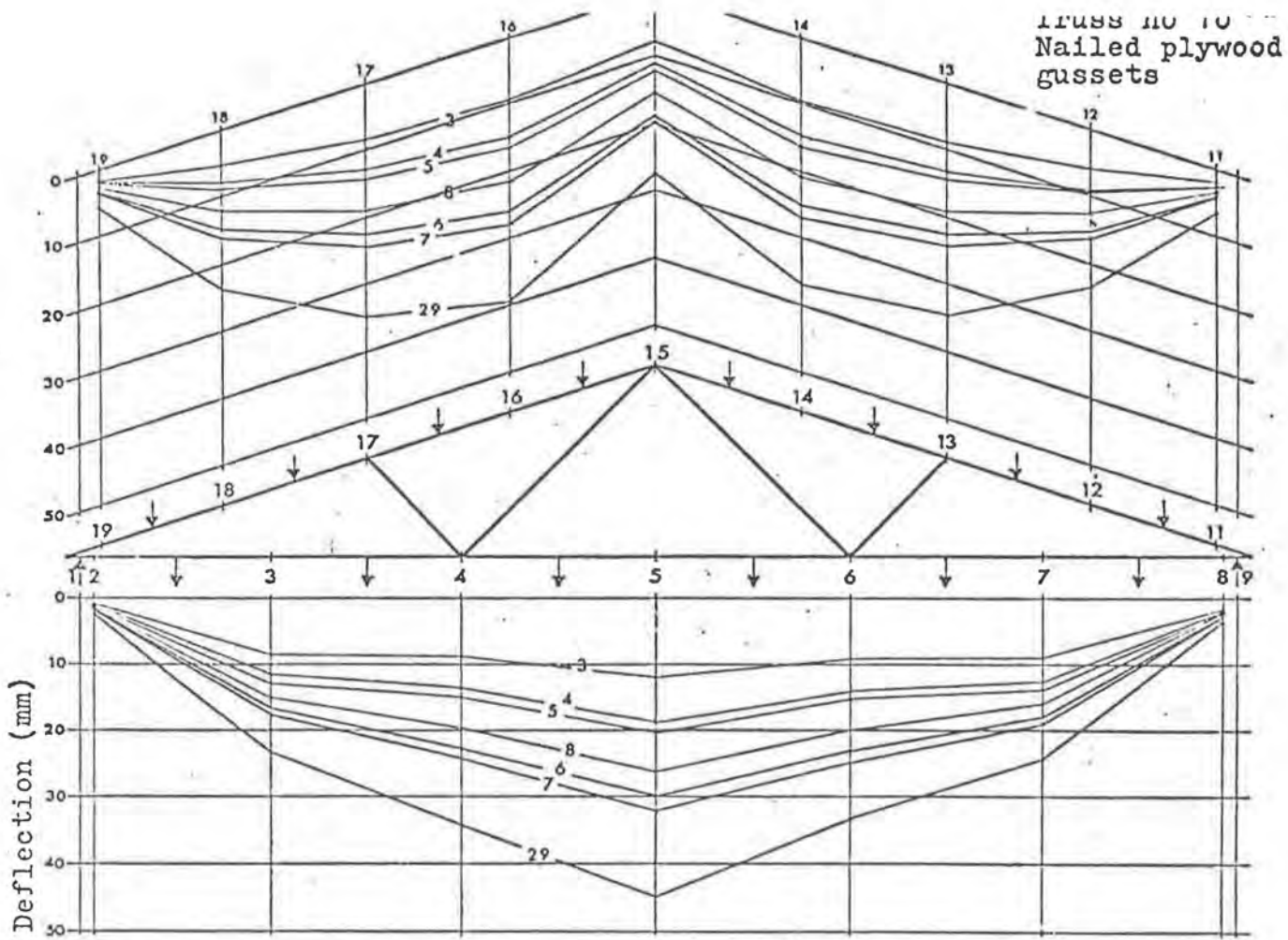

Fig.6  
Deflection of  
truss no 10 and 15

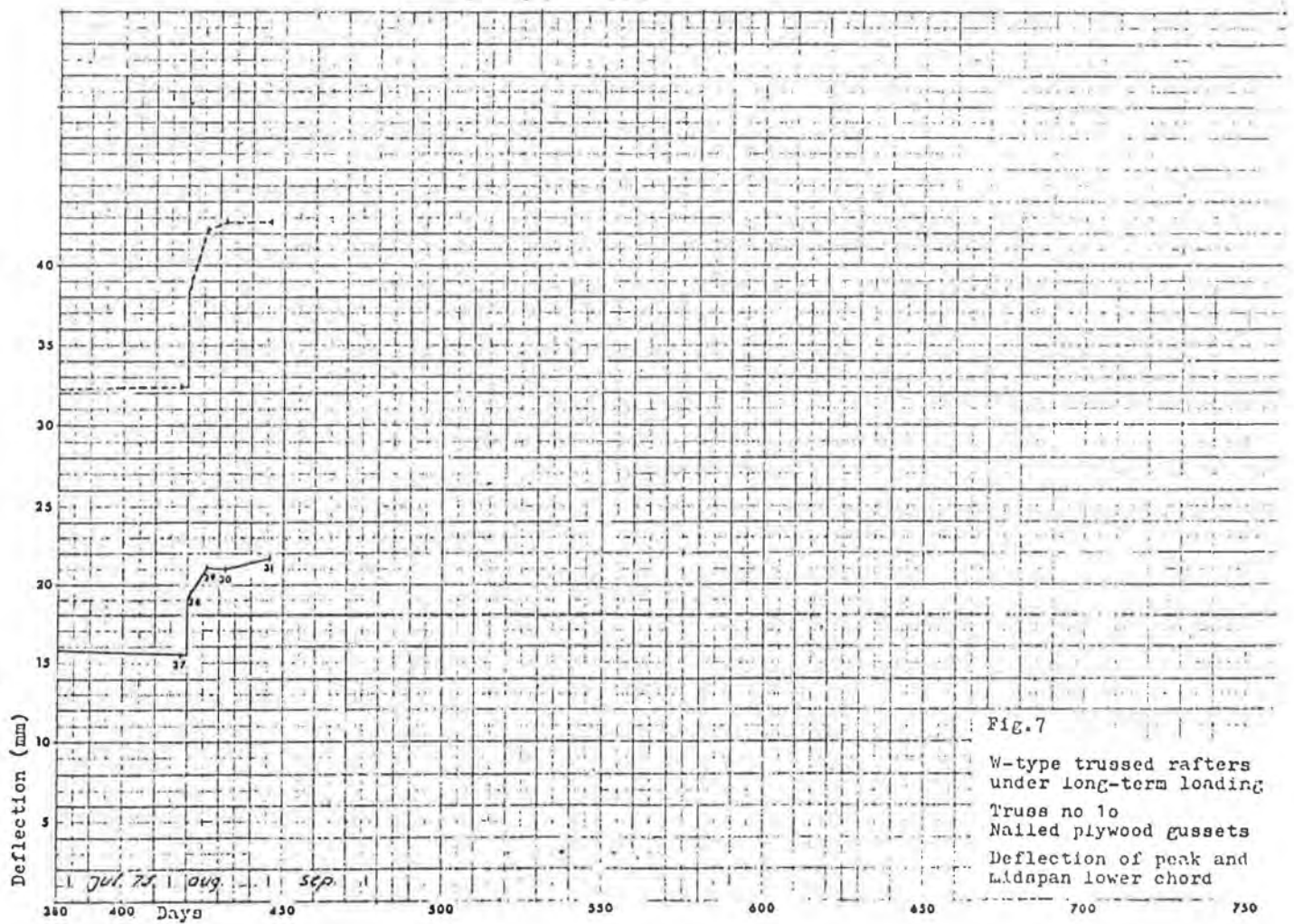
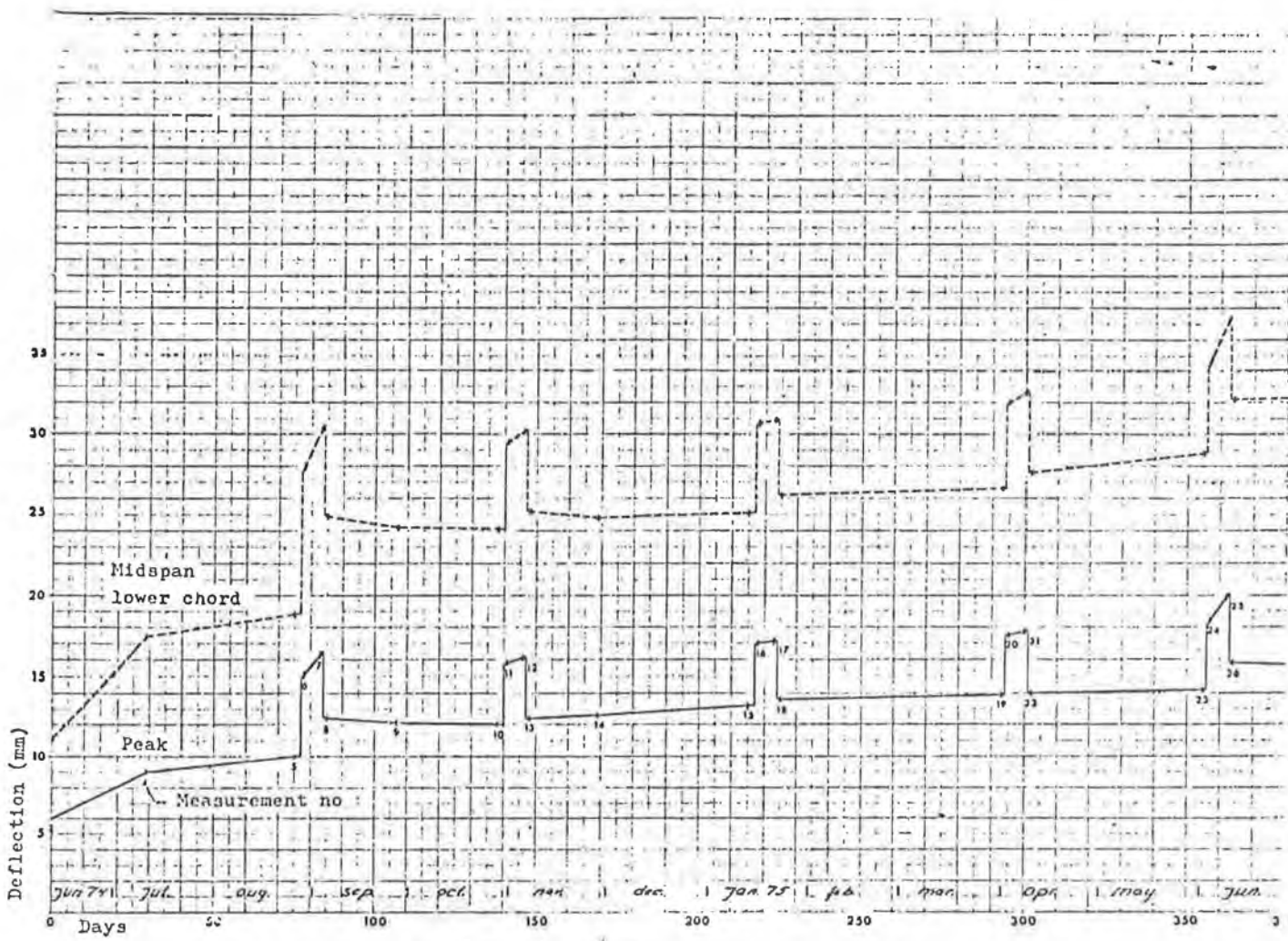

Fig. 7  
 W-type trussed rafters  
 under long-term loading  
 Truss no 1c  
 Nailed plywood gussets  
 Deflection of peak and  
 Midspan lower chord

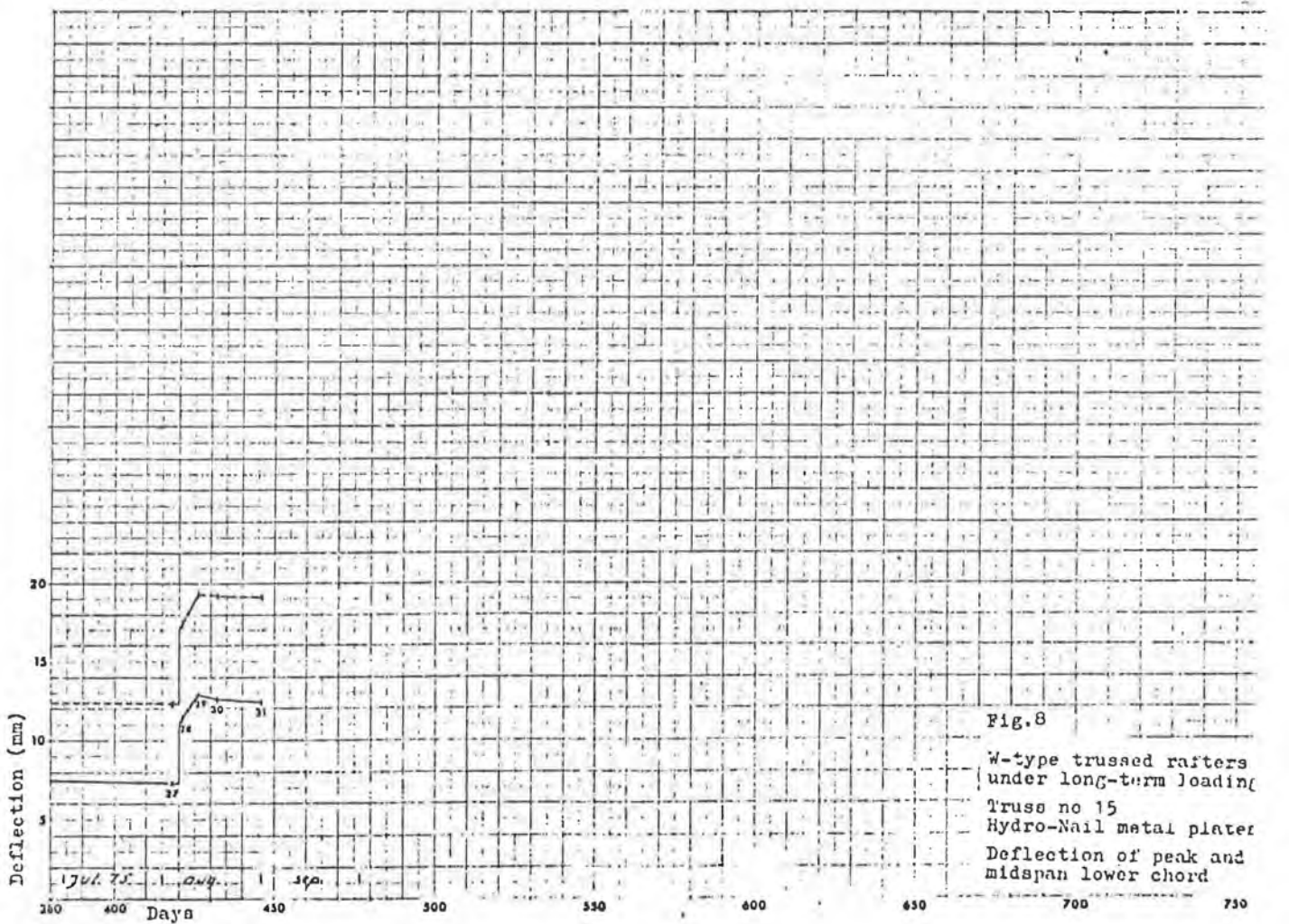
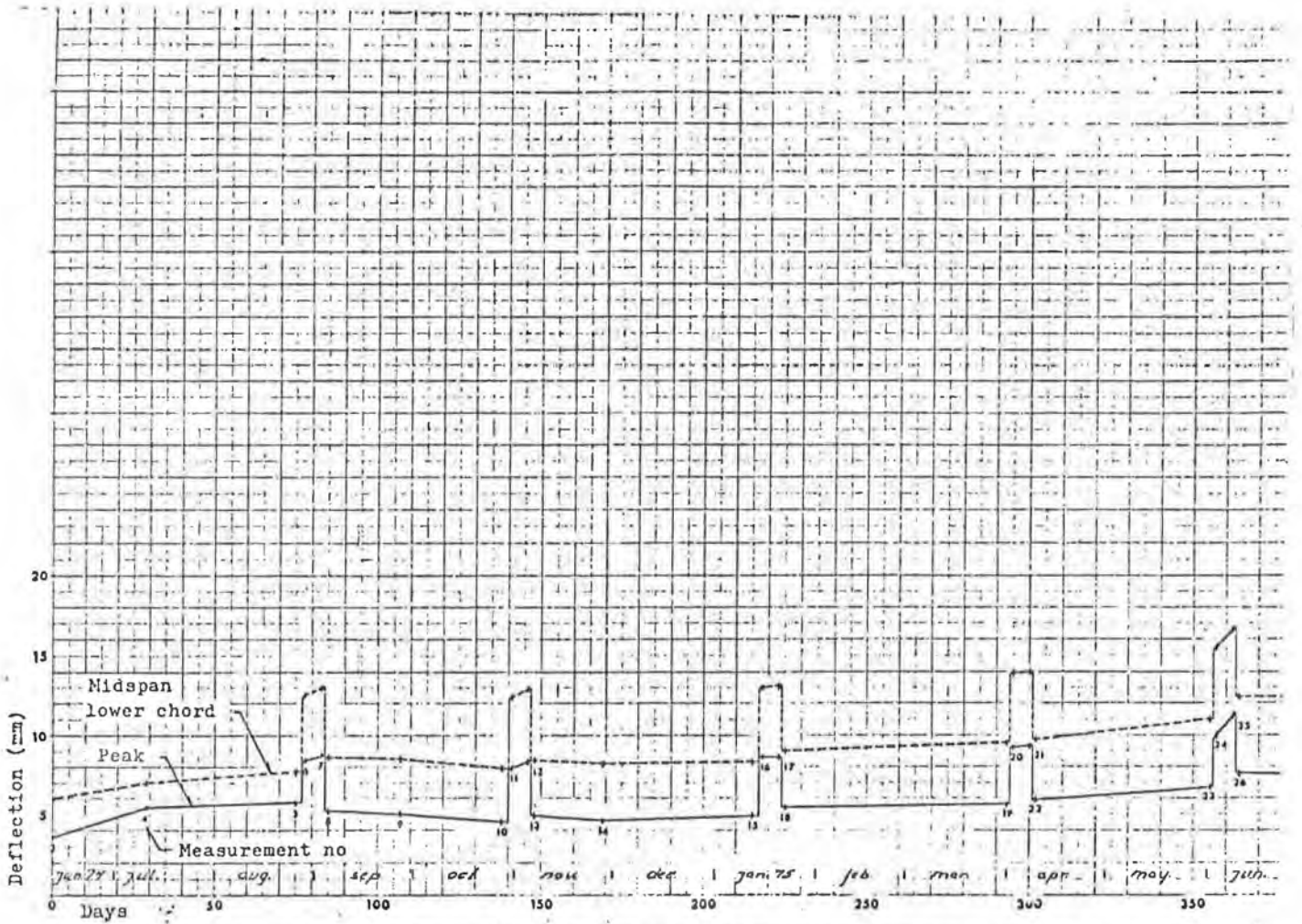

Fig. 8

W-type trussed rafters  
 under long-term loading  
 Truss no 15  
 Hydro-Nail metal plater  
 Deflection of peak and  
 midspan lower chord

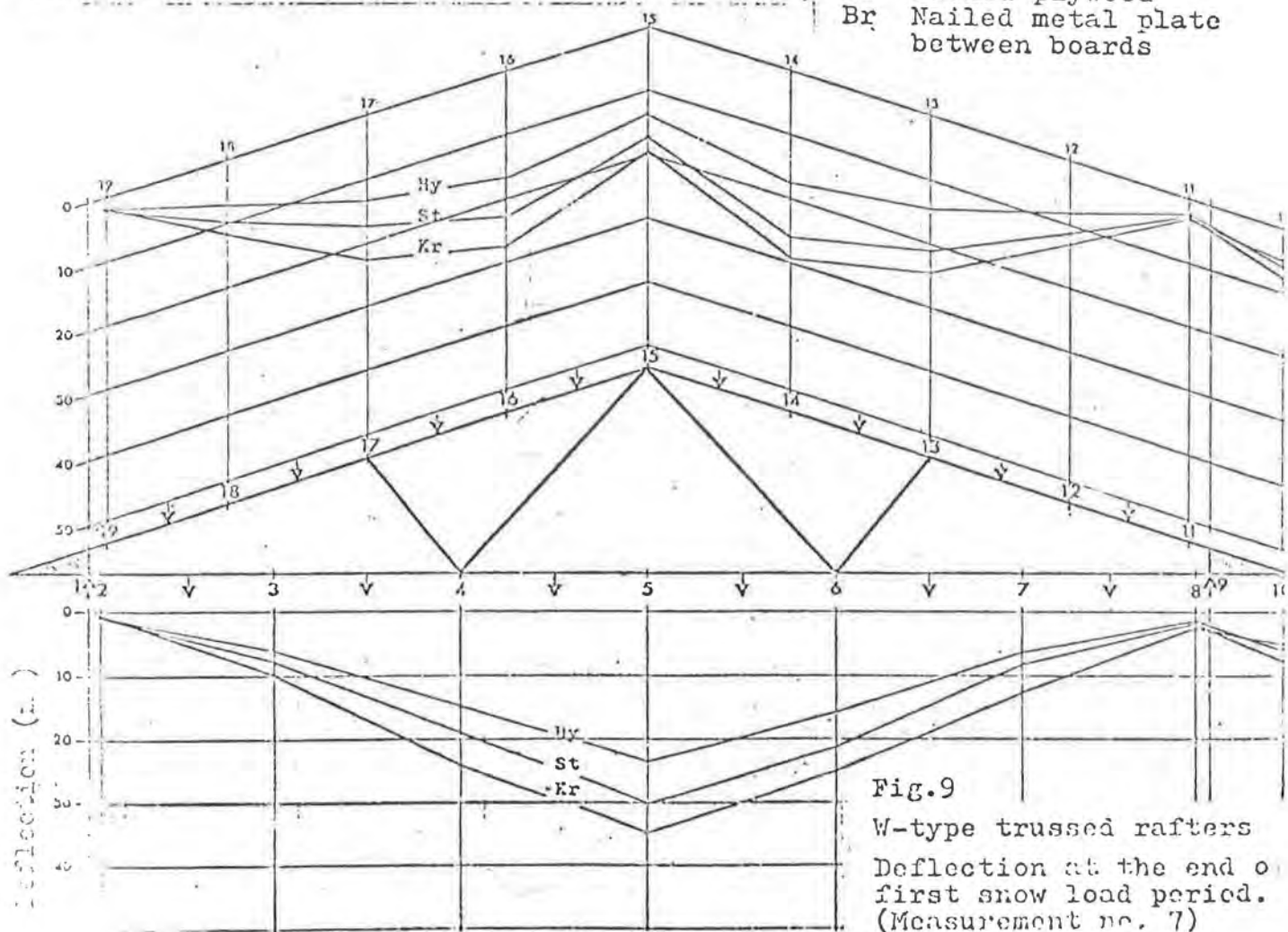
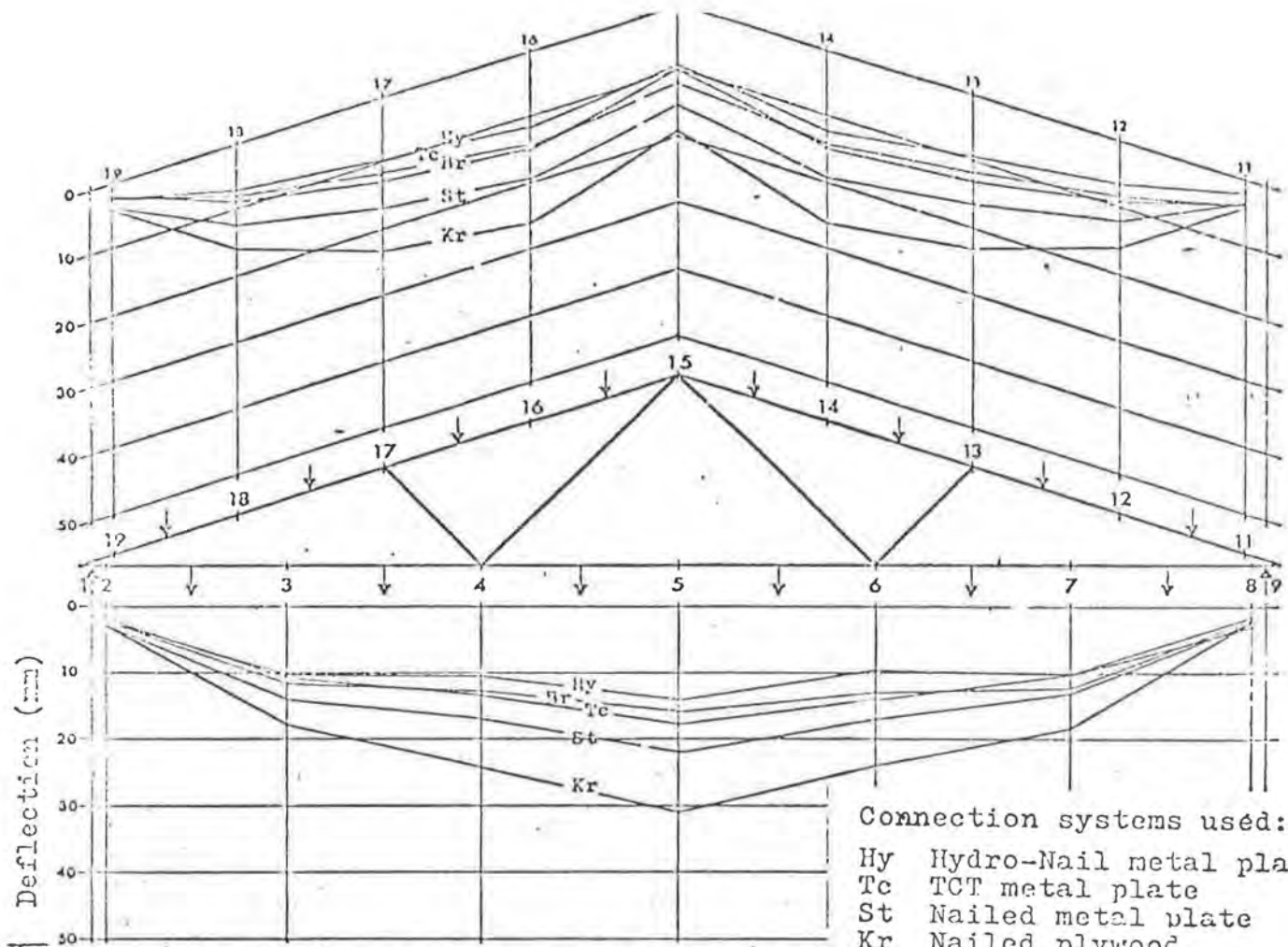

Table 1 Dimensions and modulus of elasticity of chord members.

Truss No.	Truss Type	Trusses rafter connection system	Dimensions (mm)		Modulus of elasticity ( $kN/mm^2$ )				
			Upper chords	Lower chords	Upper chords		Lower chords		
					West side	East side	West side	East side	
01	W1	e) Metal plates between 2 boards, nailed from 1 side	Double 25.125	Double 25.100					
02			-	-					
03		b) TCT Roll-Lock plates	45.120	45.95	18.4	17.6	11.1		
04			-	-	12.8	17.6	11.0		
05			c) Nailed metal plates	-	-		13.9	11.0	9.4
06				-	-	13.2	13.4	12.1	13.1
07		-		-	12.7	15.1	11.0	11.6	
08		-		-	12.4	16.7	10.9	13.2	
09		d) Nailed plywood gussets	-	-	14.1	14.3	12.5	12.1	
10			-	-	14.5	17.3	11.2	14.3	
11			-	-	9.0	10.0	10.9	10.9	
12			-	-	14.0	14.4	11.3	13.5	
13			a) Hydro Nail plates	-	-	16.5	12.1	11.2	
14				-	-	15.7	6.8	10.2	14.6
15		-		-	12.4	13.0		14.0	
16		-		-	13.6	14.2			
17		-		-	14.4	13.0		11.4	
18		-		45.145	-	-		14.5	15.3
19		-		-	-	-		10.2	11.3
20	W2	d) Nailed plywood gussets	45.120	45.120	11.0	14.4	18.9	11.0	
21		a) Hydro Nail	-	-	14.7	12.4	12.6	13.8	
22		-	-	-	16.0	15.6		12.5	
23		c) Nailed metal plates	-	-		13.4	16.3	13.4	
24			-	-	-	-	17.0	12.2	
25		d) Nailed plywood	-	-	14.7	12.9	10.0	8.1	
26			-	-	15.8	15.2	15.1	14.9	
27	W3	a) Hydro Nail	-	45.95	13.6	12.3	9.2	10.6	
28		-	-	-	14.2	14.8	14.3	12.5	
29		c) Nailed metal plates	-	-	13.2	13.2	10.4	12.9	
30			-	-	12.2	17.6	11.0	8.6	
31		d) Nailed plywood	-	-	12.2	15.2	8.1	8.2	
32			-	-	12.7	11.1	12.0	9.5	

Table 2

DEFLECTION OF W-TRUSSED RAFTERS UNDER LONG-TERM LOADING

LOAD G, MEASUREMENT NO 3, WEEK NO 18 AND 21 1974

TRUSS	SUPP	LOWER CHORD							SUPP	UPPER CHORD										
		1	2	3	4	5	6	7		8	9	10	11	12	13	14	15	16	17	18
15	1	0.0	1.0	4.8	4.9	6.9	5.0	4.9	1.6	-0.0	*****	1.8	3.8	5.0	5.5	3.6	5.2	4.3	3.2	1.0
	2	0.0	0.7	5.8	5.6	8.6	6.2	5.3	1.6	-0.0	*****	2.0	4.4	5.7	6.2	5.1	6.3	5.2	3.6	0.8
17	3	0.0	0.9	6.1	4.8	6.7	4.8	5.8	1.5	0.0	*****	1.7	3.4	4.3	5.1	4.6	5.1	4.7	3.1	1.1
	4	0.0	0.4	6.3	4.7	6.2	4.9	6.9	1.5	0.0	*****	1.5	3.5	4.6	5.2	4.4	5.1	4.2	2.9	0.6
19	5	0.0	1.0	7.4	6.7	8.5	6.3	6.4	1.0	0.0	*****	1.5	4.5	6.3	7.1	6.3	7.2	6.4	4.6	1.4
	6	0.0	1.1	7.7	7.6	10.3	7.5	7.4	1.3	0.0	*****	1.8	5.2	7.4	8.1	7.2	8.0	7.1	5.1	1.5
21	7	0.0	1.6	11.3	12.3	15.6	12.3	11.0	1.7	0.0	*****	2.2	7.9	11.6	13.8	10.3	14.4	12.1	8.4	2.1
	8	0.0	1.4	10.1	11.2	15.3	11.2	9.2	1.8	0.0	*****	2.4	7.9	11.5	13.3	9.3	14.1	11.1	7.4	1.8
23	9	0.0	1.4	9.0	9.3	12.8	9.1	8.9	1.5	0.0	*****	1.9	6.0	9.2	10.3	7.6	10.3	9.0	6.1	1.7
	10	0.0	0.7	8.5	8.9	12.1	9.0	8.9	1.3	0.0	*****	1.7	5.6	8.6	9.6	7.5	9.7	8.2	5.2	1.4
25	11	0.0	1.9	13.8	16.5	21.1	16.3	12.9	2.8	-0.0	*****	3.8	11.0	16.2	18.8	13.0	18.5	16.2	11.4	2.7
	12	0.0	0.9	10.2	13.9	18.4	14.1	11.5	2.0	-0.0	*****	2.8	9.2	13.8	15.7	11.1	15.6	13.9	9.3	2.0
27	13	0.0	0.2	0.7	1.1	1.7	1.2	0.6	0.3	0.0	*****	0.5	0.9	1.3	1.7	1.4	1.5	1.1	0.7	0.2
	14	0.0	0.7	4.9	3.7	5.4	4.0	5.1	0.4	0.0	*****	0.7	2.4	3.8	5.0	4.0	4.4	3.8	2.8	0.9
29	15	0.0	1.2	5.8	5.0	7.2	5.1	6.2	1.3	-0.0	*****	1.5	3.6	4.9	5.9	5.1	6.2	5.1	3.4	1.5
	16	0.0	1.2	7.3	7.6	10.0	7.5	7.9	1.1	0.0	*****	1.4	5.5	7.4	9.0	7.2	9.7	7.1	4.9	1.4
31	17	0.0	1.6	9.3	8.4	10.9	8.5	9.5	2.1	0.0	*****	2.3	6.2	8.0	9.8	8.0	10.3	8.1	5.6	1.8
	18	0.0	2.2	7.1	7.1	10.2	7.3	7.9	1.3	0.0	*****	1.7	4.9	7.3	8.4	7.3	7.8	6.8	5.0	2.2
33	19	0.0	1.6	7.5	6.7	8.9	6.9	7.4	1.4	0.0	*****	1.6	4.6	6.9	8.0	6.5	7.5	6.4	4.7	1.8
	20	0.0	0.1	0.5	1.0	1.9	1.4	0.4	0.1	0.0	0.6	0.1	1.2	1.3	2.0	1.5	1.7	1.4	0.6	0.2
35	21	0.0	1.1	3.8	5.6	8.4	5.7	3.7	1.4	-0.0	2.6	1.9	3.7	5.8	6.4	5.5	6.5	5.4	3.2	1.4
	22	0.0	1.5	3.6	6.4	9.9	6.5	3.7	1.7	-0.0	3.1	1.9	4.0	6.6	7.6	6.4	7.3	6.4	3.8	2.1
37	23	0.0	1.1	4.5	9.0	13.5	9.5	5.0	1.2	-0.0	2.7	2.6	5.6	9.2	10.4	8.6	10.0	8.6	4.8	1.7
	24	0.0	1.5	4.4	8.4	13.1	9.3	5.0	1.9	-0.0	4.2	2.8	5.9	10.0	11.7	8.2	10.0	8.4	5.1	2.5
39	25	0.0	0.7	5.4	9.2	13.4	10.1	6.5	2.1	-0.0	2.9	2.1	5.3	9.9	11.5	8.2	10.2	8.6	4.4	1.0
	26	0.0	0.9	4.5	8.2	12.3	8.6	5.5	1.8	-0.0	2.3	2.0	5.1	8.6	9.7	7.0	9.7	8.2	4.1	1.3
41	27	0.0	0.8	4.2	3.6	5.2	1.9	0.9	*****	0.0	1.6	*****	1.8	1.3	2.1	2.1	3.4	3.2	1.8	0.7
	28	0.0	0.9	3.2	3.6	6.0	1.9	0.6	*****	0.0	0.9	*****	1.7	1.1	2.3	2.4	3.7	3.4	1.9	0.8
43	29	0.0	0.7	4.4	5.2	8.6	3.3	0.5	*****	0.0	0.4	*****	2.3	2.0	3.8	3.5	5.4	5.0	3.2	1.1
	30	0.0	0.7	4.7	5.9	9.1	3.7	0.7	*****	0.0	-0.4	*****	1.5	2.5	4.1	4.2	6.6	6.0	3.6	1.3
45	31	0.0	0.8	5.5	6.2	9.6	3.9	0.3	*****	0.0	0.2	*****	2.1	2.4	4.0	4.4	6.7	6.1	3.5	0.9
	32	0.0	1.3	5.7	6.0	9.3	3.6	0.2	*****	0.0	0.5	*****	2.3	2.2	3.9	3.8	6.1	5.6	3.7	1.3

49  
 48  
 47  
 46  
 45  
 44  
 43  
 42  
 41  
 40  
 39  
 38  
 37  
 36  
 35  
 34  
 33  
 32  
 31  
 30  
 29  
 28  
 27  
 26  
 25  
 24  
 23  
 22  
 21  
 20  
 19  
 18  
 17  
 16  
 15  
 14  
 13  
 12  
 11  
 10  
 9  
 8  
 7  
 6  
 5  
 4  
 3  
 2  
 1

3

Table 4

5

## DEFLECTION OF W-TRUSSED RAFTERS UNDER LONG-TERM LOADING

7

9

LOAD G+S, MEASUREMENT NO 29, WEEK NO 33 AND 35 1975

11

TRUSS	SUPP	LOWER CHORD								UPPER CHORD										
		1	2	3	4	5	6	7	8	9	10	11	12	13	14	15	16	17	18	19
13	1	0.0	2.5	14.3	18.4	23.4	17.9	14.9	5.0	-0.0	*****	6.4	15.7	20.5	22.8	14.7	23.1	19.4	13.8	4.4
15	2	0.0	3.1	15.7	18.6	26.6	19.1	14.0	3.8	-0.0	*****	5.6	15.0	20.2	24.0	16.4	24.4	21.8	15.9	4.9
17	3	0.0	2.2	14.1	15.5	21.1	16.2	15.2	3.7	0.0	*****	4.8	12.7	16.6	20.3	15.8	20.0	16.8	11.4	3.8
19	4	0.0	2.2	16.0	17.1	21.1	16.4	16.3	2.8	0.0	*****	4.2	12.1	17.2	20.6	16.5	22.0	16.9	11.3	3.5
21	5	0.0	1.9	18.1	23.1	28.9	21.0	15.8	2.1	0.0	*****	4.5	16.2	22.3	26.9	20.8	29.7	23.9	16.9	3.8
23	6	0.0	2.7	19.3	23.8	31.0	24.4	18.5	3.1	0.0	*****	5.5	17.9	25.1	29.8	22.4	29.4	24.7	17.7	4.8
25	7	0.0	3.6	25.4	33.1	41.1	31.4	23.4	3.7	0.0	*****	6.5	22.9	31.8	37.1	27.7	41.5	34.8	24.5	5.4
27	8	0.0	2.6	22.9	30.8	39.4	29.5	20.4	3.5	0.0	*****	6.2	22.5	31.3	36.2	26.3	40.3	32.2	21.7	4.8
29	9	0.0	2.8	23.2	31.7	40.7	31.6	23.5	2.9	0.0	*****	6.1	22.0	33.0	35.9	25.6	35.8	32.0	22.5	5.6
31	10	0.0	2.2	23.4	34.2	45.0	33.3	24.4	3.4	0.0	*****	6.7	23.5	34.5	37.1	27.4	39.6	34.9	23.7	5.8
33	11	0.0	3.6	31.2	43.4	56.0	43.5	30.4	5.2	-0.0	*****	8.7	30.1	44.3	49.4	33.6	48.8	44.1	30.2	6.8
35	12	0.0	1.9	23.8	36.3	49.3	38.6	27.9	3.2	-0.0	*****	6.7	26.3	40.2	43.5	28.9	39.1	36.5	24.2	5.4
37	13	0.0	0.3	0.6	1.8	3.1	2.5	1.4	0.0	-0.0	*****	1.4	2.3	3.5	4.4	3.2	3.4	2.4	1.3	0.6
39	14	0.0	1.9	11.9	12.3	17.9	14.0	12.6	0.9	-0.0	*****	2.1	8.9	14.3	20.2	13.3	16.2	13.5	10.1	2.7
41	15	0.0	2.5	14.0	15.8	22.2	16.4	15.6	3.5	-0.0	*****	4.6	11.8	17.1	21.8	16.7	21.3	16.5	11.1	3.2
43	16	0.0	2.5	16.6	20.6	27.5	20.7	18.7	3.4	0.0	*****	4.9	16.2	21.0	26.2	20.3	30.8	20.9	13.8	3.9
45	17	0.0	2.9	19.3	21.3	28.3	21.4	19.8	3.8	0.0	*****	5.4	16.4	21.9	28.4	21.2	30.4	22.2	14.5	4.2
47	18	0.0	4.9	17.0	19.2	26.9	19.8	18.2	3.1	0.0	*****	5.4	15.1	21.2	25.8	20.1	22.9	19.6	15.1	6.2
49	19	0.0	3.8	16.7	18.3	25.0	18.6	16.3	2.9	-0.0	*****	4.4	13.6	19.6	24.7	18.7	23.2	19.5	14.2	5.6
51	20	0.0	0.4	1.2	3.0	5.2	3.6	1.1	0.0	-0.0	1.5	0.4	2.1	4.5	5.1	4.2	5.1	4.2	1.9	0.7
53	21	0.0	1.8	8.9	19.0	29.0	19.1	8.1	2.1	0.0	7.8	4.9	11.9	19.7	23.8	18.6	23.5	19.0	11.3	4.1
55	22	0.0	2.5	7.7	20.1	31.8	20.7	8.5	2.2	0.0	9.2	5.0	13.0	21.5	25.6	19.9	24.9	20.7	12.8	5.6
57	23	0.0	1.6	11.9	28.6	43.5	29.9	13.0	3.0	-0.0	9.4	8.1	18.7	30.3	35.8	26.6	35.6	28.9	16.3	4.9
59	24	0.0	2.2	10.9	26.3	40.7	30.2	12.5	3.3	-0.0	13.2	7.1	19.4	33.0	38.8	26.1	32.1	26.6	16.3	6.1
61	25	0.0	1.8	15.9	33.7	49.4	35.4	17.9	3.7	0.0	8.1	5.9	19.6	35.6	42.3	28.7	38.1	32.5	17.9	4.2
63	26	0.0	1.9	13.5	29.7	42.9	30.2	15.4	3.0	0.0	5.0	5.5	18.3	31.2	34.6	24.6	35.7	30.7	17.2	4.7
65	27	0.0	0.9	8.4	13.8	19.2	8.4	2.4	*****	0.0	1.1	*****	9.7	7.0	11.1	10.6	17.7	15.0	9.2	3.0
67	28	0.0	0.5	5.7	11.9	16.8	6.6	0.9	*****	0.0	0.0	*****	8.6	5.2	10.1	9.0	15.3	12.9	7.3	2.1
69	29	0.0	1.6	10.5	19.7	26.6	12.0	1.6	*****	0.0	2.7	*****	10.4	8.8	16.1	13.7	24.8	21.2	13.2	4.9
71	30	0.0	1.6	10.5	20.1	27.0	11.9	1.2	*****	0.0	2.0	*****	9.4	8.8	14.9	14.4	25.2	22.5	14.1	5.4
73	31	0.0	2.0	15.2	25.0	32.6	14.8	1.6	*****	0.0	5.9	*****	12.1	11.4	17.6	16.6	30.6	26.6	15.7	4.4
75	32	0.0	2.8	14.6	23.3	31.6	13.4	1.1	*****	0.0	6.2	*****	12.4	10.2	17.0	14.8	26.4	24.2	15.3	4.6

1) Load G only

INTERNATIONAL COUNCIL FOR BUILDING RESEARCH STUDIES AND DOCUMENTATION

WORKING COMMISSION W18 - TIMBER STRUCTURES

CLIMATE GRADING (2)

by

B NORÉN  
Swedish Forest Products Research Laboratory  
Stockholm  
Sweden

Aalborg, Denmark - June 1976

## CLIMATE GRADING (2)

B Norén - Svenska Träforskningsinstitutet, Stockholm

### Background

The discussion of the paper "Climate Grading for the Code of Practice" (CIB-W18/5-11-1) resulted in the author being asked to draft an outline on the matter for the CIB-code for timber structures. This outline is presented here. It is based on the record from the Karlsruhe-meeting and written independently of the § 2.2 "Climate classes" in the first draft of the "CIB Timber Code" (paper 6-100-2). Thus there are some small deviations in RH-values and in the grouping of structures.

In neither of the proposals are testing conditions dealt with. In ISO the Committee TC 125 is responsible for the atmosphere of testing and conditioning. The opinion within the Committee seems to be that 23/50 should replace the previous 20/65 as "normal testing climate". Furthermore, it has been proposed within the Nordic standard organization INSTA that other levels should be 23/30 and 23/90, principally for testing dimensional stability at changes in relative humidity. These proposals deviate from the climates to which design stresses are linked in most timber structural codes. The 23/30 can be accepted as a limit for cycling in climate class 1 but is too dry to represent normal European interior climate and 23/90 is too humid for climate class 2.

### Climate classes (CIB-code)

1. Characteristic values of strength and stiffness refer to certain standard climate classes, formally defined by relative air humidity (RH, %) and temperature 23°C:

Climate 1H	RH 40	Dry interior
Climate 1	RH 60	Normal interior
Climate 2	RH 80	Humid interior or protected exterior
Climate 3	Soaked	Non-protected exterior and sub-water

2. Characteristic long-term-values (or corresponding conversion factors) refer to a normal variation (several times per month) of relative humidity:

60 to 40 in climate 1  
 80 to 60 in climate 2  
 80 to 40 in climate 2/1

3. Structures are referred to the standard climate classes with respect to expected exposure to relative humidity and temperature. The relative humidity may as a rule be allowed to reach occasionally and for a short period ( $\leq 1$  week) the RH value defining the next climate class.

Note. The following grouping of structures with respect to climate conditions serves as guideline, but local conditions may call for a different grading.

Assigned to climate 1H: Structures in permanently heated buildings without air conditioning.

Assigned to climate 1 : Roof structures in ventilated, cold spaces on top of a (permanently) heated building. External walls, inside a ventilated wall covering.

Assigned to climate 2 : Structures in ventilated but not permanently heated buildings, e.g. recreation houses, garages and store houses, other covered structures not exposed to weather.

Assigned to climate 3 : Structures exposed to weather or water otherwise, e.g. scaffolding, concrete formwork, sub-water constructions.

INTERNATIONAL COUNCIL FOR BUILDING RESEARCH STUDIES AND DOCUMENTATION  
WORKING COMMISSION W18 - TIMBER STRUCTURES

DIRECTIVES FOR THE FABRICATION OF LOAD-BEARING STRUCTURES OF  
GLUED TIMBER

by

A van der VELDEN, Houtinstituut, TNO, Delft  
J KUIPERS, Stevin-Laboratorium, Delft

DIRECTIVES FOR THE FABRICATION OF LOAD-BEARING STRUCTURES  
OF GLUED TIMBER

PART I GENERAL DIRECTIVES

PART II APPENDICES

- !1 glued-laminated timber
- .2 glued timber:system Kaempf ("cross-layered"?)
- .3 DSB; Trigonit
- .4 Wellsteg
- .5 built-up beams
- .6 stressed-skin panels
- .7 .....

## PART I : GENERAL DIRECTIVES

### 1. GENERAL

#### 1.1 Introduction

Part I gives general directives for the fabrication of load-bearing glued timber structures, irrespective of the character (glulam, cross-layered, plywood panels, etc.).

Directives will be given for:

- materials
- personnel
- factory-equipment
- fabrication
- quality-control

More specified directives for different types of glued structures will be given in separate appendices.

#### 1.2 Fields of application

The directives are applicable for calculated load-bearing structures made of timber and/or of timber products, where glued joints partially or wholly determine the safety.

#### 1.3 Climatic conditions

class

I	very dry		25 C	30%
II	normal	interiour		30-70 %
III	humid			70 %
IV	covered	exteriour		60-90 %
V	uncovered			
VI	very warm		25 C	

'in most cases:very dry

#### 1.4 Calculations

- .1 Structures must be calculated with respect to strength, stiffness/deformations and stability, according to the existing standards.
- .2 If necessary structures must be calculated/tested for moisture and other physical aspects, especially if they are part of climate-partitions.

#### 1.5 Conformity with drawings.

From each element under fabrication a technical drawing must be available in the production-department of the plant. Such drawings must give tolerances. The quality-control of the plant must include control of these dimensions.

#### 1.6 Trade mark

All elements must be marked in such a way that at all times after erection the productional data can be reproduced.

#### 1.7 Alterations in fabrication

Alterations in

- responsible personnel
- equipment and buildings
- working methods
- type of construction

and all other changes that may influence the quality of the product must be reported; the last two points before the change has been effected.

## 2. MATERIALS

### 2.1 Timber

#### 2.1.1 species

Suitability for application in load-bearing glued timber structures must be shown  
by experience  
or by tests

This means

demonstrated glue-ability of the timber  
timber species is available in sufficient supply of  
constant quality  
known mechanical properties.

Durability of species: minimum class IV

#### 2.1.2. grading

according to standards

#### 2.1.3. choice

Choice of timber determined by several aspects. With respect to durability:

- structural parts in direct contact with earth:  
durability class I or totally impregnated
- structures in climatological conditions of classes III or IV (see 1.3):  
durability class I or II or total impregn.
- in case of danger for insect attack:  
durability class I or II or totally impregn.

### 2.1 Glue

#### 2.2.1 types

caseine  
urea- formaldehyd  
melamine-formaldehyd or mixtures  
resorcinol-formaldehyd or mixtures  
phenolic-formaldehyd

#### 2.2.2. quality

Glues must pass the demands of DIN ..... Furthermore it should be shown that according to ASTM-D 1101 the percentage of open glue-lines of test specimens of the applied timber species and type of glue  
is not more than 10 % with casein and UF, after 1 cycle  
is not more than 5 % with other glues after 2 cycles

#### 2.2.3. choice of glue

##### a) climate class of 1.3

	glue
I	all types of 2.2.1.
II	idem
III	all types of 2.2.1 with the exception of casein and UF
IV	all types of 2.2.1 with the exception of casein
V	RF; PF; mixtures
VI	RF; PF; mixtures

- b) In "local joints" and in those cases where good pressure cannot be expected a glue with gapfilling properties must be used.

## 2.3 Plywood

### 2.3.1. species/types

Suitability for the application in load-bearing structures must be shown  
by experience  
or by tests

This means demonstrated glue-ability  
constancy of known quality and construction  
(external quality control)  
Durability of veneers and of glue lines  
Veneers: durability class IV; exception: birch  
known mechanical properties (NEN 3519)

### 2.3.2. quality

according to NEN 3278  
glue lines: at least Ext 2  
further requirements in appendices for special  
structural elements

### 2.3.3. choice of plywood

see 2.1.3.

In climate class VI: exclusively glue class Ext.2

## 2.4. Chipboard

### 2.4.1. species/types

Suitability ....., cf. 2.1.1. and 2.3.1.

Chipboard based on wood or on flax chips may be allowed, if they are special made for structural use.

### 2.4.2. quality

according to DIN or to CTB.

### 2.4.3. choice of board

In case of danger of biological attack impregnation is necessary ( G from " V 100 G " )

Application of chipboard is not allowed in climate-conditions III and V; in conditions I and II glues of the UF-type are allowed. In other cases PF, MF and UF/MF-types or iso-cyanate glues are also allowed.

## 2.5. Hardboards

## 2.6. Insulating materials

## 2.7. Metals

## 2.8. Preservations

for timber: water-borne types; acc. to NEN 3274  
for plywood: water-borne and organic-solvent types  
acc to NEN 3274

## 2.9. Fire retardants

surface treatments are allowed

## 2.10. Finishing

Finishing treatments applicated to preserve the structural parts against weathering during transport and on the building site should  
protect against blue stain  
have a flash-point above 55 C  
waterrepellent properties ( Swellograph)

3. PERSONNEL
  - .1 management
  - .2 graders
  - .3 drying personnel
4. EQUIPMENT
  - .1 buildings
    - timber workshop
    - glue-preparation room
    - production hall
    - finishing hall
  - .2 machinery and apparatus
    - wood working machinery
    - glueing machine
    - press-equipment
    - humidity measuring
5. FABRICATION
  - condition of materials
  - preparation of glue
  - conditions during pressing
  - finishing
  - storage; transportation
  - preservation
6. QUALITY CONTROL
  - by the manufacturer
  - . by the controller of the Committee of Certification

INTERNATIONAL COUNCIL FOR BUILDING RESEARCH STUDIES AND DOCUMENTATION  
WORKING COMMISSION W18 - TIMBER STRUCTURES

COMMENTS ON DOCUMENT CIB-W18/5-100-1,  
DESIGN OF SOLID TIMBER COLUMNS

by

H J LARSEN and E THEILGARD  
Institutet for Bygningsteknik  
Aalborg Universitetscenter  
Denmark

Aalborg, Denmark - June 1976

Lehrstuhl für  
Ingenieurholzbau u. Baukonstruktionen  
Universität (TH) Karlsruhe  
Prof. Dr.-Ing. K. Möhler

Comments to  
CIB-TIMBER STANDARD NO. 02, DESIGN OF SOLID TIMBER COLUMNS

At the October-meeting in Karlsruhe a draft, dated 750901, for the design of solid timber columns was presented.

As an objection against the draft was mentioned that it was based on a sinusoidal moment curve, and that the conditions in for example eccentrically loaded columns deviated to such extent that they could not reasonably be calculated in accordance with the draft.

We have looked into the problem, cf. the enclosure.

The result can be summarized as follows:

The draft of 750901 was based on the interaction formula\*

$$(1 - k_1 \frac{f_c}{f_b}) \frac{\sigma_c}{f_c} + \frac{\sigma_c}{f_b} \cdot \epsilon \frac{k_E}{k_E - \frac{\sigma_c}{f_c}} = 1 \tag{a}$$

in which was inserted

$$\epsilon = \frac{\sigma_b}{\sigma_c} + k_1 + k_2 \lambda \tag{b}$$

To take the shape of the moment curve into consideration the following should be inserted instead

$$\epsilon = \frac{\sigma_b}{\sigma_c} [1 + \frac{\sigma_c}{f_c k_E} (\alpha - 1)] + k_1 + k_2 \lambda \tag{c}$$

where  $\alpha$  is given in fig. 1 dependent on the shape of the moment curve.

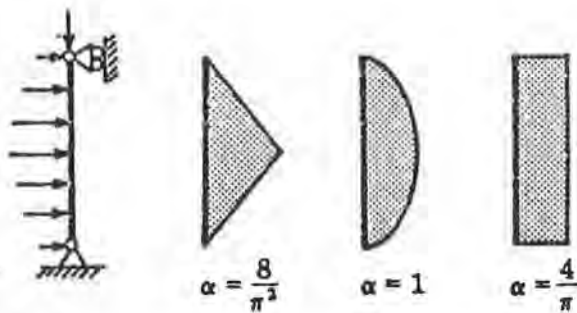

Fig. 1

In (c) the moment from the own eccentricity and initial curvature of the column is assumed to vary sinusoidally. Assuming this moment curve to consist of a constant part corresponding to  $k_1$  and a sinusoidal part corresponding to  $k_2 \lambda$ ,  $k_1$  should in (c) be replaced by

$$k_1 (1 + \frac{4 - \pi}{\pi} \frac{\sigma_c}{f_c k_E})$$

The influence of this alteration, however, is negligible.

\* For notations, refer to Timber Standard.

The influence of the various forms of moment curves is shown on fig. 2 with typical parameter values.

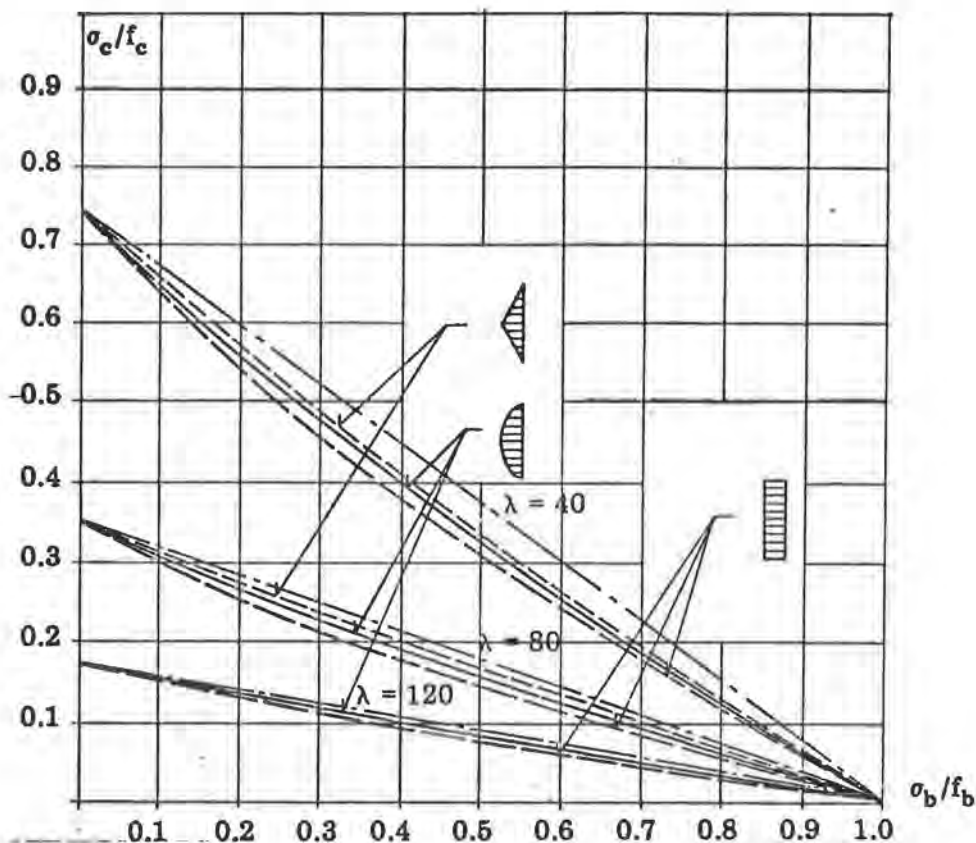

Fig. 2

In cases where - as in the Nordic countries - just a few wood species all having the same  $v$ -value are used, the code might be based on the formulas (a) and (c), as they could be given in a single diagram, like fig. 2. Here interpolation is fairly easy also for other moment distributions. In countries, however, where a wider selection of wood species are used for construction purposes it will be rather impracticable. And in fact it does not seem reasonable taking into consideration that most countries till now just have applied an interpolation corresponding to a straight line between  $\sigma_c/f_c = \sigma_{crit}/f_c$  and  $\sigma_b/f_b = 1$ . In this relation the error by using the formulas (a) and (b) as a basis, i.e. on fig. 2 the middle curve for each  $\lambda$ -value corresponding to sinusoidal deflection, is negligible. Here, the uncertainty in the assumptions and knowledge of material parameters should also be taken into account.

As a consequence, it is suggested to base the design of solid timber columns on the enclosed 2nd draft.

TIMBER BEAM-COLUMNS. INFLUENCE OF DISTRIBUTION OF LATERAL LOAD

In the following, Galerkin's variational method will be used to evaluate the influence of the distribution of the lateral load on the load-carrying capacity of beam-columns.

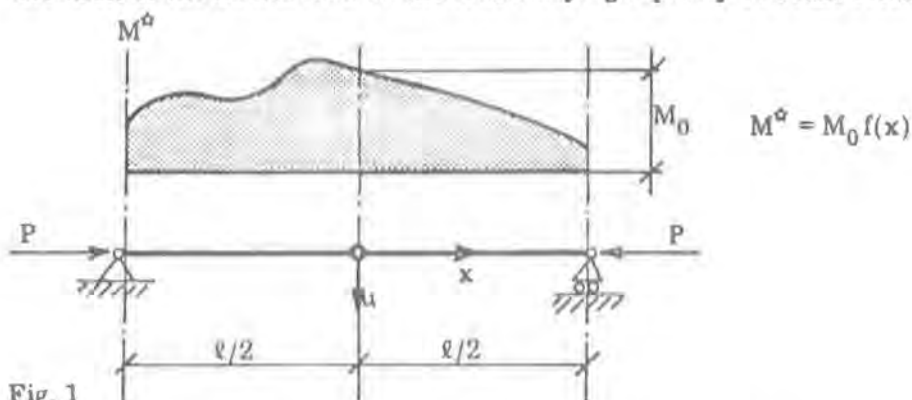

Fig. 1

The load on the beam-column shown in fig. 1 is the outer axial force  $P$  and the moment load  $M^{\star} = M_0 \cdot f(x)$ , where  $M_0$  is the moment in the middle section. The axial force is assumed to act with the eccentricity

$$e = (k_1 + k_2 \lambda \cos \frac{\pi x}{l}) \frac{W_c}{A} \tag{1}$$

where

$k_1$  and  $k_2$ : constants

$W_c$ : section modulus corresponding to compressive side

$A$ : cross-sectional area

$\lambda$ : slenderness ratio

The deflection is denoted  $u$  and the moment  $M$ . The differential equation to be solved is then:

$$EI \frac{d^2 u}{dx^2} + uP = -M = -(M^{\star} + (k_1 + k_2 \lambda \cos \frac{\pi x}{l}) \frac{W_c}{A} P) \tag{2}$$

or

$$L\{u\} = -M \tag{3}$$

where

$$L\{u\} = EI \frac{d^2 u}{dx^2} + uP \tag{4}$$

The deflection is searched as

$$u = u_0 \cos \frac{\pi x}{l} = u_0 \nu \tag{5}$$

The constant  $u_0$  is found by Galerkin's method\*\*:

$$u_0 \int_{-\frac{l}{2}}^{\frac{l}{2}} L\{\nu\} \nu dx = - \int_{-\frac{l}{2}}^{\frac{l}{2}} M \nu dx \tag{6}$$

\* Institute of Building Technology and Structural Engineering, Aalborg University Centre, Denmark.

\*\* See e.g.: L. Collatz: »The numerical treatment of differential equations». Springer-Verlag, Berlin 1966.

$$\begin{aligned}
 & -u_0 \left( EI \left( \frac{\pi}{l} \right)^2 - P \right) \int_{-\frac{l}{2}}^{\frac{l}{2}} \cos^2 \frac{\pi x}{l} dx \\
 & = - \int_{-\frac{l}{2}}^{\frac{l}{2}} M^* \cos \frac{\pi x}{l} dx - P k_1 \frac{W_c}{A} \int_{-\frac{l}{2}}^{\frac{l}{2}} \cos \frac{\pi x}{l} dx - P k_2 \lambda \frac{W_c}{A} \int_{-\frac{l}{2}}^{\frac{l}{2}} \cos^2 \frac{\pi x}{l} dx \quad (7)
 \end{aligned}$$

$$u_0 (P_E - P) \frac{\pi}{2} = M_0 \int_{-\frac{l}{2}}^{\frac{l}{2}} f(x) \cos \frac{\pi x}{l} d \frac{\pi x}{l} + 2k_1 \frac{W_c}{A} + k_2 \lambda \frac{W_c}{A} \frac{\pi}{2} \quad (8)$$

$$u_0 = \frac{M_0 \alpha + \frac{4}{\pi} k_1 \frac{W_c}{A} P + k_2 \lambda \frac{W_c}{A} P}{P_E - P} \quad (9)$$

where  $P_E = \frac{\pi^2 EI}{l^2}$  is the Euler load and

$$\alpha = \frac{2}{\pi} \int_{-\frac{l}{2}}^{\frac{l}{2}} f(x) \cos \frac{\pi x}{l} d \frac{\pi x}{l} \quad (10)$$

The value of  $\alpha$  for different moment distributions is shown in fig. 2.

The resulting bending moment  $M_r$  in the middle section then becomes

$$\begin{aligned}
 M_r & = M^* + \left( k_1 \frac{W_c}{A} + k_2 \lambda \frac{W_c}{A} \right) P + uP = \\
 & M_0 + P k_1 \frac{W_c}{A} + P k_2 \lambda \frac{W_c}{A} + P \frac{\alpha \frac{\sigma_b}{\sigma_c} + \frac{4}{\pi} k_1 + k_2 \lambda}{P_E - P} \frac{W_c}{A} P \\
 & \equiv \frac{\frac{\sigma_b}{\sigma_c} \left( 1 + \frac{\sigma_c}{\sigma_E} (\alpha - 1) \right) + k_1 \left( 1 + \frac{\sigma_c}{\sigma_E} \frac{4 - \pi}{\pi} \right) + k_2 \lambda}{1 - \frac{\sigma_c}{\sigma_E}} \frac{W_c P}{A} \quad (11)
 \end{aligned}$$

$\sigma_b = M_0/W_c$  is the bending stress in the middle section from lateral loads and  $\sigma_c = P/A$  is the compressive stress. The corresponding strength parameters are  $f_b$  and  $f_c$ .  $\sigma_E = P_E/A$  is the Euler stress.

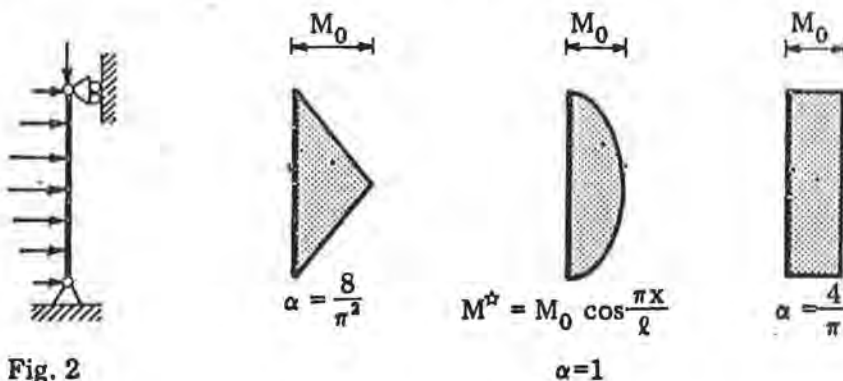

Fig. 2

The correct value of the relative eccentricity,  $\epsilon$ , to be inserted in eq. (11) in: H. J. Larsen: »The design of solid timber columns», Aalborg University Centre, 1974, then becomes

$$\epsilon = \frac{\sigma_b}{\sigma_c} \left(1 + \frac{\sigma_c}{f_c k_E} (\alpha - 1)\right) + k_1 \left(1 + \frac{\sigma_c}{f_c k_E} \frac{4 - \pi}{\pi}\right) + k_2 \lambda \quad (12)$$

where  $k_E = \sigma_E / f_c$ .

Solution of the above-mentioned eq. (11) with regard to  $\sigma_b / f_c$  gives

$$\frac{\sigma_b}{f_b} = \left( (1 - \psi) \frac{\sigma_c}{f_c} \frac{k_E - \frac{\sigma_c}{f_c}}{k_E} - \frac{f_c}{f_b} \frac{\sigma_c}{f_c} \left( k_1 \left( 1 + \frac{\sigma_c}{f_c k_E} \frac{4 - \pi}{\pi} \right) + k_2 \lambda \right) \right) / \left( 1 + \frac{\sigma_c}{f_c k_E} (\alpha - 1) \right) \quad (13)$$

where

$$\psi = 1 - k_1 \frac{f_c}{f_b}$$

Eq. (13) gives furthermore a quadratic equation from which  $\sigma_c / f_c$  can be derived.

INTERNATIONAL COUNCIL FOR BUILDING RESEARCH STUDIES AND DOCUMENTATION  
WORKING COMMISSION W18 -- TIMBER STRUCTURES

CIB TIMBER CODE  
CIB TIMBER STANDARDS  
FIRST DRAFT 76.04.20

76.04.20

## P R E F A C E

The present draft for a CIB-Timber Code has been prepared for the purpose of creating a background for a realistic discussion in the CIB-W18-Timber Structures on the possibilities of transforming the calculation work done so far into an actual code draft, including attitude to the contents in principle, setting up a working schedule, and ensuring the necessary means.

The individual chapters have very different degrees of completion. Some of them, e.g. chapter 5, show how far the group has come in certain fields. Others demonstrate - being very rough or empty - where considerable effort has yet to be set in. This applies to e.g. chapter 4. Others again are intended to force the group from theoretical discussions to practical decision. This applies to e.g. chapter 2.3.

Furthermore, all the chapters should form the basis for e.g. discussing the division in actual code text, guiding text and comments, and the principle of referring to standards, etc.

This work has been made possible by *The Danish Building Research Institute*, which has given financial background for employing an engineer (Esko Theilgaard) for 4 hours a day in 4 months, and in addition some secretarial assistance, etc.

To utilize the money in the best way we have abstained from trimming the language and have written on in our national version of English.

We hope that it will be possible through CIB-W18 to procure the necessary manpower and means so that the work can be taken over by others.

H. J. Larsen

Esko Theilgaard

## CONTENTS

## 1. INTRODUCTION

- 1.1 Scope
- 1.2 Conditions for the validity of this document
- 1.3 Units
- 1.4 Notations
- 1.5 Definitions

## 2. BASIC ASSUMPTIONS

- 2.1 Characteristic values
- 2.2 Climate classes
- 2.3 Load-duration classes

## 3. BASIC DESIGN RULES

- 3.0 General
- 3.1 Design principles
  - 3.1.0 General
    - 3.1.1 Design by calculation
    - 3.1.2 Design by testing
- 3.2 Limit states
  - 3.2.0 General
    - 3.2.1 Ultimate limit states
    - 3.2.2 Special ultimate limit states
    - 3.2.3 Serviceability limit states
    - 3.2.4 Other limit states
- 3.3 Safety against reaching ultimate limit states
- 3.4 Deflections

## 4. MATERIAL SPECIFICATIONS AND CHARACTERISTIC VALUES (NOT YET PREPARED)

- 4.0 General
  - 4.0.0 General claims and regulations in connection with material specifications
  - 4.0.1 Testing
    - 4.0.1.1 Sampling
    - 4.0.1.2 Preparation, conditioning and storing of samples
    - 4.0.1.3 Execution of tests
    - 4.0.1.4 Documentation
  - 4.0.2 Evaluation of test results and calculation of characteristic values
- 4.1 Prismatic members of wood
  - 4.1.0 General
    - 4.1.1 Timber
      - 4.1.1.0 General, including claims of tolerances, etc.
        - 4.1.1.1 Special conditions in connection with material specifications including grading principles (visual, mechanical)
        - 4.1.1.2 Special conditions in connection with testing
        - 4.1.1.3 Special conditions in connection with determination of characteristic values

## Appendices

Data sheets for different timber grades prepared according to a standard lay-out and containing grading rules, approved characteristic values for a standard condition (for example dry condition, long-term load, beam depth up to 250 mm, etc.), and non-standard modification factors.

- 4.1.2 End-glued timber (finger-jointed, scarf-jointed)<sup>☆</sup>
- 4.1.3 Glued laminated timber<sup>☆</sup>
- 4.2 Sheet materials (panel products)
  - 4.2.0 General
  - 4.2.1 Plywood<sup>☆</sup>
  - 4.2.2 Particle boards<sup>☆</sup>
  - 4.2.3 Fibre boards<sup>☆</sup>
- 4.3 Mechanical fasteners
  - 4.3.0 General
  - 4.3.1 Nails<sup>☆</sup>
  - 4.3.2 Screws<sup>☆</sup>
  - 4.3.3 Bolts and dowels<sup>☆</sup>
  - 4.3.4 Connectors<sup>☆</sup>
  - 4.3.5 Nail plates<sup>☆</sup>
- 4.4 Other materials<sup>☆☆</sup>
  - 4.4.0 General
  - 4.4.1 Glue

## 5. DESIGN OF BASIC MEMBERS

- 5.1 Prismatic members
  - 5.1.0 General
    - 5.1.1 Solid timber
      - 5.1.1.0 General
      - 5.1.1.1 Tension
      - 5.1.1.2 Compression
      - 5.1.1.3 Bending
      - 5.1.1.4 Shear
      - 5.1.1.5 Tension and bending
      - 5.1.1.6 Compression and bending
      - 5.1.1.7 Columns
    - 5.1.2 Glued laminated timber
      - 5.1.2.0 General
        - 5.1.2.1
        - 5.1.2.2 (void)
        - 5.1.2.3
        - 5.1.2.4 Shear
        - 5.1.2.5
        - 5.1.2.6 (void)
        - 5.1.2.7
        - 5.1.2.8 Curved members
        - 5.1.2.9 Cambered beams, straight or pitched
- 5.2 Plane members (not yet prepared)
  - 5.2.0 General
  - 5.2.1 Plywood
  - 5.2.2 Particle boards
  - 5.2.3 Fibreboards
- 5.3 Joints with mechanical fasteners (not yet prepared)
  - 5.3.0 General
  - 5.3.1 Nailed joints

<sup>☆</sup> Subdivision and the use of data sheets as for timber (section 4.1.1). For fasteners the data sheets also give the structural rules being the condition for the given characteristic values.

<sup>☆☆</sup> Subdivision as appropriate.

- 5.3.2 Screwed joints
- 5.3.3 Bolted or dowelled joints
- 5.3.4 Connected joints
- 5.3.5 Joints with nail plates
- 5.4 Glued joints (not yet prepared)
- 5.5 Other basic elements (not yet prepared)

## 6. DESIGN OF COMPONENTS

- 6.1 Glued components
  - 6.1.1 Beams
    - 6.1.1.1 Laminated beams
    - 6.1.1.2 Thin-webbed beams
    - 6.1.1.3 Thin-flanged beams (stiffened plates)
  - 6.1.2 Columns
    - 6.1.2.1 Laminated columns
    - 6.1.2.2 I- and box columns
    - 6.1.2.3 (void)
    - 6.1.2.4 Spaced columns
    - 6.1.2.5 Lattice columns
- 6.2 Mechanically jointed components
  - 6.2.0 General
  - 6.2.1 Beams
  - 6.2.2 Columns

## 7. DESIGN OF SPECIAL STRUCTURES

- 7.1 Arches, portals and frames
- 7.2 Trusses

## 8. CONSTRUCTION

- 8.0 General
- 8.1 Materials
- 8.2 Machining
- 8.3 Joints
- 8.4 Assembly
- 8.5 Transportation
- 8.6 Erection

## 9. CONTROL (NOT YET PREPARED)

### CIB-TIMBER STANDARDS :

- 01 DESIGN OF SOLID TIMBER COLUMNS
- 02 MECHANICALLY JOINTED BEAMS AND COLUMNS WITH I-, T- OR BOX SECTIONS
- 03 SPACED COLUMNS WITH NAILED OR GLUED PACKS OR BATTENS
- 04 LATTICE COLUMNS WITH GLUED OR NAILED JOINTS
- 05 TESTING OF TIMBER STRUCTURES

## 1. INTRODUCTION

### 1.1. Scope

The primary purpose of this code is to provide an agreed background for international bodies and various national committees in formulating timber codes, i.e. sets of requirements aiming to ensure a reasonable quality of timber structures.

The code relates primarily to the structural use of timber and is intended for use in the design, execution and appraisal of structural elements made from timber or wood products and of structures substantially composed of such elements.

It is based on the principles of structural mechanics, engineering design, and experimental data, interpreted statistically as far as possible.

Deviations from the requirements of this code and the use of materials and methods of design or construction of wood structures not covered by this code are permitted when the soundness hereof is substantiated by analytical and engineering principles or reliable test data, or both, which demonstrate that the safety of the resulting structure for the purpose intended is equivalent to the safety demanded in this code.

### 1.2. Conditions for the validity of this document

Since safety and serviceability are not simply functions of design, but depend also on the care and skill of all personnel involved in the construction process, and on the proper use and maintenance of the structure, it is required that

- projects are carried out by qualified engineers,
- the construction is carried out by personnel having both the required skill and experience,
- the required supervision is always available,
- the structure by design or the use of suitable materials or by impregnation is protected against attack by fungi, insects, shipworm, gribble, etc.,
- the actual conditions of use of the structure during its life do not depart significantly from those specified during the design stage, and
- the maintenance of the structure during its intended life is ensured.

### 1.3. Units

The units used are in accordance with the «International System of Units S. I.» and «Rules for the Use of the International System of Units» established by ISO and prepared by ISO/TC98/SC 2.

: Accordingly, the following basic units and units and multiples derived from them are used.

Table 1.3. Survey of units

size	unit		
	designation		multiples
length	metres	m	mm
area	square metres	m <sup>2</sup>	mm <sup>2</sup>
force (load)	newton	N	kN
moment	newtonmetre	Nm	kNm
stress, modulus of elasticity	pascal = newton per square metre	1 Pa = 1 N/m <sup>2</sup>	1 MPa = 1 N/mm <sup>2</sup>
force per length	newton per metre	N/m	kN/m
force per area	pascal = newton per square metre	1 Pa = 1 N/m <sup>2</sup>	1 kPa = 1 kN/m <sup>2</sup>

Only multiples of 10<sup>3n</sup>, e.g. MN, kN, N, are used.

#### 1.4. Notations

The notations used are in accordance with Draft International Standard ISO/DIS 3898.

The following general terms and symbols are used. Symbols which are not explained here are defined when used.

Will be prepared at completion of the work.

**1.5. Definitions**

Will be prepared at completion of the work.

## 2. BASIC ASSUMPTIONS

### 2.1 Characteristic strength and stiffness values

The variation of the strength and stiffness is treated by defining characteristic values related to some standard test specimens and procedures on a statistical basis.

In this code the characteristic strength and stiffness values used for strength calculations are determined as the 5%-fractile, i.e. 95% of all possible test results exceed the characteristic values. For other stiffness parameters they are defined as the mean value.

As these values cannot be determined exactly from a final number of measurements it is demanded that the possibility of accepting a result not satisfying the demand, should not exceed 25% (confidence level > 75%).

The dependence of the characteristic values on the duration of load and the moisture content of the structure should be taken into consideration.

## 2.2 Climate classes

In the following it is assumed that the structures depending on the moisture content are grouped in the following climate classes:

- : The climate classes are summarized in table 2.2, which also gives the approx. moisture content of ordinary softwood.

Table 2.2 Climate grading

climate class	0	1	2	3
relative humidity (RH)	$RH_{\text{mean}} < 0.40$	$RH < 0.65$	$RH < 0.85$	no limit
approx. moisture content of softwood ( $\omega$ )	$\omega < 0.08$	$\omega < 0.12$	$\omega < 0.20$	no limit

### Climate class 0

The moisture content corresponds to an average annual relative humidity not exceeding 40%.

- : This climate class corresponds to conditions in permanently heated buildings without artificial air-moistening.

### Climate class 1

The moisture content corresponds to conditions in which the relative humidity of the surrounding air only exceptionally, and then only for short periods (a few days), exceeds 65%.

- : The following structures can be included in this class:
  - roof structures in cold, but ventilated attics over permanently heated buildings,
  - boards in outer walls in permanently heated buildings where the boards are protected by a well-ventilated tight cladding.

### Climate class 2

The moisture corresponds to conditions in which the relative humidity of the surrounding air only exceptionally, and then only for short periods (a few days), exceeds 85%.

- : The following structures can be included in this class:
  - structures in not permanently heated, but ventilated, buildings in which no activities particularly likely to give rise to moisture take place, for example, holiday houses, unheated garages and warehouses, together with service space,
  - outer roof boarding,
  - scaffolding, concrete formwork and similar temporary structures.

### Climate class 3

All other climatic conditions.

### 2.3 Load-duration classes

In the following strength and stiffness values are given corresponding to an accumulated duration of full or almost full design load as shown in table 2.3. Furthermore, strength parameters corresponding to very brief loadings are given.

Table 2.3 Load-duration classes

load-duration class	duration	typical examples for permanent structures <sup>☆</sup>
permanent		dead load, earth pressure, load on tanks
normal	< 10 years accumulated	floor loads, normal snow load in some countries, normal traffic load on bridges
short-term	< 7 days accumulated	exceptional snow load in some countries, normal wind loads, live load on most scaffolds, concrete shuttering and framework
instantaneous	< 3 seconds per loading	exceptional wind loads, impact, earthquake, mooring forces (ships)

<sup>☆</sup> From the code of loads and the rheological conditions of the materials it is determined to which class a load belongs.

### 3. BASIC DESIGN RULES

#### 3.0 General

The aim of the design is to achieve the probability that the structure being designed will not become unfit for the use for which it is required during its intended life.

A structure, or part of a structure, is considered unfit for use when it reaches a particular state, called a limit state in which it infringes one of the criteria governing its performance or use.

All relevant limit states should be considered in the design in order to ensure an adequate degree of safety and serviceability.

Loads are assumed to be determined in accordance with current national or international rules taking into account the stresses that might occur due to the deformations caused by moisture .

- : For European softwoods the change in cross-sectional dimensions may as a rough mean value be taken as 0.2%
- : for a change in moisture content of 0.01 within the 0.10-0.30 moisture content interval. Changes in the longitudinal direction may similarly be taken as 0.01%.

### 3.1 Design principles

#### 3.1.0 General

The verification that a limit state is not reached can be made by calculation or test.

For simple structural elements and joints for which characteristic strength values and design methods are given in this code the verification should be made by calculation or proof testing.

#### 3.1.1 Design by calculation

Investigation of the strength and stiffness of a structure or structural member can be carried out by a theory of elasticity (linear/non-linear - isotropic/anisotropic) or by a theory of plasticity in conformity with the response of the materials and structures to load and imposed deformations.

- : It might occur that it is most appropriate to use both theory of plasticity and theory of elasticity in the analysis of a structure. As an example the theory of plasticity will often give the best description of the internal forces in the members in a structure, where the structural members are connected by mechanical fasteners, while in the members the stress distribution for the internal forces found can be calculated in the best way by the linear theory of elasticity. Note in this connection that the formulas of the theory of elasticity have been used to calculate the strength and stiffness parameters found by tests and given in section 4.

The cross-sectional dimensions to be applied should be either the minimum cross-section acceptable for any given nominal size as specified in the standard grading rules applying to the timber, or the actual cross-section as measured. For structural timber, where the difference between nominal dimensions and the real dimensions is within the limits given in chapter 4, the calculations can be made with the nominal dimensions.

In strength calculations should, unless otherwise specified, the reduction in area caused by all features such as sinkings, notches, bolt or screw-holes, mortices, etc. at that section or within a distance either side of the section equal to twice the larger cross-sectional dimension of the member be taken into consideration.

#### 3.1.2 Design by test

Design by test can be used for both proof testing and prototype testing.

- : *Proof testing* is the application of test loads to a structure or element to ascertain the structural characteristics of only the one unit under test.
- : *Prototype testing* is the application of test loads to a structure or element to ascertain the structural characteristics of structures or elements which are nominally identical to the unit or units tested.

Test of a structure or structural member should be designed, supervised, certified and evaluated by a competent body approved by the authority entitled to give their approval of the structure(s).

The test load should be both applied and resisted in a manner approximating reasonably to the actual service conditions and on no account be such as to lead to an overestimate of the load-carrying capacity of the structure.

- : For ordinary structures these demands can be considered satisfied if the CIB-Timber Standard 05 is obeyed.

In evaluation of test results account should be taken of the influence of the difference between test-loading time and real loading time.

For prototype testing where the test specimens are loaded to destruction the characteristic load-carrying capacity should be calculated on the basis of approved statistical methods. Apart from the measured ultimate loads previous knowledge of e.g. distribution function and coefficient of variation for similar structures may be included in the calculations.

: If no information but the test results is available the 5% characteristic strength value  $K_k$  can be calculated as

:

$$K_k = K_{u,m} - \alpha \cdot s$$

:

: where  $K_u$  is the ultimate load for a single specimen,  $K_{u,m}$  is the mean value of  $K_u$ ,  $s$  is the standard deviation of  $K_{u,m}$  and  $\alpha$  is a coefficient depending on the number of tested specimens ( $n$ ) as follows:

:

$n$	4	5	10	15
$\alpha$	2.7	2.5	2.1	2.0

:

: The above values correspond to a normal distribution and a confidence level of 75%, cf. section 2.1

For prototype testing where the test specimens are not loaded to destruction but only to a maximum load  $K_{max}$ , where the construction is not seriously damaged, the characteristic short-term load-carrying capacity can be assumed as  $0.9 K_{max}$  for a minimum of 5 tests.

For proof testing the characteristic short-term load-carrying capacity can be assumed as  $K_{max}$ , where  $K_{max}$  is the applied maximum load

If according to the specification the deflection of the structure under the design load is limited ( $a_{lim}$ ) the deflection after 24 h duration under the test load  $Q_d$  must not exceed  $\beta a_{lim}$ , where the value of the coefficient  $\beta$  is determined with regard to the creep properties of the material.

- : Provided the test results do not indicate that other values should be preferred, the following values of  $\beta$  can be used:
- : For timber structures with mechanical joints tested to be used in climate class 1:  $\beta = 0.7$ .
- : For glued structures of plywood and timber in combination to be used in climate class 0:  $\beta = 0.8$ .

### 3.2 Limit states

#### 3.2.0 General

The limit states can be placed into three categories:

- a) the ultimate limit states which are those corresponding to the maximum load-carrying capacity;
- b) the special ultimate limit states, which are those corresponding to the load-carrying capacity under the assumption that certain parts of the structure have ceased to perform their load-carrying functions;
- c) the serviceability limit states, which are related to the criteria governing normal use and durability.

#### 3.2.1 Ultimate limit states

The ultimate limit states may be reached due to:

- a) loss of equilibrium of a part or the whole structure considered as a rigid body,
- b) rupture, or excessive plasticity, of critical sections of the structure possibly due to fatigue,
- c) transformation of the structure into a mechanism,
- d) elastic or plastic instability, including buckling.

#### 3.2.2 Special ultimate limit states

The special ultimate limit states can be placed into two categories:

- a) Progressive collapse where the entire or essential parts of a structure reach an ultimate state in consequence of part of them locally reaching a limit state or not contributing as assumed.
  - : No structures can be expected to be resistant to the excessive actions that could arise due to an extreme cause,
  - : but it should not be damaged to an extent disproportionate the the original cause.
- b) Fire. This limit state is not dealt with in detail in this code. It is assumed that the demands to fire fire resistance are laid down by appropriate (governmental) bodies as functions of the use of the building.
  - : Only for a few constructions it is possible to deal theoretically with the response of structural systems to fire and its effects.
  - : As an example can be mentioned that the load-carrying capacity of a prismatic member subsequent to fire can be calculated on the basis of the remaining cross-section, which can be determined from the charring speed for the wood in question. For European softwood, unless otherwise laid down nationally, a charring speed of 0.6 mm/minute can be assumed.

#### 3.2.3 Serviceability limit states

The serviceability limit states may be reached due to:

- a) Excessive deflections influencing the appearance or efficiency of the structure.
- b) Local damages which might entail excessive maintenance or lead to corrosion, rot attack, etc.

#### 3.2.4 Other limit states

Where a structure is designed for some special or unusual function other criteria may be introduced to define appropriate limit states.

### 3.3 Safety against reaching limit states

In the following the safety against reaching a limit state is assumed to be ensured by using a consistent system of partial coefficients in accordance with current national and international rules, among others International Standard ISO 2394.

- : According to the partial coefficient system the characteristic loads are transformed to design loads by multiplication by load factors (the factor of load no.  $i$  is denoted  $\gamma_{fi}$ ) and the characteristic material values are transformed to design values by division by material factors (the factor of material parameter no.  $j$  is denoted  $\gamma_{mj}$ ).
- : The load-carrying capacity expressions given in the following assume that material factors are used on all material parameters (also moduli of elasticity).
- : Only apparently, a position on the safety system (partial coefficient system versus allowable stresses) has been taken, since the system with allowable stresses with a factor  $\gamma$  is just a special case of the partial coefficient system obtained by setting  $\gamma_{fi} = 1$  and  $\gamma_{mj} = \gamma$ .
- : When partial coefficients are used design material values are inserted in the load-carrying capacity expressions which immediately give the design load-carrying capacity. When allowable stresses are used characteristic material values are inserted, and the load-carrying capacity expressions then give the characteristic load-carrying capacity which is divided by  $\gamma$  to get the permissible load-carrying capacity.

### 3.4 Deflections

Under the most adverse loading, the deflections of a structure shall not impair the strength and serviceability of the structure or any part thereof, nor cause damage to other building components.

- : Guiding values for acceptable deformations are given in Draft International Standard ISO/DIS . . . . , but it should
- : be noted that for aesthetic reasons stricter rules might be called for.
- : Part of the effect of deflections can be met by provision of camber.
- : In the calculation of deflections the influence of loading time, moisture content and slip of joints should be taken
- : into account.
- : (Attention is called to the fact that the moduli of elasticity in bending given in section 4 are true values and not
- : reduced to take into account the possible contribution of the shear forces to the deflections. Such contributions
- : should when necessary be calculated separately).

4. MATERIAL SPECIFICATIONS AND CHARACTERISTIC VALUES

(NOT YET PREPARED)

## 5. DESIGN OF BASIC MEMBERS

### 5.1 Prismatic members

#### 5.1.0 General

In this section prismatic members <sup>also (e.g.)</sup> also comprise cylindrical and slightly conical members, e.g. timber logs and poles.

For the purpose of calculating the strength of a member at any section due allowance should be made for reduction in area caused by all features, etc. at that section or within a distance either side of the section equal to twice the larger cross-sectional dimension of the member.

Cross-sectional reductions caused by nails and screws with a diameter or side length smaller than 6 mm may be disregarded.

The effective span of flexural members shall be taken as the distance between the centres of areas of bearing. With members extending over bearings longer than is necessary, the span may be measured between centres of bearings of a length which would be adequate according to this code; due attention should be paid to the eccentricity of the load where advantage is taken of this provision.

#### 5.1.1 Solid timber

##### 5.1.1.0 General

Stresses caused by bending and axial force should be determined on the basis of the ordinary technical theory of elasticity.

- : The reason for this is primarily that the strength parameters given have been determined on the basis of this
- : theory.

Possible unfavourable influences from initial curvature, eccentricities, etc. should be taken into account.

##### 5.1.1.1 Tension

For tension in the grain direction it must be verified that the stresses satisfy the following condition:

$$\sigma_t \leq f_t \quad (5.1.1.1)$$

##### 5.1.1.2 Compression

For compression at an angle  $\theta$  to the grain it must be verified that the stresses satisfy the following condition

$$\sigma_c \leq f_{c\parallel} - (f_{c\parallel} - f_{c\perp}) \sin^2 \theta \quad (5.1.1.2 a)$$

cf. fig. 5.1.1.2 a.

It is assumed that the structural member is prevented from deflection.

- : Thus, the stated term solely ensures that the compressive stress directly under the load is acceptable, but not
- : that an element in compression can carry the load in question. Reference is made to the section on columns.

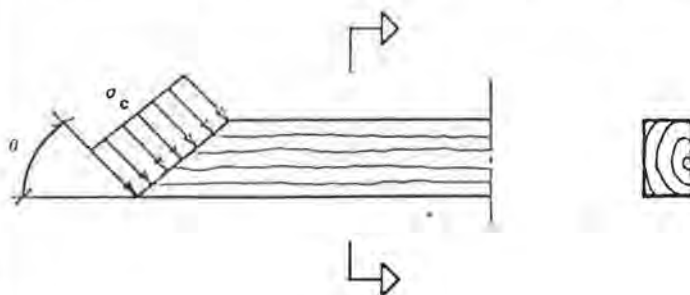

Fig. 5.1.1.2 a

For bearings on the side grain ( $\theta = 90^\circ$ ) formula (5.1.1.2 a) may be replaced by

$$\sigma_c \leq k_{\text{bearing}} f_{c1} \tag{5.1.1.2 b}$$

For bearings located at least 75 mm and 1.5 h from the end  $k_{\text{bearing}}$  may be taken from fig. 5.1.1.2 b. In other cases  $k_{\text{bearing}} = 1$ .

Where the deformations resulting from compression perpendicular to the grain are significant to the function of a structure, an estimate of the deformations must be made.

- : See e.g. G. Backsell: Experimental investigations into deformations resulting from stresses perpendicular to the grain. Report 12/66 from The Building Research Institute, Stockholm.

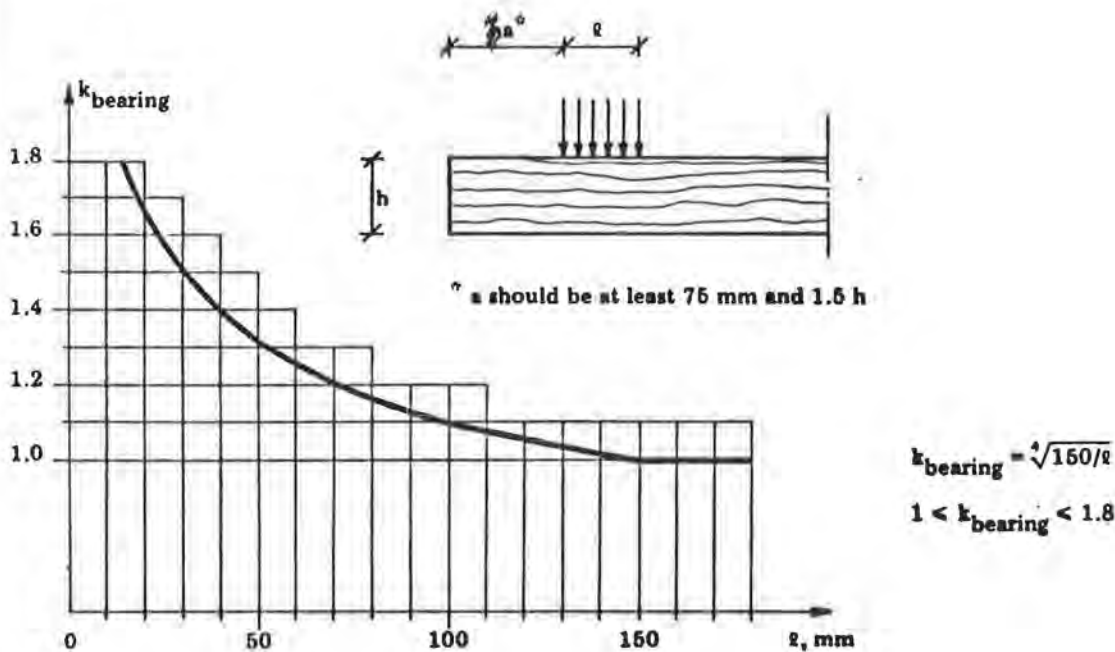

Fig. 5.1.1.2 b

5.1.1.3 Bending

For pure bending with the bending stresses  $\sigma_b$  calculated according to the ordinary theory of elasticity it must be verified that

$$\sigma_b \leq k_{\text{inst}} f_b \tag{5.1.1.3 a}$$

where  $k_{\text{inst}}$  is a factor ( $\leq 1$ ) taking into account the reduced strength due to failure by lateral instability (lateral buckling).

The strength reduction, i.e.  $k_{\text{inst}} = 1$ , may be disregarded if

$$\lambda_b = \sqrt{f_b / f_{b,\text{crit}}} \leq 0.75 \tag{5.1.1.3 b}$$

In (5.1.1.3 b)  $\lambda_b$  is the slenderness ratio for bending, and  $f_{b,\text{crit}}$  is the critical bending stress calculated according to the classical theory of stability.

$k_{\text{inst}}$  may also be put equal to 1 for beams with rectangular cross-section and a depth-to-width ratio less than or equal to 2 ( $h/b \leq 2$ ).

CONSEIL INTERNATIONAL DU BÂTIMENT \* INTERNATIONAL COUNCIL FOR BUILDING RESEARCH STUDIES AND DOCUMENTATION

$k_{inst}$  is determined so that the total bending stresses, determined in consideration of the influence from initial curvature, eccentricities and the deformations developed, do not exceed  $f_b$ .

- : For a beam with rectangular cross-section  $k_{inst}$  can be determined from fig. 5.1.1.3 a dependent on the slender-
- : ness ratio  $\lambda_b$ , which in this case is determined from

$$\lambda_b = \sqrt{\frac{\varrho_e h f_b}{b^2 E}} \tag{5.1.1.3 c}$$

- : where  $\varrho_e$  is the effective length of the beam. For a number of structures and load combinations  $\varrho_e$  is given in table
- : 5.1.1.3 in relation to the free beam length  $\varrho$ .
- : The free length is determined as follows:
- : a) When lateral support to prevent rotation is provided and no other support to prevent rotation or lateral displacement is provided throughout the length of a beam, the unsupported length shall be the distance between such points of bearing, or the length of a cantilever.
- : b) When beams are provided with lateral support to prevent both rotation and lateral displacement at intermediate points as well as at the ends, the unsupported length may be the distance between such points of intermediate lateral support. If lateral displacement is not prevented at points of intermediate support, the unsupported length shall be as defined in a).
- : c) When the compression edge of a beam is supported throughout its length so as to prevent its lateral displacement, and the ends are supported as in a), the unsupported length may be taken as zero.

Table 5.1.1.3. Relative effective beam length  $\varrho_e/\varrho$

Kind of beam support and nature of load	$\varrho_e/\varrho^{**}$
Simple beam, load concentrated at centre	1.30
Simple beam, uniformly distributed load	1.50
Simple beam, equal end moments	1.55
Cantilever beam, load concentrated at unsupported end	1.25
Cantilever beam, uniformly distributed load	0.80
Simple or cantilever beam, any load (conservative value)	1.55

\* Applies to loads acting in the gravity axes. For downwards acting loads  $\varrho_e$  is increased by  $3h$  for loads on the top side and reduced by  $h$  for loads on the bottom side.

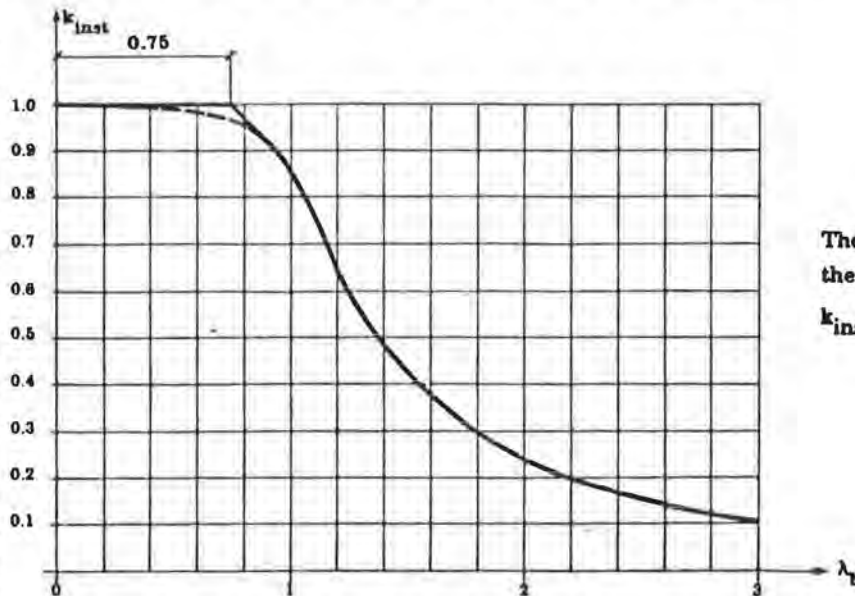

The dotted curve and its extension to the right corresponds to

$$k_{inst} = \frac{1}{1 + \frac{0.04413 \lambda_b^2}{1 - k_{inst}^2 \lambda_b^4}}$$

Fig. 5.1.1.3.

#### 5.1.1.4 Shear

It must be verified that the shear stresses satisfy the following condition

$$\tau/f_v \leq 1 \quad (5.1.1.4 a)$$

For beams with bearing in the bottom side and load on the top side load placed nearer than the beam depth from the theoretical point of support can be disregarded in calculation of the shear force.

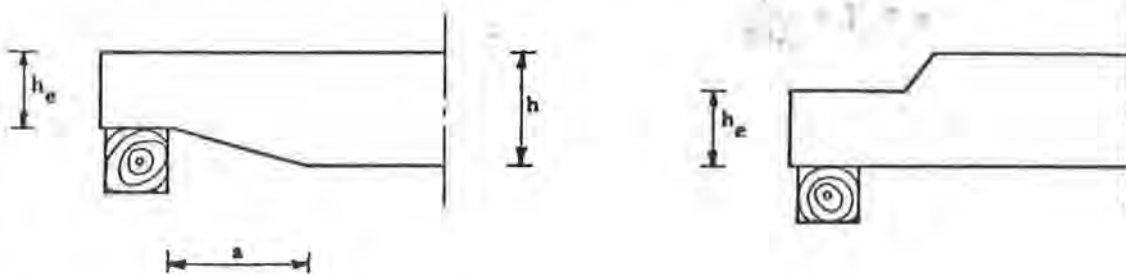

Fig. 5.1.1.4

For beams notched at the ends, see fig. 5.1.1.4, the shear stresses should be calculated on the effective depth  $h_e$ , and for notches in the bottom the condition (5.1.1.4 a) should be replaced by

$$\tau/f_v \leq k_{\text{notch}} \quad (5.1.1.4 b)$$

where

$$k_{\text{notch}} = \begin{cases} \frac{h_e}{h} \left(1 + \frac{a}{3h_e}\right) & \text{for } a \leq 3(h - h_e) \\ 1.0 & \text{for } a > 3(h - h_e) \end{cases} \quad (5.1.1.4 c)$$

#### 5.1.1.5 Tension and bending

It must be verified that the stresses satisfy the following condition

$$\frac{\sigma_t}{f_t} + \frac{\sigma_b}{f_b} \leq 1 \quad (5.1.1.5 a)$$

and in the parts of the cross-section, if any, where  $\sigma_t + \sigma_b < 0$ , furthermore

$$|\sigma_b| - \sigma_t \leq f_b \quad (5.1.1.5 b)$$

#### 5.1.1.6 Compression and bending

Only the case with compression in the grain direction is considered. The structural member is assumed prevented from deflection.

It must be verified that the stresses in the parts of the cross-section, where  $\sigma_b + \sigma_c < 0$  satisfy the following condition

$$\frac{|\sigma_c|}{f_c} + \frac{|\sigma_b|}{f_b} \leq 1 \quad (5.1.1.6 a)$$

and in the parts of the cross-section, if any, where  $\sigma_c + \sigma_b > 0$ ,

$$\sigma_b + \sigma_c \leq f_b \quad (5.1.1.6 b)$$

5.1.1.7 Columns

For columns it must be verified that the conditions in section 5.1.1.6 are satisfied, when apart from bending stresses from lateral load, if any, the bending stresses from initial curvature and eccentricities and stresses caused by the deflections are taken into consideration. This may be done by using the method given in the CIB Timber Standard 01.

For European softwood in ordinary structural qualities, unless otherwise proved to be more correct, the relative initial eccentricity can be taken as

$$\epsilon = 0.10 + 0.005 \lambda = 0,1 + \frac{\lambda}{200} \tag{5.1.1.7}$$

Design values for axially loaded columns determined by this method can be found from fig. 5.1.1.7 a assuming  $f_c/f_b = 0.8$ .

Acceptable combinations of compressive and bending stresses are given in fig. 5.1.1.7 b. It is noted that  $\sigma_b$  is the bending stress caused solely by the outer lateral load.

For the purpose of calculating the slenderness ratio of compression members, the values of the effective length  $l_c$  should be taken from table 5.1.1.7.  $l$  is the actual length of the member.

Table 5.1.1.7. Relative effective length of compression members

Condition of end restraint	$l_c/l$
Restrained at both ends in position and direction	0.7
Restrained at both ends in position and one end in direction	0.85
Restrained at both ends in position but not in direction	1.00
Restrained at one end in position and direction and at the other end partially restrained in direction but not in position	1.50
Restrained at one end in position and direction, but not restrained in either position or direction at the other end	2.00

Alternatively, the effective length may be calculated for the worst conditions of loading to which a compression member is subjected, having regard to the induced moments at the ends or along the length of the compression member. The effective length should be deemed to be the distance between two adjacent points of zero bending moment, these being two points between which the deflected member would be in single curvature.

The slenderness ratio should not exceed 170, for secondary members, however, it should not exceed 200

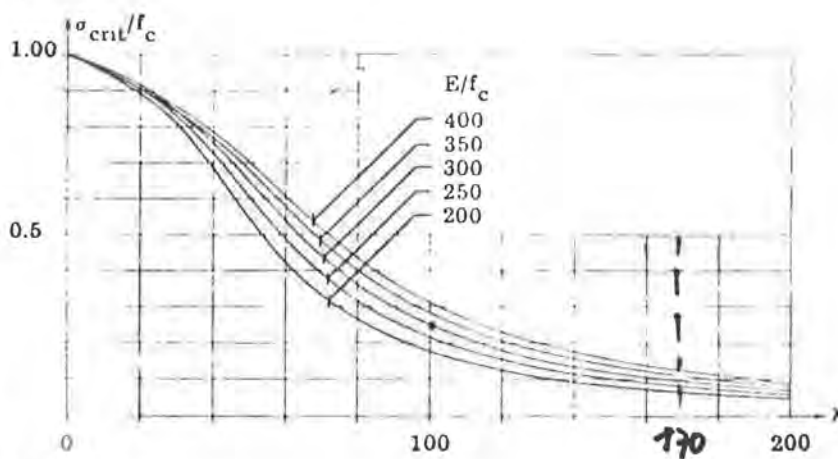

Fig. 5.1.1.7 a

CONSEIL INTERNATIONAL DU BÂTIMENT \* INTERNATIONAL COALITION FOR BUILDING RESEARCH STUDIES

CONSEIL INTERNATIONAL DU BÂTIMENT \* INTERNATIONAL COUNCIL FOR BUILDING RESEARCH STUDIES AND DOCUMENTATION

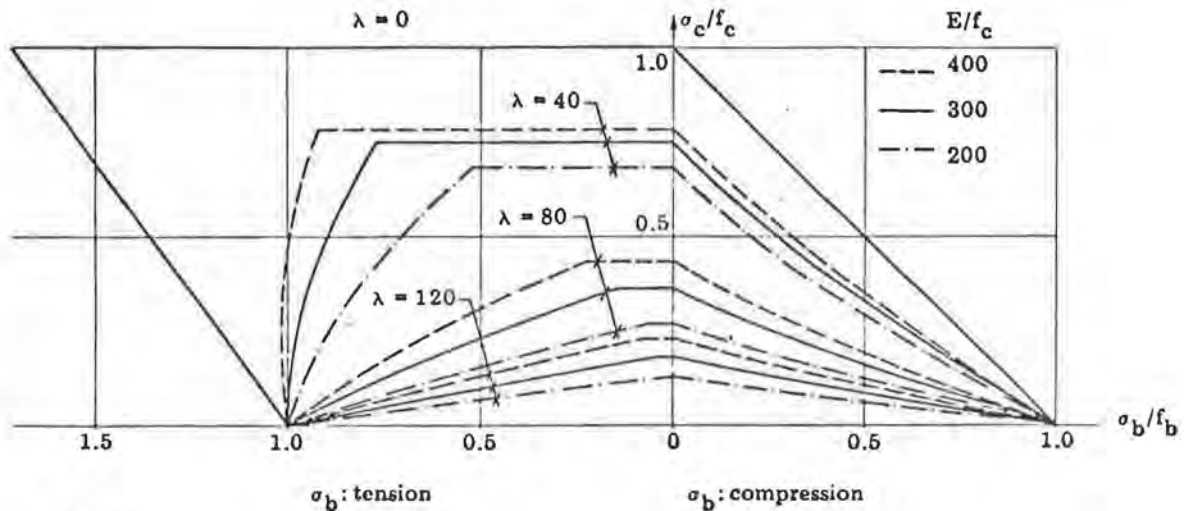

Fig. 5.1.1.7 b

5.1.2 Glued laminated timber

5.1.2.0 General

Glulam can be designed as solid timber, the strength parameters, however, should be taken from section 4.1.3.

If a cross-section is composed of several timber grades it can be assumed homogeneous with properties corresponding to those of the lowest grade in the outer sixth on either side.

5.1.2.1 - 5.1.2.3

(void)

5.1.2.4 Shear

The effect of notches in the bottom side is stronger than for solid timber, and notches should be avoided until further information is available.

5.1.2.5 - 5.1.2.7

(void)

5.1.2.8 Curved members

a. Strength reduction for axial stresses

The ratio between the radius of curvature,  $r$ , and the lamella thickness,  $t$ , should be greater than 100.

For  $r/t < 250$  the strength corresponding to axial stresses of the curved portion should be reduced by multiplication by the factor  $k_{curv}$  given in fig. 5.1.2.8 a.

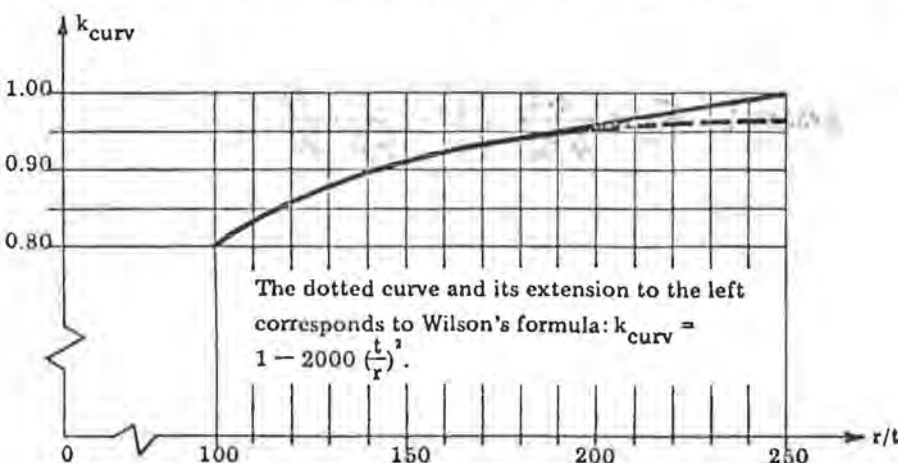

Fig. 5.1.2.8 a

*b. Distribution of bending stresses*

In heavily curved beams (i.e. the ratio between minimum mean-radius of curvature,  $r_m$ , and depth,  $h$ , less than 10) the influence of the curvature on the distribution of axial stresses from bending moments should be allowed for.

: In beams with rectangular cross-section the bending stresses in the innermost fibre  $\sigma_{bi}$  and the outermost fibre  $\sigma_{bo}$  can be calculated as

$$\sigma_{bi} = k_i \frac{6M}{bh^2} \tag{5.1.2.8 a}$$

$$\sigma_{bo} = k_o \frac{6M}{bh^2} \tag{5.1.2.8 b}$$

: where the modification factors  $k_i$  and  $k_o$  are given in fig. 5.1.2.8 b.

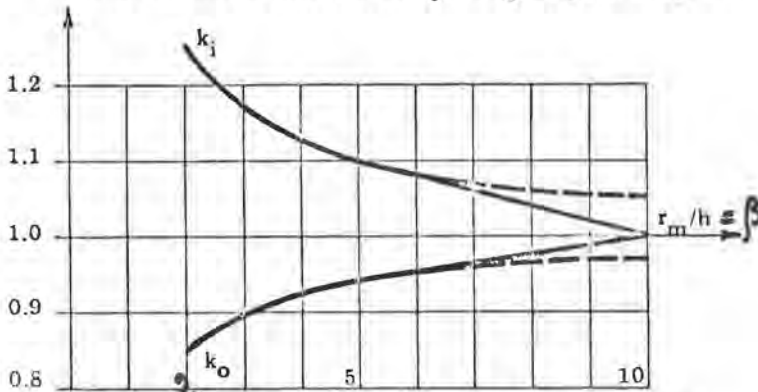

The dotted curves and their extensions to the left correspond to

$$k_i = 1 + 0.5 h/r_m \text{ and } k_o = 1 - 0.3 h/r_m$$

Fig. 5.1.2.8 b

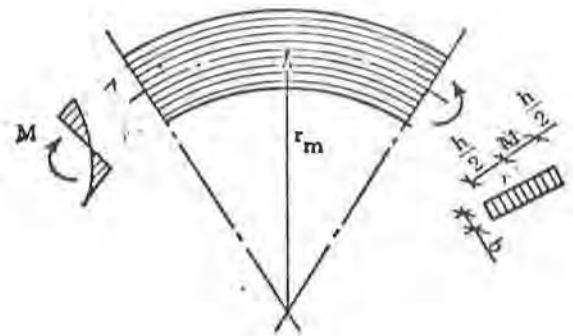

*c. Stresses perpendicular to the grain*

In curved beams where the bending moments tend to decrease curvature (increase the radius) it must be verified that the tensile stresses perpendicular to the grain satisfy the following condition:

$$\sigma_{t\perp} \leq f_{t\perp} \tag{5.1.2.8 c}$$

When the bending moments tend to increase curvature (decrease the radius) it must be verified that the compressive stresses perpendicular to the grain satisfy the following condition:

$$\sigma_{c\perp} \leq f_{c\perp} \tag{5.1.2.8 d}$$

: For beams with constant depth in the curved portion the maximum stresses may be calculated as

$$\sigma_{\perp} = 1.5 \frac{M}{r_m bh} \quad \text{besser: } \sigma_{\perp} = \frac{1.5}{4 r_m} \frac{M}{W} = \frac{1}{4\beta} \cdot \frac{M}{W} \tag{5.1.2.8 e}$$

: see fig. 5.1.2.8 b for notations.

: For beams with varying depth reference is made to section 5.1.2.9.

5.1.2.9 Cambered beams, straight or pitched

The influence of the cross-sectional variation should be taken into account. Especially it should be ensured that the tensile stresses perpendicular to grain do not exceed the design value.

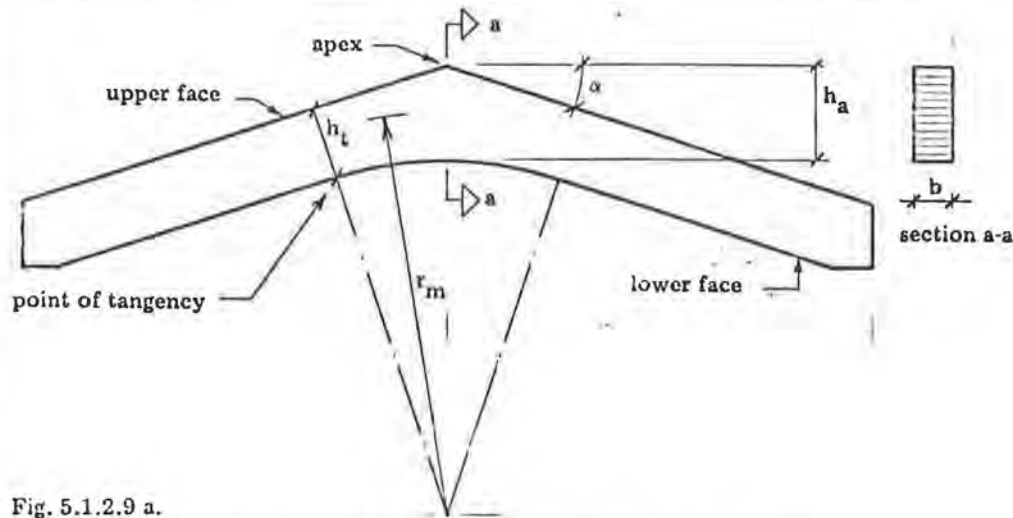

Fig. 5.1.2.9 a.

- : For softwood the following calculation method can be used:
- : The radial stress induced by bending in a pitched cambered beam of rectangular cross-section (see fig. 5.1.2.9 a)
- : is maximum near the mid-depth of the apex (ridge), and shall be calculated from either formula (5.1.2.9 a) or
- : (5.1.2.9 b):

$$\sigma_{tl} = \beta_a \left( \frac{6M_a}{bh_a^2} \right), \text{ or} \tag{5.1.2.9 a}$$

$$\sigma_{tl} = \frac{3M_a}{2r_m bh_a}, \text{ whichever is the larger,} \tag{5.1.2.9 b}$$

where

- $\sigma_{tl}$  = actual unit radial stress perpendicular to grain,
- $h_a$  = gross depth of cross-section at apex,
- $r_m$  = radius of curvature at mid-depth of member at apex,
- $b$  = breadth of cross-section,
- $M_a$  = bending moment at apex,
- $\beta_a$  = stress factor,

$$\beta_a = k_1 + k_2 \left( \frac{h_a}{r_m} \right) + k_3 \left( \frac{h_a}{r_m} \right)^2 \tag{5.1.2.9 c}$$

where  $k_1, k_2, k_3$  = constants, given in table 5.1.2.9 depending on the slope  $\alpha$  of the upper face.

Table 5.1.2.9. Values of constants for determination of radial stress in pitched cambered beams

Slope of upper surface of beam $\alpha$	Value of constant		
	$k_1$	$k_2$	$k_3$
2°5	0.0079	0.1747	0.1284
5°	0.0174	0.1251	0.1939
7°5	0.0279	0.0937	0.2162
10°	0.0391	0.0754	0.2119
15°	0.0629	0.0619	0.1722
20°	0.0893	0.0608	0.1393
25°	0.1214	0.0605	0.1238
30°	0.1649	0.0603	0.1115

Note: Values of  $\beta_a$  for slopes given in table 5.1.2.9 are shown graphically to  $\sigma_{tl}$  in fig. 5.1.2.9 b.

The radial stress at the points of tangency on either side of the apex (ridge) shall be calculated by formula (5.1.2.9 d):

$$\sigma_{lr} = \frac{3M_t}{2r_m b h_t} \tag{5.1.2.9 d}$$

where

$M_t$  = bending moment at point of tangency

$h_t$  = depth of beam at point of tangency.

The bending stress at the apex (ridge) in a pitched cambered beam of rectangular cross-section is maximum at the soffit and shall be calculated by the formula

$$\sigma_b = (1.0 + 2.7 \tan \alpha) \frac{6M_a}{b h_a^2} \tag{5.1.2.9 e}$$

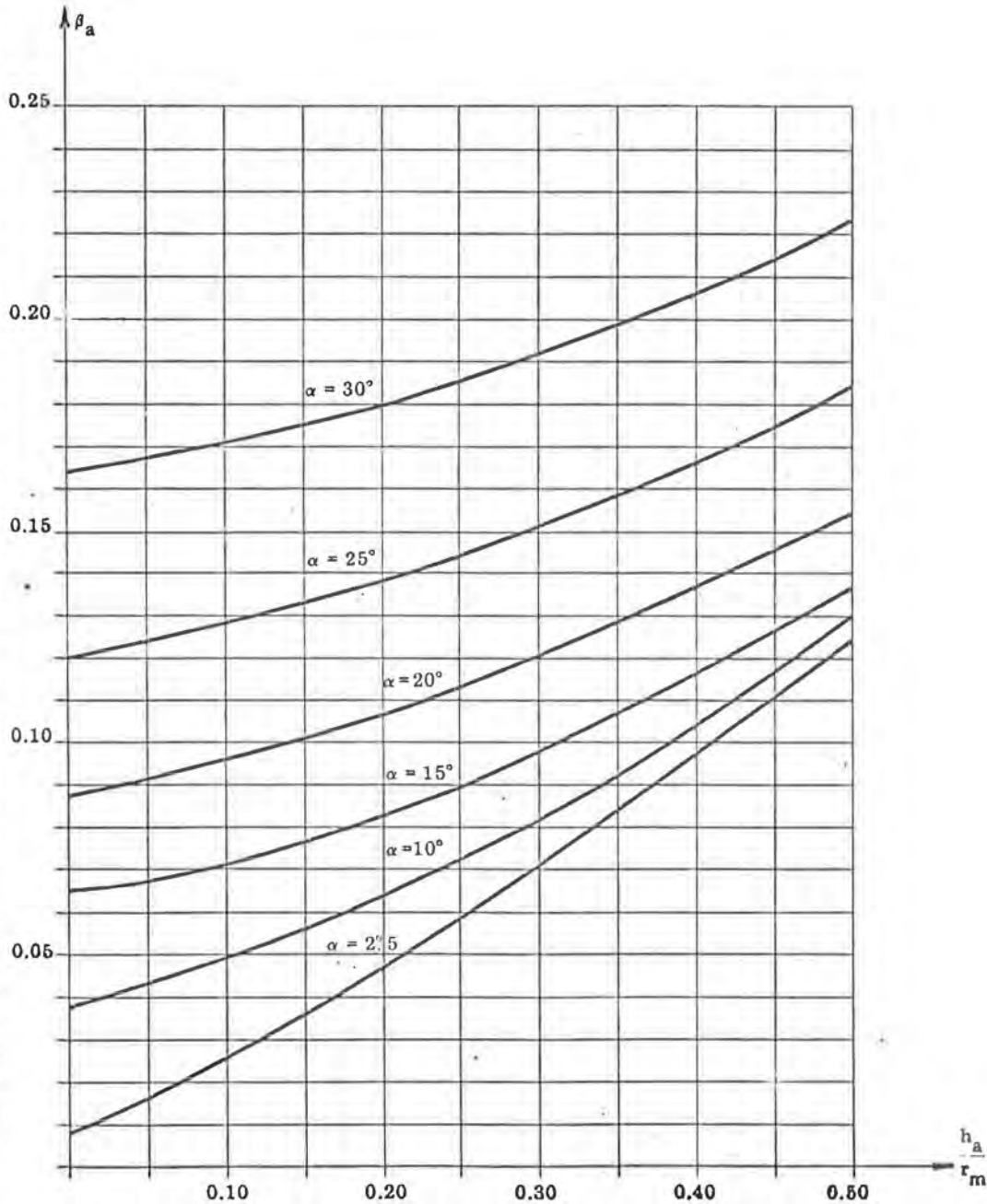

For notations reference is made to fig. 5.1.2.9 a.

Fig. 5.1.2.9 b

- : where  $\alpha$  is the slope of upper surface of beam, degrees from horizontal.
- : The bending stress at points of tangency on either side of the apex (ridge) in a pitched cambered beam of rectangular cross-section shall be calculated by the formula

$$\sigma_b = \frac{6M_t}{bh_t^2} \quad (5.1.2.9 f)$$

- : For hardwood a separate analysis of the stress field in a vertical section through the apex should be made.
- : In calculation of stresses at the point of tangency the formulas (5.1.2.9 d) and (5.1.2.9 f) may be used.

In deflection calculation contributions from the shear force deformations should be taken into account.

6. DESIGN OF COMPONENTS

6.1 Glued Components

6.1.1 Beams

6.1.1.1 Laminated beams

A laminated beam is considered as a basic element, and reference is made to section 5.1.2.

6.1.1.2 Thin-webbed beams

The stresses in thin-webbed beams may be calculated under the assumption of a linear variation of strain over the depth. In principle the stresses must satisfy the conditions given in section 5.1.

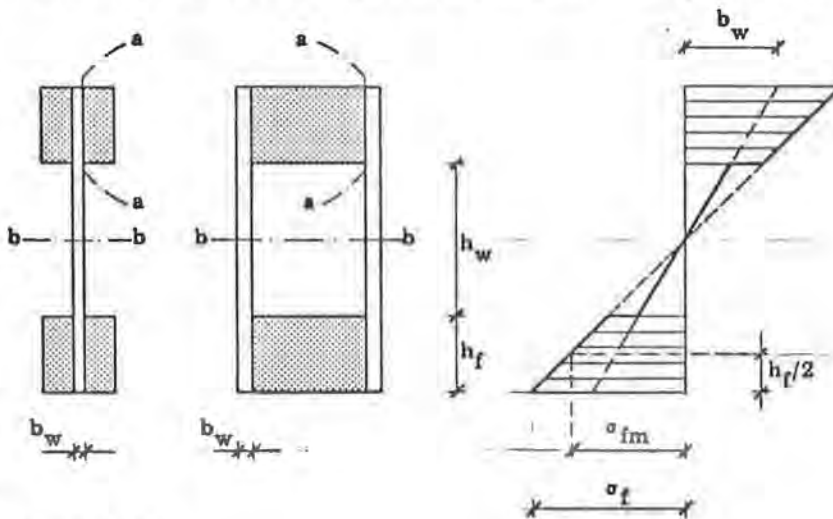

Fig. 6.1.1.2 a

For sections shown in fig. 6.1.1.2 a it must be shown that

$$\frac{|\sigma_{fm}|}{f} + \frac{|\sigma_f - \sigma_{fm}|}{f_b} < 1 \tag{6.1.1.2 a}$$

where \$f\$ is the strength in compression or tension depending on the sign of the stresses.

With regard to the shear stresses the shearing force may be assumed uniformly distributed over the entire width of the sections a-a and b-b, as shown in fig. 6.1.1.2 a.

It must be shown that the webs are sufficiently restrained to prevent buckling. If the webs are made from structural plywood, structural particle board or fibre board a buckling investigation is not necessary, if the free depth, \$h\_w\$, of the webs is less than \$2h\_{max}\$, where \$h\_{max}\$ is given in table 6.1.1.2, and the shear force \$V\$ satisfies the conditions given in formula (6.1.1.2 b).

Table 6.1.1.2

Web	\$h_{max}\$
Plywood with \$\varphi < 0.5\$	\$(20 + 50 \varphi)b_w\$
Plywood with \$\varphi \ge 0.5\$	\$45 b_w\$
Particle or fibre board	\$35 b_w\$

\$\varphi\$ is the ratio between the bending stiffness of a section with the width \$l\$ cut perpendicularly to the beam axis and the bending stiffness of a corresponding section cut parallelly to the longitudinal direction of the beam

**APPENDIX 1. Load-bearing curves for columns loaded with a central axial force**

Load-bearing curves for different values of  $E/f_c$  and  $f_c/f_b$  are given in fig. A 1.1. The following values for  $k_1$  and  $k_2$  are used:  $k_1 = 0,1$  and  $k_2 = 0,005$ .

$\sigma_{crit}$  is the value of  $\sigma_c$  corresponding to the equality sign in eq. (2) with  $\sigma_{bc} = 0$ .

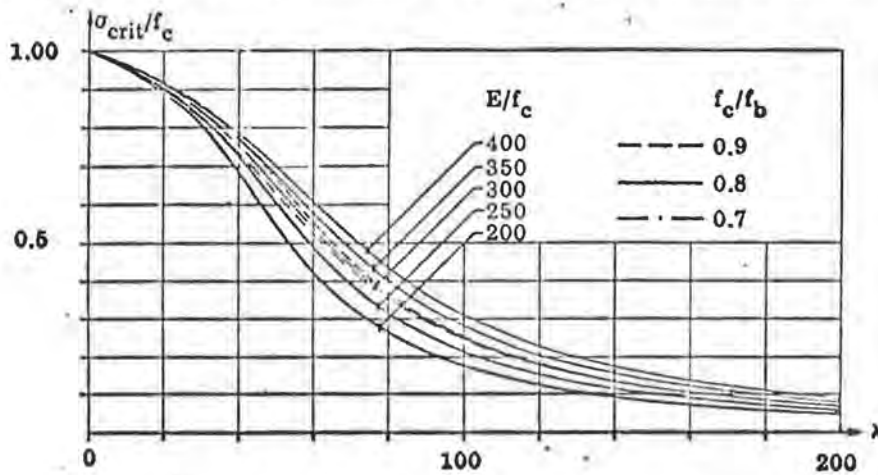

Figure A 1.1

APPENDIX 2. Load-bearing curves for columns loaded with a central axial force and a lateral load

Load-bearing curves for columns loaded with a central axial force and a lateral load. The diagram gives related values of  $\sigma_b/f_b$  and  $\sigma_c/f_c$  corresponding to the equality sign in eq. (2) or (3).

In the diagram  $f_c/f_b = 0.8$ ,  $k_1 = 0$  and  $k_2 = 0.005$  have been assumed.

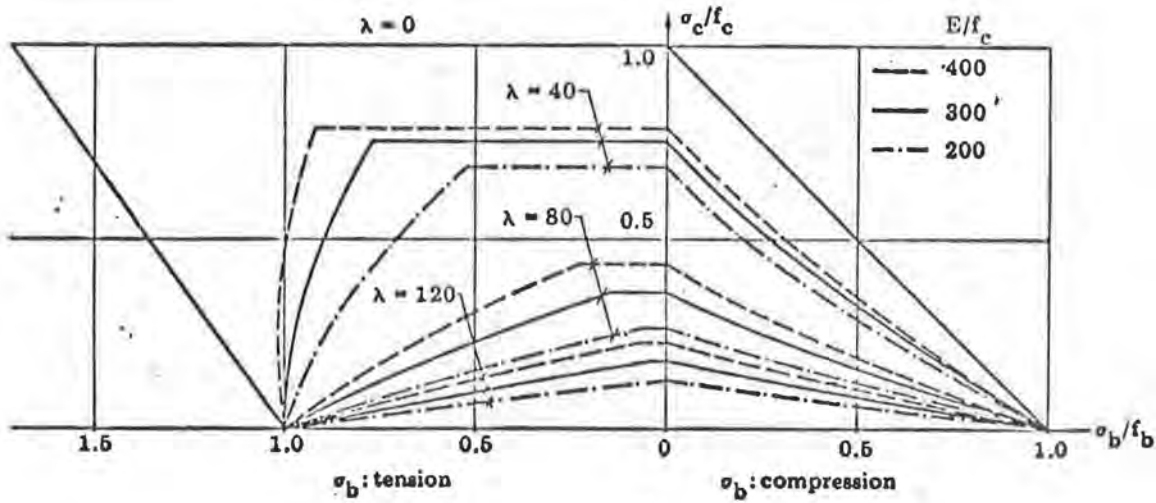

Figure A 2.1

No.  <b>02</b>	Subject: <b>MECHANICALLY JOINTED BEAMS AND COLUMNS WITH I-, T- OR BOX CROSS-SECTIONS</b>	Draft No. <b>1</b>	Date: <b>76.04.20</b>
----------------------	---	-----------------------	--------------------------

### 1. SCOPE

Beams or columns with cross-sections as shown in fig. 1 are dealt with. The individual members are connected to each other by nails, bolts with toothed metal plate connectors or similar non-rigid fasteners.

A method is given to determine stresses, deflections and load on the fasteners of beams and the load-carrying capacity of columns, including the necessary requirements to the fasteners.

### 2. NOTATIONS

Reference is made to fig. 1. In all cases the Z-axis is a symmetry axis. For cross-sections of type 1 the Y-axis is a gravity axis, while for type 2 and 3 it is a symmetry axis.

For beams bending about the Y-axis is assumed.

Type No.	Cross-section	A <sub>r</sub>	Stress distribution
1		$\frac{A_f A_w}{A_f + A_w}$	
2		$A_f$	
3			

Figure 1

It is assumed that the web is stiffened at the supports and under concentrated loads. The stiffeners should be fastened to the web and tightly fit between the top and bottom flanges. The cross-section of the stiffeners are chosen so that the whole force can be transferred between flange and stiffener.

$$v < \begin{cases} f_v b_w (h_w + h_f) & \text{for } h_w \leq h_{\max} \\ f_v b_w h_{\max} (1 + \frac{h_f}{h_w}) & \text{for } h_{\max} < h_w \leq 2h_{\max} \end{cases} \quad (6.1.1.2 \text{ b})$$

In other cases a special investigation must be carried out.

- : This can for example be carried out according to the theory of elasticity for perfectly plane plates which are
- : assumed simply supported along flanges and at web stiffeners.
- : These assumptions lead to the following expression for the critical axial stress and the critical shear stress

$$\sigma_{\text{crit}} = \alpha \frac{\pi^2 \sqrt{(EI)_x (EI)_z}}{ta^2} \quad (6.1.1.2 \text{ c})$$

$$\tau_{\text{crit}} = \alpha \frac{\pi^2 \sqrt{(EI)_z (EI)_x^3}}{ta^2} \quad (6.1.1.2 \text{ d})$$

- : where  $\alpha$  is a factor which is dependent upon the stress distribution and the parameters  $\beta_1$  and  $\beta_2$ , cf. fig.
- : 6.1.1.2 c, where  $\alpha$  is given for the most common cases.

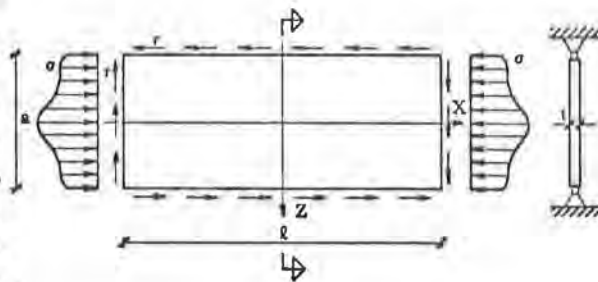

Fig. 6.1.1.2 b

The following notations are used (reference is also made to fig. 6.1.1.2 b):

$(EI)_x$  is the bending stiffness of the panel per unit length in bending about the X-axis. For a homogeneous orthotropic panel with the main directions X and Z,  $(EI)_x = \frac{1}{12} Et^3 / (1 - \nu_{xz} \nu_{zx})$ , where  $\nu_{xz}$  and  $\nu_{zx}$  are Poisson's ratios. For wood-based panels  $\nu_{xz} \nu_{zx} \sim 0$  can be assumed.

$(EI)_z$   $(EI)_x$ , but in bending about the Z-axis.

$(GI)_v$  is the torsional stiffness per unit length of the panel. For a homogeneous orthotropic panel,  $(GI)_v = Gt^3 / 3 + [\nu_{xz}(EI)_x + \nu_{zx}(EI)_z] \sim Gt^3 / 3$ .

$\beta_1 = \frac{2}{a} \sqrt{(EI)_x / (EI)_z}$ . For an isotropic panel,  $\beta_1 = 2/a$ .

$\beta_2 = 0.5 (GI)_v / \sqrt{(EI)_x (EI)_z}$ . For an isotropic panel,  $\beta_2 = 2G/E$ .

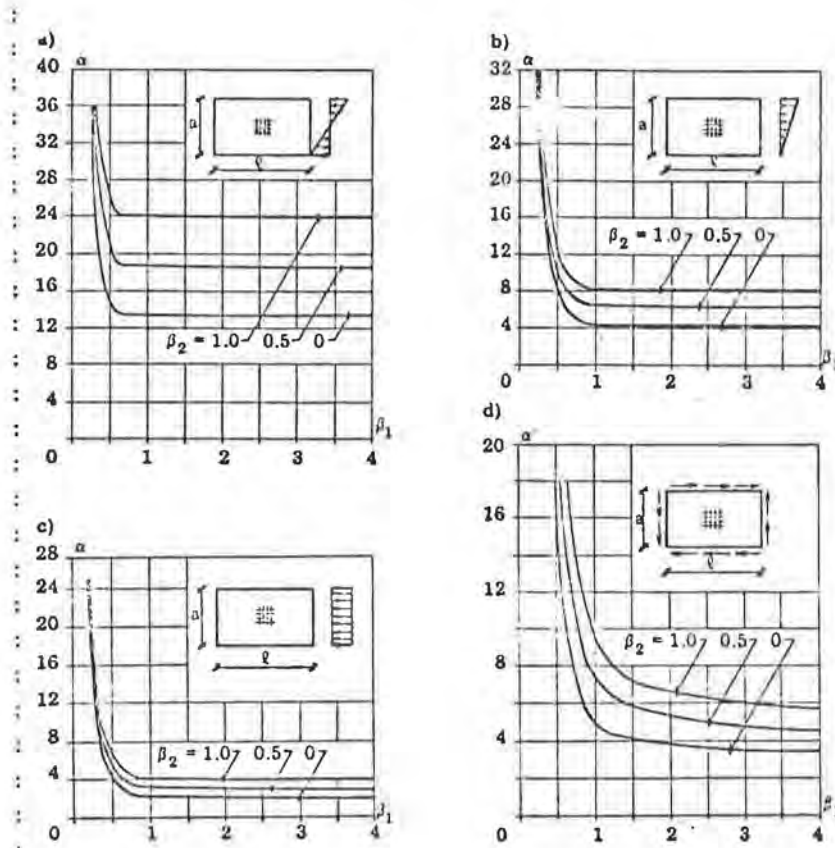

Fig. 6.1.1.2 c

The lateral stability should be proved satisfactory.

- : For box beams this may on the safe side be proved as for solid beams, cf. section 5.1.1.3. For I-beams it is
- : on the safe side to consider the compression flange as a column with a free length corresponding to the outer
- : restraints.

In deflection calculations the contributions from the shearing stresses in the webs should be taken into account.

6.1.1.3 Thin-flanged beams (stiffened plates)

The stresses may be calculated under the assumption of a linear variation of strain over the depth and the stresses must in principle satisfy the conditions given in section 5.1

- : The influence of the stresses not being uniformly distributed over the flange width should be taken into con-
- : sideration.

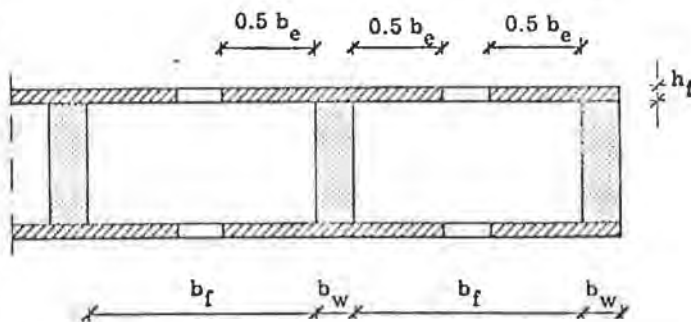

Fig. 6.1.1.3 a

- : Unless otherwise proved more correct the effective width can be assumed equal to the hatched area in fig. 6.1.1.3 a, where  $b_e = \frac{2}{3} \ell$  for plywood and  $b_e = \ell/3$  for fibre boards and particle boards.  $\ell$  is the span, for continuous beams, however,  $\ell$  is the distance between the points with zero moment.

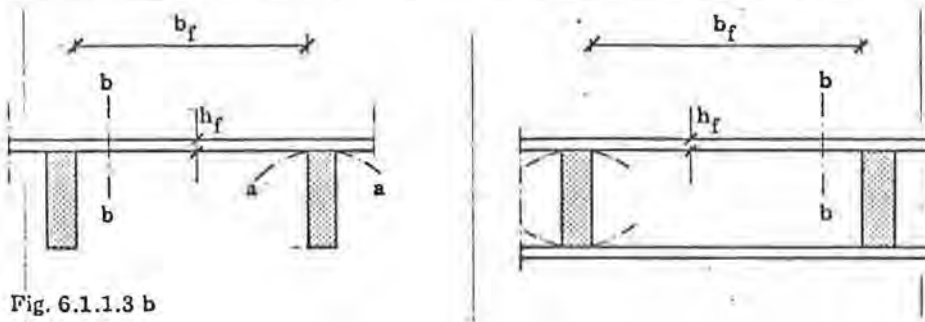

Fig. 6.1.1.3 b

With regard to shear stresses in the types of section (a-a and b-b) shown in fig. 6.1.1.3 b the shear force may be assumed uniformly distributed over the entire width.

It must be shown that the webs are sufficiently restrained to prevent buckling. If the webs are made from structural plywood, structural particle board or fibre board a buckling investigation is not necessary if the free distance  $b_f$  between the flanges is less than  $2b_{max}$ , where  $b_{max}$  is given in table 6.1.1.3, and the axial stresses in the flanges satisfy the conditions given in formula (6.1.1.3 a).

Table 6.1.1.3

Flange	$b_{max}$
Plywood with fibre direction in extreme plies	
parallel to the web	$25 h_f$
perpendicular to the web	$20 h_f$
Particle board or fibre board	$30 h_f$

$$\sigma \leq \begin{cases} f_c & \text{for } b_f \leq b_{max} \\ \frac{b_{max}}{b} f_c & \text{for } b_{max} < b_f < 2b_{max} \end{cases} \quad (6.1.1.3 a)$$

In other cases a buckling investigation must be made.

- : This may be carried out as shown in section 6.1.1.2.

## 6.1.2 Columns

### 6.1.2.1 Laminated columns

As for beams, cf. section 6.1.1.1.

### 6.1.2.2 I- and box columns

The relevant parts of 6.1.1.2 and 6.1.1.3 apply.

### 6.1.2.3 VOID

### 6.1.2.4 Spaced columns

What is stated for solid columns apply (cf. section 5.1.1.7), but furthermore, the deformation due to shear and bending in packs or battens and shafts should be taken into consideration.

- : A design method is given in CIB-Timber Standard 03.

#### 6.1.2.5 *Lattice columns*

What is stated for solid columns apply (cf. section 5.1.1.7), but furthermore the deformations due to extension of the lattice and bending, if any, of the flanges should be taken into consideration.

: A design method is given in CIB-Timber Standard 04.

## 6.2 Mechanically jointed components

### 6.2.0 General

If the cross-section of a structural member is composed of several parts connected by mechanical fasteners consideration must be taken to the influence of the slip occurring in the fasteners.

Besides, the same as stated in sections 5 and 6.1 is valid.

The calculation is allowed to be carried out according to the theory of elasticity. For the slip modulus  $k$  the values given in table 6.2.0 may be applied for European structural softwoods in the design of beams.

Table 6.2.0

Fastener	Slip modulus (N/mm)
Round nails with $d < 6$ mm	$0.02 E d^{\star}$
Round nails with $d > 6$ mm	$0.12 E^{\star}$
Bolts with pressed-in connectors	$1.5 E$

$E$  is the modulus of elasticity in  $N/mm^2$ ,  $d$  is the diameter in mm for round nails or the side length for square nails.

$\star$  For square nails 15% higher values are allowed.

### 6.2.1 Beams

: A design method for a number of cross-sections is given in CIB-Timber Standard 02.

### 6.2.2 Columns

: A design method for a number of cross-sections is given in CIB-Timber Standards 02, 03, and 04.

7. DESIGN OF SPECIAL STRUCTURES

7.1 Arches, portals and frames

In the determination of the stress resultants the influence of deviations between intended and real geometry and the deformations should be taken into consideration.

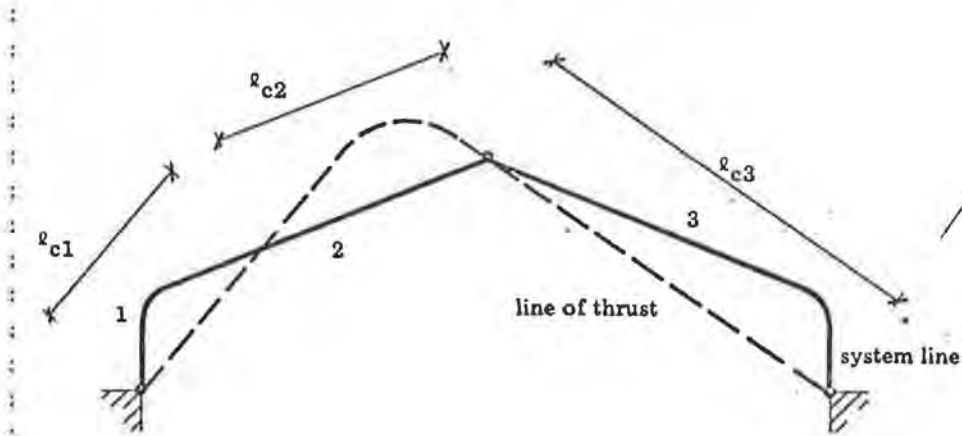

Fig. 7.1 a

For ordinary frames where there is considerable deviation between the system line and the acting-line for the resultant forces (line of thrust) this can in principle be carried out in conformity with section 5.1.1.7 with the free column length,  $l_c$ , calculated as the distance between the points with zero moment lying on either side of the section for the load combination in question, cf. fig. 7.1 a.

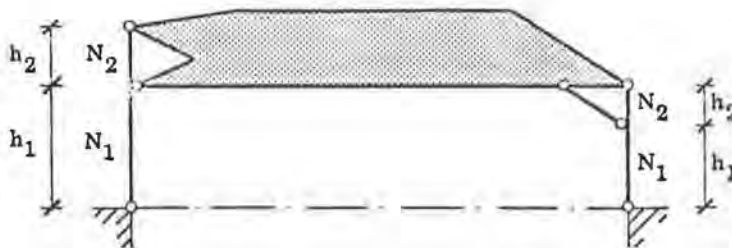

Fig. 7.1 b

For a frame consisting of a stiff beam and vertical legs with inclined stiffeners, if any, cf. fig. 7.1 b, for  $h_1 > h_2$ ,  $l_c = 2h_1 + 0.7 h_2$  is assumed. The largest axial force ( $N_1$  or  $N_2$ ) occurring in the column in question is used.

## 7.2 Trusses

Trusses can be calculated as a frame structure where the influence of initial curvature of the elements, eccentricities, deformations of elements and slip and rotation in the joints are taken into consideration in the determination of the stress resultants.

As an alternative a simplified calculation after the following guidelines is allowed: The axial forces are calculated assuming hinges in all nodal points, and the moments in continuous members, if any, are assumed to lie between 80% and 100% of the simple moments (corresponding to hinges in both ends) dependent upon the degree of end-fixing and the support conditions. For non-continuous members the moments are assumed equal to the simple moments. The free column length is assumed between 85% and 100% of the theoretical nodal point distance dependent upon continuity and degree of restraint.

## 8 CONSTRUCTION

### 8.0 General

All timber structures should be so constructed that the completed structure conforms with principles and practical considerations on which it was designed. Workmanship in fabrication, preparation, and installation of materials shall conform throughout to accepted good practice.

## 8.1 Materials

Unless specifically designed for the purpose, timber components and structural elements should not be exposed to high humidity, and all materials and assemblies should be protected against exposure to the weather, wetting, damage, decay and insect attack.

Timber should be appropriately protected against changes in humidity and damage in such a way that the requirements of the code are satisfied throughout the life of the timber. Timber which is damaged locally, crushed or otherwise overloaded, e.g. in transport, should not be used.

The moisture content of the timber used should be adjusted to the climatic influences to which the structure will be exposed, and the conditions in the completed structure should be especially considered.

## 8.2 Machining

All timber should be sawn, planed, drilled or otherwise machined to the correct shape and size in accordance with the detailed drawings and specifications supplied.

The quality of the surface, as finished, should be appropriate to the position and use of the timber, and in accordance with the instructions given in the specifications.

Surfaces at any joint in an assembly should be such that the parts may be brought into contact over the whole area of the joint before connectors are inserted or any pressure or restraint from the fastenings is applied. These surfaces should have a good sawn or planed finish.

Bearing surfaces of notches and other cuttings should be true and smooth and in appropriate relation to the other surfaces of the piece.

Notches other than at the ends of beams should be U-shaped and formed by parallel cuts to previously drilled holes. The diameter of the hole should be equal to the width of the required notch.

The cutting of timber after preservative treatment should be avoided. When, however, it is unavoidable, and exposure of untreated timber results, a liberal application of preservative should be made to the cut surfaces.

### 8.3 Joints

The individual structural members should be assembled so that unintentional stresses do not occur. Members which are warped, split or badly fitting at the joints should be replaced.

Care should be taken to avoid placing nails, screws, and bolts, etc. in any end split.

Besides, for the individual fasteners reference is made to the construction rules given in chapter 4.3.

#### 8.4 Assembly

Assembly of units should be done on a level bed and in such a way as to avoid damage to any of the members and so that the finished structural units conform to detailed drawings and specification supplied.

When assembly is to be performed on the site, one set of component parts should be fitted together and dismantled prior to despatch to the site, in order to ensure that the assembled structural units conform to the detailed drawings and specifications. Twisted or damaged members should be replaced before erection on the site.

Before proceeding with bulk production, a complete assembly of one of each framed truss or other structural unit should be checked to prove the accuracy of the templates, etc. A similar check should be carried out from time to time to control the wear and tear on templates and gauges.

### 8.5 Transportation

All materials and assemblies should be protected from the weather, and suitable measures should be taken to protect the surfaces during hoisting, etc.

The over-stressing of members during handling should be avoided. In the case of framed arches, portal frames, etc., special care should be taken to avoid distortion in hoisting from the horizontal to the vertical position. Where lifting points or methods of lifting are not indicated on the design, guidance should be sought from the designer.

### 8.6 Erection

The over-stressing of members during erection should be avoided. In the case of framed arches, portal frames, etc., special care should be taken to avoid distortion in hoisting from a horizontal to the vertical position. Where lifting points or methods of lifting are not indicated, guidance should be sought from the designer.

On completion of erection all joints should be inspected and care taken to see that all bolts are tightened without crushing the wood under the washers.

No.  <b>01</b>	Subject: <b>DESIGN OF SOLID TIMBER COLUMNS</b>	Draft No.      Date: 2                      76.04.20
----------------------	---	---

### 1. SCOPE

A simply supported column loaded by a central axial force and a lateral load resulting in deflection along one of the main axes of the cross-section (in the figure the z-axis) is dealt with. Expressions for the acceptable load combinations are stated.

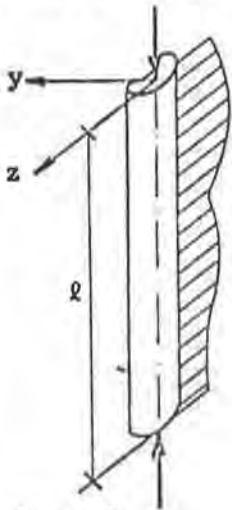

Figure 1

### 2. NOTATIONS

See figs. 1 and 2.

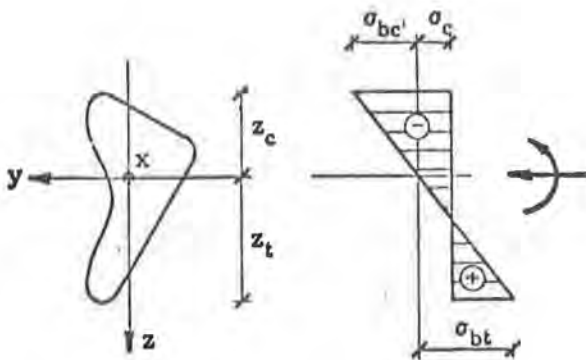

Figure 2. y and z are the main axes of the cross-section.

A	Cross-sectional area
E	Modulus of elasticity
$I = I_y$	Moment of inertia about the y-axis
$W_c = I_y / z_c$	Section modulus for the outermost fibre in compression
e	Eccentricity
$f_b$	Strength in bending
$f_c$	Strength in compression
$i = \sqrt{I/A}$	Radius of gyration
$k_1, k_2$	Constants, see section 3
l	Free length
$k_E = \frac{\pi^2 E}{\lambda^2 f_c}$	Constant
$z_c$	Distance from centroid to outermost fibre in compression
$\lambda = l/i$	Slenderness ratio
$\sigma_b$	Bending stress
$\sigma_{bc}, \sigma_{bt}$	Bending stresses (numerical values) in the outermost fibres in compression or tension, respectively, due to the lateral load and calculated according to the theory of elasticity
$\sigma_c$	Compressive stress (numerical value)

### 3. ASSUMPTIONS

The column is assumed to have initial curvature corresponding to the axial force in the centre of the column having an eccentricity e, expressed as

$$e = (k_1 + k_2 \lambda) \frac{I}{Az_c} \tag{1}$$

where  $I/(Az_c)$  is the core radius corresponding to the compressive side.

The bending moment is assumed to vary sinusoidally from zero at the ends to a maximum value at the middle, the error, however, by using the formulas also for other moment distributions (e. g. constant moment corresponding to eccentric load) is small.

If  $I_y$  is the greatest moment of inertia of the cross-section, the column is assumed to be secured against deflection in the y-direction so that the failure will occur by deflection along the z-axis and not by lateral and torsional deflection.

### 4. DESIGN CRITERIONS

The permissible combinations of stresses from the axial force and the moment are given by the following expressions:

Compressive side:

$$2(1 - k_1 \frac{f_c}{f_b}) \frac{\sigma_c}{f_c} < 1 + (1 + k_2 \lambda \frac{f_c}{f_b}) k_E - \sqrt{(1 + (1 + k_2 \lambda \frac{f_c}{f_b}) k_E)^2 - 4(1 - \frac{\sigma_{bc}}{f_b})(1 - k_1 \frac{f_c}{f_b}) k_E} \tag{2}$$

Tensile side:

$$\frac{\sigma_{bL}}{f_b} < \left(1 + \frac{\sigma_c}{f_b}\right) \left(1 - \frac{\sigma_c}{k_E f_c}\right) - (k_1 + k_2 \lambda) \frac{\sigma_c}{f_b} \quad (3)$$

## 5. LIMITATION OF $\lambda$

For primary and secondary structural members  $\lambda$  should not exceed 170 and 200, respectively.

## 6. EXTENSION OF THE AREA OF APPLICATION

The stated method of dimensioning may also be applied (with approximation) to other kinds of support, if their influence on the critical length is allowed for in the usual manner.

## 7. REFERENCES

The background for the method are given in the following reports prepared for CIB-W18:

The Design of Solid Timber Columns. Aalborg University Centre, Pure and Applied Mechanics, Report R7406, 1974.

Tests with Centrally Loaded Timber Columns. Report R7405, 1974 - as above.

No.

02

Subject:

MECHANICALLY JOINTED BEAMS AND COLUMNS WITH I-, T- OR BOX CROSS-SECTIONS

Draft No.

1

Date:

76.04.20

CONSEIL INTERNATIONAL DU BÂTIMENT \* INTERNATIONAL COUNCIL FOR BUILDING RESEARCH STUDIES AND DOCUMENTATION

### 1. SCOPE

Beams or columns with cross-sections as shown in fig. 1 are dealt with. The individual members are connected to each other by nails, bolts with toothed metal plate connectors or similar non-rigid fasteners.

A method is given to determine stresses, deflections and load on the fasteners of beams and the load-carrying capacity of columns, including the necessary requirements to the fasteners.

### 2. NOTATIONS

Reference is made to fig. 1. In all cases the Z-axis is a symmetry axis. For cross-sections of type 1 the Y-axis is a gravity axis, while for type 2 and 3 it is a symmetry axis.

For beams bending about the Y-axis is assumed.

Type No.	Cross-section	$A_T$	Stress distribution
1		$\frac{A_f A_w}{A_f + A_w}$	
2		$A_f$	
3			

Figure 1

5.2. Calculation of maximum shear stresses

For cross-sections of type 1 the maximum shear stresses occur where the stresses in the web are zero and can be calculated from

$$\max \tau = \frac{Qh_t^2}{2I_e} \tag{11}$$

For cross-sections of types 2 and 3 the maximum shear stresses occur in the middle of the web and can be calculated from

$$\max \tau = \frac{Q}{I_e b_w} \left( \gamma A_f \frac{h_f + h_w}{2} + \frac{1}{8} A_w h_w \right) \tag{12}$$

5.3. Calculation of load on fasteners

The load per fastener can be determined from

$$F = \gamma \frac{QS_f}{I_e} s \tag{13}$$

5.4. Deflections

The deflections from the moment are calculated as usual applying the effective moment of inertia  $I_e$ .

6. CONCENTRICALLY LOADED COLUMNS

6.1. Load-carrying capacity

The load-carrying capacity corresponding to deflection along the Z-axis can be determined as

$$P_{crit} = A_t f_{crit} \tag{14}$$

The ultimate stress,  $f_{crit}$ , is determined as for a corresponding cross-section with rigid joints between the cross-section members, but the effective slenderness ratio:

$$\lambda_e = l \sqrt{\frac{A_t}{I_e}} \tag{15}$$

is used.

For the T-cross-section and the I-cross-section, type 2, the load-carrying capacity for deflection in the Y-direction is found as the sum of the load-carrying capacity of the individual members, i.e. the stiffening effect that the members might have on each other is not taken into account.

6.2. Load on fasteners

The load on the fasteners can be calculated by eq. (13), assuming

$$Q = \left\{ \begin{array}{ll} \frac{P}{60} \frac{f_c}{f_{crit}} & \text{for } 60 \leq \lambda_e \\ \frac{\lambda_e}{60} \frac{P}{60} \frac{f_c}{f_{crit}} & \text{for } 30 \leq \lambda_e \leq 60 \\ \frac{P}{120} \frac{f_c}{f_{crit}} & \text{for } \lambda_e \leq 30 \end{array} \right\} \tag{16}$$

## 7. COMBINED LOADS

In cases where small moments resulting from e.g. own weight are acting apart from axial load, the usual interaction formulas can be used for the stresses determined above.

## 8. REFERENCES

K. Möhler, J. Ehlbeck, G. Hempel & P. Köster: Erläuterungen zu DIN 1052, Blatt 1 und 2 - Holzbauwerke - Ausgabe Oktober 1969 with further references.

The design of built-up timber columns. Aalborg University Centre, Pure and Applied Mechanics, Report R7406, 1974. (Paper prepared for CIB-W18).

No.

03

Subject:

SPACED COLUMNS WITH NAILED OR GLUED PACKS OR BATTENS

Draft No.

1

Date:

76.04.20

CONSEIL INTERNATIONAL DU BÂTIMENT \* INTERNATIONAL COUNCIL FOR BUILDING RESEARCH STUDIES AND DOCUMENTATION

### 1. SCOPE

Columns as shown in fig. 1 are dealt with, i.e. columns with two or in certain cases three or four identical shafts jointed with packs or battens. The joints may be either nailed or glued or bolted with toothed metal plate connectors. Expressions are given to determine an effective moment of inertia and thus an effective slenderness ratio, whereupon the critical column stress is determined as for a column of solid timber with the same slenderness ratio.

It is assumed that the construction rules given in section 3 are observed, and that the joints are designed for forces as stated in section 6.

Only concentrically loaded columns are dealt with.

### 2. NOTATIONS

Reference is made to fig. 1.

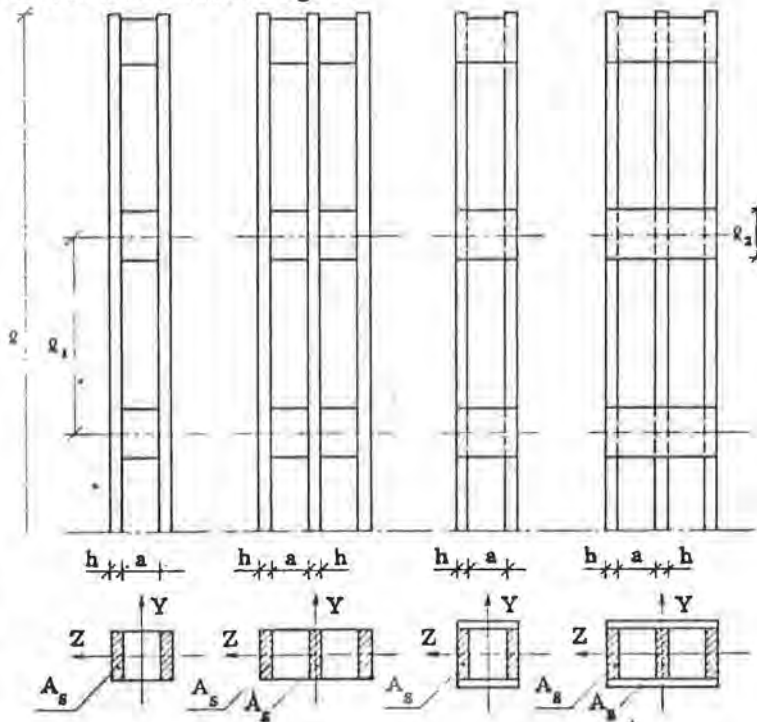

Fig. 1.

A	Area	
	$A_s$	Area of one shaft
	$A_t = nA_s$	Total area
I	Moment of inertia (second moment of area)	
	$I_s$	I for one shaft about own gravity axis
	$I_t$	Total moment of inertia about Y-axis
P	Column load	
	$P_{crit}$	Load-carrying capacity
Q	Shear force	

$T_0$	See fig. 3
$a$	Distance
	$a$ Free distance between shafts
	$a_1 = a + h$ See fig. 3
$l$	length
	$l$ Free length of column
	$l_1$ Distance between midpoints of packs or battens
	$l_2$ Length of packs or battens
$n$	Number of shafts
$\lambda$	Slenderness ratio
	$\lambda = l \sqrt{\frac{A_t}{I_t}}$ Slenderness ratio for a solid column with the same cross-section
	$\lambda_1 = l_1 \sqrt{\frac{A_s}{I_s}}$ Slenderness ratio for the shafts
	$\lambda_e$ Effective slenderness ratio
$\eta$	Factor, see table 2.

### 3. ASSUMPTIONS

- The cross-section is composed of 2, 3 or 4 identical shafts.
- The Y- and Z-axes are symmetry axes.
- The number of free fields are at least 3, i.e. the shafts are at least jointed in the ends and in the third points.
- The free distance between the shafts is not greater than 5 times the lamella thickness ( $a/h \leq 5$ ).
- The joints and packs and battens are designed for a shear force  $Q$  as stated in section 5.
- The length of the packs should satisfy the condition  $l_2/a \geq 1.5$ .
- For nailed joints there should in each section be at least 4 nails or 2 bolts with metal plate connectors. For nailed joints at the ends apply that there should be at least 4 nails in a row in the longitudinal direction of the column.
- Battens should be made of structural plywood and their length satisfy the condition  $l_2/a \geq 2$ .
- The columns are solely subjected to concentric axial loads.

### 4. LOAD-CARRYING CAPACITY

For deflection in the Y-direction the load-carrying capacity can be determined as the sum of the load-carrying capacity of the individual members.

For deflection in the Z-direction the load-carrying capacity are determined as

$$P_{\text{crit}} = A_t f_{\text{crit}} \quad (1)$$

The ultimate stress  $f_{\text{crit}}$  is determined as for solid columns, but the slenderness ratio

$$\lambda = l \sqrt{\frac{A_t}{I_t}} \quad (2)$$

is replaced by the effective slenderness ratio

$$\lambda_e = \sqrt{\lambda^2 + \eta \frac{n}{2} \lambda_1^2} \tag{3}$$

$\eta$  is given in table 2.

Table 2:  $\eta$

	Packs			Battens	
	glued	nailed	bolted*	glued	nailed
Long-term loading	1	4	3.5	2	6
Short-term loading	1	3	2.5	2	4.5

\* with toothed metal plates.

### 5. SHEAR FORCES

The load on the fasteners and battens or packs can be calculated as stated in fig. 3, assuming

$$Q = \begin{cases} \frac{P}{60} \frac{f_c}{f_{crit}} & \text{for } 60 \leq \lambda_e \\ \frac{\lambda_e}{60} \frac{P}{60} \frac{f_c}{f_{crit}} & \text{for } 30 \leq \lambda_e < 60 \\ \frac{P}{120} \frac{f_c}{f_{crit}} & \text{for } \lambda_e < 30 \end{cases}$$

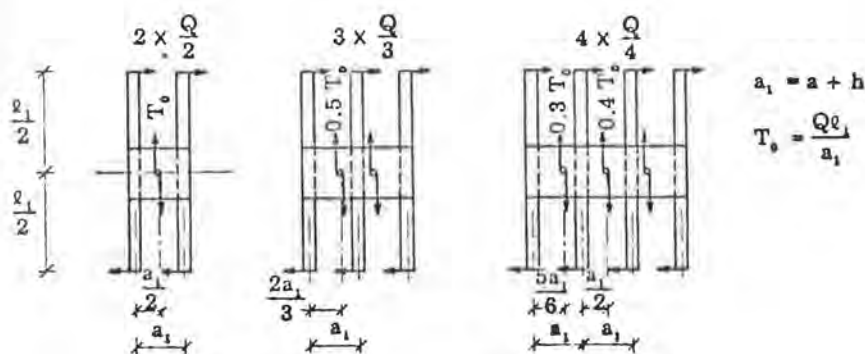

Fig. 2

### 6. REFERENCES

K. Möhler, J. Ehlbeck, G. Hempel & P. Köster: Erläuterungen zu DIN 1052, Blatt 1 und 2 - Holzbauwerke - Ausgabe Oktober 1969 with further references.

The design of built-up timber columns. Aalborg University Centre, Pure and Applied Mechanics, Report R7406, 1974. (Paper prepared for CIB-W18).

No. 04

Subject: LATTICE COLUMNS WITH GLUED OR NAILED JOINTS

Draft No. 1 Date: 76.04.20

CONSEIL INTERNATIONAL DU BÂTIMENT \* INTERNATIONAL COUNCIL FOR BUILDING RESEARCH STUDIES AND DOCUMENTATION

### 1. SCOPE

Lattice columns with N- or V-lattice and with glued or nailed joints are dealt with.

Expressions are given to determine an effective moment of inertia and thus an effective slenderness ratio whereupon the critical column stress is determined as for a column of solid timber with the same slenderness ratio.

It is assumed that the joints are designed for forces as stated in sections 3 and 5.

### 2. NOTATIONS

Reference is made to fig. 1.

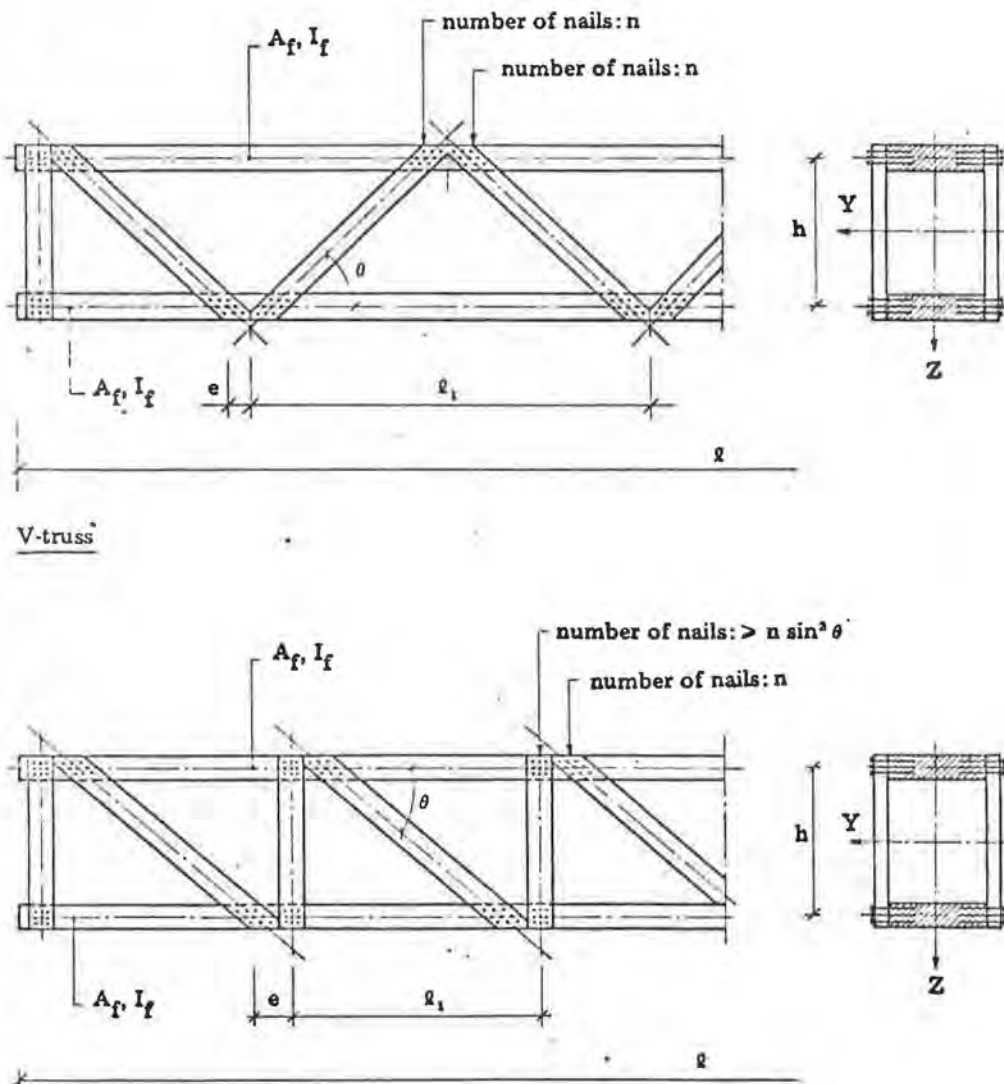

Fig. 1

- A Area
- $A_f$  Area of one flange
- I Moment of inertia (second moment of area)
- $I_f$  I for one flange about own axis
- $I_t$  Total value:  $I_t = 2I_f + \frac{1}{2} A_f h^2$
- P Axial load on column
- Q Shear force
- e Eccentricity
- f Strength
- $f_c$  Compression strength
- $f_{crit}$  Critical stress in columns
- h Depth of column (flange centre distance)
- $i_f$  Radius of gyration ( $= \sqrt{I_f/A_f}$ )
- k Slip modulus for one nail, i.e. the force per nail that will cause a slip of 1
- $\ell_1$  Joint distance
- n Number of nails per diagonal in a joint. If the diagonal consists of two or more pieces, n is the sum of nails, not the number of nails per shear face
- $\theta$  Angle between a flange and a diagonal
- $\lambda$  Slenderness ratio
- $\lambda_e$  Effective slenderness ratio
- $\lambda_f$  Slenderness ratio of a flange ( $\ell_1/i_f$ )
- $\mu$  Parameter, see section 4.

### 3. ASSUMPTIONS

The structure is assumed to be symmetric about the Y- and Z-axes of the cross-section. However, the lattice of the two sides are allowed to be staggered the length  $\ell_1/2$ .

There should be at least 3 fields, i.e.  $\ell >$  about  $3\ell_1$ .

The column should be designed for a shear force Q, as stated in section 5, i.e. the diagonals and joints should be designed for  $Q/\sin\theta$ .

In nailed structures at least 4 nails per shear should be used in each diagonal in each nodal point. At each end bracings should be used.

The slenderness ratio for the individual flange corresponding to the length  $\ell_1$  must not exceed 60, i.e.

$$\lambda_f \leq 60$$

Besides, it assumed that no local rupture is occurring in the flanges corresponding to the column length  $\lambda_1$ .

### 4. LOAD-CARRYING CAPACITY

The load-carrying capacity corresponding to deflection in the Y-direction is equal to the sum of the load-carrying capacity of the flanges for deflection in this direction.

For deflection in the Z-direction the load-carrying capacity is assumed to be equal to

$$P = 2A_f f_{crit}$$

where  $f_{crit}$  is determined as for a corresponding column of solid timber, but instead of the geometrical slenderness ratio of the column

$$\lambda = \ell \sqrt{\frac{2A_f}{I_t}}$$

the effective slenderness ratio

$$\lambda_e = \lambda \sqrt{1 + \mu}$$

is used, where  $\mu$  is determined as stated below:

Glued V-truss:

$$\mu = 4 \left(\frac{e}{i_f}\right)^2 \left(\frac{h}{\ell}\right)^2$$

$\lambda_e$  is not to be taken less than  $1.05 \lambda$ .

Glued N-truss:

$$\mu = \left(\frac{e}{i_f}\right)^2 \left(\frac{h}{\ell}\right)^2$$

$\lambda_e$  is not to be taken less than  $1.05 \lambda$ .

Nailed V-truss:

$$\mu = 25 \frac{hEA_f}{\ell^2 nk \sin 2\theta}$$

Nailed N-truss:

$$\mu = 50 \frac{hEA_f}{\ell^2 nk \sin 2\theta}$$

## 5. SHEAR FORCES

The column should be designed for a shear force  $Q$  given by

$$Q = \begin{cases} \frac{P}{60} \frac{f_c}{f_{crit}} & \text{for } 60 \leq \lambda_e \\ \frac{\lambda_e}{60} \frac{P}{60} \frac{f_c}{f_{crit}} & \text{for } 30 \leq \lambda_e < 60 \\ \frac{P}{120} \frac{f_c}{f_{crit}} & \text{for } \lambda_e < 30 \end{cases}$$

## 6. REFERENCES

K. Möhler, J. Ehlbeck, G. Hempel & P. Köster: Erläuterungen zu DIN 1052, Blatt 1 und 2 - Holzbauwerke - Ausgabe Oktober 1969 with further references.

The design of built-up timber columns. Aalborg University Centre, Pure and Applied Mechanics, Report R7406, 1974. (Prepared for CIB-W18).

No.

05

Subject:

TESTING OF TIMBER STRUCTURES

Draft No.

1

Date:

76.03.08

## 1. SCOPE

According to CIB Timber Code, section 3, the design of structures shall be based on reliable calculations or tests. This standard refers to load testing to determine the rigidity and strength of timber structures. It refers, in the first place, to structures consisting of timber and plywood, but may also with certain modifications be applied to structures of other wood-based materials and to structures where wood is combined with other materials.

Testing may refer to rigidity and strength, or to either of these properties separately, in which case only the appropriate sections of the standard are applicable.

## 2. NOTATIONS

- Q The applied test load.
- $Q_{max}$  The highest load by non-destructive tests.
- $Q_t$  The applied test load corresponding to the external characteristic load.
- $Q_u$  The ultimate load by destructive tests.
- $Q_1$  Initial load.
- t The time for the duration of  $Q_t$ .

## 3. DEFINITIONS

For the purpose of this standard the following distinction is made between proof and prototype testing:  
*Proof testing* is the application of test loads to a structure or element to ascertain the structural characteristics of only that one unit under test.

*Prototype testing* is the application of test loads to a structure or element to ascertain the structural characteristics of structures or elements which are nominally identical to the unit or units tested.

- : The purpose of prototype testing may be to provide a basis for type approval of special structures or of a special
- : design calculation for a group of structures. The standard may also be applicable for limited purposes where gene-
- : ral approval is not involved.

## 4. AUTHORITY

The authority entitled to give their approval of the structure(s) shall appoint a competent body for the selection of test specimens, and for the testing and the evaluation of the test results.

## 5. SPECIFICATION

The structure shall be specified in all respects which are relevant to its structural behaviour, to enable the supervisor to check that the selected test specimens properly represent the types of structure to which the test result will be applied.

- : All members must be specified in terms of their dimensions and grade as well as their location, normally by con-
- : struction drawings and material specification. In many cases a production specification is also required, e.g. for
- : glued structures the gluing method must be described. The intended function must be stated, for instance charac-
- : teristic load, deflection at permissible load, etc. For type approval a further specification is usually required con-
- : cerning factors such as production quality control procedures.

## 6. SELECTION OF SPECIMENS FOR PROTOTYPE TESTING

The tested specimens shall be representative of, and in no case superior to, what is declared in the type specification.

## 7. NUMBER OF TESTS FOR PROTOTYPE TESTING

For testing of a specified type of structure, a minimum of five specimens shall generally be supplied, of which at least four shall be tested. The spare specimen is intended for checking of the test method, etc. (see 8).

- : If the specification gives alternatives with regard to material grades and dimensions within the structure type,
- : then the minimum number shall in principle apply to each alternative. In such cases, however, the minimum
- : number may be decreased by agreement with the testing institute. If several combinations of load are to be
- : tested, the number of test specimens shall be increased correspondingly (cf. 9.1).

## 8. METHOD OF TESTING

The foundation, lateral support and load distribution (cf. 9.3) for the test shall be chosen to simulate actual service conditions. The test conditions must on no account be such as to lead to an overestimate of the structure's load-bearing capacity.

The deflection shall be measured at the point where maximum deflection may be expected, and also at any other points considered necessary for assessing the performance of the structure.

- : The technique for the testing should simulate as closely as possible the conditions expected in use. This includes
- : among other things the distribution of the load, and the main and lateral methods of support. Load and deflection
- : curves shall always be recorded, including those referring to maximum load tests, and also the shape of the curves
- : shall be reported in defining the ultimate load, including any discontinuities.

The errors of measurement - the total of systematic errors and the mean value of random errors - shall not exceed 3 per cent of the load and 2 per cent of the deflections.

## 9. PROGRAMME FOR LOADING AND DEFLECTION MEASUREMENT

### 9.1 Load combinations

Of the combinations of load expected in service, those decisive for the function and safety shall be tested.

- : The most severe load combination is used in the test. If there is doubt about which is the most severe load com-
- : bination for the structure, either due to functional requirements or because different components have been
- : designed for different loading patterns, it may be necessary to test two or more load conditions. If the tested
- : specimen has not been loaded to destruction or otherwise damaged by one load combination, then it may be
- : used for testing under another load combination.

### 9.2 Distribution of load

The test load  $Q$  shall be distributed as far as possible according to the actual distribution of the external design load and the structure's own weight. Important discrepancies must be compensated for by adjustments to the value of  $Q$ .

### 9.3 Loading levels

The levels of loading (see 9.4) relate to an applied load  $Q_t$  corresponding to the external characteristic load.

- : For prototype testing  $Q_t$  must be estimated on the basis of calculations or preliminary tests.

#### 9.4 Loading cycle

The testing starts at  $Q = 0$  (or at an initial load  $Q_1 < Q_t$ )

- 1) Increase the load to  $0.5 Q_t$
- 2) Release the load to  $Q = 0$  ( $Q = Q_1$ )
- 3) Increase the load to  $Q = Q_t$
- 4) Maintain the load  $Q = Q_t$  during the time  $t$
- 5) Load to destruction  $Q_u$

Alternatively:

- 5a) Increase the load to a certain value  $Q_{max}$
- 6) Release the load from  $Q_{max}$  to 0.

#### 9.5 Rate of loading

When applying the load continuously, the rate of loading shall not exceed  $Q_t/4$  per min. When loading in increments the size of the loading increments must not exceed  $Q_t/4$ , and the interval between two succeeding load increments shall be at least 1 min.

The time ( $t$ ) for the duration of load ( $Q_t$ ) shall be at least 24 h for one of the tested specimens, and at least 1 h for the other tested specimens.

#### 9.6 Measurement of deflection

Deflection shall be measured at least after each change of load of max.  $Q_t/4$ . During 24 h load maintenance ( $Q_t$ ) the deflection shall be measured at least three times in addition to the beginning and end of the period, preferably at equal intervals of the logarithm of time.

### 10. TEST CLIMATE

Testing shall normally be carried out in a climate which corresponds to that specified for the use of the structure.

- : The test results may be converted between moisture classes using the modification factors generally used for
- : working stresses and elasticity moduli.

### 11. REFERENCES

The background for this standard is »Nordiska riktlinjer för träkonstruktioner 3. NKB-paper, No. 18, December 1975». (Nordic Committee for Building Regulations).